

# Ha-VIS eCon 3000

## Full Gigabit Ethernet

### Basic PoE / PoE+



**5 to 7 Ethernet ports RJ45, SC/LC (SFP) and PoE / PoE+**  
 Unmanaged Plug & Play Ethernet switches for DIN rail assembly in control cabinets  
 Commercial Temp.: 0 °C ... +55 °C / Industrial Temp.: -40 °C ... +70 °C



- Energy supply of up to 4 terminal devices via PoE+ (137 watts) acc. to IEEE 802.3at
- Full gigabit Ethernet, non-blocking switch architecture acc. to IEEE 802.3
- Support of jumbo frames
- Variants with industrial temperature range of -40°C ... +70 °C
- Surge protection and reverse polarity protection
- Minimum energy consumption due to Energy-Efficient Ethernet
- Optimised DIN rail bracket

**Target markets**

Machinery & Robotics	Automation technology	Industrial network infrastructures
Wind Energy Solar Energy	Transportation	Shipbuilding



### General description

The Ha-VIS eCon 3000 Full Gigabit family of unmanaged Ethernet switches is equipped with up to 7 gigabit Ethernet ports and allow for cost-efficient and quick expansion and/or reconstruction of network infrastructures with high bandwidth requirements. In this, all switches support extra-long Ethernet frames (jumbo frames). The switches work as power sourcing equipment (PSE) and are capable of simultaneously providing the full PoE output of 34.2 watts on up to four ports. The slender design of the switches

enables an extremely high packing density on the DIN rail. Various combinations of variants with RJ45, fibre optic cables and SFP ports are available. Automatic detection of the transmission rate (auto-negotiation) and of the wiring of the twisted pair data cable (autopolarity and auto-MDI(X)) allow for simple plug & play. All variants are available with the temperature ranges „Industrial“ and „Commercial“.

### Technical characteristics

**Switch Features**

Enclosures width	25 mm	
Number of ports	5, 6, 7	
Switching technology	Store and Forward	
Supported standards	IEEE 802.3	
Frame Size	10 kbytes	
MAC table size	8k entries	
Packet buffer size	1 Mbit	
Non-blocking	Yes	
Quality of service	Yes	
Energy-Efficient Ethernet	Yes	
PROFINET compatible	Yes	
EthernetIP compatible	Yes	

**Voltage supply**

Nominal voltage	48 VDC $\equiv$	54 VDC $\equiv$
Permissible voltage range	44 VDC ... 57 VDC $\equiv$	50 VDC ... 57 VDC $\equiv$
Surge protection	Yes	
Reverse polarity proof	Yes	
Starting current	6.40 A	7.20 A
Overcurrent protection at input	Yes (12 A)	
Max. power consumption without PoE	3,84 W ... 4,56 W	
Cross-section / Wire gauge	0.08 mm <sup>2</sup> ... 2.5 mm <sup>2</sup> (28 AWG ... 12 AWG)	
Connection type	3-pole, pluggable screwed contact	
Pinout	+ / - / $\oplus$	
Supply circuit (acc. to 60950)	SELV (circuit breaker 10 A)	

**Ethernet Ports 10BASE-T<sub>e</sub> / 100BASE-TX EEE / 1000BASE-T EEE**

Connection type	RJ45
Auto-negotiation	Yes
Auto-polarity	Yes
Auto-MDI(X)	Yes
Transfer conditions	Twisted Pair
Transfer speed	10 / 100 / 1000 Mbit/s
Transfer length	100 m (twisted pair, Cat 5)

**Ethernet Ports 1000BASE-SX / 1000BASE-LX**

Type of fibre	Multimode (MM)	Singlemode (SM)
Connection type	SC Duplex	
Transfer conditions	FO	
Wavelength	850 nm	1310 nm
Transfer speed	1000 Mbit/s	
Transfer length	0.55 km	10 km
Output power	-9.5 dBm ... -3 dBm	-9.5 dBm ... -4 dBm
Input sensitivity	≤ -17 dBm	≤ -21 dBm

**SFP ports**

Transfer standard	Depending on used SFP
Connection type	Depending on used SFP, RJ45 or LC
Transfer conditions	Depending on used SFP, TP or FO
Transfer speed	Depending on used SFP, 100 or 1000 Mbit/s
Transfer length	Depending on used SFP



**HARTING Technology Group**  
 P.O.Box 1473, D-32325 Espelkamp  
 Wilhelm-Harting-Straße 1, D-32325 Espelkamp, Germany

ICPN-Service@harting.com | Service hotline: +49 5772 47-9479  
 Fax: +49 5772 47-495 | www.HARTING.com/de/ethernet-switches

**Note:** We reserve the right to make technical changes to the products and to the content of this document at any time without prior notification. The HARTING Technologiegruppe does not accept any responsibility for possible errors or incompleteness in this document. We reserve all the rights to this document and the topics and illustrations contained within it. Copying, disclosure to third parties or use of its content - even partially - is forbidden without the prior written consent of the HARTING Technologiegruppe.

PoE	PoE	PoE+
Number of PoE ports	4	
Standard	IEEE 802.3af / IEEE 802.3at	
PoE type	PSE	
Supported mode	Alternative A	
Supply voltage PSE	48 VDC $\equiv$	54 VDC $\equiv$
Max. current consumption PSE	1380 mA	2380 mA
Max. current	375 mA	638 mA
Maximum output power PSE	15.4 W per port 61.6 W total	34.2 W per port 136.8 W total
Supported cabling	See 802.3at, section 33.1.4	
PoE pinout	Alternative A, MDI-X (1/2 = V-, 3/6 = V+)	

#### Status and diagnostic displays

Power („Pwr“) $\phi$ lights up green	Supply voltage is applied
Link/Activity („L/A“) off	No link
Link/Activity („L/A“) lights up green	Link is active
Link/Activity („L/A“) flashes green	Link is active and data is transferred
Link speed („Spd“) off	10 Mbit/s
Link speed („Spd“) lights up yellow	100 Mbit/s
Link speed („Spd“) lights up green	1000 Mbit/s
PoE status $\phi$ off	PoE is inactive / low voltage
PoE status $\phi$ lights up green	Voltage in PoE range
PoE status $\phi$ lights up blue	Voltage in PoE+ range
PoE status $\phi$ lights up red	Error

#### Enclosures

Enclosures width	25 mm
Dimensions H x W x D (without pluggable screw contact and holding bracket)	142 mm x 25 mm x 107.5 mm
Weight	498 g ... 531 g
Type of installation	35 mm DIN rail acc. to EN 60 715
Material enclosures	Anodised aluminium / Powder-coated steel sheet
Protection degree (with plugged screw contact)	IP30
Protection class	III

#### Ambient conditions

Commercial temperature range	0 °C ... +55 °C
Industrial temperature range	-40 °C ... +70 °C
Storage temperature range	-40 °C ... +85 °C
Relative humidity (operation)	0 % ... 95 % (not-condensing)
Relative humidity (storage and transport)	0 % ... 95 % (not-condensing)
Air pressure (operation)	2000 m (795 hPa)

#### Approvals

CE, FCC CFR 47 Part 15, cUL US 508 listed, DNV GL, LR, NK, ABB IIT

#### EMC and environmental conditions

##### EMC Interference immunity (EN 61000-6-1, 61 000-6-2 55024)

Electrostatic discharge (ESD) EN 61 000-4-2  
Electromagnetic field EN 61 000-4-3  
Rapid transients (burst) EN 61 000-4-4  
Surge voltages EN 61 000-4-5  
Conducted interference voltages EN 61 000-4-6

##### EMC Interference emission (EN 61000-6-4, EN 55 032, FCC CFR 47 Part 15)

##### Mechanical stability (EN 60721-3)

IEC 60068-2-6 Vibration  
IEC 60068-2-6 Vibration resonance search  
IEC 60068-2-27 Shock test

#### Included in delivery

- Pluggable screw contact for voltage supply
- Assembly instruction

#### Drawings

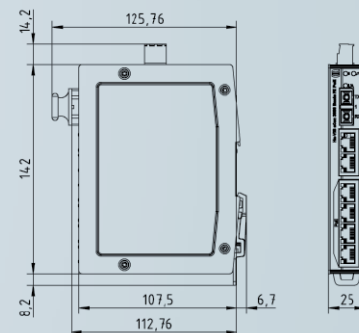

## Technical characteristics / order information

#### Ports / order information

RJ45	SFP	SC	Enclosures width	Current consumption @ 54 VDC with PoE	MTBF in Mio. h	Commercial Temp.: 0 °C ... +55 °C		Industrial Temp.: -40 °C ... +70 °C	
						Switch	Part no.	Switch	Part no.
4	-	1x MM (0.55 km)	25 mm	2.42 A	1.13	Ha-VIS eCon 3041GB-AD-P	24 03 404 1130	Ha-VIS eCon 3041GBT-AD-P	24 03 404 1120
4	-	1x SM (10 km)	25 mm	2.42 A	1.13	Ha-VIS eCon 3041GB-AF-P	24 03 404 1230	Ha-VIS eCon 3041GBT-AF-P	24 03 404 1220
4	-	2x MM (0.55 km)	25 mm	2.44 A	1.11	Ha-VIS eCon 3042GB-AD-P	24 03 404 2130	Ha-VIS eCon 3042GBT-AD-P	24 03 404 2120
4	-	2x SM (10 km)	25 mm	2.44 A	1.11	Ha-VIS eCon 3042GB-AF-P	24 03 404 2230	Ha-VIS eCon 3042GBT-AF-P	24 03 404 2220
4	3	-	25 mm	2.44 A	0.70	Ha-VIS eCon 3043GB-AC-P	24 03 404 3330	Ha-VIS eCon 3043GBT-AC-P	24 03 404 3320
5	-	-	25 mm	2.42 A	1.08	Ha-VIS eCon 3050GB-A-P	24 03 405 0030	Ha-VIS eCon 3050GBT-A-P	24 03 405 0020
5	-	1x MM (0.55 km)	25 mm	2.44 A	1.06	Ha-VIS eCon 3051GB-AD-P	24 03 405 1130	Ha-VIS eCon 3051GBT-AD-P	24 03 405 1120
5	-	1x SM (10 km)	25 mm	2.44 A	1.06	Ha-VIS eCon 3051GB-AF-P	24 03 405 1230	Ha-VIS eCon 3051GBT-AF-P	24 03 405 1220
5	2	-	25 mm	2.45 A	0.68	Ha-VIS eCon 3052GB-AC-P	24 03 405 2330	Ha-VIS eCon 3052GBT-AC-P	24 03 405 2320
6	-	-	25 mm	2.43 A	1.01	Ha-VIS eCon 3060GB-A-P	24 03 406 0030	Ha-VIS eCon 3060GBT-A-P	24 03 406 0020
6	1	-	25 mm	2.45 A	0.66	Ha-VIS eCon 3061GB-AC-P	24 03 406 1330	Ha-VIS eCon 3061GBT-AC-P	24 03 406 1320
7	-	-	25 mm	2.45 A	0.63	Ha-VIS eCon 3070GB-A-P	24 03 407 0030	Ha-VIS eCon 3070GBT-A-P	24 03 407 0020