

THIS DRAWING IS UNPUBLISHED. RELEASED FOR PUBLICATION 20
 © COPYRIGHT 20 BY - ALL RIGHTS RESERVED.

REVISIONS					
P	LTR	DESCRIPTION	DATE	DWN	APVD
	A	RELEASED	13DEC2017	RI	EI
	A1	REVISED PER ECR-18-004154	04APR2018	RI	EI
	A2	REVISED PER ECR-18-009643	21JUN2018	TS	EI
	A3	REVISED PER ECR-19-005449	22APR2019	DW	CW

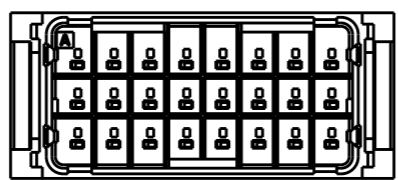
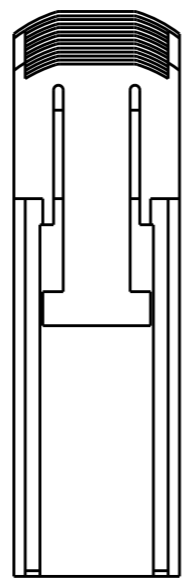
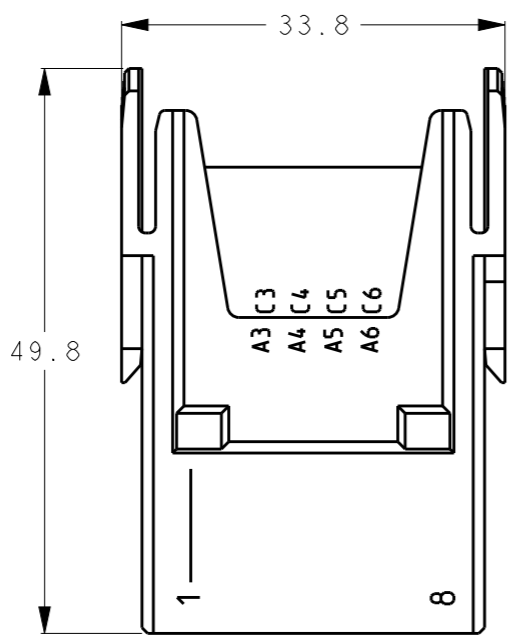
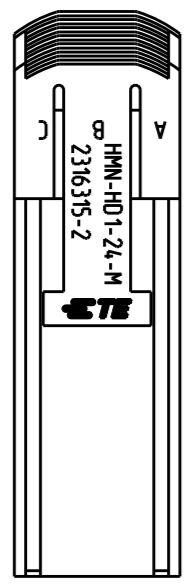
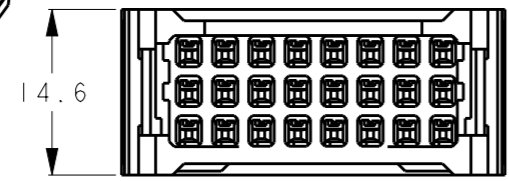
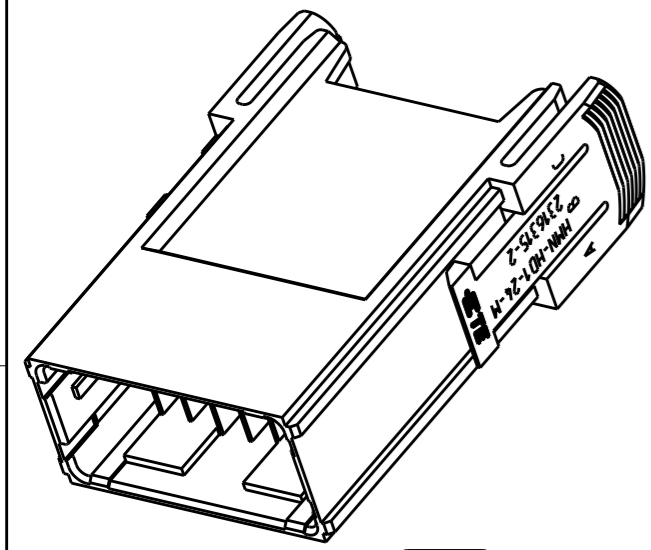

- TECHNICAL CHARACTERISTICS :
 INSULATION MATERIAL : PBT
 RATED VOLTAGE : 300V
 RATED CURRENT : 3.7A
 INSULATION RESISTANCE : >=100MΩ
 RATED IMPULSE VOLTAGE : 4KV
 POLLUTION DEGREE : 3
 FLAMMABILITY : UL94V-0
 MATING CYCLES : SEE TABLE 1
 OPERATION TEMPERATURE : -40°C~+125°C
 WIRE RANGE : 0.05 SQmm~0.87 SQmm
 CONTACT TYPE : CRIMP CONTACT
- CONTACT NEED TO BE ORDERED SEPARATELY.
 (ORDER No. REFER TO DRAWING : SEE TABLE 1)
- FRAMES NEED TO BE ORDERED SEPARATELY.
 (ORDER No. REFER TO DRAWING : SEE TABLE 2)

TABLE 1

MATING CYCLES	INSULATION RANGE	WIRE RANGE	SIZE	PART NUMBER		DESCRIPTION
				REEL	L/P	
500	1.4-2.2	AWG22-18, 0.34-0.87SQmm	2L	1-2316663-4	-	HDI TAB CONTACT
	1.4-2.2	AWG22-18, 0.34-0.87SQmm	2L	2316663-4	2316669-4	
	1.08-1.9	AWG28-22, 0.08-0.37SQmm	L	2316663-3	2316669-3	
	1.08-1.6	AWG28-22, 0.08-0.37SQmm	M	2316663-2	2316669-2	
	0.6-1.2	AWG30-28, 0.05-0.10SQmm	S	2316663-1	2316669-1	

TABLE 2

DESCRIPTION	PART NUMBER
H24B MALE FRAME FOR 6 MODULES	T2070244101-002
H16B MALE FRAME FOR 4 MODULES	T2070164101-002
H10B MALE FRAME FOR 3 MODULES	T2070104101-002
H6B MALE FRAME FOR 2 MODULES	T2070064101-002
H10A MALE FRAME FOR 1 MODULE	T2079104101-002

2316315-2
PART NUMBER

THIS DRAWING IS A CONTROLLED DOCUMENT.		DWN R. ITO 13DEC2017	TE Connectivity		
DIMENSIONS: mm		CHK T. SHIMOYASU 13DEC2017			
TOLERANCES UNLESS OTHERWISE SPECIFIED:		APVD F. IKEMATSU 13DEC2017	NAME MODULE INSERT, HMN-HDI-24-M HDC DYNAMIC		
0 PLC ±0.5 1 PLC ±0.5 2 PLC ±0.5 3 PLC ±0.5 4 PLC ±0.5 ANGLES ±5°		PRODUCT SPEC 108-140157	RESTRICTED TO		
MATERIAL SEE NOTE		FINISH -	APPLICATION SPEC 114-78025	SIZE A3	CAGE CODE -
		WEIGHT 12.9g	DRAWING NO C-2316315	SCALE 3:2	
		CUSTOMER DRAWING	SHEET 1 OF 1	REV A3	