

General Description

The AP3422 contains two independent 1.1MHz fixed frequency, current mode, PWM synchronous buck (step-down) DC-DC converters, each of them is capable of driving a 800mA load with high efficiency, excellent line and load regulation. Each converter integrates a main switch and a synchronous switch without an external Schottky diode. It is ideal for powering portable equipment that runs from a single Li-ion battery.

A standard series of inductors are available from several different manufacturers optimized for use with the AP3422. This feature greatly simplifies the design of switch-mode power supplies.

This IC is available in DFN-3×3-10 package.

Features

- High Efficiency: up to 95%
- Output Current on Each Channel: 800mA
- Input Voltage Range: 2.5V to 5.5V
- Fixed 1.1MHz Frequency
- 100% Duty Cycle in Dropout
- Built-in Short Circuit Protection
- Built-in Thermal Shutdown Function
- Built-in Current Limit Function
- Shutdown Current: <1 μ A

Applications

- GPS
- WiFi Card
- Portable Media Player
- Digital Still and Video Cameras

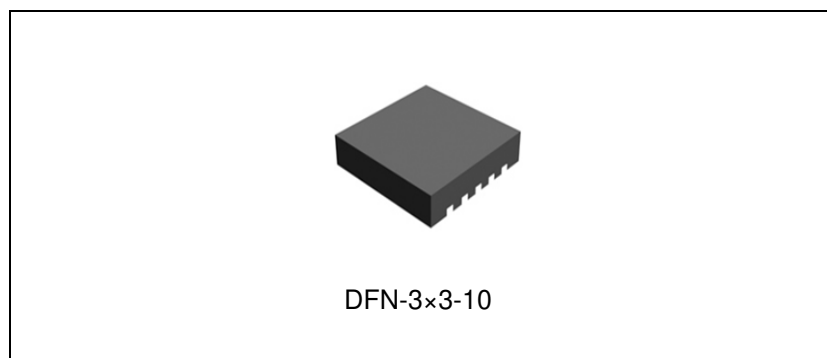

Figure 1. Package Type of AP3422

Pin Configuration

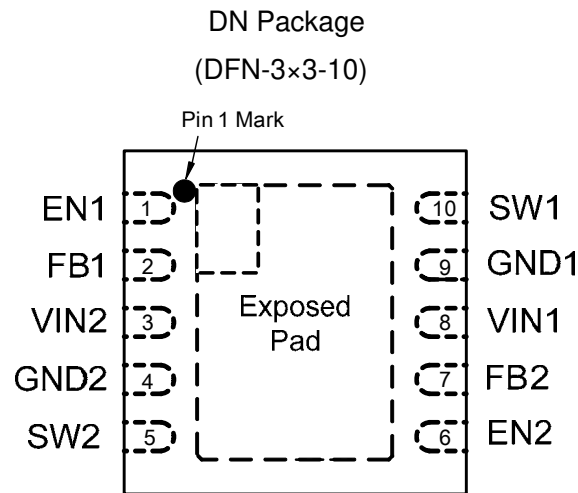

Figure 2. Pin Configuration of AP3422 (Top View)

Pin Description

Pin Number	Pin Name	Function
1	EN1	Channel 1 enable control input. Drive EN1 above 1.5V to turn on the Channel 1. Drive EN1 below 0.6V to turn it off (shutdown current < 0.1μA)
2	FB1	Channel 1 feedback input. Connect FB1 to the center point of the external resistor divider. The feedback voltage is 0.6V
3	VIN2	Channel 2 supply input. Bypass to GND with a 10μF or greater ceramic capacitor
4	GND2	Ground 2
5	SW2	Channel 2 power switch output. Inductor connection to drains of the internal PFET and NFET switches
6	EN2	Channel 2 Enable Control Input. Drive EN2 above 1.5V to turn on the Channel 2. Drive EN2 below 0.6V to turn it off (shutdown current < 0.1μA)
7	FB2	Channel 2 feedback input. Connect FB2 to the center point of the external resistor divider. The feedback voltage is 0.6V
8	VIN1	Channel 1 supply input. Bypass to GND with a 10μF or greater ceramic capacitor
9	GND1	Ground 1
10	SW1	Channel 1 power switch output. Inductor connection to drains of the internal PFET and NFET switches

Functional Block Diagram

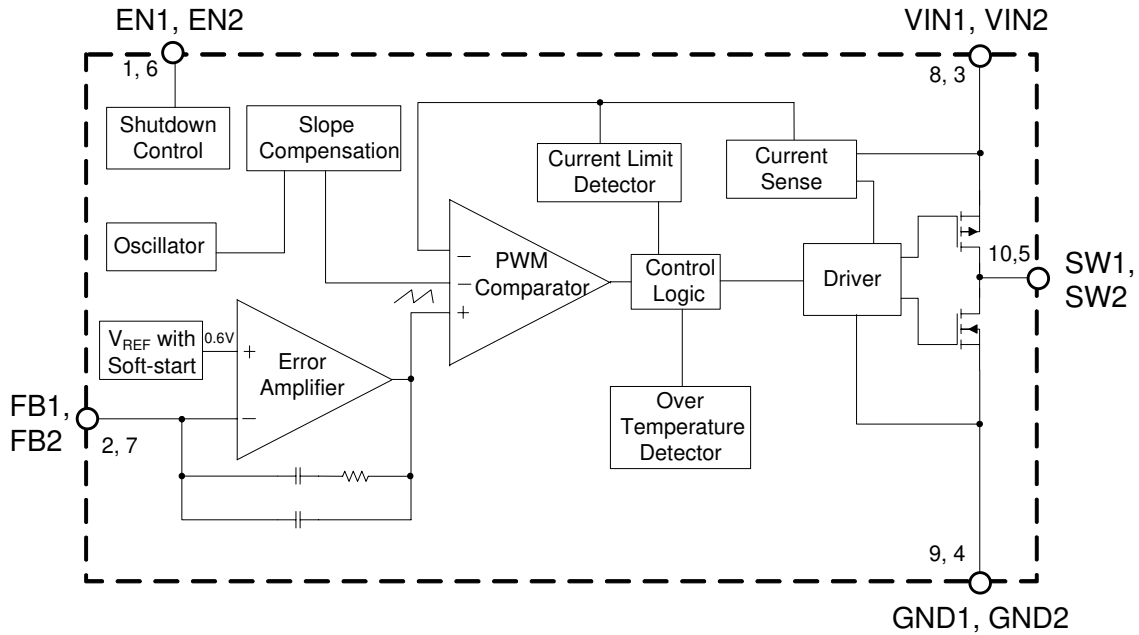
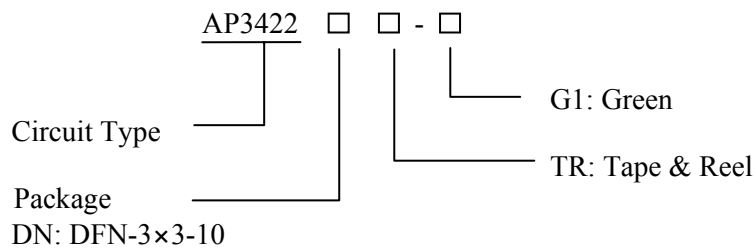

Figure 3. Functional Block Diagram of AP3422 (Diagram represents 1/2 of the AP3422)

Ordering Information



Package	Temperature Range	Part Number	Marking ID	Packing Type
DFN-3×3-10	-40 to 85 °C	AP3422DNTR-G1	BDC	Tape & Reel

BCD Semiconductor's Pb-free products, as designated with "G1" suffix in the part number, are RoHS compliant and green.

**Dual 1.1MHz, 800mA Synchronous DC-DC Buck Converter****AP3422****Absolute Maximum Ratings (Note 1)**

Parameter	Symbol	Value	Unit
Input Voltage	V_{IN1}, V_{IN2}	-0.3 to 6	V
Feedback Voltage	V_{FB1}, V_{FB2}	-0.3 to $V_{IN} + 0.3$	V
EN1, EN2 Pin Voltage	V_{EN1}, V_{EN2}	-0.3 to $V_{IN} + 0.3$	V
SW1, SW2 Pin Voltage	V_{SW1}, V_{SW2}	-0.3 to $V_{IN} + 0.3$	V
Thermal Resistance	θ_{JA}	50	°C/W
Operating Junction Temperature	T_J	150	°C
Storage Temperature	T_{STG}	-65 to 150	°C
Lead Temperature (Soldering, 10sec)	T_{LEAD}	260	°C

Note 1: Stresses greater than those listed under “Absolute Maximum Ratings” may cause permanent damage to the device. These are stress ratings only, and functional operation of the device at these or any other conditions beyond those indicated under “Recommended Operating Conditions” is not implied. Exposure to “Absolute Maximum Ratings” for extended periods may affect device reliability.

Recommended Operating Conditions

Parameter	Symbol	Min	Max	Unit
Input Voltage	V_{IN1}, V_{IN2}	2.5	5.5	V
Maximum Output Current	$I_{OUT1 (MAX)},$ $I_{OUT2 (MAX)}$	800		mA
Operating Ambient Temperature	T_A	-40	85	°C



Dual 1.1MHz, 800mA Synchronous DC-DC Buck Converter

AP3422

Electrical Characteristics

$V_{IN1}=V_{IN2}=V_{EN1}=V_{EN2}=3.6V$, $T_A=25^\circ C$, unless otherwise specified. Specifications with **boldface type** apply over full operating temperature range from -40 to $85^\circ C$.

Parameters	Symbol	Conditions	Min	Typ	Max	Unit
Supply Current on Each Converter	I_{CC}	$V_{FB}=0.55V$		400	600	μA
Shutdown Supply Current on Each Converter	I_{SHDN}	$V_{EN}=0V, V_{IN}=5.5V$		0.01	1	μA
Under Voltage Lockout Threshold	V_{UVLO}	Rising Edge		2.27		V
Under Voltage Lockout Hysteresis	V_{HUVLO}			200		mV
Feedback Bias Current	I_{FB}	$V_{FB}=0.65V$	-50	0.5	50	nA
Feedback Voltage	V_{FB}	$I_{OUT}=100mA$	0.588/ 0.582	0.600	0.612/ 0.618	V
Maximum Output Current	$I_{OUT(MAX)}$	$V_{IN}=2.5V,$ $V_{OUT}=0.9V$	800			mA
		$V_{IN}=3.6V,$ $V_{OUT}=1.2V$	800			
		$V_{IN}=4.6V,$ $V_{OUT}=3.3V$	800			
Switch Current Limit	I_{LIM}	$V_{FB}=0.55V$	0.95	1.25		A
Oscillator Frequency	f_{OSC}		0.8	1.1	1.4	MHz
EN Pin Threshold	V_{ENL}				0.6	V
	V_{ENH}		1.5			
EN Pin Input Leakage Current	I_H	$V_{EN}=3.6V$	-0.1		0.1	μA
	I_L	$V_{EN}=0V$	-0.1		0.1	μA
Internal PFET On Resistance	R_{DSONP}	$I_{SW}=100mA$		0.44		Ω
Internal NFET On Resistance	R_{DSONN}	$I_{SW}=-100mA$		0.29		Ω
Maximum Duty Cycle	D_{MAX}	$V_{FB}=0.55V$		100		%
Soft-start Time	T_{SS}	$V_{EN}=0V$ to V_{IN} $I_{OUT}=50mA$		220		μs
Thermal Shutdown Threshold	T_{OTSD}			160		$^\circ C$
Thermal Shutdown Hysteresis	T_{HYS}			30		$^\circ C$



Typical Performance Characteristics

$L1=L2=10\mu\text{H}$, $C_{IN1}=C_{IN2}=C_{OUT1}=C_{OUT2}=10\mu\text{F}$, $T_A=25^\circ\text{C}$, unless otherwise noted.

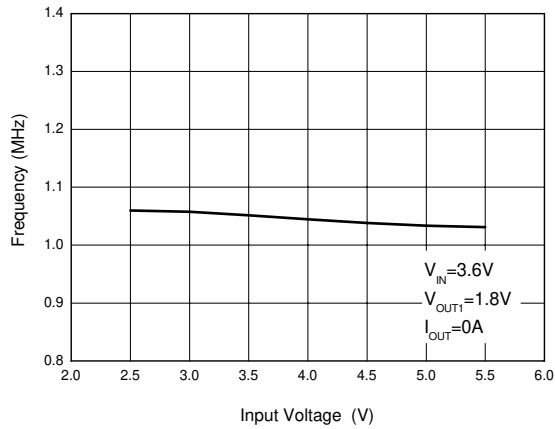

Figure 4. Frequency vs. Input Voltage

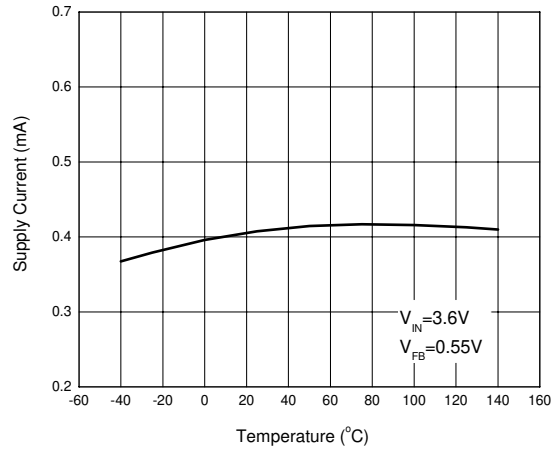

Figure 5. Supply Current vs. Temperature

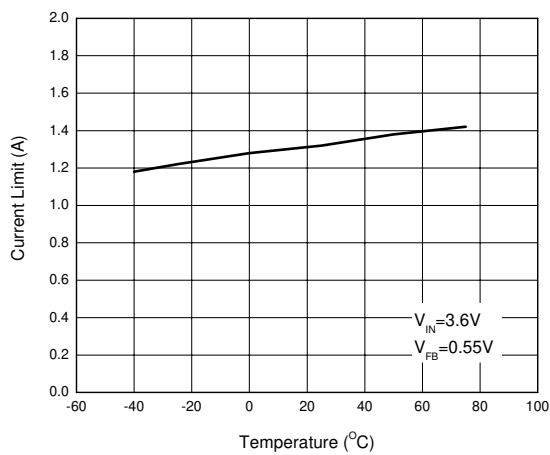

Figure 6. Current Limit vs. Temperature

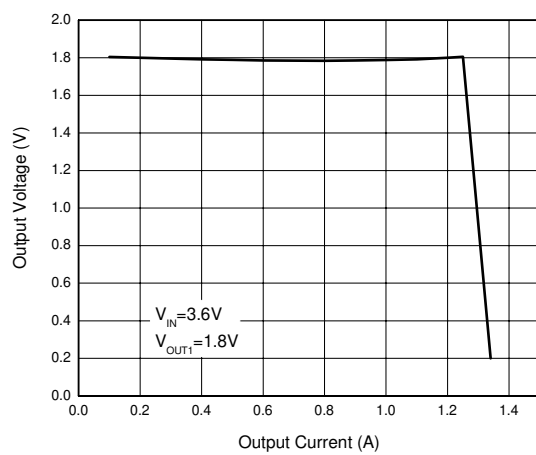

Figure 7. Output Voltage vs. Output Current

Typical Performance Characteristics (Continued)

$L_1=L_2=10\mu\text{H}$, $C_{IN1}=C_{IN2}=C_{OUT1}=C_{OUT2}=10\mu\text{F}$, $T_A=25\text{ }^\circ\text{C}$, unless otherwise noted.

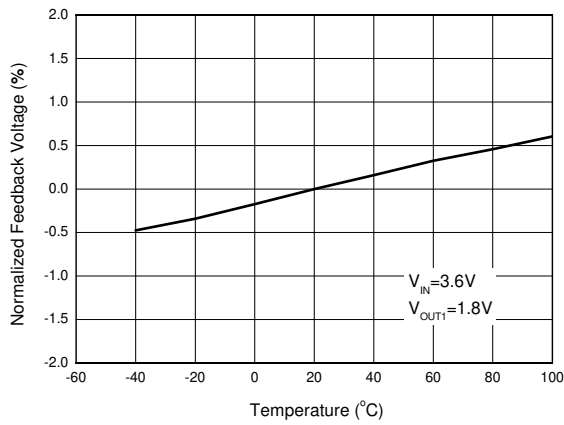

Figure 8. Normalized Feedback Voltage vs. Temperature

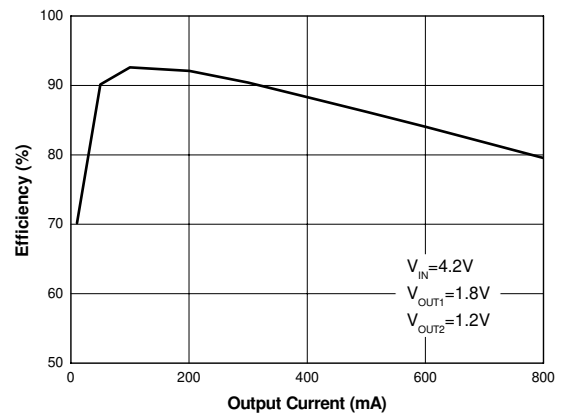
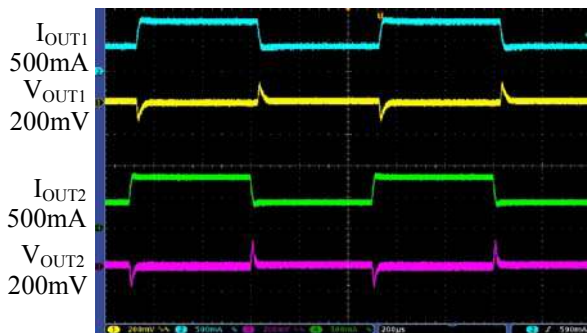
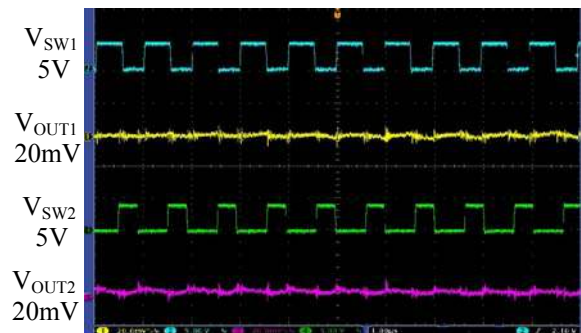

Figure 9. Efficiency vs. Output Current



Time 200μs/div

Figure 10. Load Transient ($V_{IN}=4.2\text{V}$, $V_{OUT1}=1.8\text{V}$, $V_{OUT2}=1.2\text{V}$, $I_{OUT1}=400\text{mA}$ to 800mA , $I_{OUT2}=400$ to 800mA)



Time 1μs/div

Figure 11. Heavy Load Operation ($V_{IN}=4.2\text{V}$, $V_{OUT1}=1.8\text{V}$, $V_{OUT2}=1.2\text{V}$, $I_{OUT1}=I_{OUT2}=800\text{mA}$)

Typical Performance Characteristics (Continued)

$L_1=L_2=10\mu\text{H}$, $C_{IN1}=C_{IN2}=C_{OUT1}=C_{OUT2}=10\mu\text{F}$, $T_A=25\text{ }^\circ\text{C}$, unless otherwise noted.

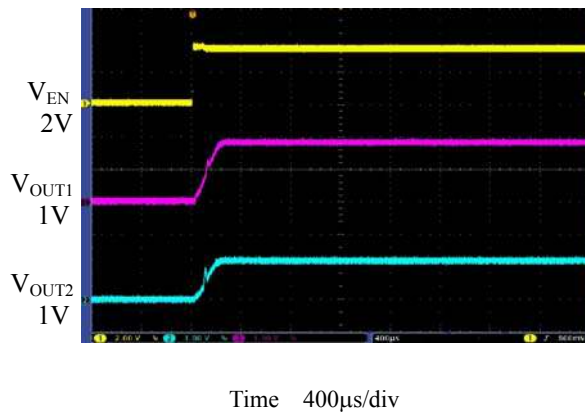

Figure 12. Start-up from Shutdown ($V_{IN}=4.2\text{V}$, $V_{OUT1}=1.8\text{V}$, $V_{OUT2}=1.2\text{V}$, $V_{EN}=0$ to 3.6V , $I_{OUT1}=I_{OUT2}=400\text{mA}$)

Typical Application

Figure 13. Typical Application of AP3422



Dual 1.1MHz, 800mA Synchronous DC-DC Buck Converter

AP3422

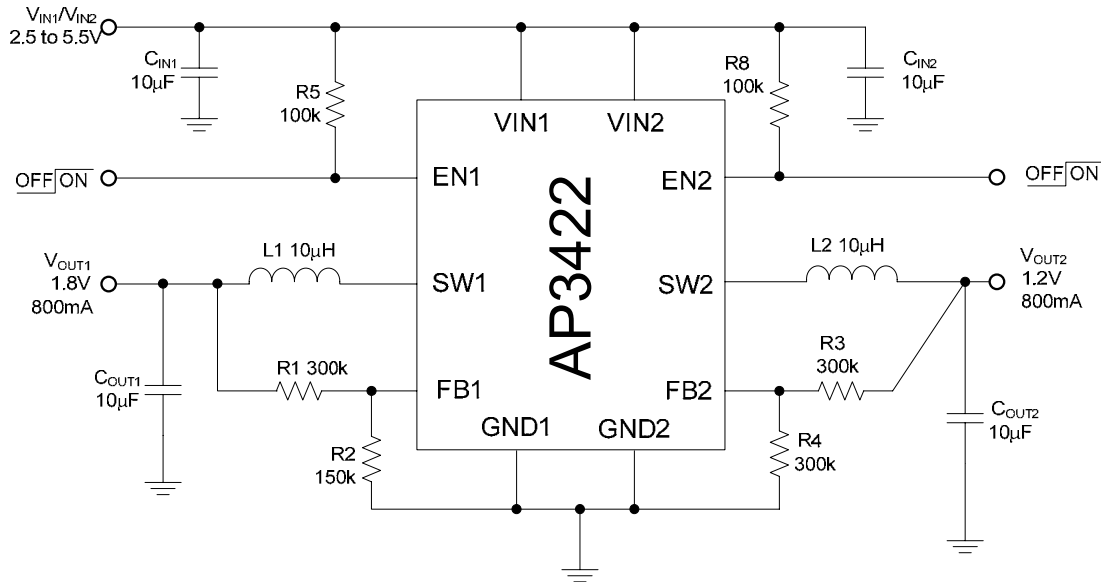
Mechanical Dimensions

DFN-3x3-10

Unit:mm(inch)

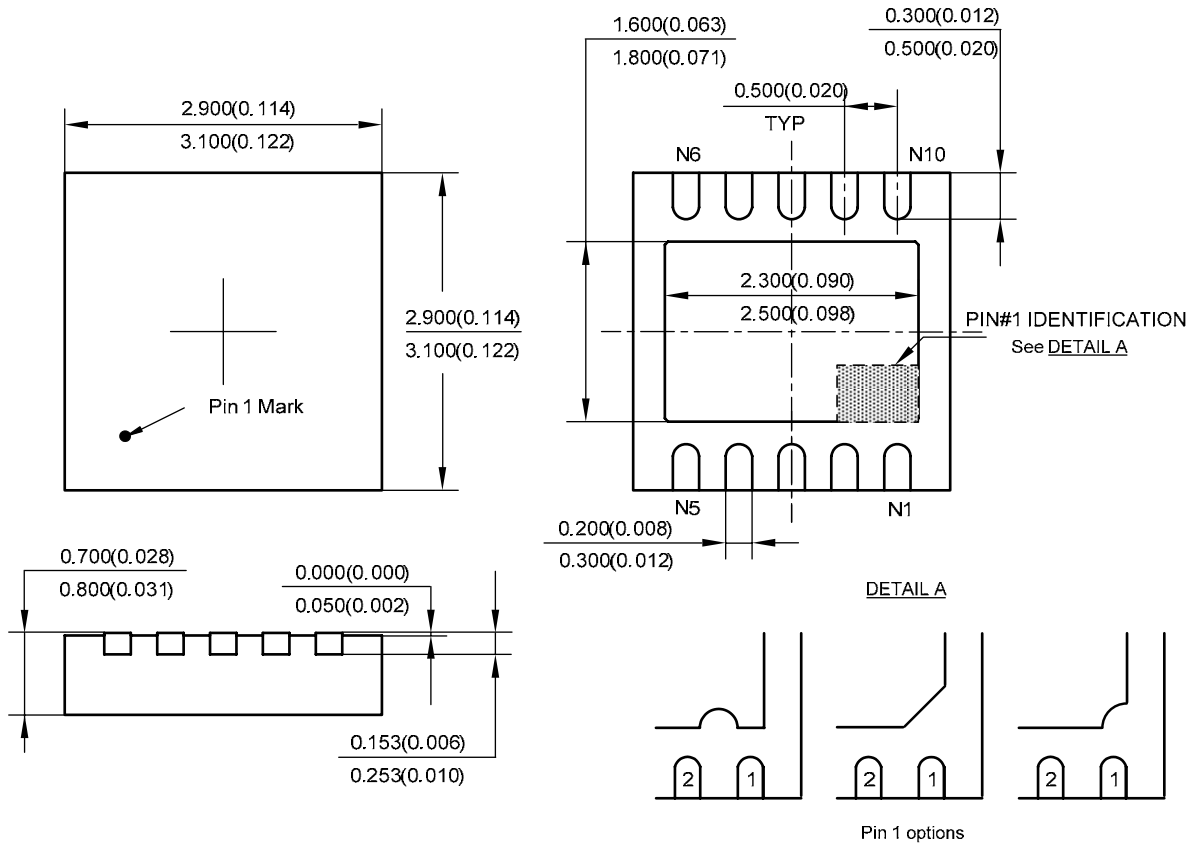



BCD Semiconductor Manufacturing Limited

<http://www.bcdsemi.com>

IMPORTANT NOTICE

BCD Semiconductor Manufacturing Limited reserves the right to make changes without further notice to any products or specifications herein. BCD Semiconductor Manufacturing Limited does not assume any responsibility for use of any its products for any particular purpose, nor does BCD Semiconductor Manufacturing Limited assume any liability arising out of the application or use of any its products or circuits. BCD Semiconductor Manufacturing Limited does not convey any license under its patent rights or other rights nor the rights of others.

MAIN SITE

- Headquarters

BCD Semiconductor Manufacturing Limited

No. 1600, Zi Xing Road, Shanghai Zizhu Science-based Industrial Park, 200241, China
Tel: +86-21-24162266, Fax: +86-21-24162277

- Wafer Fab

Shanghai SIM-BCD Semiconductor Manufacturing Co., Ltd.

800 Yi Shan Road, Shanghai 200233, China
Tel: +86-21-6485 1491, Fax: +86-21-5450 0008

REGIONAL SALES OFFICE

Shenzhen Office

Shanghai SIM-BCD Semiconductor Manufacturing Co., Ltd., Shenzhen Office

Unit A Room 1203, Skyworth Bldg., Gaoxin Ave. 1.S., Nanshan District, Shenzhen, China
Tel: +86-755-8826 7951
Fax: +86-755-8826 7865

Taiwan Office

BCD Semiconductor (Taiwan) Company Limited

4F, 298-1, Rui Guang Road, Nei-Hu District, Taipei, Taiwan
Tel: +886-2-2656 2808
Fax: +886-2-2656 2806

USA Office

BCD Semiconductor Corp.

30920 Huntwood Ave. Hayward, CA 94544, USA
Tel : +1-510-324-2988
Fax: +1-510-324-2788