

LOC	DIST	REVISIONS					
		P	LTR	DESCRIPTION	DATE	DWN	APVD
HK	00	0		RELEASED	15FEB2001	EL	SR
		B		EC OK40 0007 05	07JAN2005	EL	SR

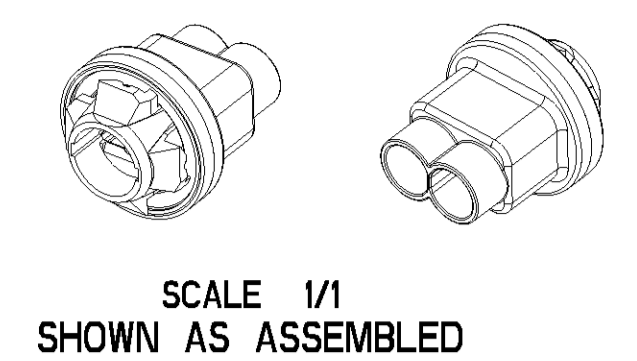
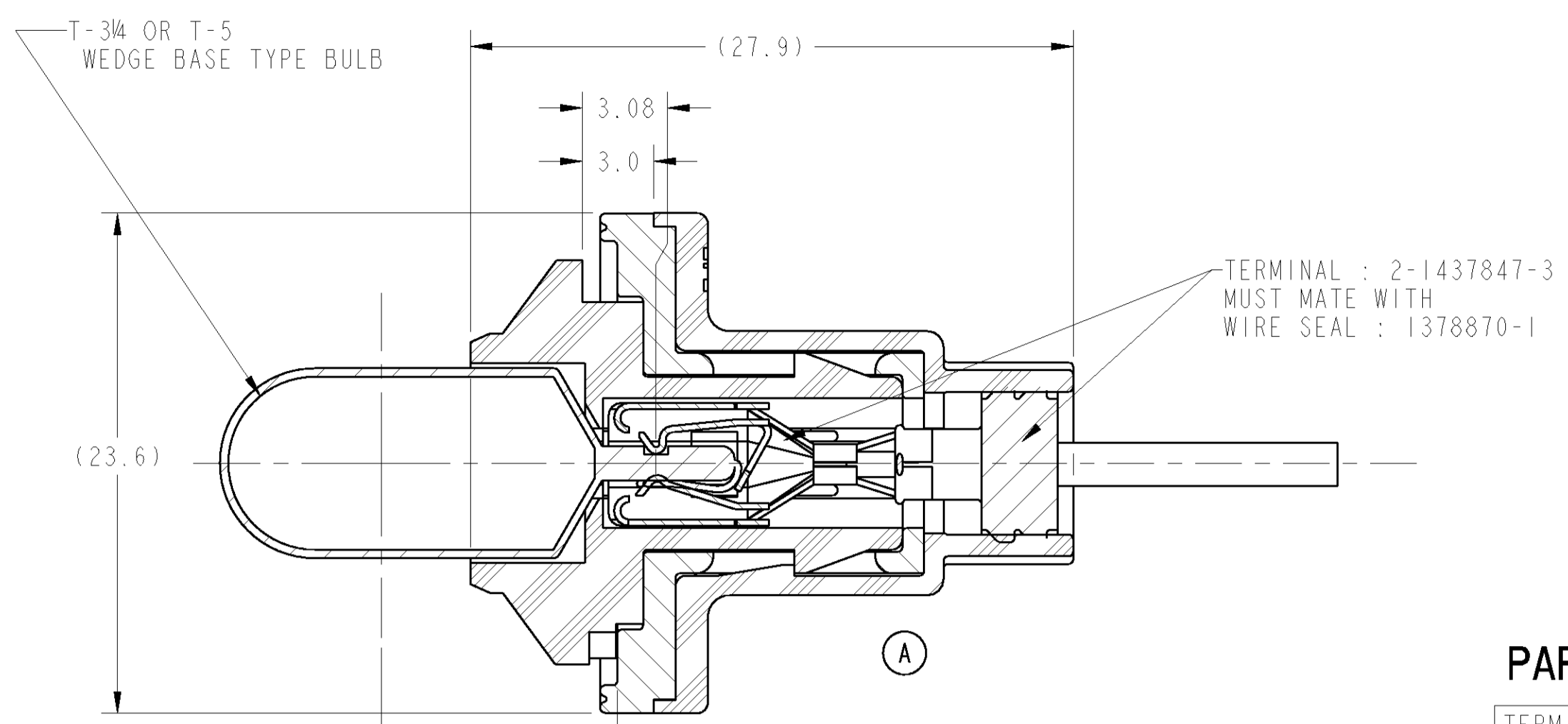
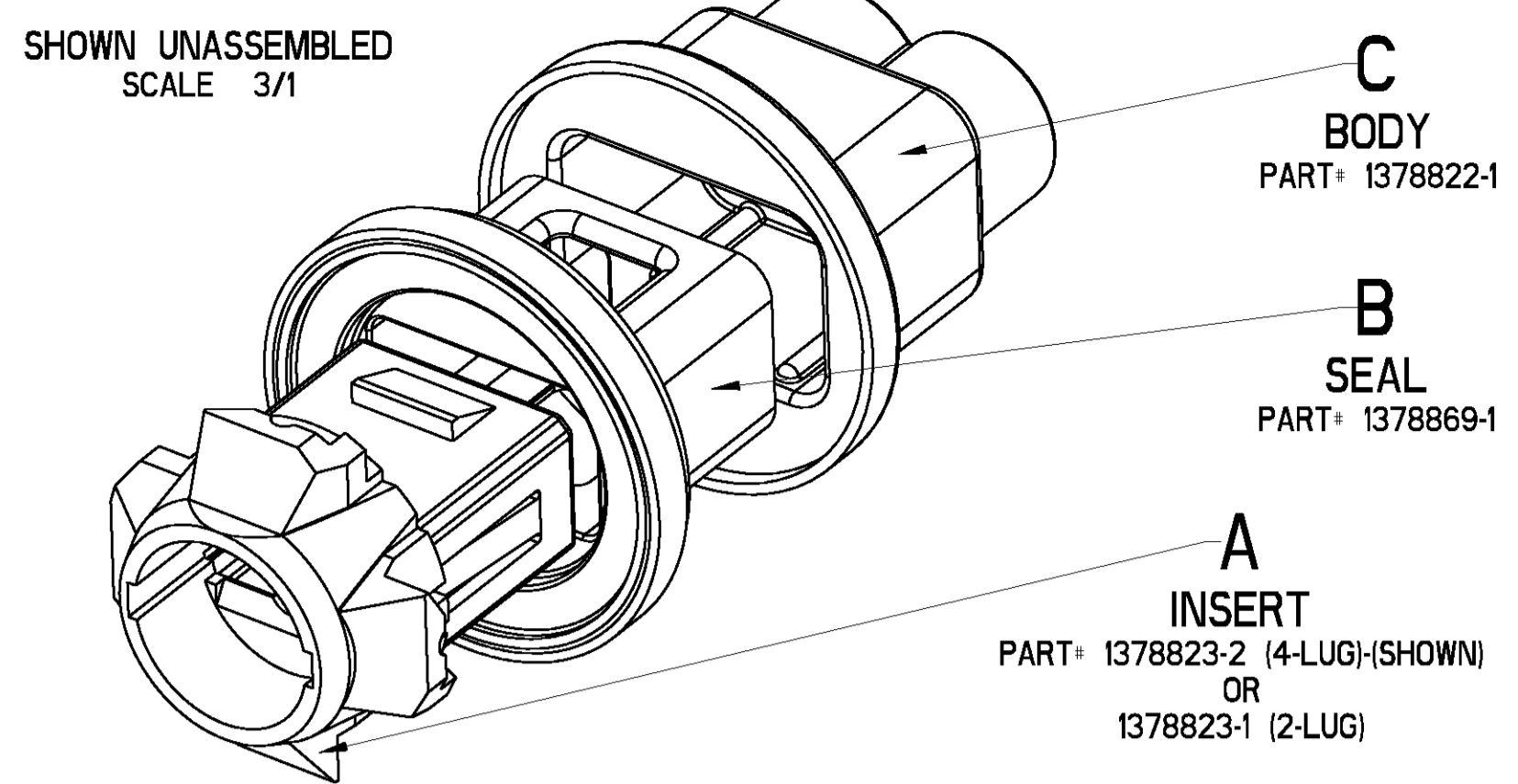

SCALE 3/1

SOCKET ASSEMBLY NUMBER	ITEM	A INSERT	B SEAL	C BODY
4-1454396-7	4-LUG	1378823-2	1378869-1	1378822-1
9-1454396-3	2-LUG	1378823-1	1378869-1	1378822-1

**PARTS TO BE TESTED TO THE FOLLOWING:**

TERMINAL INSERTION	15N MAXIMUM
TERMINAL RETENTION	90N MINIMUM
BULB INSERTION	22.25N MAXIMUM WITH GAGE PER SAE J567C
BULB RETENTION	4.45N MINIMUM WITH GAGE PER SAE J567C
BULB RETENTION	22.25 MAXIMUM WITH GAGE PER SAE J567C
SOCKET INSERTION	0.79 N-M NOMINAL WITH MMC GAGE
SOCKET RETENTION	0.20 N-M MINIMUM WITH A LMC GAGE
SOCKET INSERTION	2.0 N-M MAX WITH LAMP HOUSING

**A**

(11 - 16) FOCAL PT.  
FOR T-3/4 BULB

(18 - 21) FOCAL PT.  
FOR T-5 BULB

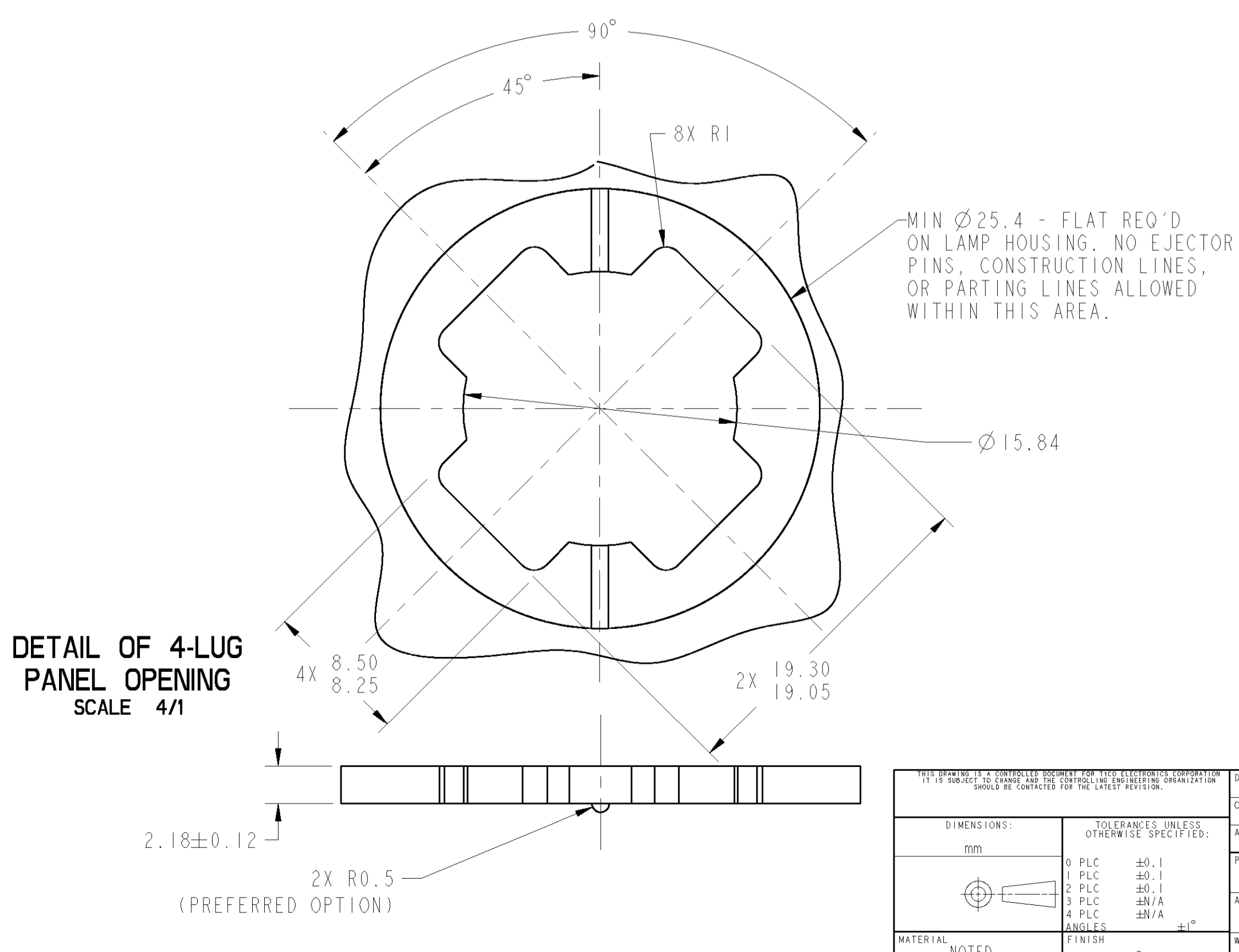
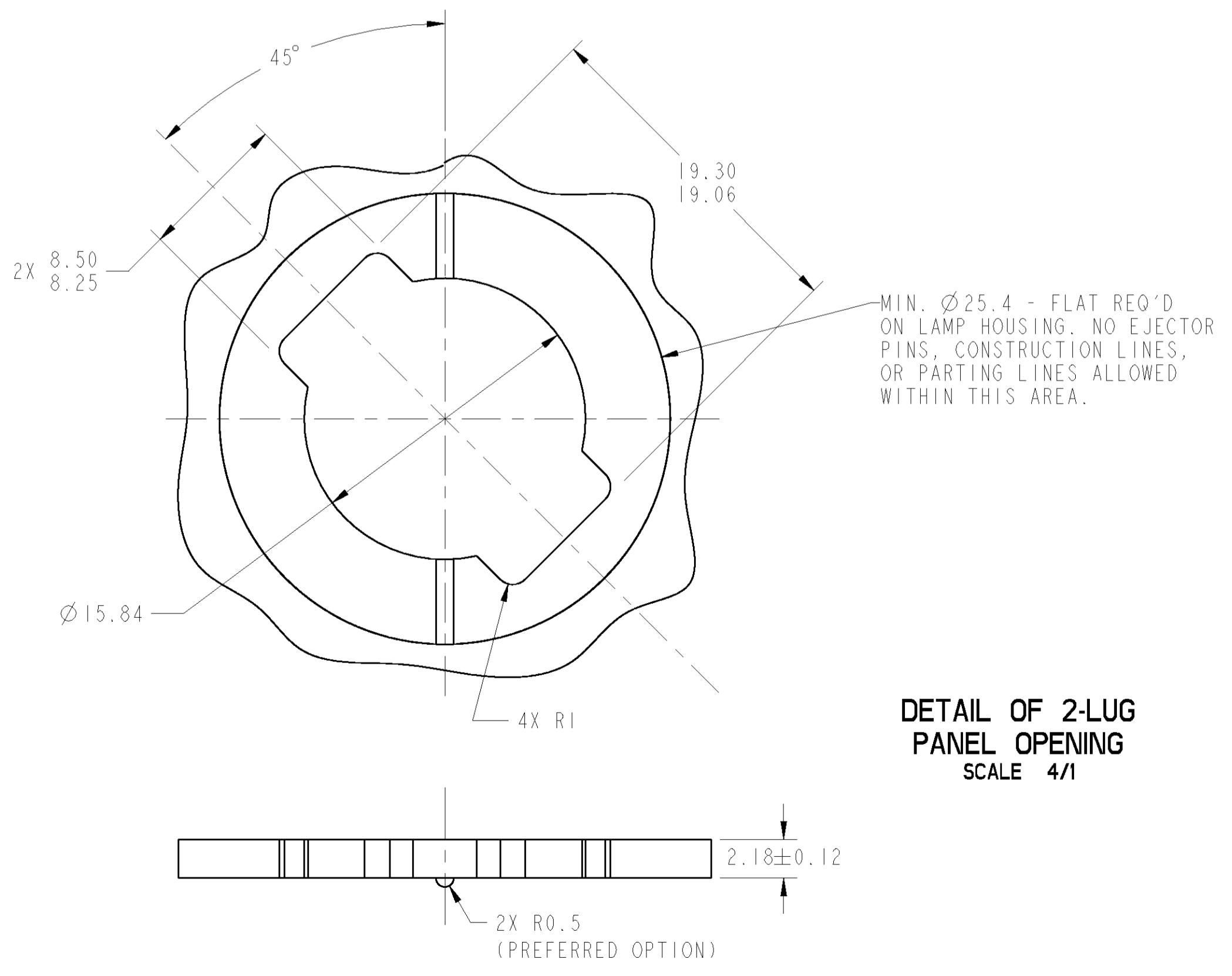
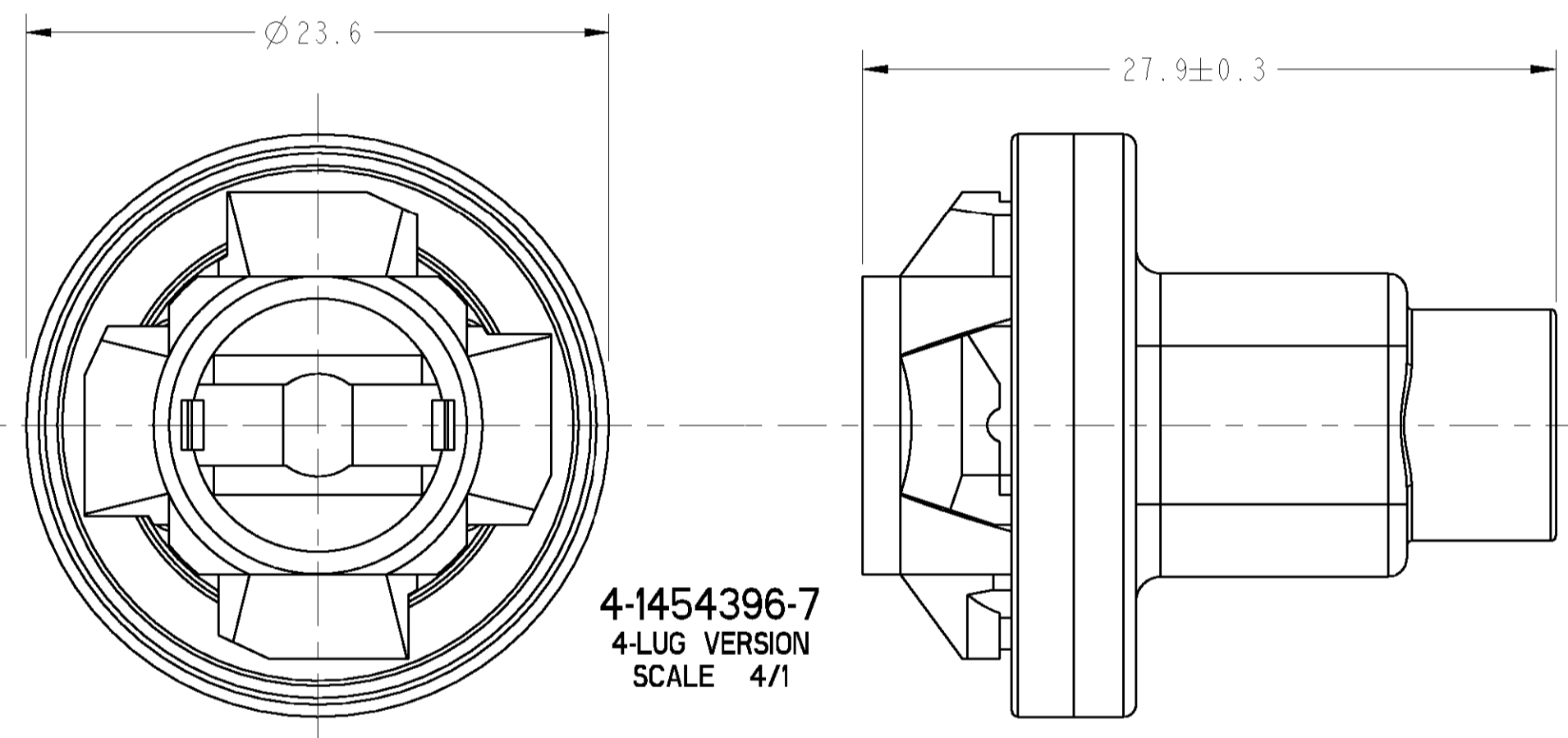
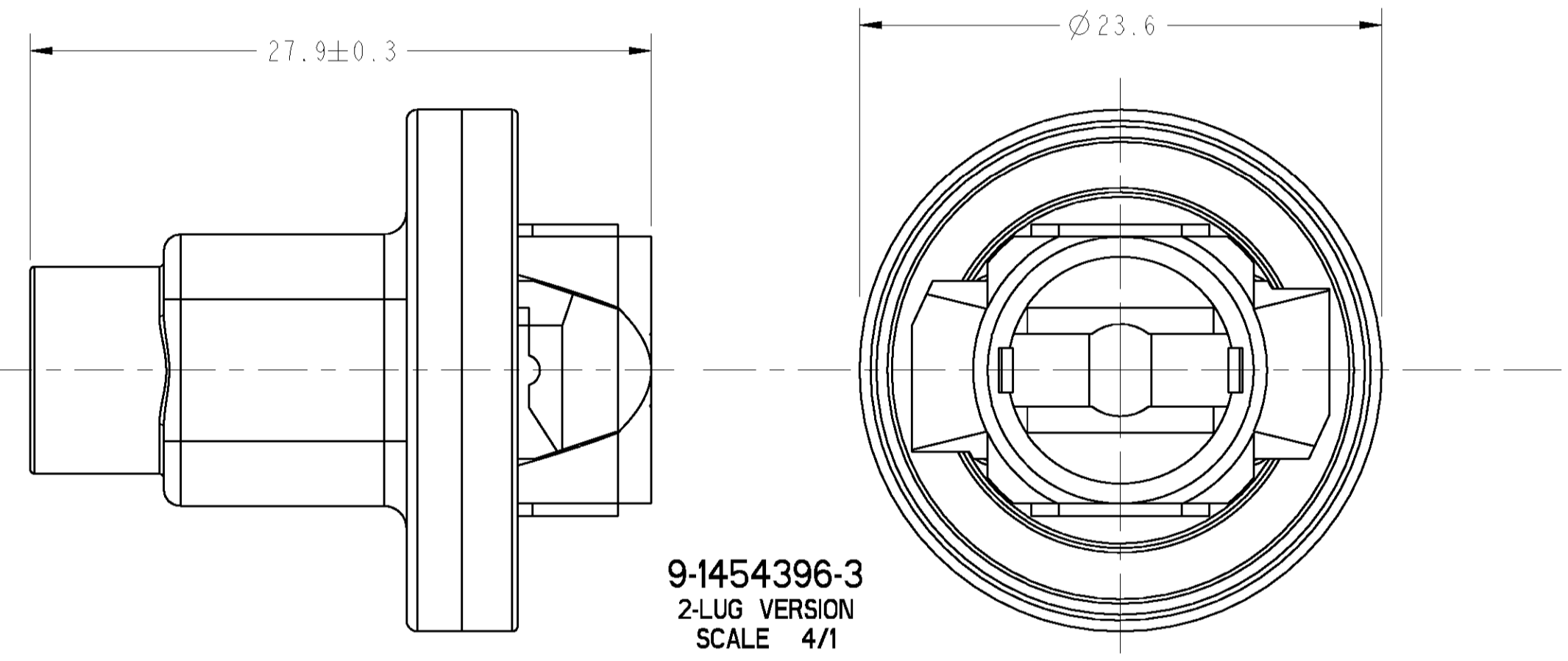

DIMENSIONS:		TOLERANCES UNLESS OTHERWISE SPECIFIED:		DWN E. LUCCI 15FEB2001		Tyco Electronics Harrisburg, PA 17105-3608	
mm		0 PLC ±0.1 1 PLC ±0.1 2 PLC ±0.1 3 PLC ±0.1 4 PLC ±N/A ANGLES ±1°		CHK S. RAHMAN 15FEB2001		APVD S. RAHMAN 15FEB2001	
MATERIAL NOTED		FINISH -		NAME P-NUT SOCKET ASSEMBLY		RESTRICTED TO	
CUSTOMER DRAWING		SCALE NOTED		SIZE A		CAGE CODE 00779	
		DRAWING NO C=4-1454396-7		REV 1		SHEET 1 OF 1	