

Data Sheet	AS07008MO-R
------------	-------------

Specifications

Parameters	Values	Units
Rated Input Power	2	Watts
Max Input Power	5	Watts
Impedance	8 ± 15%	Ohms
SPL @ 1W/0.5m (Average 0.4, 0.8, 1, 2, 4 kHz)	84 ± 3	dB
Resonant Frequency	300 ± 20%	Hz
Frequency Range (-10 dB)	150 ~ 20,000	Hz
Frame Material	Stamped Steel	-
Magnet Material	NdFeB	-
Weight	36	Grams
Ingress Protection Rating	IP55	-
Acceptable Soldering Methods	Hand Solder	-
Buzz, Rattle, etc.	Should not be audible with 4V sine wave from 500 Hz to 4 kHz	-
Environmental Compliances	RoHS 2015/863/EU, REACH 197	-
Polarity	Cone shall move forward when a positive voltage is applied to the positive terminal	-
Operating Temperature	-20 ~ +60	°C
Storage Temperature	-30 ~ +70	°C

Measurement Method (1W input power with microphone spaced at 50cm)

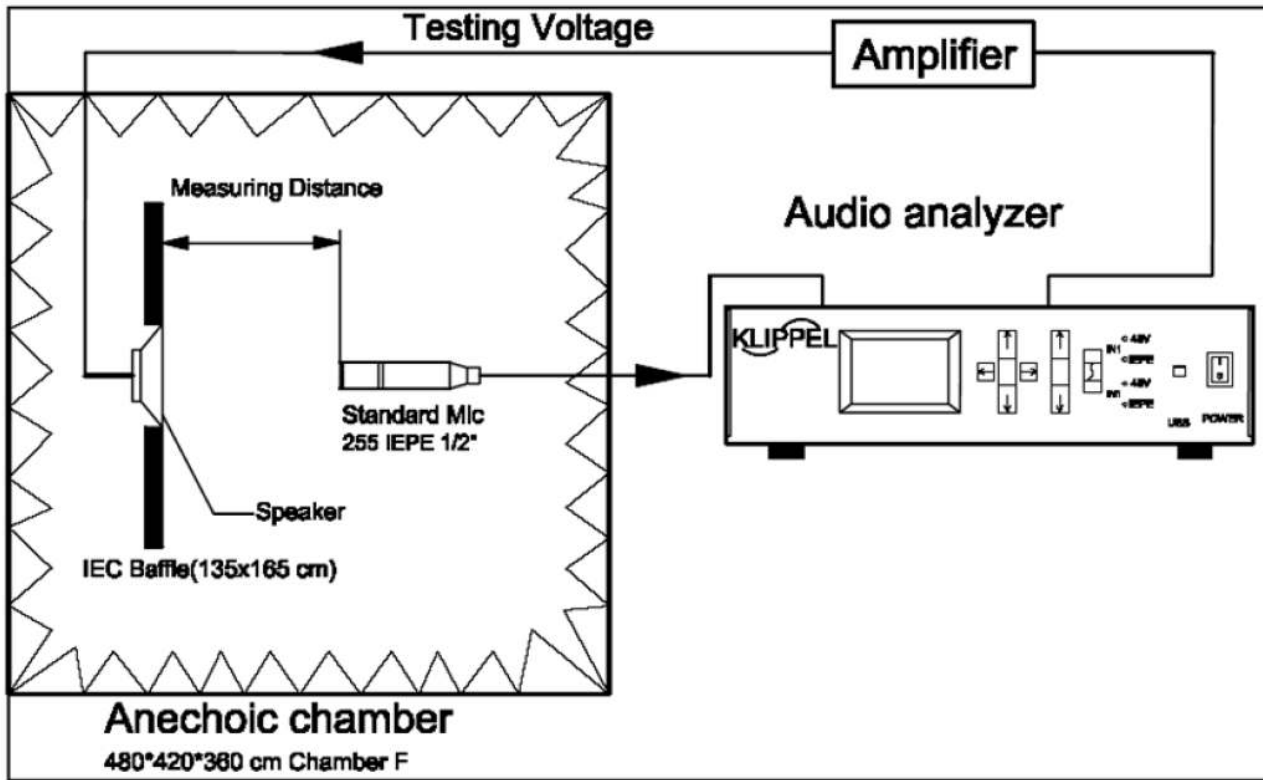

Typical Frequency Response (Tested at 1W/50cm)

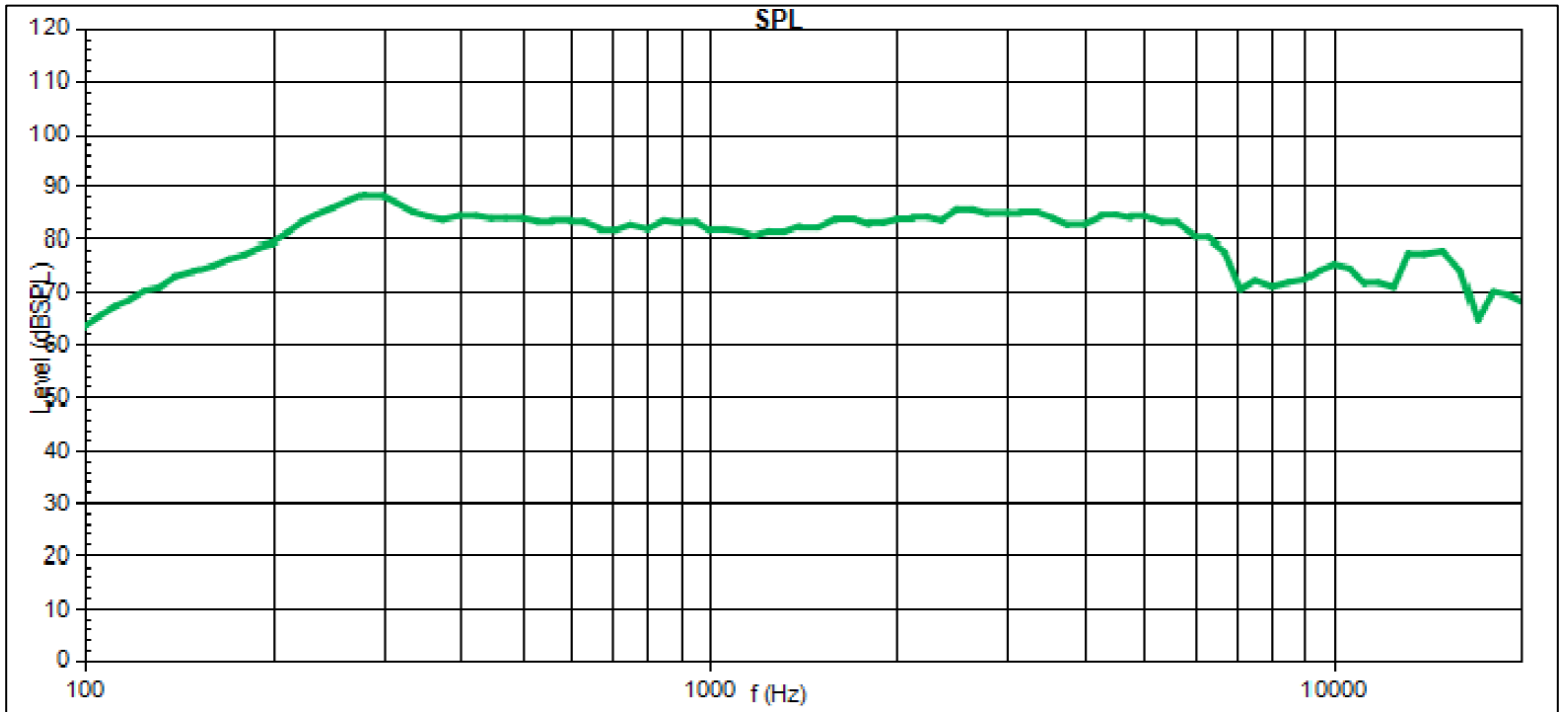

Reliability Testing

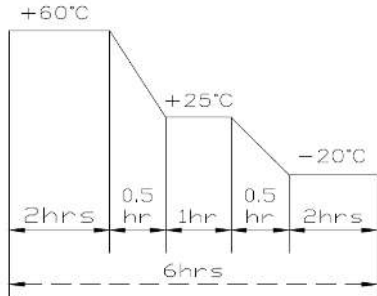
Type of Test	Test Specifications
High Temperature Test	96 hours at +70°C ± 2°C followed by three hours in normal room temperature
Low Temperature Test	96 hours at -30°C ± 3°C followed by three hours in normal room temperature
Humidity Test	96 hours at +30°C ± 2°C with relative humidity between 90% and 95% followed by 6 hours in normal room temperature
Temperature Cycle Testing	5 cycles according to the test below: 
Vibration Test	Frequency 10~55~10 Hz, Amplitude 1.5 mm for 2 Hours in each axis, X, Y, and Z.
Drop Test	75 cm free falling onto 40mm thick wooden board, 10 times.
Load Test	Speaker should not fail after applying white noise at rated power for 96 hours.

After each test, SPL shall not deviate by more than ±3 dB from pre-test measurement.

Dimensions

Diaphragm and gasket made in one piece

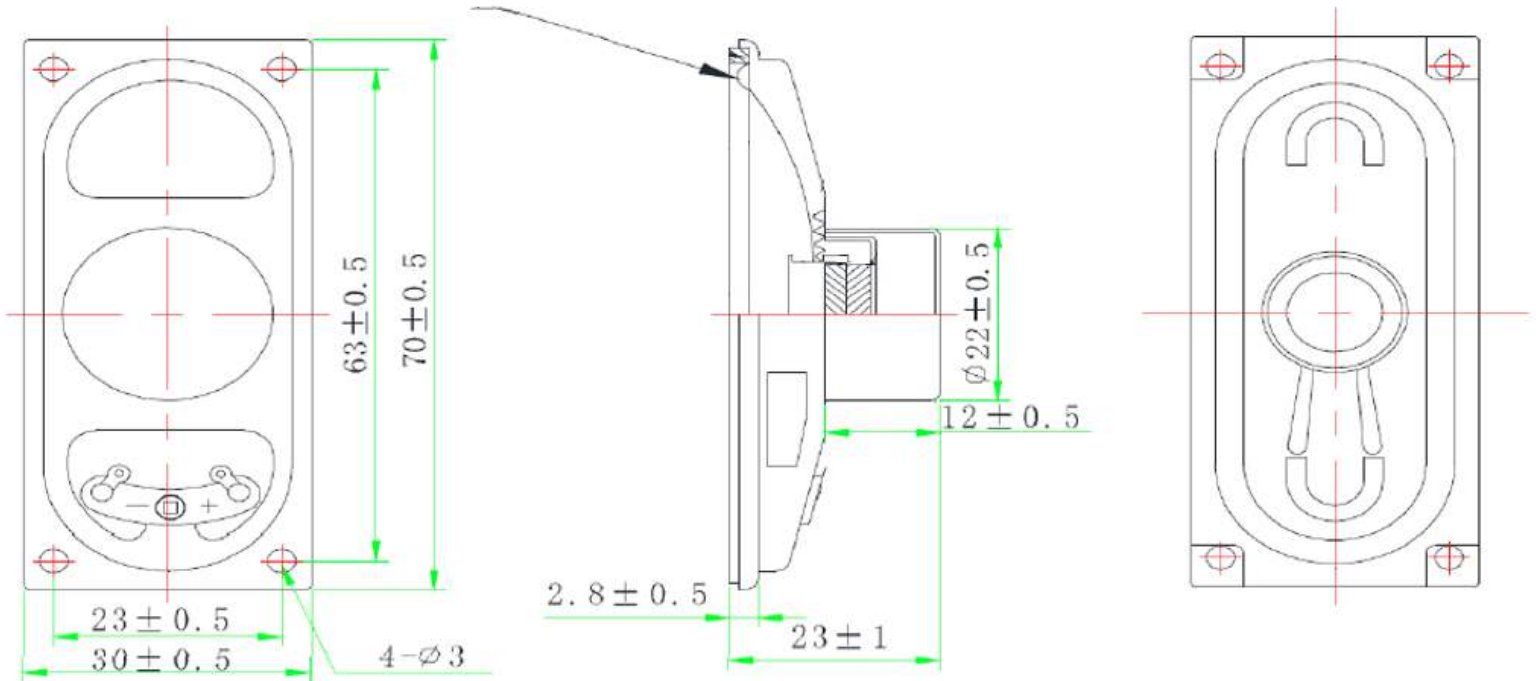

Specifications Revisions

Revision	Description	Date
-	Released from Engineering	1/3/2020
A	Revised SPL, Resonant Frequency and Frequency Response	6/4/2020

Note:

1. Unless otherwise specified:
 - A. All dimensions are in millimeters.
 - B. Default tolerances are $\pm 0.5\text{mm}$ and angles are $\pm 3^\circ$.
2. Specifications subject to change or withdrawal without notice.