

# CTHFW2918F Series

From 1.0 $\mu$ H to 33 $\mu$ H

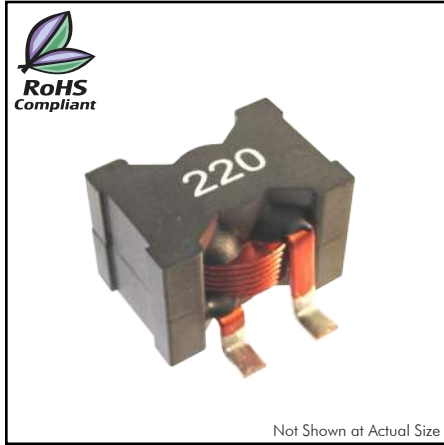

## SPECIFICATIONS

\*Isat: DC current (A) that will cause L0 to drop approximately 20%  
 \*\*Idc: DC current (A) that will cause an approximate  $\Delta T40^{\circ}C$

Part Number	Inductance $\pm 20\%$ ( $\mu$ H)	Test Freq. (kHz)	DCR Nom.(Max.) (m $\Omega$ )	*Isat Typ. (A)	**Idc Typ. (A)
CTHFW2918F-1R0M	1.00	100	0.50(0.60)	120	60.00
CTHFW2918F-1R5M	1.50	100	0.72(0.87)	110	50.00
CTHFW2918F-2R2M	2.20	100	0.72(0.87)	85.00	50.00
CTHFW2918F-3R3M	3.30	100	2.60(2.86)	91.00	28.00
CTHFW2918F-4R7M	4.70	100	2.60(2.86)	61.20	28.00
CTHFW2918F-6R8M	6.80	100	2.60(2.86)	45.00	28.00
CTHFW2918F-100M	10.00	100	2.60(2.86)	31.20	28.00
CTHFW2918F-150M	15.00	100	2.60(2.86)	21.20	28.00
CTHFW2918F-220M	22.00	100	2.60(2.86)	14.00	28.00
CTHFW2918F-330M	33.00	100	2.60(2.86)	8.70	28.00

## PHYSICAL DIMENSIONS

Size	A	B	C	D	E	F	G
	Max.	Max.	Max.	Max.			
mm	27.9	27.9	17.8	19.7	3.8 $\pm$ 0.3	6.63 $\pm$ 0.5	3.8
inches	1.10	1.10	.701	.776	.150 $\pm$ .012	.261 $\pm$ .020	.150

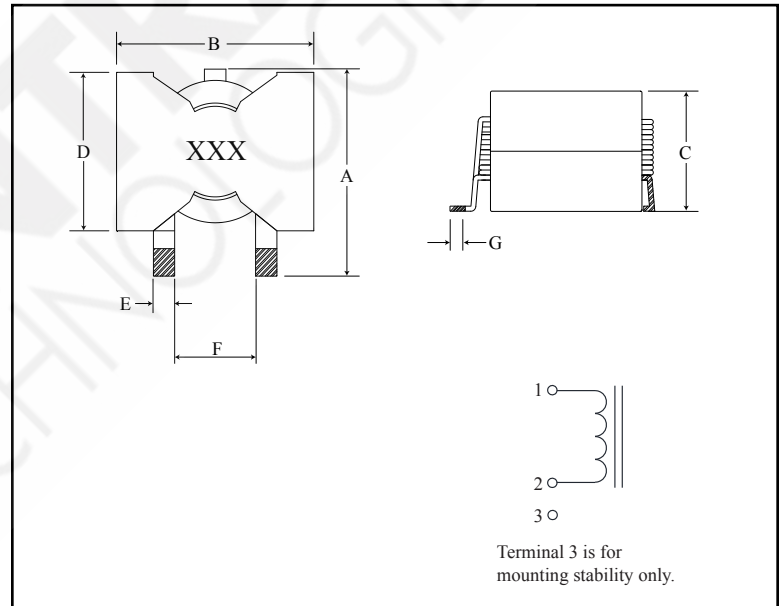

## CHARACTERISTICS

**Description:** SMD Shielded High Current Power Inductors

**Features:**

- Magnetic shielded structure, excellent resistance to electromagnetic interference.
- Sturdy construction.
- Low magnetic loss, low ESR, small parasitic capacitance.
- Closed magnetic circuit, super low buzzing, high density mount.
- The temperature rise of current and rated current less influenced by the environment.

**Applications:** Storage inductor for high efficiency DC/DC converters, Single and polyphase buck converters, Filter for audio applications, Optimized for high current boost applications, Industrial control PC's, Servers, DC/DC converters, LED lighting, Communication equipment, Navigation, etc.

**Operating Temperature:** -55 $^{\circ}C$  to +125 $^{\circ}C$  (The part temperature (ambient + temp. rise) of the product should not exceed 125 $^{\circ}C$  in bad working condition. Circuit design, component placement, PWB trace size and thickness, airflow and other cooling provisions all affect the part temperature. Part temperature should be verified in the final application.)

**Inductance Tolerance:**  $\pm 20\%$

**Testing:** Inductance at 100kHz, 0.1V

**Packaging:** Tray packaging

**Marking:** Parts are marked with inductance code.

**Miscellaneous:** **RoHS Compliant.**

**Additional Information:** Additional electrical & physical information available upon request.

**Samples available. See website for ordering information.**

## PAD LAYOUT

Unit: mm

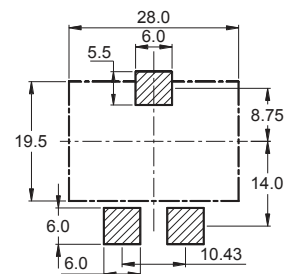

## SATURATION CURRENT VS TEMPERATURE RISE CURRENT CURVE

