

PART NUMBER	LENGTH (METERS)
CA0911G118003	0.3M (0.98 FEET)
CA0911G118005	0.5M (1.64 FEET)
CA0911G118010	1M (3.28 FEET)

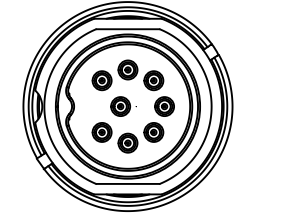
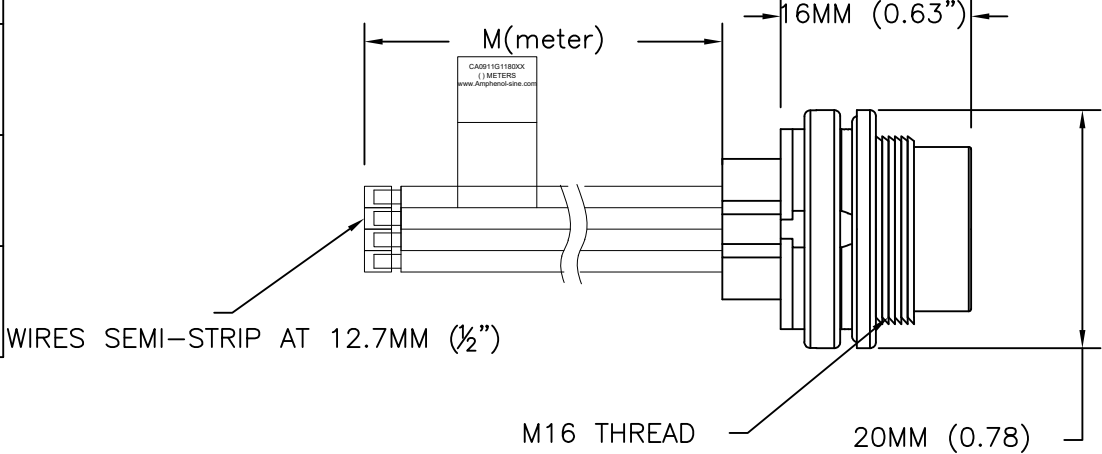

MALE RECEPTACLE

CAN BE USED WITH MATING FEMALE CABLE # CA0911B800801012

CONTACT YOUR DISTRIBUTOR FOR OTHER MATING OPTIONS

INSTALLATION NOTES & PANEL CUTOUT

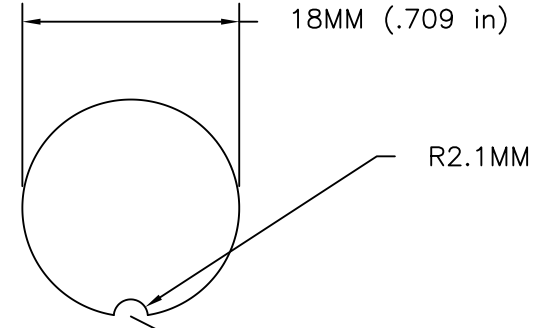

FOR SEALING REASONS THE SURFACE FOR THE GASKET NEEDS TO BE LEVEL AND FREE OF BURRS.
 PANEL THICKNESS: MAX 3.5MM
 TIGHTENING TORQUE 0.7NM
 RECOMMENDED TOOL: N450910001

WIRING DIAGRAM

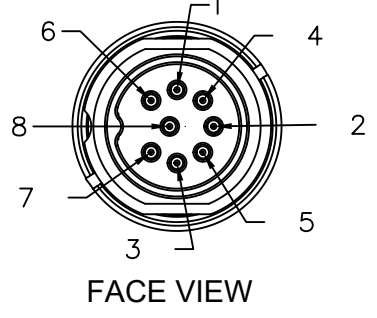
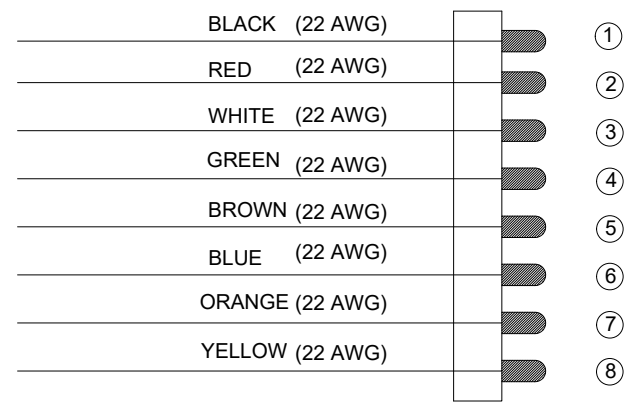

FACE VIEW

- 1) MATERIALS:
 COUPLING NUT: ZINC DIE CAST
 INSULATION INSERT: THERMOPLASTIC
 CONTACT: SILVER PLATED
 WIRE RATING: 22 AWG, UL STYLE 1569 300V 105°C (AWM), CSA TYPE TR-64 300V 90°C, UL VW-1 FLAME TEST
 CABLE JACKET MATERIAL: PVC
 NUMBER OF CONDUCTORS: (8) 22AWG
- 2) CONNECTOR ELECTRICAL DATA:
 CURRENT (MAX): 7A AT 40°C
 VOLTAGE (MAX): 300V AC/DC
 INSULATION RESISTANCE: 100M OHMS PER IEC 60512-3-1
 RATED IMPULSE WITHSTAND VOLTAGE: 1200V
- 3) CONNECTOR MECHANICAL DATA:
 TEMPERATURE RANGE: -25°C TO +100°C
 PROTECTION: IP67/IP68 (PER MATED CONDITION)
 MATING CYCLES: >500
- 4) RoHS COMPLIANT

REVISIONS						
REV	ZONE	ECO	DESCRIPTION	DATE	BY	APPR
A1	-	-	TECHNICAL DATA SHEET RELEASE	20-JULY-17	RO	-

QUANTITY	PART NUMBER	DESCRIPTION	ITEM
MATERIALS LIST			
UNLESS OTHERWISE SPECIFIED 1) All dimensions are in metric (mm). 2) Tolerances are as follows: 1 PL DEC ±0.30 Fractions ±1/64 2 PL DEC ±0.15 Angles ±1° 3 PL DEC ±0.08		SIGNATURES DATE DRAWN: RO 6-JUNE-17 CHECKED: AA 8-JUNE-17 ENGINEER: RO APPROVAL: WS 13-JUNE-17	
MATERIAL SPECIFICATIONS:		<h1 style="margin: 0;">Amphenol</h1> <p style="margin: 0;">Sine Systems - www.amphenol-sine.com 44724 Morley Drive Clinton Township, MI 48036</p>	
PROCESS SPECIFICATIONS: IPC-WHMA-A-620			
NEXT ASSY:		THIS DRAWING IS SUPPLIED FOR INFORMATION ONLY. DESIGN FEATURES, SPECIFICATIONS AND PERFORMANCE DATA SHOWN HEREON ARE THE PROPERTY OF THE AMPHENOL CORPORATION. NO RIGHTS OF REPRODUCTION ARE IMPLIED. ALL DIMENSIONS ARE SUBJECT TO NORMAL MANUFACTURING VARIATIONS. SIZE: C- DWG NO: CA0911G1180XX REVISION: A1 SCALE: HALF CA0911G1180XX SHEET 1 OF 1	

