

PART NAME	TRANSICASE	PART No.	TC-300 TO TC-303	REV. DATE	6-28-12
-----------	------------	----------	------------------	-----------	---------

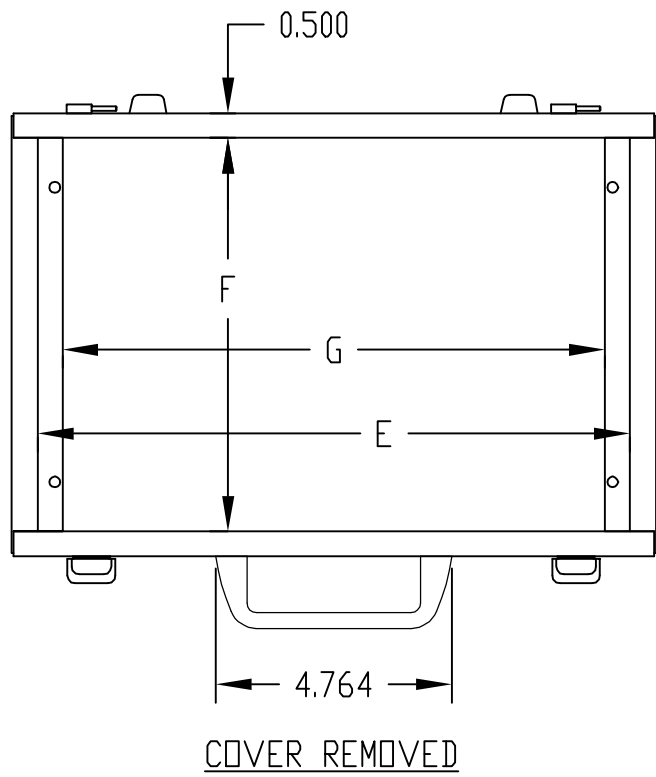
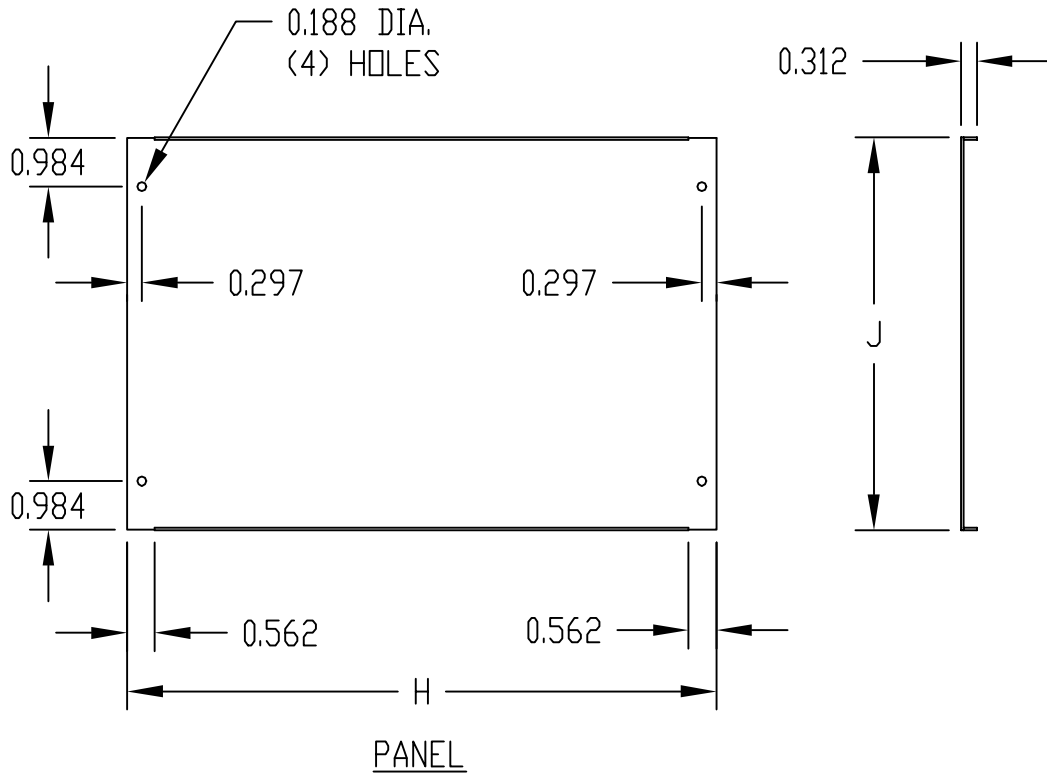

MATERIAL:

CASE BODY ASSEMBLY &
COVER BODY ASSEMBLY ____ 0.040 THK. ALUMINUM
PANEL ____ 0.050 THK. ALUMINUM
HANDLE & FEET ____ PLASTIC
CATCHES w/KEEPERS & HINGES ____ STEEL

FINISH:

CASE BODY ASSEMBLY, COVER BODY ASSEMBLY &
PANEL ____ ROYAL BLUE TEXTURED
OR GRAY TEXTURED
HANDLE & FEET ____ BLACK
CATCHES w/KEEPERS & HINGES ____ NICKEL PLATED

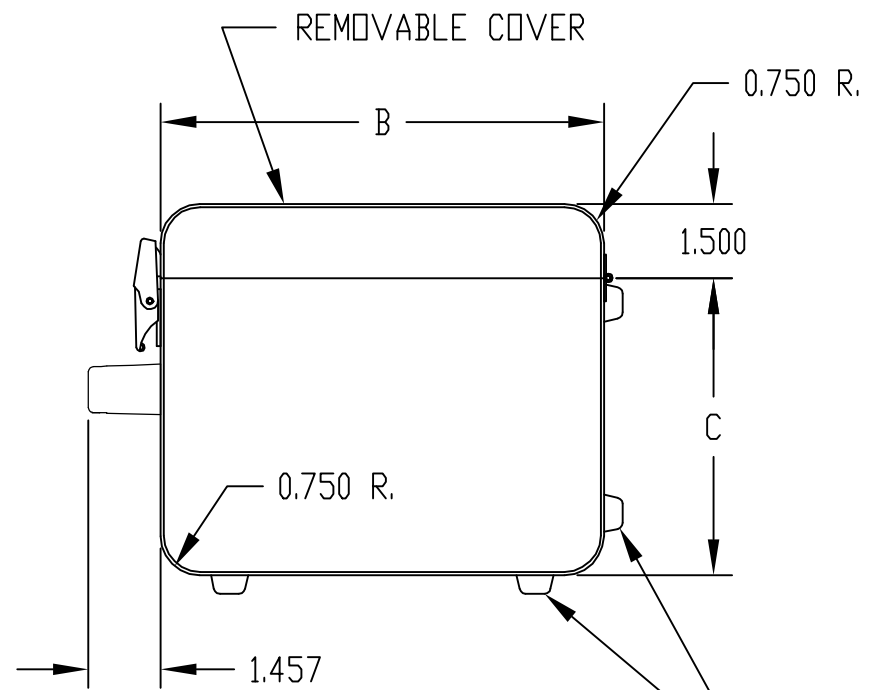
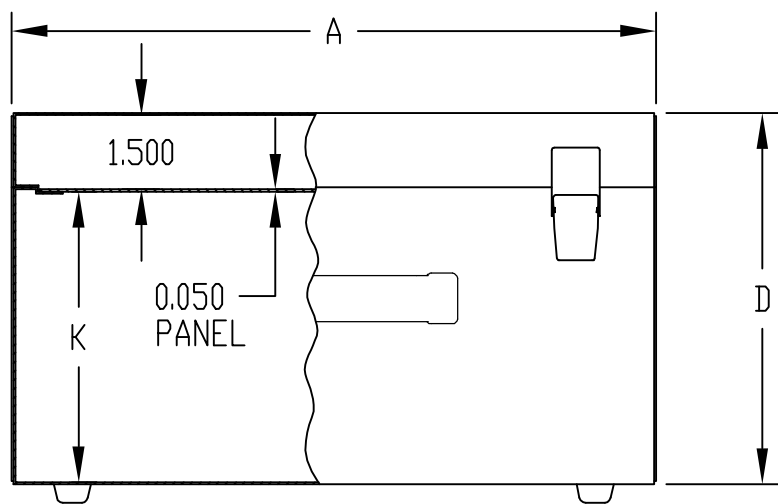

(4) PLASTIC FEET ON CASE
BOTTOM & (4) ON CASE BACK

PART No.	OVERALL				PANEL SPACE		G	PANEL		K
	A	B	C	D	E	F		H	J	
TC-300	10.062	7.000	4.500	6.000	9.000	5.938	8.000	8.968	5.938	4.375
TC-301	11.500	8.250	4.500	6.000	10.438	7.250	9.438	10.406	7.250	4.375
TC-302	13.000	9.000	6.000	7.500	11.938	7.938	10.938	11.906	7.938	5.875
TC-303	16.500	9.000	6.000	7.500	15.438	7.938	14.438	15.406	7.938	5.875