

RoHS
Ready 



AMP MCP Interconnection System for the Automotive Industry

TE
connectivity
AUTOMOTIVE



THE 5 APPLICATION AREAS



Convenience



Safety & Security
Systems



Body & Chassis
Systems

INNOVATIVE TECHNOLOGIES

TE Automotive - a business segment of TE Connectivity - follows the globalization goals of our customers, speeds up the integration of new technologies and enables our customers access to our vast product portfolio and services.

TERMINALS & CONNECTORS



TE Automotive offers a broad range of high quality terminals and connectors. Our electrical/electronic interconnection products and solutions are used to electrically and mechanically join wires and cables, printed circuit boards, integrated circuit packages and batteries. TE Automotive expanding capabilities include new copper and fiber-optic connectors, wires, cables/cable management systems that are designed to meet automotive industry demands. Our brands encompass the broadest range of connectors in the world, including high-density, high-speed designs for leading-edge communications equipment.

ALTERNATIVE POWER SYSTEMS

COMPONENTS FOR ELECTRIC VEHICLES AND INFRASTRUCTURE OF TODAY, TOMORROW AND BEYOND



TE Automotive is a leader in products for the next-generation of transportation technologies in hybrid and electric vehicles. TE Automotive is your source for high voltage power distribution, high current contact systems, high voltage connectors and special cable assemblies, high voltage relays, sensors and temperature protection devices.

As a true global player, we are supplying value from in-car applications over the charging interface up to the infrastructure and the electrical grid - everything out of one hand.

CABLE ASSEMBLY SYSTEMS



TE Automotive is your partner for special cable assemblies.

We offer research and development capabilities, prototyping, samples as well as manufacturing facilities for special cable assemblies. This includes overmold technology, semi/fully automatic manufacturing, testing equipment and appliances for handling of high volume production.

SENSORS



Contact-less measuring eliminates interference effects, wear and tear, and provides increased reliability. TE Automotive, one of the largest technology providers for the automobile industry, offers contact-less sensors for a variety of applications.

As sensor manufacturer and processing partner, TE Automotive also provides project planning support for new sensor applications, assistance in the selection of the appropriate sensor technology for the respective application, and assistance with defining the corresponding mechanical, electrical and magnetic interface.

TE Automotive has a broad electro-mechanical portfolio that includes robust housing technologies, connector systems, and temperature stable designs based on foil and cable networks. This combination of technologies and experience ensures that reliable and cost effective sensor solutions are available for all application types.

INFOTAINMENT



TE Automotive is the technology leader in high speed data communication in the automotive industry. TE Automotive offers high performance connectors based on optical, coaxial as well as shielded electrical cables.

Through a deep understanding of the technical properties and requirements of signal integrity and combined with our application knowledge both in the vehicle as well as in the logistics chain, TE Automotive is well positioned to offer the right solution for all current and next generation Infotainment Systems.

INDUCTIVE COIL SYSTEMS



TE Automotive is your source for interconnection technologies for automotive, truck and off-highway OEMs and Tier 1 suppliers. With our global design center in Belgium and manufacturing sites in all regions, TE Automotive's Inductive Systems (ICS) group is ready to design your next-generation coil modules and provide local production support.

The ICS group maintains a leading market position in braking modules and other automotive coil applications. Through early involvement with you on your next design, TE Automotive can offer the benefits of miniaturization, design-in of platform components and optimized process flow for your standard, hybrid and E.V. project needs.



TE Automotive Online

The TE Automotive website is an innovative and interactive source for application information, product updates and technical solutions. Please contact us at:
www.te.com/automotive

Internet

www.te.com
www.te.com/automotive
www.te.com/automotive/sensors
www.te.com/automotive/most

Electronic Internet Catalog

www.te.com/components

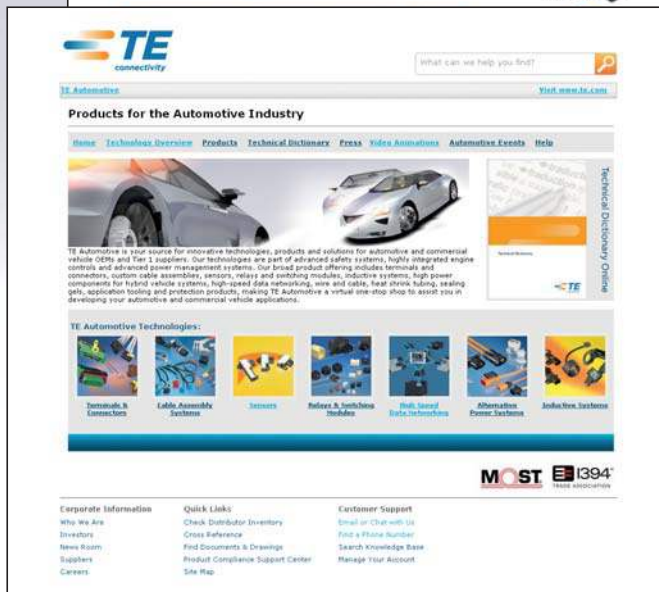

www.te.com/automotive
www.te.com/automotive/sensors
www.te.com/automotive/most



Application Tooling and Equipment

Terminals and Connector Systems for the Automotive Industry



Product and Machine Literature

TE Automotive offers a variety of product specific catalogs, brochures and high impact flyers to help better serve you!

For more information on literature for TE Automotive, please contact your local organization or go to www.te.com/automotive

Product Information Center (PIC)

You can rely on TE Connectivity's PIC Team to provide you support for answers to your general information or technical questions in an efficient and effective manner.

To reach our PIC staff, please contact your local organization or see our Global Contacts page.

Please contact us at:

<http://www.te.com/customersupport/support.asp>

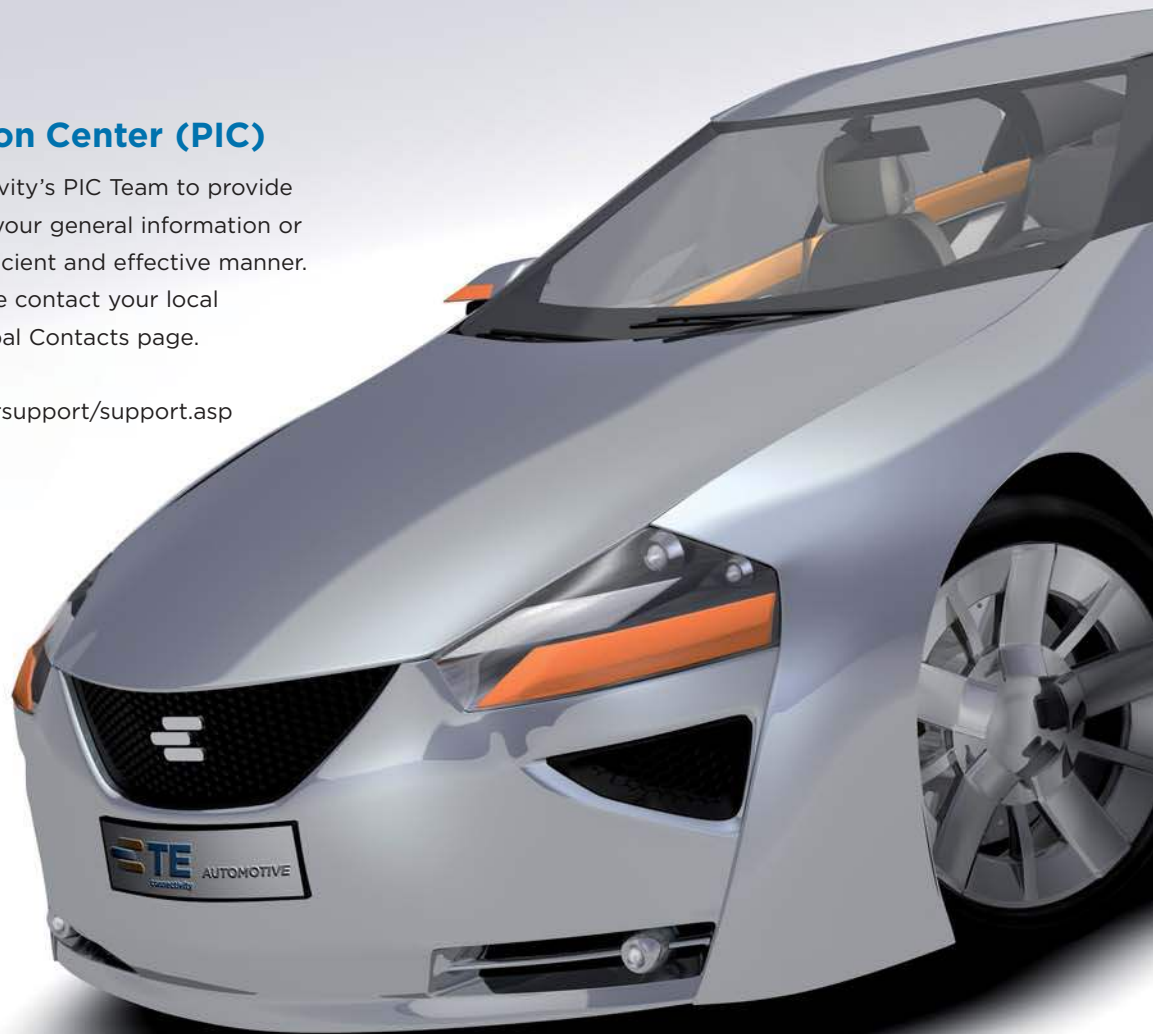

Quality Guidelines

Incorrect

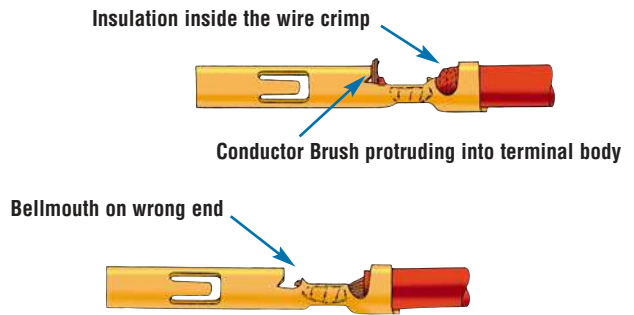
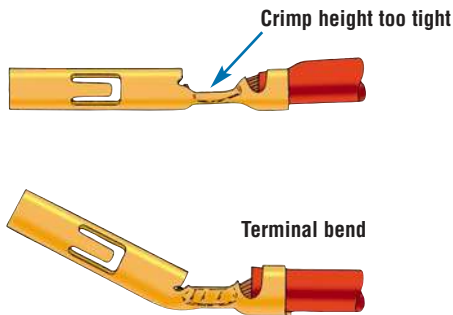
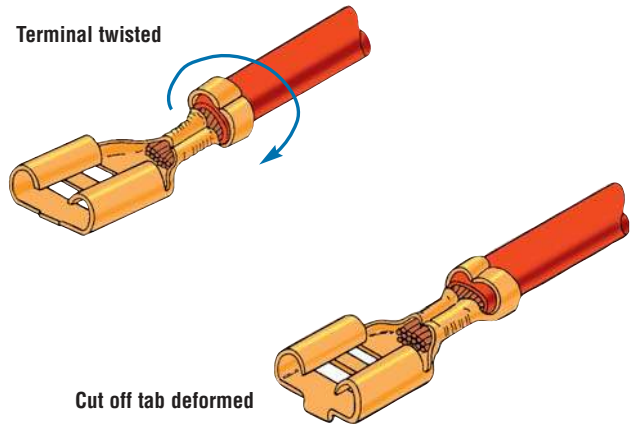
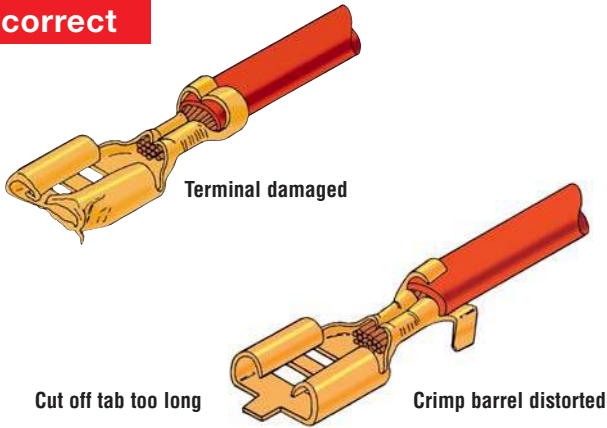

INSULATION CRIMP

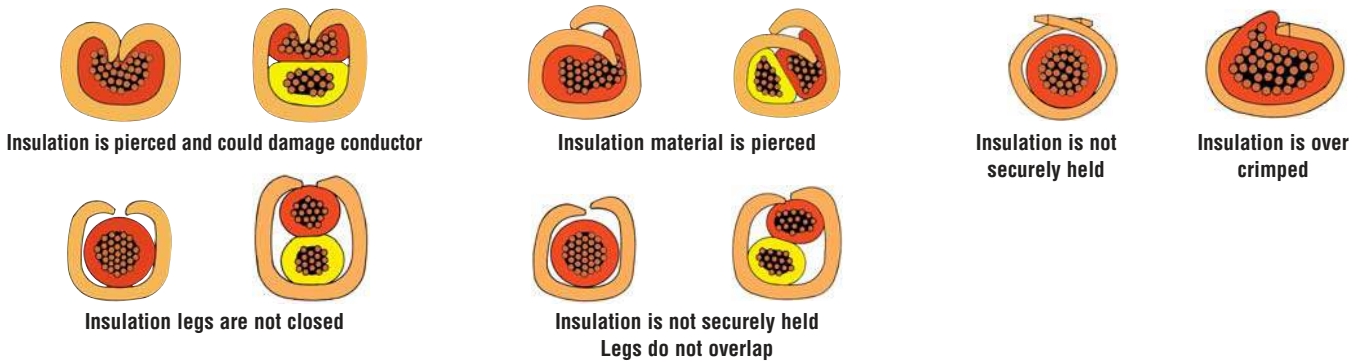

WIRE CRIMP

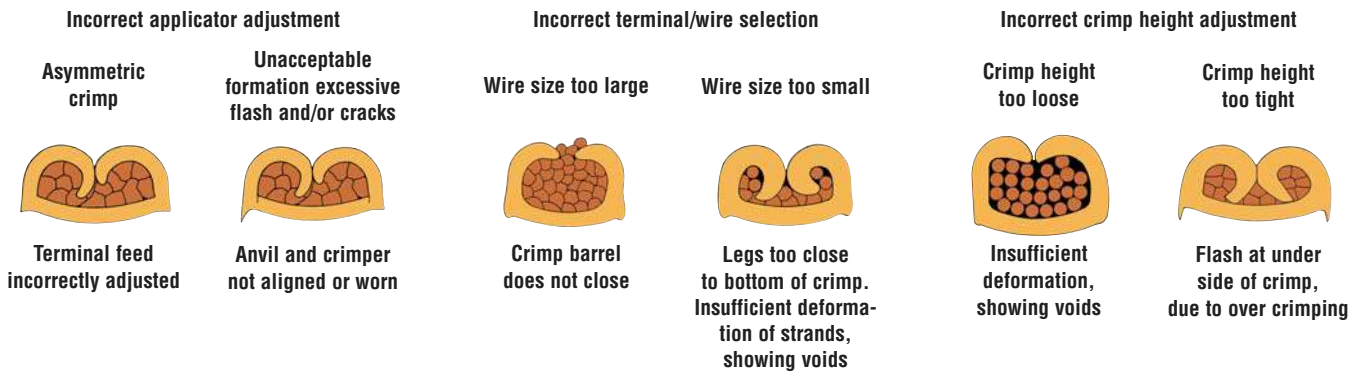

Quality Guidelines

Correct

WIRE CRIMP

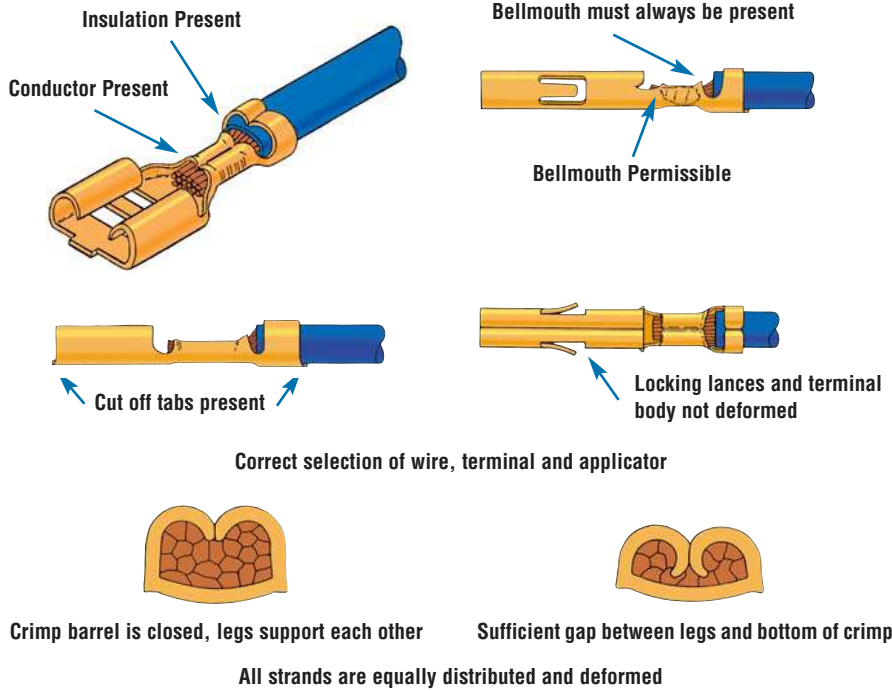

Test

WIRE CRIMP

Crimp height measurement

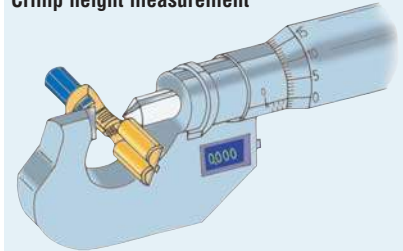

Crimp heights and tolerances

For crimp height tolerances for any given contact, please refer to the relevant application specification.

Examples:

Contact	Part No.	Wire Range (mm ²)	Tolerance (mm)	Application Spec.
MQS	962885 962886	0.2-0.5	±0.03	114-18025
JPT	927775	0.5-1.0	±0.05	114-18050
JPT	927773	1.5-2.5	±0.05	114-18050

Digital Crimp Height Micrometer
(0.001 mm increments) acc. to DIN ISO 9001
Part No. 547203-1



INSULATION CRIMP

Correct Insulation Diameter, Applicator and Terminal

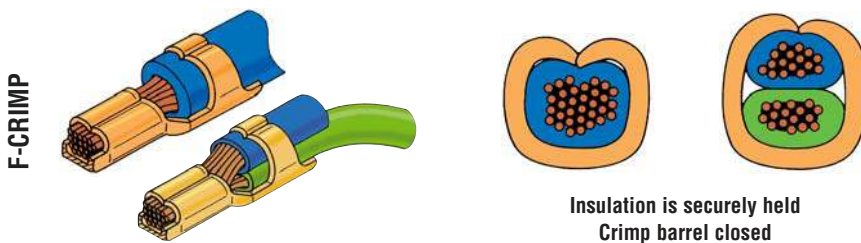

For double wire applications with different size wires always place wire with smallest outer diameter in the bottom

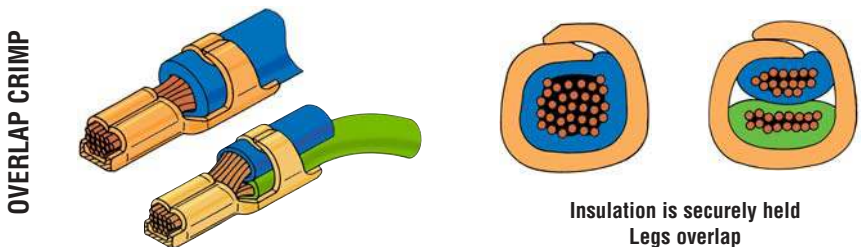

INSULATION CRIMP

Wire crimp without conductor

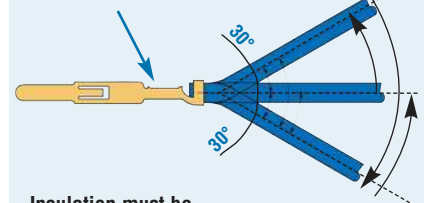

Insulation must be securely held after bend test

Restriction on the Use of Hazardous Substances (RoHS)

Restriction on the Use of Hazardous Substances (RoHS)

At TE Connectivity, we're ready to support your RoHS requirements. We've assessed more than 1.5 million end items/components for RoHS compliance, and issued new part numbers where any change was required to eliminate the restricted materials. Part numbers in this catalog are identified as:

RoHS Compliant

Part numbers in this catalog are RoHS Compliant, unless marked otherwise.

These products comply with European Union Directive 2002/95/EC as amended 1 January 2006 that restricts the use of lead, mercury, cadmium, hexavalent chromium, PBB, and PBDE in certain electrical and electronic products sold into the EU as of 1 July 2006.

Note: For purposes of this Catalog, included within the definition of RoHS Compliant are products that are clearly "Out of Scope" of the RoHS Directive such as hand tools and other non-electrical accessories.

Non-RoHS Compliant

These part numbers are identified with a "◆" symbol. These products do not comply with the material restrictions of the European Union Directive 2002/95/EC.

5 of 6 Compliant

A "●" symbol identifies these part numbers. These products do not fully comply with the European Union Directive 2002/95/EC because they contain lead in solderable interfaces (they do not contain any of the other five restricted substances above allowable limits). However, these products may be suitable for use in RoHS applications where there is an application-based exception for lead in solders, such as the server, storage, or networking infrastructure exemption.

Note: Information regarding RoHS compliance is provided based on reasonable inquiry of our suppliers and represents our current actual knowledge based on the information provided by our suppliers. This information is subject to change. For latest compliance status, refer to our website referenced below.

Getting the Information You Need

Our comprehensive on-line RoHS Customer Support Center provides a forum to answer your questions and support your RoHS needs. A RoHS FAQ (Frequently Asked Questions) is available with links to more detailed information. You can also submit RoHS questions and receive a response within 24 hours during a normal work week. The Support Center also provides:

- Cross-Reference from Non-compliant to Compliant Products
- Ability to browse RoHS Compliant Products in our on-line catalog: <http://www.te.com/commerce/alt/RohsAltHome.do>
- Downloadable Technical Data Customer Information Presentation
- More detailed information regarding the definitions used above

RoHS
Customer
Support
Center 

So whatever your questions when it comes to RoHS, we've got the answers at <http://www.te.com/customersupport/rohssupportcenter/>

AWG Conversion Table (Average Value)

Conversion Tables

Most of the wire size ranges are mentioned in mm², as well as the insulation diameters which are in many cases only in mm's.

We therefore included the conversion tables on page X and page XI.

Please note that wire and insulation sizes are for guidance only.

Consult the customer drawing for precise detail.

AWG Code	Diameter (Inch)	Diameter (mm)	F (mm ²)
000000	0.5800	14.733	170.0
00000	0.5165	13.13	135.0
0000	0.4600	11.684	103.8
000	0.4096	10.40	79.0
00	0.3648	9.27	67.5
0	0.3249	8.25	53.4
1	0.2893	7.34	42.2
2	0.2576	6.55	33.7
3	0.2294	5.82	26.6
4	0.2043	5.18	21.0
5	0.1819	4.62	16.9
6	0.1620	4.115	13.25
7	0.1443	3.66	10.25
8	0.1285	3.26	8.34
9	0.1144	2.90	6.6
10	0.1019	2.59	5.27
11	0.0907	2.30	4.15
12	0.0808	2.05	3.3
13	0.0720	1.83	2.63
14	0.0641	1.63	2.08
15	0.0571	1.45	1.65
16	0.0508	1.29	1.305
17	0.0453	1.14	1.01
18	0.0403	1.02	0.79
19	0.0359	0.91	0.65
20	0.0320	0.81	0.51
21	0.0285	0.72	0.407
22	0.0253	0.64	0.32
23	0.0226	0.57	0.255
24	0.0201	0.51	0.205
25	0.0179	0.455	0.162
26	0.0159	0.40	0.125
27	0.0142	0.36	0.102
28	0.0126	0.320	0.08
29	0.0113	0.287	0.0646
30	0.0100	0.254	0.0516
31	0.0089	0.226	0.04
32	0.0080	0.203	0.0324
33	0.0071	0.180	0.0255
34	0.0063	0.160	0.02
35	0.0056	0.142	0.0158
36	0.0050	0.127	0.0127
37	0.0045	0.114	0.01
38	0.0040	0.101	0.008
39	0.0035	0.089	0.0062
40	0.0031	0.079	0.0049
41	0.0028	0.071	0.00395
42	0.0025	0.064	0.00321
43	0.0022	0.056	0.00246
44	0.00198	0.050	0.00196
45	0.00176	0.045	
46	0.00157	0.040	
47	0.00140	0.036	
48	0.00124	0.031	
49	0.00110	0.028	
50	0.00099	0.025	

FLK/FLR Cable

FLK and FLR stand for German DIN (72551) abbreviations.

FLK means:

In German:
 • Fahrzeug Leitung Kunststoff

In English:
 • Vehicle Cable Plastic

FLR means:

In German:
 • Fahrzeug Leitung Reduziert

In English:
 • Thin Walled Cable
 (reduced insulation thickness)

Remark: Starting from 0.03 mm² (AWG 32) a wire can be crimped.





Conversion Table – Inch/mm

Inch	0	0.001	0.002	0.003	0.004	0.005	0.006	0.007	0.008	0.009
0	0	0.0254	0.0508	0.0762	0.1016	0.1270	0.1524	0.1778	0.2032	0.2286
0.010	0.2540	0.2794	0.3048	0.3302	0.3556	0.3810	0.4064	0.4318	0.4572	0.4826
0.020	0.5080	0.5334	0.5588	0.5842	0.6096	0.6350	0.6604	0.6858	0.7112	0.7366
0.030	0.7620	0.7874	0.8128	0.8382	0.8636	0.8890	0.9144	0.9398	0.9652	0.9906
0.040	1.0160	1.0414	1.0668	1.0922	1.1176	1.1430	1.1684	1.1938	1.2192	1.2446
0.050	1.2700	1.2954	1.3208	1.3462	1.3716	1.3970	1.4224	1.4478	1.4732	1.4986
0.060	1.5240	1.5494	1.5748	1.6002	1.6256	1.6510	1.6764	1.7018	1.7272	1.7526
0.070	1.7780	1.8034	1.8288	1.8542	1.8796	1.9050	1.9304	1.9558	1.9812	2.0066
0.080	2.0320	2.0574	2.0828	2.1062	2.1336	2.1590	2.1844	2.2098	2.2352	2.2606
0.090	2.2860	2.3114	2.3368	2.3622	2.3876	2.4130	2.4384	2.4638	2.4892	2.5146
0.100	2.5400	2.5654	2.5908	2.6162	2.6416	2.6670	2.6924	2.7178	2.7432	2.7686
0.110	2.7940	2.8194	2.8448	2.8702	2.8956	2.9210	2.9464	2.9718	2.9972	3.0226
0.120	3.0480	3.0734	3.0988	3.1242	3.1496	3.1750	3.2004	3.2258	3.2512	3.2766
0.130	3.3020	3.3274	3.3528	3.3782	3.4036	3.4290	3.4544	3.4798	3.5052	3.5306
0.140	3.5560	3.5814	3.6068	3.6322	3.6576	3.6830	3.7084	3.7338	3.7592	3.7846
0.150	3.8100	3.8354	3.8608	3.8862	3.9116	3.9370	3.9624	3.9878	4.0132	4.0386
0.160	4.0640	4.0894	4.1148	4.1402	4.1656	4.1910	4.2164	4.2418	4.2672	4.2926
0.170	4.3180	4.3434	4.3688	4.3942	4.4196	4.4450	4.4704	4.4958	4.5212	4.5466
0.180	4.5720	4.5974	4.6228	4.6482	4.6736	4.6990	4.7244	4.7498	4.7752	4.8006
0.190	4.8260	4.8514	4.8768	4.9022	4.9276	4.9530	4.9784	5.0038	5.0292	5.0546
0.200	5.0800	5.1054	5.1308	5.1562	5.1816	5.2070	5.2324	5.2578	5.2832	5.3086
0.210	5.3340	5.3594	5.3848	5.4102	5.4356	5.4610	5.4864	5.5118	5.5372	5.5626
0.220	5.5880	5.6134	5.6388	5.6642	5.6896	5.7150	5.7404	5.7658	5.7912	5.8166
0.230	5.8420	5.8674	5.8928	5.9182	5.9436	5.9690	5.9944	6.0198	6.0452	6.0706
0.240	6.0960	6.1214	6.1468	6.1722	6.1976	6.2230	6.2484	6.2738	6.2992	6.3246
0.250	6.3500	6.3754	6.4008	6.4262	6.4516	6.4770	6.5024	6.5278	6.5532	6.5786
0.260	6.6040	6.6294	6.6548	6.6802	6.7056	6.7310	6.7564	6.7818	6.8072	6.8326
0.270	6.8580	6.8834	6.9088	6.9342	6.9596	6.9850	7.0104	7.0358	7.0612	7.0866
0.280	7.1120	7.1374	7.1628	7.1882	7.2136	7.2390	7.2644	7.2898	7.3152	7.3406
0.290	7.3660	7.3914	7.4168	7.4422	7.4676	7.4930	7.5184	7.5438	7.5692	7.5946
0.300	7.6200	7.6454	7.6708	7.6962	7.7216	7.7470	7.7724	7.7978	7.8232	7.8486
0.310	7.8740	7.8994	7.9248	7.9502	7.9756	8.0010	8.0264	8.0518	8.0772	8.1026
0.320	8.1280	8.1534	8.1788	8.2042	8.2296	8.2550	8.2804	8.3058	8.3312	8.3566
0.330	8.3820	8.4074	8.4328	8.4582	8.4836	8.5090	8.5344	8.5598	8.5852	8.6106
0.340	8.6360	8.6614	8.6868	8.7122	8.7376	8.7630	8.7884	8.8138	8.8392	8.8646
0.350	8.8900	8.9154	8.9408	8.9662	8.9916	9.0170	9.0424	9.0678	9.0932	9.1186
0.360	9.1440	9.1694	9.1948	9.2202	9.2456	9.2710	9.2964	9.3218	9.3472	9.3726
0.370	9.3980	9.4234	9.4488	9.4742	9.4996	9.5250	9.5504	9.5758	9.6012	9.6266
0.380	9.6520	9.6774	9.7028	9.7282	9.7536	9.7790	9.8044	9.8298	9.8552	9.8806
0.390	9.9060	9.9314	9.9568	9.9822	10.0076	10.0330	10.0584	10.0838	10.1092	10.1346
0.400	10.1600	10.1854	10.2108	10.2362	10.2616	10.2870	10.3124	10.3378	10.3632	10.3886
0.410	10.4140	10.4394	10.4648	10.4902	10.5156	10.5410	10.5664	10.5918	10.6172	10.6426
0.420	10.6680	10.6934	10.7188	10.7442	10.7696	10.7950	10.8204	10.8458	10.8712	10.8966
0.430	10.9220	10.9474	10.9728	10.9982	11.0236	11.0490	11.0744	11.0998	11.1252	11.1506
0.440	11.1760	11.2014	11.2268	11.2522	11.2776	11.3030	11.3284	11.3538	11.3792	11.4046
0.450	11.4300	11.4554	11.4808	11.5062	11.5316	11.5510	11.5824	11.6078	11.6332	11.6586
0.460	11.6840	11.7094	11.7348	11.7602	11.7856	11.8110	11.8364	11.8618	11.8872	11.9126
0.470	11.9380	11.9634	11.9888	12.0142	12.0396	12.0650	12.0904	12.1158	12.1412	12.1666
0.480	12.1920	12.2174	12.2428	12.2682	12.2936	12.3190	12.3444	12.3698	12.3952	12.4206
0.490	12.4460	12.4714	12.4968	12.5222	12.5476	12.5730	12.5984	12.6238	12.6492	12.6746
0.500	12.7000									
Inch	0	0.001	0.002	0.003	0.004	0.005	0.006	0.007	0.008	0.009





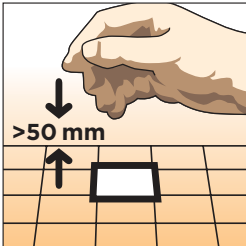

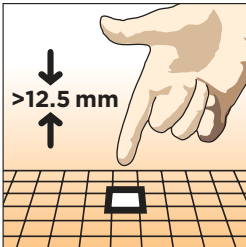
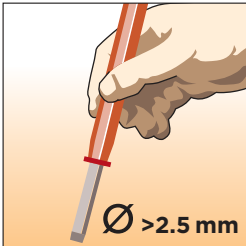
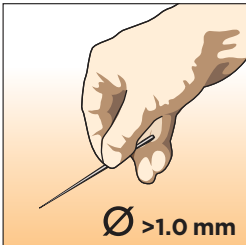

Conversion Table – Inch/mm (continued)

Inch	0	0.001	0.002	0.003	0.004	0.005	0.006	0.007	0.008	0.009
0.500	12.7000	12.7254	12.7508	12.7762	12.8016	12.8270	12.8524	12.8778	12.9032	12.9286
0.510	12.9540	12.9794	13.0048	13.0302	13.0556	13.0810	13.1064	13.1318	13.1572	13.1826
0.520	13.2080	13.2334	13.2588	13.2842	13.3096	13.3350	13.3604	13.3858	13.4112	13.4366
0.530	13.4620	13.4874	13.5128	15.5382	13.5636	13.5890	13.6144	13.6398	13.6652	13.6906
0.540	13.7160	13.7414	13.7668	13.7922	13.8176	13.8430	13.8684	13.8938	13.9192	13.9446
0.550	13.9700	13.9954	14.0208	14.0462	14.0716	14.0970	14.1224	14.1478	14.1732	14.1986
0.560	14.2240	14.2494	14.2748	14.3002	14.3256	14.3510	14.3764	14.4018	14.4272	14.4526
0.570	14.4780	14.5034	14.5288	14.5542	14.5796	14.6050	14.6304	14.6558	14.6812	14.7066
0.580	14.7320	14.7574	14.7828	14.8082	14.8336	14.8590	14.8844	14.9098	14.9352	14.9606
0.590	14.9860	15.0114	15.0368	15.0622	15.0876	15.1130	15.1384	15.1638	15.1892	15.2146
0.600	15.2400	15.2654	15.2908	15.3162	15.3416	15.3670	15.3924	15.4178	15.4432	15.4686
0.610	15.4940	15.5194	15.5448	15.5702	15.5956	15.6210	15.6464	15.6718	15.6972	15.7226
0.620	15.7480	15.7734	15.7988	15.8242	15.8496	15.8750	15.9004	15.9258	15.9512	15.9766
0.630	16.0020	16.0274	16.0528	16.0782	16.1036	16.1290	16.1544	16.1798	16.2052	16.2306
0.640	16.2560	16.2814	16.3068	16.3322	16.3576	16.3830	16.4084	16.4338	16.4592	16.4846
0.650	16.5100	16.5354	16.5608	16.5862	16.6116	16.6370	16.6624	16.6878	16.7132	16.7386
0.660	16.7640	16.7894	16.8148	16.8402	16.8656	16.8910	16.9164	16.9418	16.9672	16.9926
0.670	17.0180	17.0434	17.0688	17.0942	17.1196	17.1450	17.1704	17.1958	17.2212	17.2466
0.680	17.2720	17.2974	17.3228	17.3482	17.3736	17.3990	17.4244	17.4498	17.4752	17.5006
0.690	17.5260	17.5514	17.5768	17.6022	17.6276	17.6530	17.6784	17.7038	17.7292	17.7546
0.700	17.7800	17.8054	17.8308	17.8562	17.8816	17.9070	17.9324	17.9528	17.9832	18.0086
0.710	18.0340	18.0594	18.0848	18.1102	18.1356	18.1610	18.1864	18.2118	18.2372	18.2626
0.720	18.2880	18.3134	18.3388	18.3642	18.3896	18.4150	18.4404	18.4658	18.4912	19.5166
0.730	18.5420	18.5674	18.5928	18.6182	18.6436	18.6690	18.6944	18.7198	18.7452	18.7706
0.740	18.7960	18.8214	18.8468	18.8722	18.8976	18.9230	18.9484	18.9738	18.9992	19.0246
0.750	19.0500	19.0754	19.1008	19.1262	19.1516	19.1170	19.2024	19.2278	19.2532	19.2786
0.760	19.3040	19.3294	19.3548	19.3802	19.4056	19.4310	19.4564	19.4818	19.5072	19.5326
0.770	19.5580	19.5834	19.6088	19.6342	19.6596	19.6850	19.7104	19.7358	19.7612	19.7866
0.780	19.8120	19.8374	19.8628	19.8882	19.9136	19.9390	19.9644	19.9898	20.0152	20.0406
0.790	20.0660	20.0914	20.1168	20.1422	20.1676	20.1930	20.2184	20.2438	20.2692	20.2946
0.800	20.3200	20.3454	20.3708	20.3962	20.4216	20.4470	20.4724	20.4978	20.5232	20.5486
0.810	20.5740	20.5994	20.6248	20.6502	20.6756	20.7010	20.7264	20.7518	20.7772	20.8026
0.820	20.8280	20.8534	20.8788	20.9042	20.9296	20.9550	20.9804	21.0058	21.0312	21.0566
0.830	21.0820	21.1074	21.1328	21.1582	21.1836	21.2090	21.2344	21.2598	21.2852	21.3106
0.840	21.3360	21.3614	21.3868	21.4122	21.4376	21.4630	21.4884	21.5138	21.5392	21.5646
0.850	21.5900	21.6154	21.6408	21.6662	21.6916	21.7170	21.7424	21.7678	21.7932	21.8186
0.860	21.8440	21.8694	21.8948	21.9202	21.9456	21.9710	21.9964	22.0218	22.0472	22.0726
0.870	22.0980	22.1234	22.1488	22.1742	22.1996	22.2250	22.2504	22.2758	22.3012	22.3266
0.880	22.3520	22.3774	22.4028	22.4282	22.4536	22.4790	22.5044	22.5298	22.5552	22.5806
0.890	22.6060	22.6314	22.6568	22.6822	22.7076	22.7330	22.7584	22.7838	22.8092	22.8346
0.900	22.8600	22.8854	22.9108	22.9362	22.9616	22.9870	23.0124	23.0378	23.0632	23.0886
0.910	23.1140	23.1394	23.1648	23.1902	23.2156	23.2410	23.2664	23.2918	23.3172	23.3426
0.920	23.3680	23.3934	23.4188	23.4442	23.4696	23.4950	23.5204	23.5458	23.5712	23.5966
0.930	23.6220	23.6474	23.6728	23.6982	23.7236	23.7490	23.7744	23.7998	23.8252	23.8506
0.940	23.8760	23.9014	23.9268	23.9522	23.9776	24.0030	24.0284	24.0538	24.0792	24.1046
0.950	24.1300	24.1554	24.1808	24.2062	24.2316	24.2570	24.2824	24.3078	24.3332	24.3586
0.960	24.3840	24.4094	24.4348	24.4602	24.4856	24.5110	24.5364	24.5618	24.5872	24.6126
0.970	24.6380	24.6634	24.6888	24.7142	24.7396	24.7650	24.7904	24.8158	24.8412	24.8666
0.980	24.8920	24.9174	24.9428	24.9682	24.9936	25.0190	25.0444	25.0698	25.0952	25.1206
0.990	25.1460	25.1714	25.1968	25.2222	25.2476	25.2730	25.2984	25.3228	25.3492	25.3746
1.000	25.4000									
Inch	0	0.001	0.002	0.003	0.004	0.005	0.006	0.007	0.008	0.009

IP Code (Elements and Significance acc. to IEC 60529 and DIN 40050)

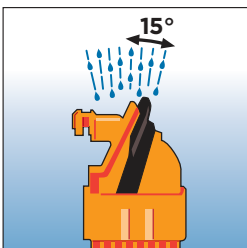
1st Digit	Against Foreign Objects (incl. Dust)	1st Digit	Against Foreign Objects (incl. Dust)
0	 <p>Not protected.</p>	5K	 <p>Dust protected.</p>
1	 <p>Protected against solid objects greater than 50 mm (ex. Back of hand).</p>	6K	 <p>Dust tight.</p>
2	 <p>Protected against solid objects greater than 12.5 mm (ex. Finger).</p>		
3	 <p>Protected against solid objects greater than 2.5 mm (ex. Tool).</p>		
4	 <p>Protected against solid objects greater than 1.0 mm (ex. Wire).</p>		

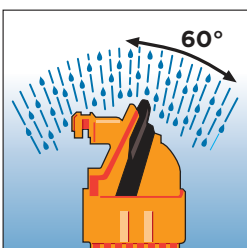
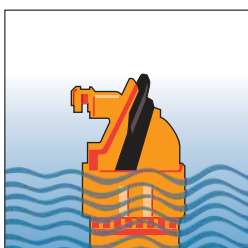
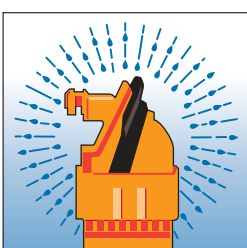
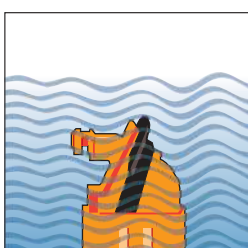
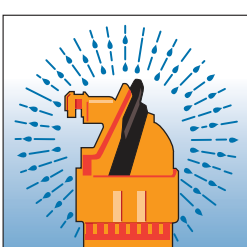
IP Code (Elements and Significance acc. to IEC 60529 and DIN 40050)

2nd Digit	Against Water	2nd Digit	Against Water
0	 <p>Not protected.</p>	5	 <p>Protected against jetting water.</p>
1	 <p>Protected against vertically dripping water.</p>	6	 <p>Protected against powerfully jetting water.</p>
2	 <p>Protected against dripping water when tilted up to 15°.</p>	6K	 <p>Protected against powerfully jetting water with increased pressure (Automotive).</p>
3	 <p>Protected against spraying water (up to 60° inclination).</p>	7	 <p>Protected against the temporary effects of immersion up to 1 meter.</p>
4	 <p>Protected against splashing water.</p>	8	 <p>Protected against continuous submersion agreed with customer, but more severe than code 7.</p>
4K	 <p>Protected against splashing water with increased pressure.</p>	9K	 <p>Protected against high-pressure/steam-jet cleaning (Automotive).</p>

Page

AMP MCP Interconnection System		
Introduction	3-1	✓
Contact Systems		
Introduction	3-3	✓
AMP MCP 1.5K Receptacle Contacts (for 0.6 mm Tab Thickness)	3-4	✓
AMP MCP 1.5K Receptacle Contacts (for 0.8 mm Tab Thickness)	3-5	✓
AMP MCP 1.5K Tab Contacts	3-6-3-7	✓
AMP MCP 1.5K Single Wire Seals and Sealing Plugs	3-8	✓
AMP MCP 2.8 Receptacle Contacts	3-9	✓
AMP MCP 2.8 Lanceless Receptacle Contacts	3-10	✓
AMP MCP 2.8K Receptacle Contacts	3-11	✓
AMP MCP 2.8 Tab Contacts	3-12	✓
AMP MCP 2.8K Tab Contacts	3-13	✓
AMP MCP 2.8 Single Wire Seals and Sealing Plugs	3-14	✓
AMP MCP 2.8K Single Wire Seals and Sealing Plugs	3-15	✓
AMP MCP 6.3/4.8K Receptacle Contacts	3-17	✓
AMP MCP 6.3/4.8K Tab Contacts	3-18-3-19	✓
AMP MCP 6.3/4.8K Single Wire Seals and Sealing Plugs	3-20-3-21	✓
AMP MCP 9.5 Lanceless Receptacle Contacts	3-23	✓
AMP MCP 9.5 Receptacle Contacts	3-24	✓
AMP MCP 9.5 Tab Contacts	3-25	✓
AMP MCP 9.5 Single Wire Seals and Sealing Plugs	3-26	✓

THE PRODUCTS



✓	✓	✓	✓
✓	✓	✓	✓
✓	✓	✓	✓
✓	✓	✓	✓
✓	✓	✓	✓
✓	✓	✓	✓
✓	✓	✓	✓
✓	✓	✓	✓
✓	✓	✓	✓
✓	✓	✓	✓
✓	✓	✓	✓
✓	✓	✓	✓
✓	✓	✓	✓
✓	✓	✓	✓
✓	✓	✓	✓
✓	✓	✓	✓
✓	✓	✓	✓
✓	✓	✓	✓
✓	✓	✓	✓
✓	✓	✓	✓
✓	✓	✓	✓
✓	✓	✓	✓



Page

Unsealed Housings and Connectors		
Introduction	3-27	✓
Unsealed AMP MCP 1.5K Receptacle Housings	3-28–3-31	✓
Unsealed AMP MCP 1.5K/2.8 Receptacle Housings	3-32–3-33	✓
Unsealed AMP MCP 1.5K Receptacle Insert	3-34–3-35	✓
Unsealed AMP MCP 2.8 Receptacle Insert	3-36	✓
Unsealed (Carrier) Housings for AMP MCP 1.5K Receptacle Inserts	3-37	✓
Unsealed (Carrier) Housings for AMP MCP 1.5K/2.8 Receptacle Inserts	3-38	✓
Unsealed AMP MCP 2.8 Receptacle Housings with Secondary Locking	3-39–3-41	✓
Unsealed AMP MCP 2.8 Receptacle Housings	3-42	✓
Unsealed AMP MCP 6.3 Receptacle Housings with Secondary Locking	3-43	✓
Unsealed AMP MCP 9.5 Receptacle Housings with Secondary Locking	3-44	✓
Unsealed 1.5 mm/2.8 mm Tab Housings	3-45–3-47	✓
Unsealed 1.5 mm Tab Housings	3-48	✓
Unsealed 2.8 mm Tab Housings with Optional Secondary Locking	3-49	✓
Unsealed 2.8 mm Tab Housings for Potential Distribution	3-50–3-51	✓
Unsealed 9.5 mm Tab Housings with Secondary Locking	3-52	✓
Unsealed 1.5 mm Housings – PCB Headers	3-53–3-54	✓
Unsealed 2.8 mm Housings – Vertical PCB Headers	3-55	✓
Unsealed 2.8 mm Housings – PCB Headers	3-56	✓
Sealed Housings and Connectors		
Sealed AMP MCP 1.5K/2.8 Receptacle Housings	3-57–3-58	✓
Sealed AMP MCP 2.8 Receptacle Housings	3-59–3-65	✓
Sealed AMP MCP 9.5 Receptacle Housings	3-66–3-67	✓
Sealed 1.5 mm/2.8 mm Tab Housings	3-69–3-71	✓
Sealed 2.8 mm Tab Housings	3-72	✓
Sealed 9.5 mm Tab Housings	3-73–3-74	✓

THE PRODUCTS



✓	✓	✓	✓
✓	✓	✓	✓
✓	✓	✓	✓
✓	✓	✓	✓
✓	✓	✓	✓
✓	✓	✓	✓
✓	✓	✓	✓
✓	✓	✓	✓
✓	✓	✓	✓
✓	✓	✓	✓
✓	✓	✓	✓
✓	✓	✓	✓
✓	✓	✓	✓
✓	✓	✓	✓
✓	✓	✓	✓
✓	✓	✓	✓
✓	✓	✓	✓
✓	✓	✓	✓
✓	✓	✓	✓
✓	✓	✓	✓
✓	✓	✓	✓
✓	✓	✓	✓
✓	✓	✓	✓
✓	✓	✓	✓
✓	✓	✓	✓
✓	✓	✓	✓
✓	✓	✓	✓



Page

Heavy Duty Sealed 2.8 Lamp Connector		
Introduction	3-75	✓
Sealed Receptacle Housings	3-76–3-77	✓
Sealed Tab Housings	3-78–3-79	✓
Accessories	3-80	✓
Heavy Duty Sealed Connector Series (HDSCS)	3-81	✓
LEAVYSEAL Connector Series		
Introduction	3-83	✓
Sealed AMP MCP 2.8 Receptacle Housings	3-84	✓
Sealed AMP MCP 1.5K/2.8 Receptacle Housings	3-85	✓
Sealed AMP MCP 2.8 Receptacle Housings	3-86	✓
Sealed AMP MCP 1.5K/2.8/6.3 Receptacle Housings	3-87–3-88	✓
Sealed AMP MCP 1.5K Receptacle Housings	3-89	✓
Sealed AMP MCP 1.5K/2.8 Receptacle Housings	3-90	✓
Sealed AMP MCP 2.8 Receptacle Housings	3-91	✓
Sealed AMP MCP 2.8/6.3 Receptacle Housings	3-92	✓
Sealed AMP MCP 1.5K Receptacle Housings	3-93	✓
Sealed 2.8 mm Tab Housings	3-95	✓
Sealed 1.5 mm/2.8 mm Tab Housings	3-96	✓
Sealed 2.8 mm Tab Housings	3-97	✓
Sealed 1.5 mm/2.8 mm/6.3 mm Tab Housings	3-98	✓
Sealed 1.5 mm/2.8 mm Tab Housings	3-99	✓
Sealed 2.8 mm Tab Housings	3-100	✓
Sealed 2.8 mm Tab Housings - PCB Headers	3-101–3-102	✓
Sealed 1.5 mm/2.8 mm Tab Housings - PCB Headers	3-103	✓
Sealed 1.5 mm Tab Housings - PCB Headers	3-104	✓

THE PRODUCTS



✓	✓	✓	✓
✓	✓	✓	✓
✓	✓	✓	✓
✓	✓	✓	✓
✓			✓
✓			✓
✓			✓
✓			✓
✓			✓
✓			✓
✓			✓
✓			✓
✓			✓
✓			✓
✓			✓
✓			✓
✓			✓
✓			✓
✓			✓
✓			✓
✓			✓
✓			✓
✓			✓

Page

Application Tooling and Equipment		
Introduction	3-105	✓
Insertion Machines for Single Contacts	3-106–3-108	✓
IDC Machines	3-109	✓
Lead Makers	3-110–3-117	✓
Applicators	3-118–3-120	✓
Crimping Presses and Accessories	3-121–3-131	✓
Resistance Welding Equipment	3-132	✓
MOST™ Equipment	3-133–3-134	✓
Hand Tools	3-135–3-139	✓
FFC-FPC Equipment	3-140–3-141	✓
Magnet Wire Equipment	3-142–3-143	✓
Board Processing Equipment	3-144–3-147	✓
Equipment for Electrical Testing	3-148	✓
Application Tooling Global Field Service Organization	3-149	✓
Application Tooling Americas Field Service Locations	3-150	✓
Application Tooling EMEA Field Service Locations	3-151	✓
Application Tooling Asia Pacific Field Service Locations	3-152	✓
Numerical Index	3-153–3-157	✓
Disclaimer and Trademarks	3-158	✓



THE PRODUCTS



✓	✓	✓	✓
✓	✓	✓	✓
✓	✓	✓	✓
✓	✓	✓	✓
✓	✓	✓	✓
✓	✓	✓	✓
✓	✓	✓	✓
✓	✓	✓	✓
✓	✓	✓	✓
✓	✓	✓	✓
✓	✓	✓	✓
✓	✓	✓	✓
✓	✓	✓	✓
✓	✓	✓	✓
✓	✓	✓	✓
✓	✓	✓	✓
✓	✓	✓	✓
✓	✓	✓	✓
✓	✓	✓	✓
✓	✓	✓	✓
✓	✓	✓	✓
✓	✓	✓	✓
✓	✓	✓	✓
✓	✓	✓	✓
✓	✓	✓	✓
✓	✓	✓	✓

Engineering Notes

A large grid of graph paper for engineering notes, consisting of a uniform pattern of small squares covering the majority of the page.

Introduction



AMP MCP offers High Reliability for Long Term Use



The AMP MCP (Multiple Contact Point) Connector System is designed for electronic and electrical applications in motor vehicles.

It fulfills all requirements for a connector system for use in automobiles and covers a wide range of applications.

AMP MCP Contacts

- Basic material (CuNiSi) with high current capacity
- 3 redundant contact points (1.5 mm type), 4 contact points (2.8 mm/6.3 mm type), 6 contact points (9.5 mm type)
- Good guiding inside the cavity
- Protected contact spring due to the closed box
- Overstress protection of the contact springs
- Steel box with secondary locking possibility from four sides
- Protected locking lance

AMP MCP Connectors

- High reliability status supported for long term use
- High vibration level supported
- Perfect design to avoid quality problems, reduce manufacturing and service cost
- Integrated secondary locking device delivered in pre-locked position
- Wire-to-wire sealed and unsealed connectors (SWS)
- Wire-to-board sealed and unsealed connectors (SWS)
- Polarisation, several keyings
- Locking mechanism for smaller connectors/mating aid for higher numbers of ways

Engineering Notes

A large grid of graph paper for engineering notes, consisting of a uniform pattern of small squares covering the majority of the page.

Introduction



The AMP MCP Contact System is mainly used in the automotive industry. Each contact consists of a flat receptacle, which mates with a flat tab. Every contact has got a steel spring and a copper alloy body.

The two-piece contact design means that the electrical and mechanical properties are separated. One end of the contact body is crimped to wire and the other end mates with the matching tab. The closed spring has got several functions and also different advantages for the complete contact system.

- Protection of the contact springs
- No over elongation of the contact springs possible under normal circumstances
- No possibility to connect from the rear side
- Protection against mechanical damage
- Good guiding in the cavity
- Secondary locking possible (from 4 directions)
- Assembly into housing fully-automatically

In addition there are usually two lances on the steel to spring. These serve to lock the contact securely in the housing.

The Main Advantages of the Body are:

- Several contact points
- Large range of wire sizes (from 0.2 mm² at AMP MCP 1.5K up to 16.0 mm² at AMP MCP 9.5)
- Base material with very high current capability
- High vibrational load

Tabs and receptacles can be applied in both sealed and unsealed connectors.

AMP MCP contacts can be fast and economically arranged to the lead using TE Connectivity application tooling.

Receptacle Contacts (for 0.6 mm Tab Thickness)

Technical Features

Contact Material:

CuNiSi
Top Spring: Stainless Steel

Contact Finish:

Tin plated, selective silver plated,
selective gold plated

Wire Size Range:

0.20–0.35 mm², 0.5–1.0 mm²,
>1.0–1.5 mm² (FLR Cable)

Current Carrying Capacity:

up to 20 Ampere
(at 20 °C ambient temperature)

Temperature Range:

–40 °C ... +130 °C (tin plated)
–40 °C ... +140 °C (silver plated)
–40 °C ... +150 °C (gold plated)

Modular Dimensions (Centerline):

0.2–1.5 mm² SRC:
– 4.0 x 4.0 mm
– 4.0 x 3.5 mm (Staggered)

0.2–1.5 mm² SWS:
– 4.0 x 4.0 mm
– 4.0 x 3.5 mm (Staggered)

Mating Cycles: ●

up to 10 cycles (tin plated)
up to 50 cycles (silver plated)
up to 100 cycles (gold plated)

Mating Force: Max. 6 N

Unmating Force: Max. 6 N

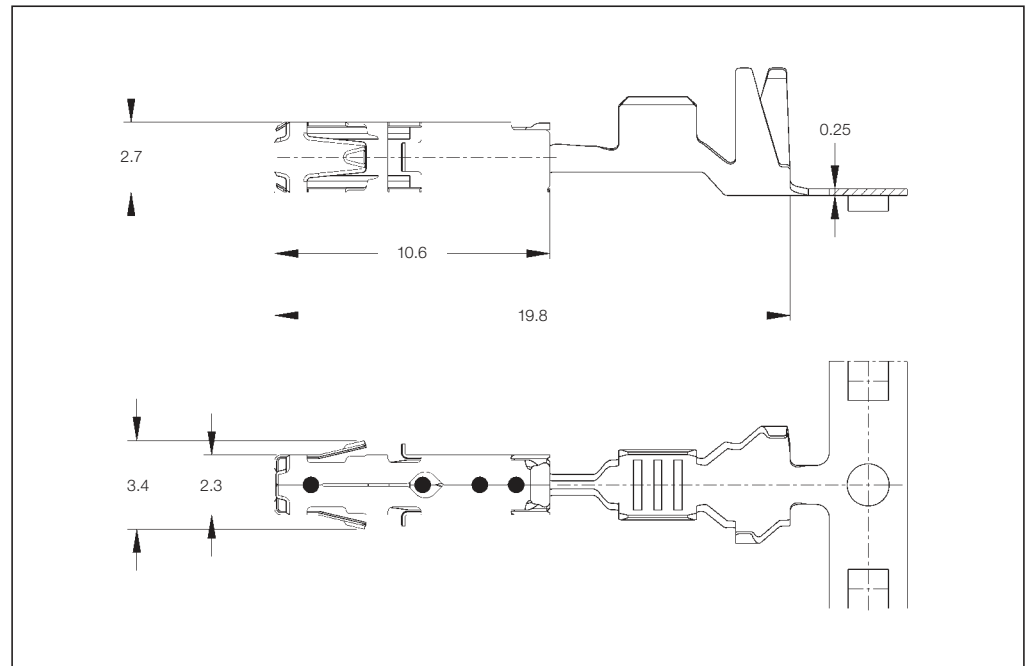

Contact Resistance:

New State ≤ 2 mΩ

Dimension of Male Contacts:

1.5^{+0.2}_{-0.1} x 0.6^{+0.07}_{-0.03} mm

Extraction Tool:

Part No. **1-1579007-1**

Product Group Drawing:

1241436

Product Specification:

108-18716

Application Specification:

114-18386

●) The maximum number of mating cycles is dependent on the tribological properties of the used surfaces in each case. Only by using the relevant/matching surfaces and contact geometries, receptacle and tab contacts produced and delivered by TE Automotive, the maximum number of insertions can be achieved.

Standard Receptacle Contacts (SRC)

Wire Size Range (mm ²)	Insulation Diameter (mm)		Material and Finish *	Part Numbers					
	FLK	FLR		Strip Form	Package Quantity	Loose-Piece	Package Quantity	Applicator ♦	Hand Tool
0.20–0.35	–	1.1–1.4	-1 / -2	1564980	10,000	1564981	500	x-1530216-x	4-1579016-0
		1.4–2.1		1241372***	10,000	1241373	500	x-1528194-x	
0.5–1.0	–	max. 2 x 1.6	-1 / -2	1241374	8,000	1241375	500	x-1528195-x	539950-2
				1241376**	6,000	1241377**	500	x-1528388-x	
>1.0–1.5	–	2.2–2.4	-1	1534334	7,500	1534335	500	x-1528312-x	5-1579001-3

Receptacle Contacts Single Wire Sealing System (SWS)

Wire Size Range (mm ²)	Insulation Diameter (mm)		Material and Finish *	Part Numbers					
	FLK	FLR		Strip Form	Package Quantity	Loose-Piece	Package Quantity	Applicator ♦	Hand Tool
0.20–0.35	–	1.1–1.4	-1 / -2	1564324	4,500	1564325	500	x-1528897-x	4-1579016-0
				1241378***	4,500	1241379	500	x-1528122-x	539950-2
0.5–1.0	–	1.4–2.1	-1 / -2 / -3 / 1-xxx-2	1241380	4,500	1241381	500	x-1528324-x	
>1.0–1.5	–	2.2–2.4	-1 / -3	1418884	4,500	1418885	500	x-1530008-x	5-1579001-3

***) Material and Finish:**

xxx-1 = CuNiSi, pre-tin plated
xxx-2 = CuNiSi, selective gold plated
xxx-3 = CuNiSi, selective silver plated
1-xxx-2 = CuNiSi, min. 1.27 µm selective gold plated

*****) Double Crimp**

♦) The pre- and suffix for the applicators depends on the applied termination equipment.

*****) Part No. 1241372 is replaced by Part No. 1564980.**

Part No. 1241372 not for new application.
Part No. 1241378 is replaced by Part No. 1564324.
Part No. 1241378 not for new application.

Receptacle Contacts (for 0.8 mm Tab Thickness)

Technical Features

Contact Material:

CuNiSi
Top Spring: Stainless Steel

Contact Finish:

Tin plated, selective silver plated,
selective gold plated

Wire Size Range:

0.20–0.35 mm², 0.5–1.0 mm²,
>1.0–1.5 mm² (FLR Cable)

Current Carrying Capacity:

up to 20 Ampere
(at 20 °C ambient temperature)

Temperature Range:

–40 °C ... +130 °C (tin plated)
–40 °C ... +140 °C (silver plated)
–40 °C ... +150 °C (gold plated)

Modular Dimensions (Centerline):

0.2–1.5 mm² SRC:

– 4.0 x 4.0 mm
– 4.0 x 3.5 mm (Staggered)

0.2–1.5 mm² SWS:

– 4.0 x 4.0 mm
– 4.0 x 3.5 mm (Staggered)

Mating Cycles: ♦

up to 10 cycles (tin plated)
up to 50 cycles (silver plated)
up to 100 cycles (gold plated)

Mating Force: Max. 6 N

Unmating Force: Max. 6 N

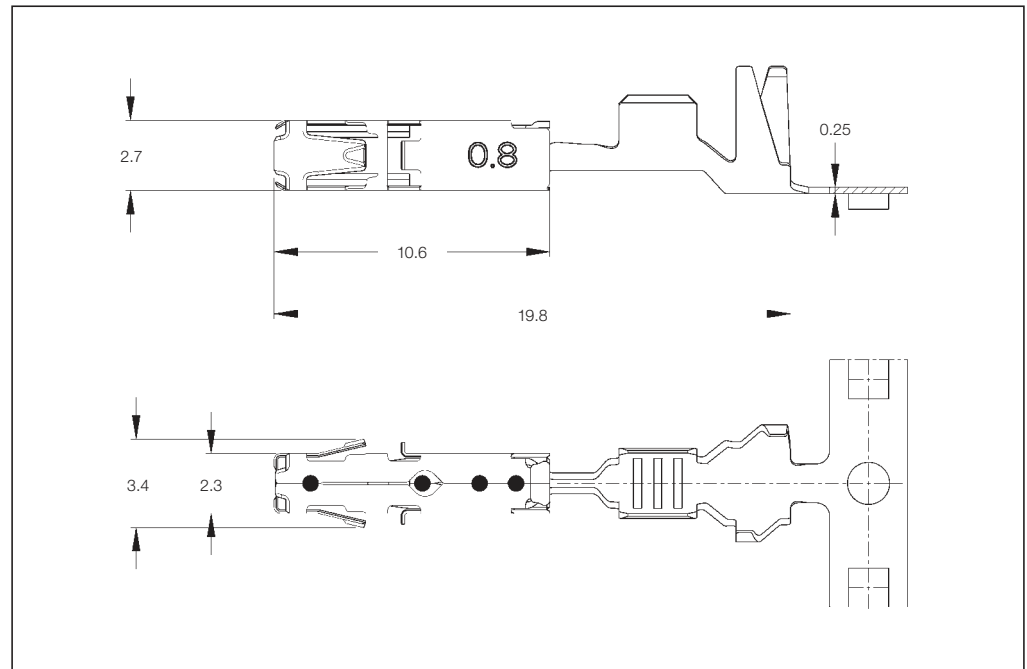

Contact Resistance:

New State ≤ 2 mΩ

Dimension of Male Contacts:

1.5^{+0.2}_{-0.1} x 0.8^{±0.03} mm

Extraction Tool:

Part No. **1-1579007-1**

Product Group Drawing:

1241436

Product Specification:

108-18716

Application Specification:

114-18386

♦) The maximum number of mating cycles is dependent on the tribological properties of the used surfaces in each case. Only by using the relevant/matching surfaces and contact geometries, receptacle and tab contacts produced and delivered by TE Automotive, the maximum number of insertions can be achieved.

Standard Receptacle Contacts (SRC)

Wire Size Range (mm ²)	Insulation Diameter (mm)		Material and Finish*	Part Numbers					
	FLK	FLR		Strip Form	Package Quantity	Loose-Piece	Package Quantity	Applicator ♦	Hand Tool
0.5–1.0	–	1.4–2.1	-1	1418408	8,000	1418409	500	x-1528195-x	539950-2
>1.0–1.5	–	2.2–2.4	-1	1418410	7,500	1418411	500	x-1528312-x	5-1579001-3

Receptacle Contacts Single Wire Sealing System (SWS)

Wire Size Range (mm ²)	Insulation Diameter (mm)		Material and Finish*	Part Numbers					
	FLK	FLR		Strip Form	Package Quantity	Loose-Piece	Package Quantity	Applicator ♦	Hand Tool
0.20–0.35	–	1.1–1.4	-1	1534160	4,500	1534161	500	x-1528122-x	539950-2
0.5–1.0	–	1.4–2.1	-1	1534162	4,500	1534163	500	x-1528324-x	
>1.0–1.5	–	2.2–2.4	-1	1718558	4,500	1718559	500	x-1530008-x	5-1579001-3

***) Material and Finish:**

xxx-1 = CuNiSi, pre-tin plated
xxx-2 = CuNiSi, selective gold plated
xxx-3 = CuNiSi, selective silver plated
1-xxx-2 = CuNiSi, min. 1.27 µm selective gold plated

♦) The pre- and suffix for the applicators depends on the applied termination equipment.

Tab Contacts

**Tabs 1.6 x 0.6 mm
with Steel Top Spring,
Mates with
AMP MCP 1.5K
Contact System**

Product Specification:
108-18331

Application Specification:
114-18082

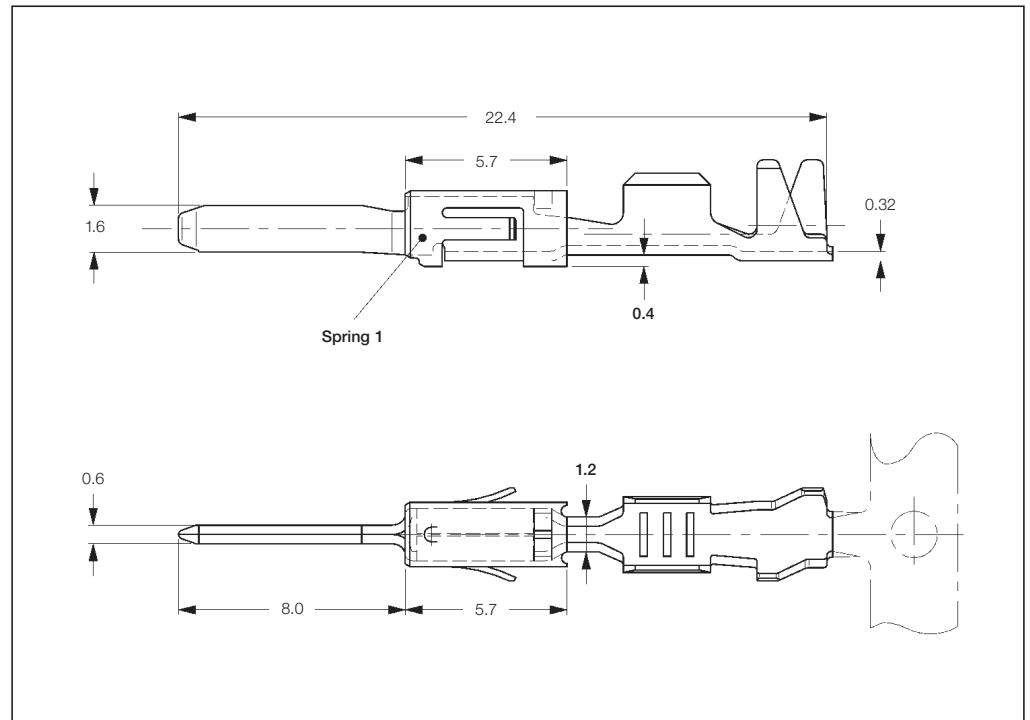

Standard Tab Contacts (STC)

Wire Size Range (mm ²)	Insulation Diameter (mm)		Material and Finish*	Part Numbers					
	FLK	FLR		Strip Form	Package Quantity	Loose-Piece	Package Quantity	Applicator*	Hand Tool
0.2-0.5	-	1.15-1.60	-1 / -2 / -3	963898 1)	7,000	963899 1)	500	x-1528061-x	2063265-1
0.5-1.0	-	1.4-2.1	-1 / -2 / -3	963900 1)	6,000	963901 1)	500	x-1528256-x	

Tab Contacts Single Wire Sealing System (SWS)

Wire Size Range (mm ²)	Insulation Diameter (mm)		Material and Finish*	Part Numbers					
	FLK	FLR		Strip Form	Package Quantity	Loose-Piece	Package Quantity	Applicator*	Hand Tool
0.2-0.5	-	1.15-1.60	-1 / -2 / -3	963902 1)	4,000	963903 1)	500	x-1528281-x	2063265-1
0.5-1.0	-	1.4-2.1	-1 / -2 / -3	963904 1)	4,000	963905 1)	500	x-1528054-x	

***) Material and Finish:**
xxx-1 = CuSn4, pre-tin plated
xxx-2 = CuFe2, pre-tin plated
xxx-3 = CuSn4, gold plated

Remarks:
1) = With Spring 1

*) The pre- and suffix for the applicators depends on the applied termination equipment.

Tab Contacts

Tabs 1.6 x 0.6 mm with Modified Steel Top Spring, Mates with AMP MCP 1.5K Contact System

Extraction Tool:
Part No. **539960-1**

Product Group Drawing:
1355055

Product Specification:
108-18331

Application Specification:
114-18082

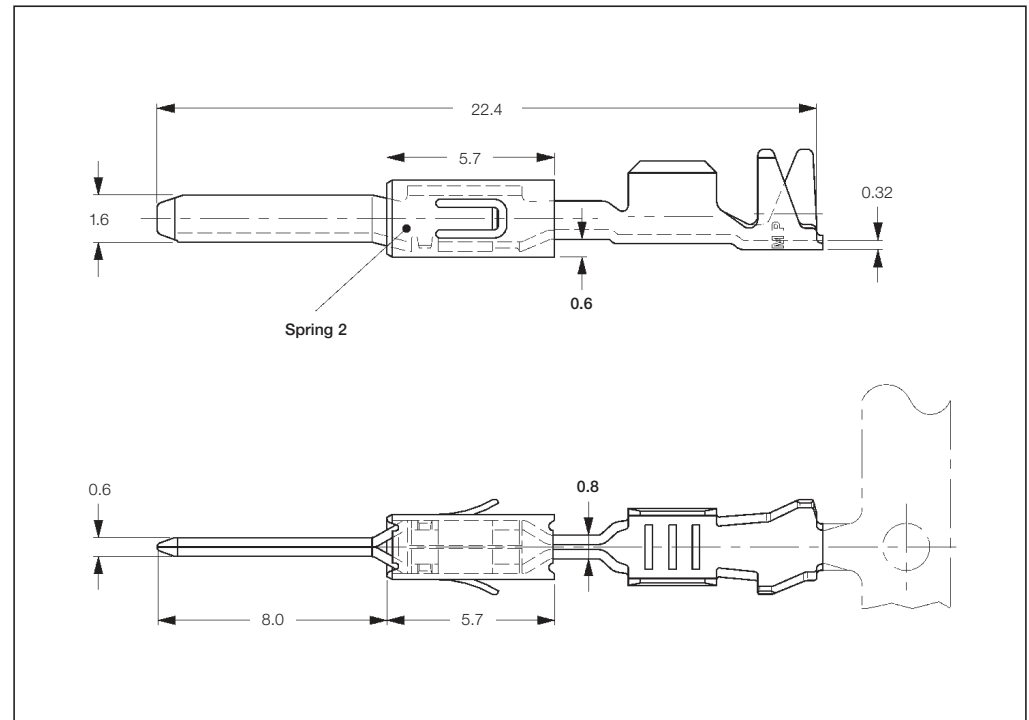

Standard Tab Contacts with Modified Spring (STC)

Wire Size Range (mm ²)	Insulation Diameter (mm)		Material and Finish *	Part Numbers					
	FLK	FLR		Strip Form	Package Quantity	Loose-Piece	Package Quantity	Applicator ♦	Hand Tool
0.2-0.5	-	1.15-1.60	-2 / -3	964265 ²⁾	7,500	964266 ²⁾	500	x-1528091-x	
0.5-1.0	-	1.4-2.1	-2 / -3	969079 ^{2) 3)}	5,500	969080 ^{2) 3)}	500	x-1528096-x	2063409-1
0.5-1.0	-	1.4-2.1	-1 / -2 / -3	964267 ²⁾	6,000	964268 ²⁾	500	x-1528092-x	
1.5	-	2.2-2.4	-1 / -2 / -3	1241846 ²⁾	4,000	1241847 ²⁾	500	x-1528123-x	-

Tab Contacts Single Wire Sealing System with Modified Spring (SWS)

Wire Size Range (mm ²)	Insulation Diameter (mm)		Material and Finish *	Part Numbers					
	FLK	FLR		Strip Form	Package Quantity	Loose-Piece	Package Quantity	Applicator ♦	Hand Tool
0.2-0.5	-	1.2-1.6	-2 / -3	969028 ²⁾	4,000	969029 ²⁾	500	x-1528068-x	
0.5-1.0	-	1.4-2.1	-2 / -3	964269 ²⁾	4,000	964270 ²⁾	500	x-1528261-x	539663-2
1.5	-	1.9-2.4	-2 / -5	1703278	4,000	1703279	500	x-1528579-x	-

***) Material and Finish:**
xxx-1 = CuSn4, pre-tin plated
xxx-2 = CuFe2, pre-tin plated
xxx-3 = CuSn4, gold plated
xxx-5 = CuSn4, selective silver plated

Remarks:
2) = With Spring 1 (shown on Page 3-6) or Spring 2
3) = For Double and Single Termination

♦) The pre- and suffix for the applicators depends on the applied termination equipment.

Single Wire Seals and Sealing Plugs

Single Wire Seals and Sealing Plugs for AMP MCP 1.5K Contact System (Cavity Diameter 3.6 mm)

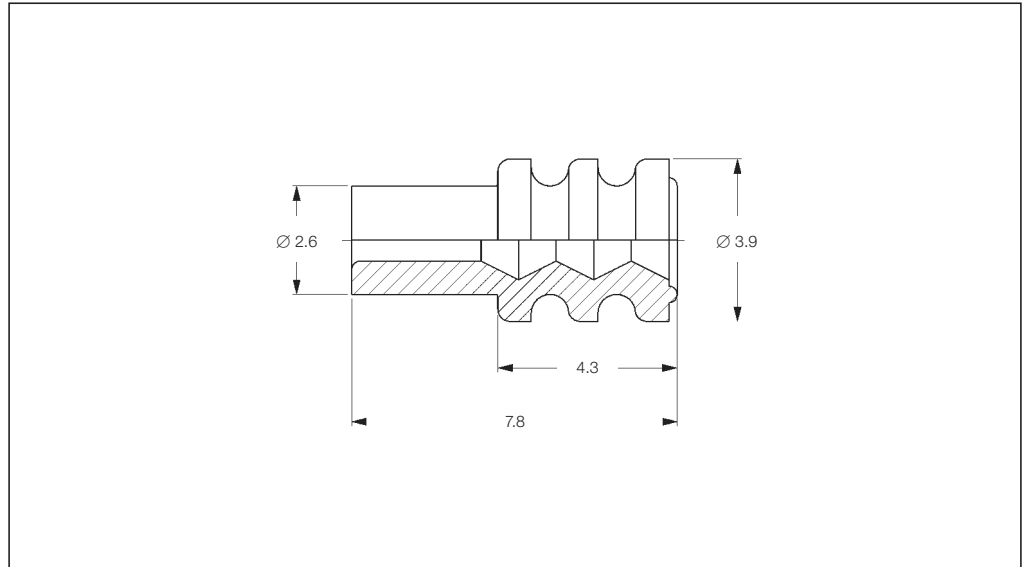

Insulation Diameter (mm)	Color	Part Number	Package Quantity
0.9-1.2	Green	1718705-1	10,000
1.2-1.6	Red	964971-1	10,000
	Blue	1394133-1	10,000
1.4-1.9	Gray	963530-1	10,000
1.9-2.4*	Yellow	964972-1	10,000
1.9-2.4**	Orange	2112323-1	20,000
Sealing Plug	White	963531-1	10,000
	Natural	1394132-1	10,000

*) Fits to Part No. **1418885** and Part No. **1718558**
) Fits to Part No. **1703278

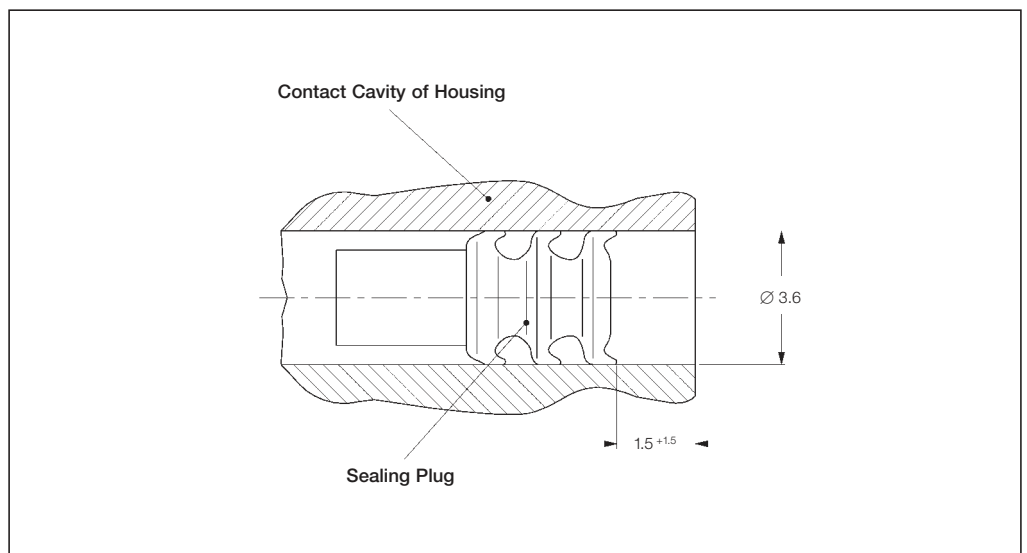

Receptacle Contacts

Technical Features

Material:

Contact: CuNiSi
Tabs: CuSn4, CuFe2
Top Spring: Stainless Steel

Contact Finish:

Tin plated, selective silver plated,
selective gold plated

Wire Size Range:

0.2–0.5 mm², 0.5–1.0 mm²,
1.0–2.5 mm², 2.5–4.0 mm²
Single Wires (FLR)

Current Carrying Capacity:

up to 40 Ampere
(at 20 °C ambient temperature)

Mating Force*: Max. 6 N

Unmating Force*: Max. 5 N

Modular Dimensions (Centerline)

0.2–2.5 mm² SRC:

– 5.0 x 5.5 mm
– 5.0 x 5.0 mm (Staggered)

2.5–4.0 mm² SRC:

– 5.5 x 5.5 mm
– 5.0 x 5.5 mm (Staggered)

2.5–4.0 mm² SWS:

– 7.2 x 7.2 mm
– 6.0 x 7.2 mm (Staggered)

Dimension of Male Contacts:

2.8 ±0.1 x 0.8 ±0.03 mm
3.0 ±0.1 x 0.8 ±0.03 mm

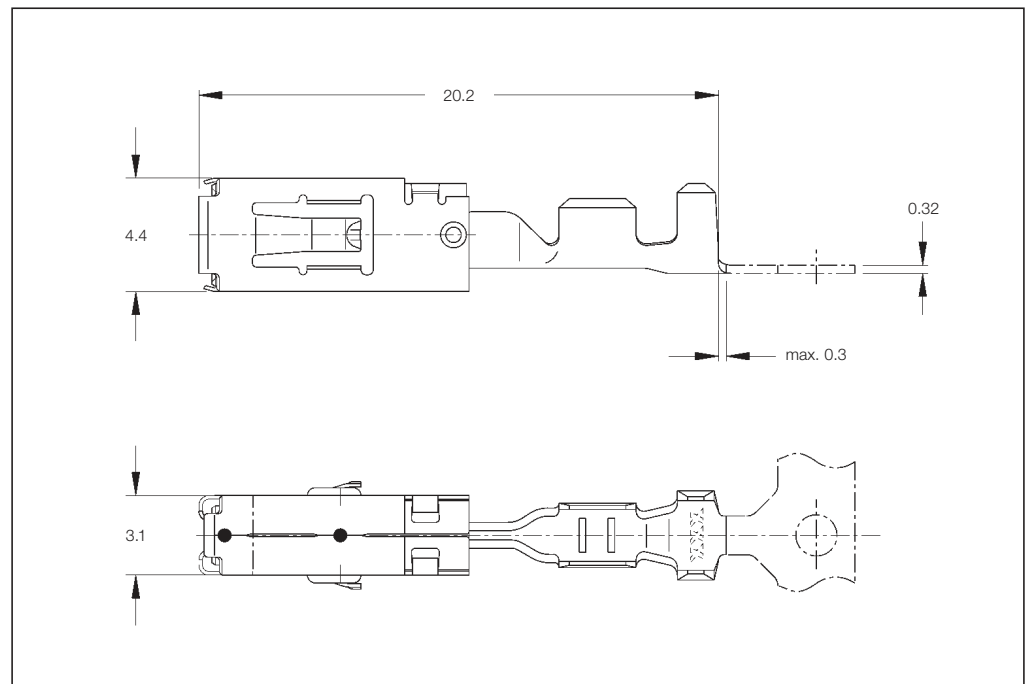

Mating Cycles:●

up to 10 cycles (tin plated)
up to 50 cycles (silver plated)
up to 100 cycles (gold plated)

Temperature Range:

–40 °C ... +130 °C (tin plated)
–40 °C ... +140 °C (silver plated)
–40 °C ... +150 °C (gold plated)

Product Specification:

108-18513

Application Specification:

114-18148

Contact Resistance:

New State ≤ 2 mΩ

Extraction Tool:

Part No. **1-1579007-2**

Product Group Drawing:

1355036

*) Steel Tab, see Specifications

●) The maximum number of mating cycles is dependent on the tribological properties of the used surfaces in each case. Only by using the relevant/matching surfaces and contact geometries, receptacle and tab contacts produced and delivered by TE Automotive, the maximum number of insertions can be achieved.

Standard Receptacle Contacts (SRC)

Wire Size Range (mm ²)	Insulation Diameter (mm)		Material and Finish*	Part Numbers					
	FLK	FLR		Strip Form	Package Quantity	Loose-Piece	Package Quantity	Applicator ♦	Hand Tool Complete
0.2–0.5	–	1.2–1.4	1-xxx-1 / 1-xxx-3	968880	4,500	968895	500	x-1528381-x	539721-2
0.5–1.0	–	1.4–2.1	1-xxx-1 / 1-xxx-2 / 1-xxx-3	968849	4,500	968872	500	x-1528115-x	539722-2
1.0–2.5	–	2.2–3.0	1-xxx-1 / 1-xxx-2 / 1-xxx-3	968851	3,500	968873	500	x-1528033-x	539723-2
2.5–4.0	–	3.0–3.7	1-xxx-1 / 1-xxx-3	968853	2,700	968874	500	x-1528430-x	

Receptacle Contacts Single Wire Sealing System (SWS)

Wire Size Range (mm ²)	Insulation Diameter (mm)		Material and Finish*	Part Numbers					
	FLK	FLR		Strip Form	Package Quantity	Loose-Piece	Package Quantity	Applicator ♦	Hand Tool Complete
0.35–0.50	–	1.2–1.4	1-xxx-1 / 1-xxx-3	968882	4,500	968896	500	x-1426162-x	539725-2
0.5–1.0	–	1.4–2.1	1-xxx-1 / 1-xxx-2 / 1-xxx-3	968855	3,500	968875	500	x-1528017-x	539726-2
1.0–2.5	–	2.2–3.0	1-xxx-1 / 1-xxx-3	968857	4,000	968876	500	x-1528066-x	539727-2
2.5–4.0	–	3.0–3.7	1-xxx-1 / 1-xxx-3	968859	2,500	968877	500	x-1528067-x	

*) **Material and Finish:**
1-xxx-1 = CuNiSi, pre-tin plated
1-xxx-2 = CuNiSi, selective gold plated
1-xxx-3 = CuNiSi, selective silver plated

♦) The pre- and suffix for the applicators depends on the applied termination equipment.

Lanceless Receptacle Contacts

Technical Features

Material:

Contact: CuNiSi
Tab: CuSn4, CuFe2
Top Spring: Stainless Steel

Contact Finish:

Tin plated

Wire Size Range:

0.2–0.5 mm², >0.5–1.0 mm²,
>1.0–2.5 mm², >2.5–4.0 mm²
Single Wires (FLR)

Current Carrying Capacity:

up to 40 Ampere
(at 20 °C ambient temperature)

Temperature Range:

–40 °C ... +130 °C (tin plated)
–40 °C ... +140 °C (silver plated)
–40 °C ... +150 °C (gold plated)

Modular Dimensions

(Centerline):

0.2–2.5 mm² SRC:
– 5.0 x 5.5 mm
– 5.0 x 5.0 mm (Staggered)
2.5–4.0 mm² SRC:
– 5.5 x 5.5 mm
– 5.0 x 5.5 mm (Staggered)

Mating Force*:

Max. 6 N

Unmating Force*:

Max. 5 N

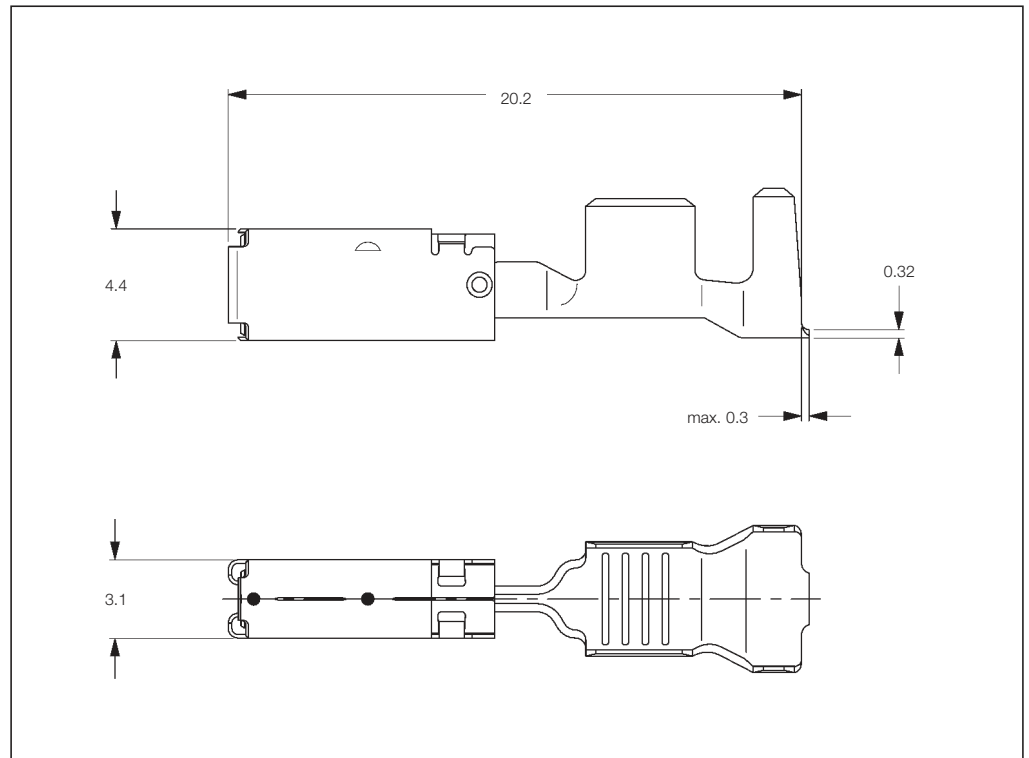

Mating Cycles:•

up to 10 cycles (tin plated)
up to 50 cycles (silver plated)
up to 100 cycles (gold plated)

Contact Resistance:

New State ≤ 2 mΩ

Dimension of Male Contacts:

2.8 ± 0.1 x 0.8 ± 0.03 mm
3.0 ± 0.1 x 0.8 ± 0.03 mm

Extraction Tool:

Extraction possible without tool

Product Specification:

108-18513

Application Specification:

114-18148

Product Group Drawing:

1719458

*) Steel Tab, see Specifications

•) The maximum number of mating cycles is dependent on the tribological properties of the used surfaces in each case. Only by using the relevant/matching surfaces and contact geometries, receptacle and tab contacts produced and delivered by TE Automotive, the maximum number of insertions can be achieved.

Lanceless Receptacle Contacts

Wire Size Range (mm ²)	Insulation Diameter (mm)		Material and Finish*	Part Numbers					
	FLK	FLR		Strip Form	Package Quantity	Loose-Piece	Package Quantity	Applicator	Hand Tool
0.2–0.5	–	1.2–1.4	1-xxx-1	1355876	4,500	–	–	x-1528381-x	539721-2
>0.5–1.0	–	1.4–2.1	1-xxx-1	1355833	4,500	–	–	x-1528115-x	539722-2
>1.0–2.5	–	2.2–3.0	1-xxx-1	1355877	3,500	–	–	x-1528033-x	539723-2
>2.5–4.0	–	3.0–3.7	1-xxx-1	1355880	2,700	–	–	x-1528430-x	

***) Material and Finish:**

1-xxx-1 = CuNiSi, pre-tin plated

Receptacle Contacts

Technical Features

Contact Material:

CuNiSi
Top Spring: Stainless Steel

Contact Finish:

Tin plated, selective silver plated,
selective gold plated

Wire Size Range:

0.20–0.35 mm², 0.5–1.0 mm²,
>1.0–2.5 mm² (FLR Cable)

Current Carrying Capacity:

up to 34 Ampere
(at 20 °C ambient temperature)

Temperature Range:

–40 °C ... +130 °C (tin plated)
–40 °C ... +140 °C (silver plated)
–40 °C ... +150 °C (gold plated)

Modular Dimensions (Centerline):

0.2–2.5 mm² SRC:

– 5.0 x 5.5 mm
– 5.0 x 5.0 mm (Staggered)

0.35–2.5 mm² SWS:

– 6.0 x 6.0 mm
– 5.0 x 5.5 mm (Staggered)

Mating Cycles: ●

up to 10 cycles (tin plated)
up to 50 cycles (silver plated)
up to 100 cycles (gold plated)

-) The maximum number of mating cycles is dependent on the tribological properties of the used surfaces in each case. Only by using the relevant/matching surfaces and contact geometries, receptacle and tab contacts produced and delivered by TE Automotive, the maximum number of insertions can be achieved.

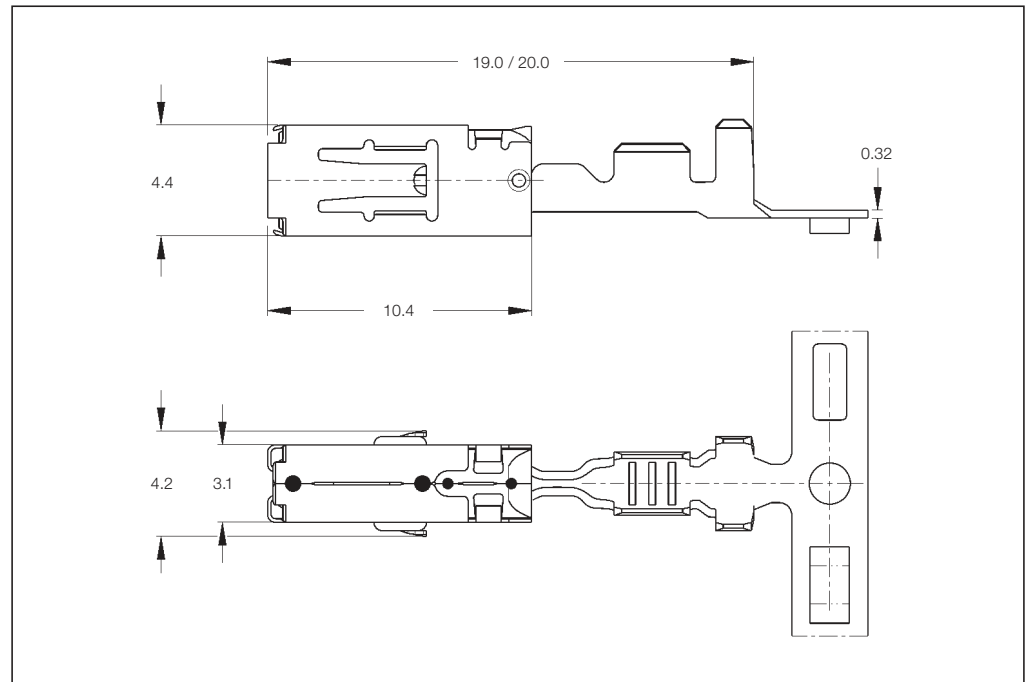

Contact Resistance:

New State ≤ 2 mΩ

Mating Force: Max. 10 N

Unmating Force: Max. 7 N

Dimension of Male Contacts:

2.8 ± 0.1 x 0.8 ± 0.03 mm

2.8 ± 0.1 x 0.6 ± 0.03 mm

3.0 ± 0.1 x 0.8 ± 0.03 mm

3.0 ± 0.1 x 0.6 ± 0.03 mm

Extraction Tool:

Part No. **1-1579007-2**

Product Group Drawing:

1241437

Product Specification:

108-18717

Application Specification:

114-18387

Standard Receptacle Contacts (SRC)

Wire Size Range (mm ²)	Insulation Diameter (mm)		Material and Finish*	Part Numbers					
	FLK	FLR		Strip Form**	Package Quantity	Loose-Piece	Package Quantity	Applicator ♦	Hand Tool 539635-1 with Die Set
0.20–0.35	–	1.1–1.4	–1 / –2 / –3	1564982	4,000	1564983	500	x-1157159-x	4-1579016-1
			–1 / –2 / –3	1241386	4,000	1241387	500	x-1528196-x	
0.5–1.0	–	1.4–2.1	–1 / –2 / –3	1241388	3,500	1241389	500	x-1528097-x	539951-2
>1.0–2.5	–	2.2–3.0	–1 / –2 / –3	1241390	3,500	1241391	500	x-1528001-x	

Receptacle Contacts Single Wire Sealing System (SWS)

Wire Size Range (mm ²)	Insulation Diameter (mm)		Material and Finish*	Part Numbers					
	FLK	FLR		Strip Form**	Package Quantity	Loose-Piece	Package Quantity	Applicator ♦	Hand Tool 539635-1 with Die Set
0.20–0.35	1.3–1.5	1.1–1.4	–1 / –2 / –3	1564984	3,500	1564985	500	x-1157160-x	4-1579016-1
			–1 / –2 / –3	1241392	3,500	1241393	500	x-1528232-x	
0.5–1.0	2.0–2.7	1.4–2.1	–1 / –2 / –3	1241394	3,500	1241395	500	x-1528101-x	539952-2
>1.0–2.5	2.2–3.0	2.2–3.0	–1 / –2 / –3	1241396	3,500	1241397	500	x-1528026-x	

***) Material and Finish:**

xxx-1 = CuNiSi, pre-tin plated
xxx-2 = CuNiSi, selective gold plated
xxx-3 = CuNiSi, selective silver plated

****)** Part No. **1241386** is replaced by Part No. **1564982**.

Part No. **1241386** not for new application.

Part No. **1241392** is replaced by Part No. **1564984**.

Part No. **1241392** not for new application.

♦) The pre- and suffix for the applicators depends on the applied termination equipment.

Tab Contacts

**Tabs 2.8 x 0.8 mm
with Steel Top Spring,
Mates with AMP MCP 2.8
Contact System**

Extraction Tool:
Part No. **1-1579007-6**
Product Group Drawing:
1355052
Product Specification:
108-18063
Application Specification:
114-18051

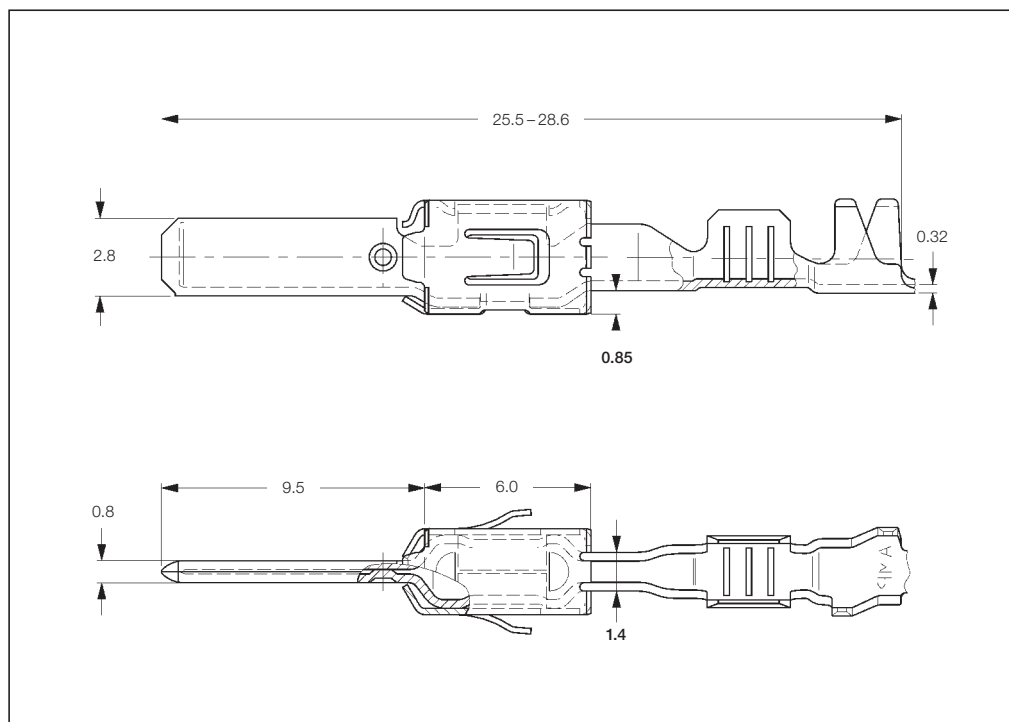

Standard Tab Contacts

Wire Size Range (mm ²)	Insulation Diameter		Material and Finish*	Part Numbers				Applicator*	Hand Tool Complete
	FLK (mm)	FLR (mm)		Strip Form	Package Quantity	Loose-Piece	Package Quantity		
0.2-0.5	-	1.15-1.60	1-xxx-1 / 1-xxx-2 / 1-xxx-3 / 2-xxx-1 / 2-xxx-2 / 2-xxx-3	963860	4,000	963861	500	x-1528859-x	734538-1
0.5-1.0	-	1.4-2.0	1-xxx-1 / 1-xxx-2 / 1-xxx-3 / 2-xxx-1 / 2-xxx-2 / 2-xxx-3	962841	4,000	963745	500	x-1528315-x	2063490-1
1.5-2.5	-	2.1-2.9	1-xxx-1 / 1-xxx-2 / 1-xxx-3 / 2-xxx-1 / 2-xxx-2 / 2-xxx-3	962842	3,500	963746	500	x-1528305-x	2063490-1
4.0	-	3.4-3.7	1-xxx-1 / 1-xxx-2 / 2-xxx-1 / 2-xxx-2 / 3-xxx-1	968946	2,700	968965	500	x-1528430-x	-

Tab Contacts with Single Wire Sealing System

Wire Size Range (mm ²)	Insulation Diameter		Material and Finish*	Part Numbers				Applicator*	Hand Tool Complete
	FLK (mm)	FLR (mm)		Strip Form	Package Quantity	Loose-Piece	Package Quantity		
0.2-0.5	-	max. 2.1	1-xxx-1 / 1-xxx-3	965982	3,500	965983	500	x-1528406-x	734538-1
0.5-1.0	-	max. 2.1	1-xxx-1 / 1-xxx-2 / 1-xxx-3 / 2-xxx-1 / 2-xxx-2 / 2-xxx-3	962915	3,500	963748	500	x-1528452-x	2063490-1
1.5-2.5	-	max. 3.0	1-xxx-1 / 1-xxx-2 / 1-xxx-3 / 2-xxx-1 / 2-xxx-2 / 2-xxx-3	962916	3,500	963749	500	x-1528316-x	2063490-1
4.0	-	max. 3.7	1-xxx-1 / 1-xxx-2 / 2-xxx-1 / 2-xxx-2 / 3-xxx-1	968947	3,500	968966	500	x-1528067-x	-

***) Material and Finish:**

1-xxx-1 = CuSn, pre-tin plated
1-xxx-2 = CuSn, selective silver plated
1-xxx-3 = CuSn, selective gold plated
2-xxx-1 = CuFe, pre-tin plated
2-xxx-2 = CuFe, selective silver plated
2-xxx-3 = CuFe, selective gold plated
3-xxx-1 = CuSn, pre-tin plated

***)** The pre- and suffix for the applicators depends on the applied termination equipment.

Tab Contacts

**Tabs 2.8 x 0.8 mm,
with Modified
Steel Top Spring,
Mates with AMP MCP 2.8/
2.8K Contact System**

Extraction Tool:
Part No. **1-1579007-6**

Product Group Drawing:
1355364

Product Specification:
108-18063

Application Specification:
114-18051

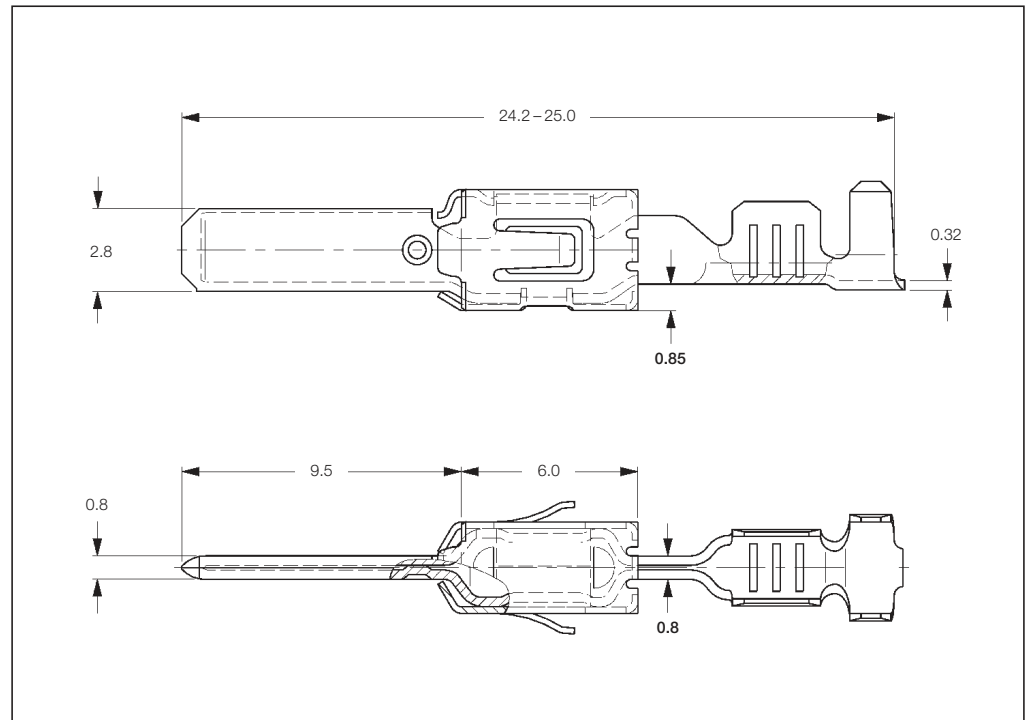

Standard Tab Contacts with Modified Spring (STC)

Wire Size Range (mm ²)	Insulation Diameter (mm)		Material and Finish *	Part Numbers				Applicator ♦	Hand Tool
	FLK	FLR		Strip Form	Package Quantity	Loose-Piece	Package Quantity		
0.2-0.5	-	1.15-1.60	1-xxx-3 / 2-xxx-1	964292	4,000	964291	500	x-1528004-x	
0.5-1.0	-	1.4-2.1	1-xxx-3 / 2-xxx-1 / 2-xxx-2	964294	4,000	964293	500	x-1528097-x	2063533-1
1.25-2.50	-	2.2-3.0	1-xxx-3 / 2-xxx-1 / 2-xxx-2	964296	3,300	964295	500	x-1528001-x	

Tab Contacts Single Wire Sealing System with Modified Spring (SWS)

Wire Size Range (mm ²)	Insulation Diameter (mm)		Material and Finish *	Part Numbers				Applicator ♦	Hand Tool
	FLK	FLR		Strip Form	Package Quantity	Loose-Piece	Package Quantity		
0.2-0.5	-	1.15-1.60	1-xxx-3 / 2-xxx-1	964298	3,500	964297	500	x-1528025-x	
0.5-1.0	-	1.4-2.1	1-xxx-3 / 2-xxx-1 / 4-xxx-1	964300	3,500	964299	500	x-1528101-x	2063435-1
1.25-2.50	-	2.2-3.0	1-xxx-3 / 2-xxx-1	964302	3,500	964301	500	x-1528026-x	

*) **Material and Finish:**
 1-xxx-3 = CuSn, selective gold plated
 2-xxx-1 = CuFe, pre-tin plated
 2-xxx-2 = CuFe, pre-silver plated
 4-xxx-1 = CuNi, plain

♦) The pre- and suffix for the applicators depends on the applied termination equipment.

Single Wire Seals and Sealing Plugs

Single Wire Seals and Sealing Plugs for AMP MCP 2.8 Contact System (Two Cavity Diameters)

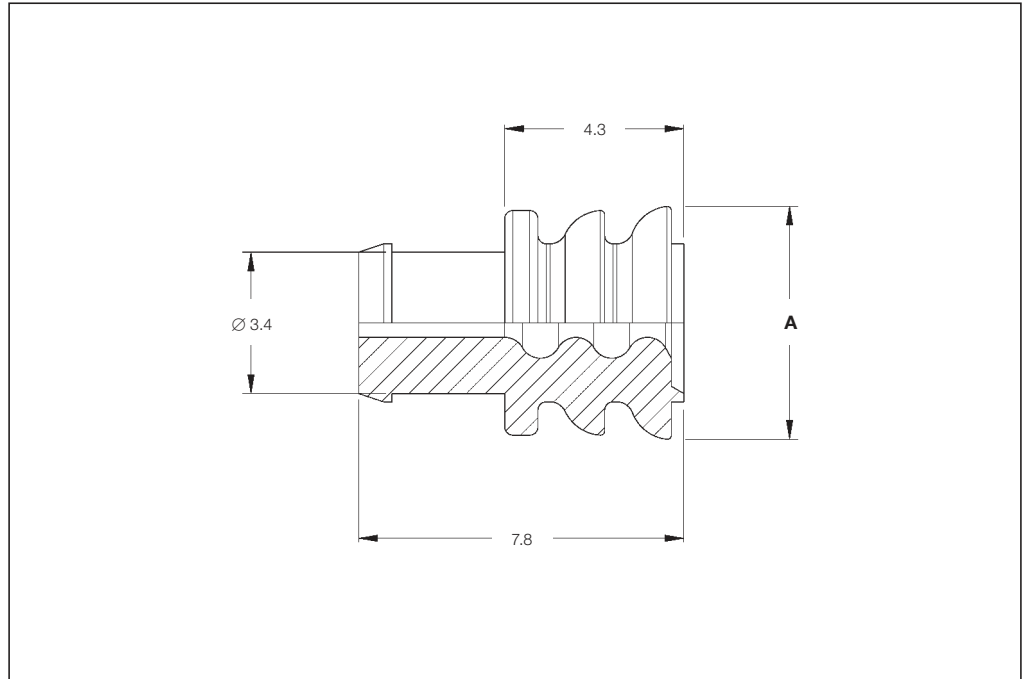

Cavity Size	Function Relevant Insulation Diameter (mm)	(Example for Wire Size, FLR Insulation according ISO 6722 (mm ²))	Color	Diameter A (mm)	Part Number	Package Quantity
A	1.2-2.1	(0.35-1.00)	Blue	5.6	828904-1	1,000
					828904-2	10,000
A	2.2-3.0	(1.5-2.5)	White	5.6	828905-1	10,000
B	3.0-3.7	(2.5-4.0)	Green	7.2	828985-1	5,000
A	Sealing Plug		Natural	5.6	828922-1	10,000
B	Sealing Plug		Brown	7.2	828986-1	5,000

For correct use see Application Specification 114-18148.

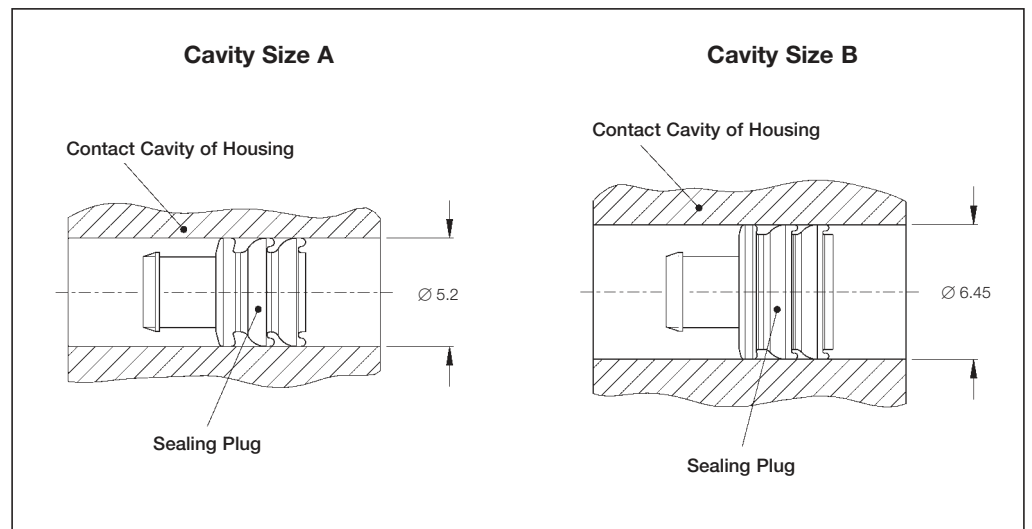

Single Wire Seals and Sealing Plugs

Single Wire Seals and Sealing Plugs for AMP MCP 2.8K Contact System (Cavity Diameter 5.2 mm)

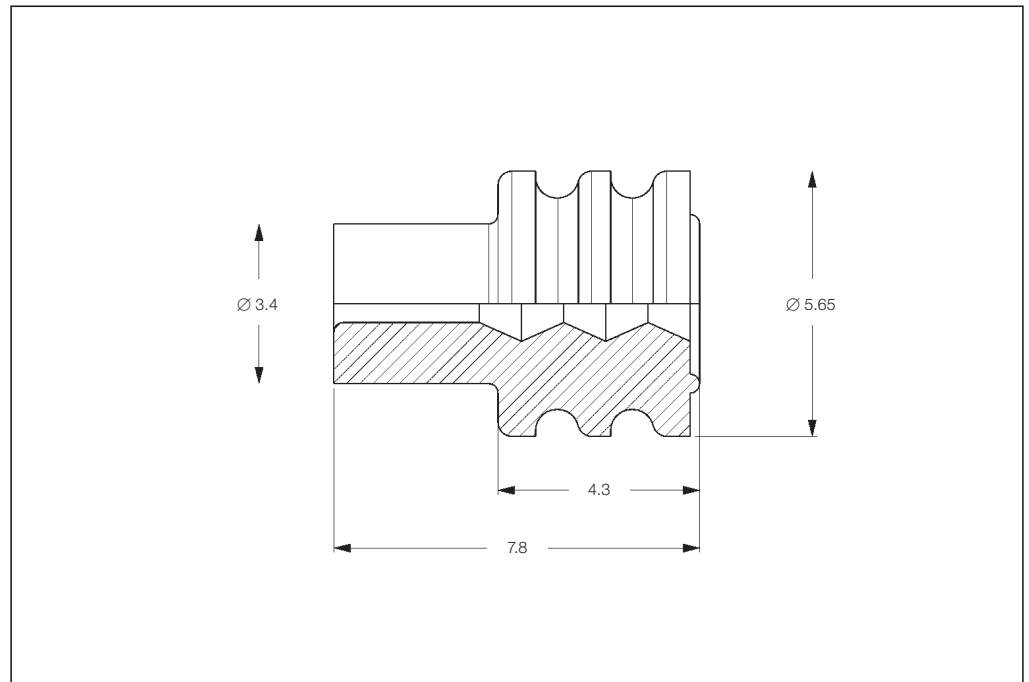

Wire Size Range (mm ²)		Insulation Diameter (mm)	Color	Part Number	Package Quantity
FLK	FLR				
0.35	0.35-1.00	1.2-2.1	Blue	963294-1	5,000
0.5-1.0	1.5	2.0-2.7	Red-Brown	963293-1	5,000
1.5	2.5	2.7-3.0	Yellow	963292-1	5,000
-	-	Sealing Plug	Natural	828922-1	10,000
-	-		Green	828922-2	10,000

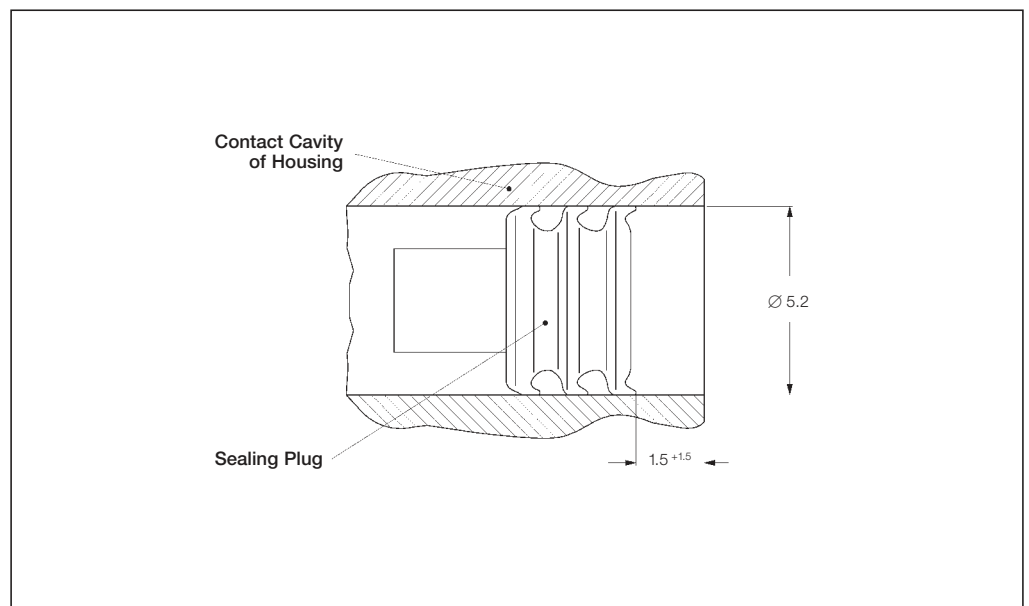

Engineering Notes

A large grid area for engineering notes, consisting of a uniform grid of small squares. The grid is empty and occupies the majority of the page's vertical space.

Receptacle Contacts

Technical Features

Contact Material:

CuNiSi
Top Spring: Stainless Steel

Contact Finish:

Tin plated, selective silver plated

Wire Size Range:

0.2–0.5 mm², 0.5–1.0 mm²,
>1.0–2.5 mm², >2.5–4.0 mm²,
>4.0–6.0 mm²

Current Carrying Capacity:

up to 40 Ampere
(at 20 °C ambient temperature)

Temperature Range:

–40 °C ... +130 °C (tin plated)
–40 °C ... +140 °C (silver plated)
–40 °C ... +140 °C (tin-silver)

Modular Dimensions (Centerline):

0.2–6.0 mm² SRC:

– 6.0 x 8.0 mm

0.2–6.0 mm² SWS:

– 9.0 x 9.0 mm

– 8.0 x 9.0 mm (Staggered)

Dimension of Male Contacts:

4.8 ±0.1 x 0.8 ±0.03 mm

5.8 ±0.1 x 0.8 ±0.03 mm

6.3 ±0.1 x 0.8 ±0.03 mm

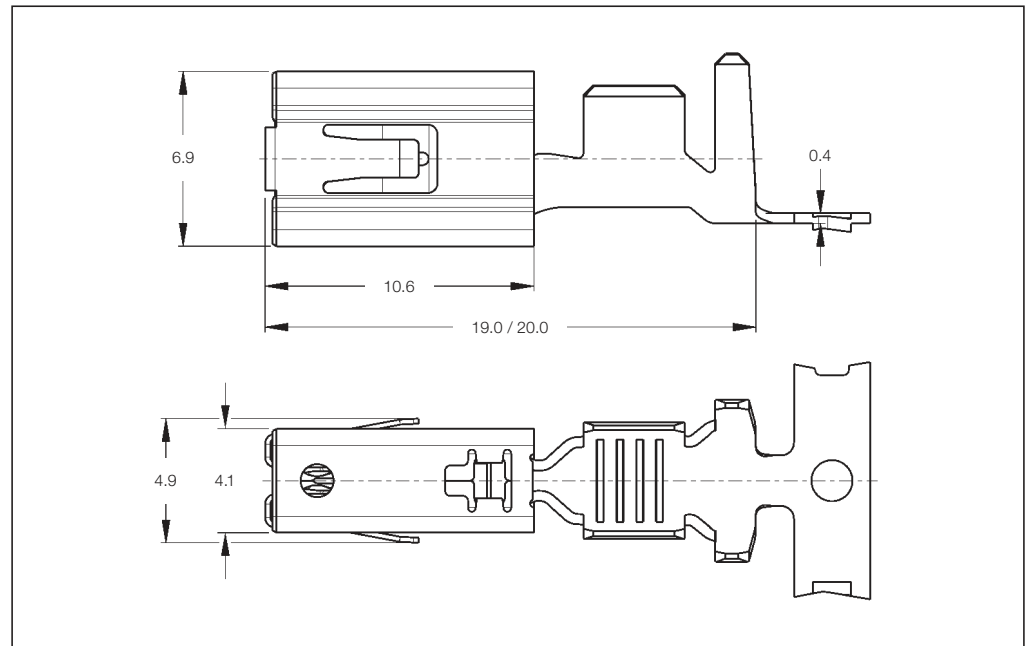

Contact Resistance:

New State ≤ 2 mΩ

Mating Cycles: ●

up to 10 cycles (tin plated)

up to 50 cycles (silver plated)

Mating Force: Max. 12 N

Unmating Force: Max. 11 N

Extraction Tool:

Part No. **1-1579007-3**

Product Group Drawing:

1241438

Product Specification:

108-18718

Application Specification:

114-18388

-) The maximum number of mating cycles is dependent on the tribological properties of the used surfaces in each case. Only by using the relevant/matching surfaces and contact geometries, receptacle and tab contacts produced and delivered by TE Automotive, the maximum number of insertions can be achieved.

Standard Receptacle Contacts (SRC)

Wire Size Range (mm ²)	Insulation Diameter (mm)		Material and Finish*	Part Numbers					
	FLK	FLR		Strip Form	Package Quantity	Loose-Piece	Package Quantity	Applicator †	Hand Tool
0.2–0.5	–	1.1–1.6	-1	1241400	1,800	1241401	500	x-1530002-x	
0.5–1.0	–	1.4–2.1	-1 / -3	1241402	1,800	1241403	500	x-1528206-x	539953-2
>1.0–2.5	–	2.2–3.0	-1 / -3	1241404	2,000	1241405	500	x-1528095-x	
>2.5–4.0	3.3–4.5	–	-1 / -3	1241406	2,000	1241407	500	x-1528298-x	
>4.0–6.0	–	3.4–4.3	-1	1241408	1,700	1241409	500	x-1528895-x	539954-2

Receptacle Contacts Single Wire Sealing System (SWS)

Wire Size Range (mm ²)	Insulation Diameter (mm)		Material and Finish*	Part Numbers					
	FLK	FLR		Strip Form	Package Quantity	Loose-Piece	Package Quantity	Applicator †	Hand Tool
0.2–0.5	1.3–2.3	1.1–1.6	-1	1241410	1,500	1241411	500	x-1528513-x	539955-2
0.5–1.0	2.0–2.7	1.4–2.1	-1 / -3	1241412	1,500	1241413	500	x-1528342-x	
>1.0–2.5	2.7–3.7	2.2–3.0	-1 / -3	1241414	1,500	1241415	500	x-1528231-x	539956-2
>2.5–4.0	4.1–4.5	3.4–3.7	-1 / -3	1241416	1,500	1241417	500	x-1530003-x	
>4.0–6.0	–	4.0–4.5	-4	1241418	1,500	1241419	500	x-1528947-x	3-1579021-7

***) Material and Finish:**

xxx-1 = CuNiSi, pre-tin plated
xxx-3 = CuNiSi, selective silver plated
xxx-4 = CuNiSi, tin-silver pre-plated

- †) The pre- and suffix for the applicators depends on the applied termination equipment.

Tab Contacts

**Tabs 5.8 x 0.8 mm
with Steel Top Spring,
Mates with
AMP MCP 6.3/4.8K
Contact System**

Extraction Tool:
Part No. **1-1579007-6**

Product Group Drawing:
1241895

Product Specification:
108-18064

Application Specification:
114-18052

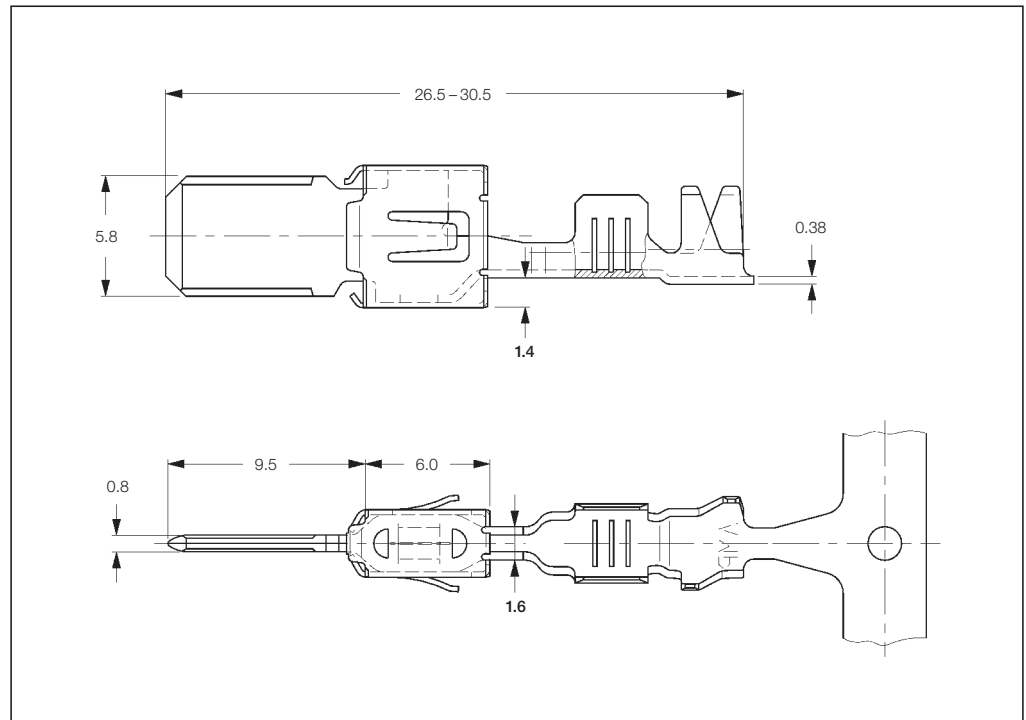

Standard Tab Contacts (STC)

Wire Size Range (mm ²)	Insulation Diameter (mm)		Material and Finish*	Part Numbers					
	FLK	FLR		Strip Form	Package Quantity	Loose-Piece	Package Quantity	Applicator	Hand Tool 539635-1 with Die Set
1.5-2.5	2.4-3.7	-	1-xxx-1 / 1-xxx-2 / 2-xxx-1 / 2-xxx-2	962845	1,700	963740	500	On request	
3.0-4.0	3.3-4.5	-	1-xxx-1 / 1-xxx-2 / 2-xxx-1 / 2-xxx-2	962846	1,800	963741	500	On request	539759-2
0.5-1.0	-	1.4-2.1	1-xxx-1 / 1-xxx-2 / 2-xxx-1 / 2-xxx-2	963734	1,700	963737	500	On request	
1.5-2.5	-	2.2-3.0	1-xxx-1 / 1-xxx-2	963735	1,800	963738	500	On request	734688-1** 539623-1** for 2.5
>2.5-4.0	-	2.7-3.7	1-xxx-1 / 1-xxx-2 / 2-xxx-1 / 2-xxx-2	963736	1,800	963739	500	On request	539623-1**
0.2-0.5	-	1.15-1.60	1-xxx-1 / 2-xxx-1	965984	2,000	965985	500	-	-
4.0-6.0	4.0-5.2	-	1-xxx-1 / 2-xxx-1	968050	1,500	968051	500	On request	-

Tab Contacts Single Wire Sealing System (SWS)

Wire Size Range (mm ²)	Insulation Diameter (mm)		Material and Finish*	Part Numbers					
	FLK	FLR		Strip Form	Package Quantity	Loose-Piece	Package Quantity	Applicator	Hand Tool 539635-1 with Die Set
0.5-1.0	-	1.4-2.1	1-xxx-1 / 1-xxx-2 / 2-xxx-1 / 2-xxx-2	962917	1,500	963742	500	On request	
1.5-2.5	-	2.2-3.0	1-xxx-1 / 1-xxx-2 / 2-xxx-1 / 2-xxx-2	962918	1,500	963743	500	On request	539757-2
>2.5-4.0	-	2.7-3.7	1-xxx-1 / 1-xxx-2 / 2-xxx-1 / 2-xxx-2	962919	1,500	963744	500	On request	
4.0-6.0	-	3.6-5.1	2-xxx-2	2112966	1,500	2112965	500	1855636	-

***) Material and Finish:**

1-xxx-1 = CuSn, pre-tin plated
1-xxx-2 = CuSn, selective silver plated

2-xxx-1 = CuFe, pre-tin plated
2-xxx-2 = CuFe, selective silver plated

Remarks:

****)** Hand Tool complete

Tab Contacts

**Tabs 5.8 x 0.8 mm,
with Modified
Steel Top Spring,
Mates with
AMP MCP 6.3/4.8K
Contact System**

Extraction Tool:
Part No. **1-1579007-6**

Product Group Drawing:
1394011

Product Specification:
108-18064

Application Specification:
114-18052

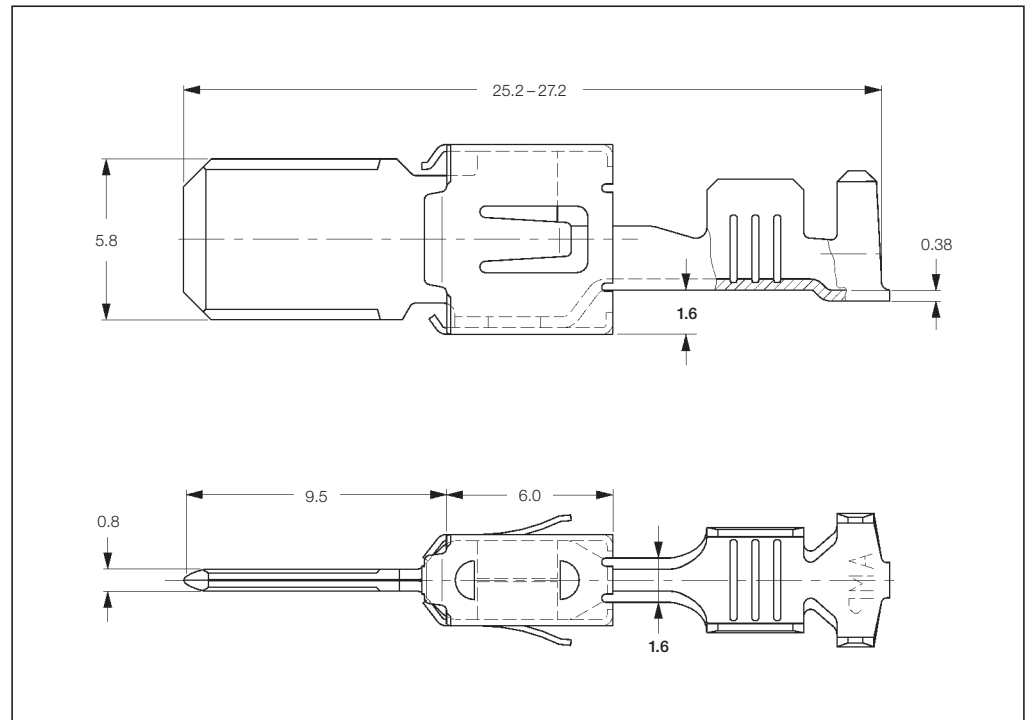

Standard Tab Contacts with Modified Spring (STC)

Wire Size Range (mm ²)	Insulation Diameter (mm)		Material and Finish*	Part Numbers					
	FLK	FLR		Strip Form	Package Quantity	Loose-Piece	Package Quantity	Applicator ♦	Hand Tool
0.2-0.5	-	1.15-1.60	-1	969007	1,800	969008	500	x-1528296-x	
0.5-1.0	-	1.4-2.1	-1	964304	1,800	964303	500	x-1528093-x	2063536-1
> 1.0-2.5	-	2.2-3.0	-1 / -3	964306	1,900	964305	500	x-1528094-x	
> 2.5-4.0	3.3-4.5	3.3-4.5	-1	964308	1,800	964307	500	x-1530004-x	

Tab Contacts Single Wire Sealing System with Modified Spring (SWS)

Wire Size Range (mm ²)	Insulation Diameter (mm)		Material and Finish*	Part Numbers					
	FLK	FLR		Strip Form	Package Quantity	Loose-Piece	Package Quantity	Applicator ♦	Hand Tool
0.5-1.0	-	1.4-2.1	-1	964310	1,500	964309	500	x-1528437-x	
> 1.0-2.5	-	2.2-3.0	-1	964312	1,400	964311	500	x-1528444-x	2063560-1
> 2.5-4.0	-	2.7-3.7	-1	964314	1,300	964313	500	x-1528439-x	

*) **Material and Finish:**
xxx-1 = CuFe, pre-tin plated
xxx-3 = CuSn, selective gold plated

♦) The pre- and suffix for the applicators depends on the applied termination equipment.

Single Wire Seals and Sealing Plugs

**Single Wire Seals
and Sealing Plugs
for AMP MCP 6.3/4.8K
Contact System**
(Cavity Diameter see below)

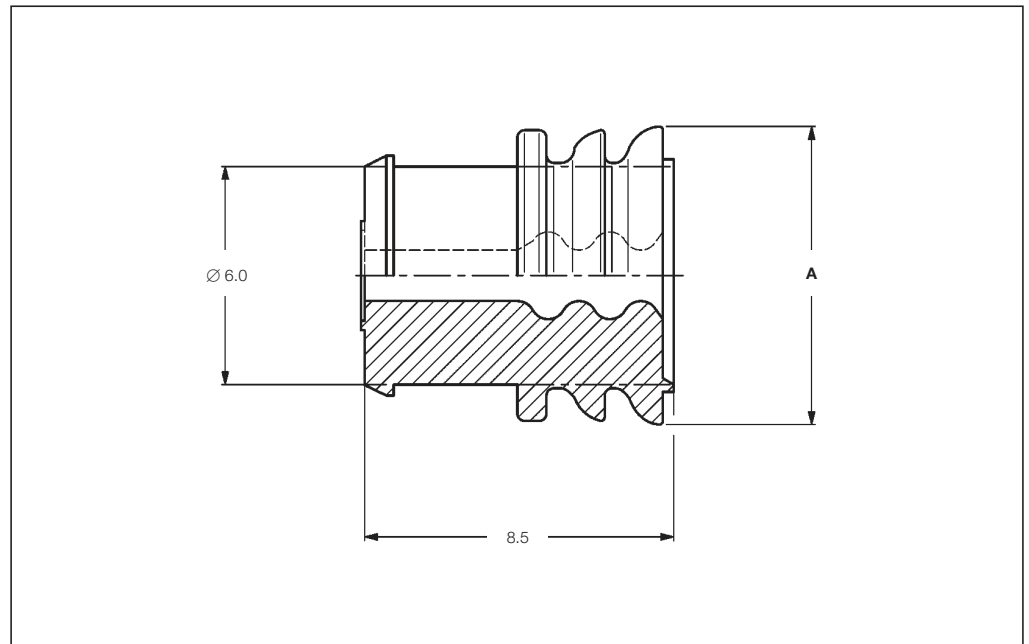

Insulation Diameter (mm)	Color	Diameter A (mm)	Part Number	Package Quantity
1.4-2.1	Blue	8.2	963243-1	2,500
2.2-3.0	White	8.2	963244-1	2,500
3.4-3.7	Yellow	8.2	963245-1	2,500
Sealing Plug	Black	8.1	100132-1	1,000

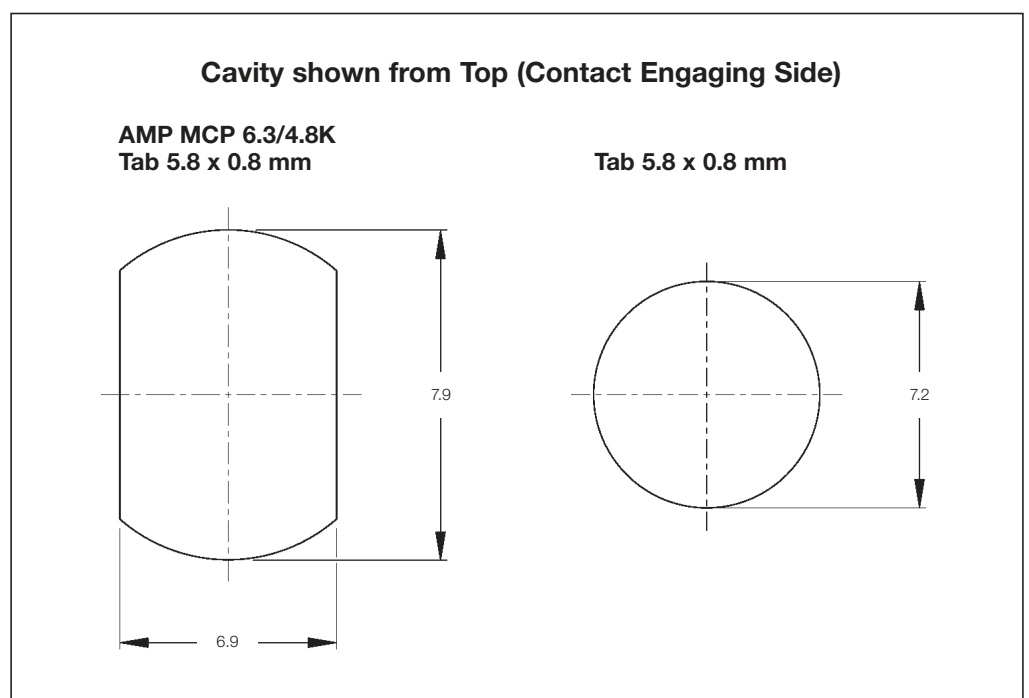

Single Wire Seals and Sealing Plugs

Single Wire Seals and Sealing Plugs for AMP MCP 6.3/4.8K Contact System (Cavity Diameter 8.5 mm)

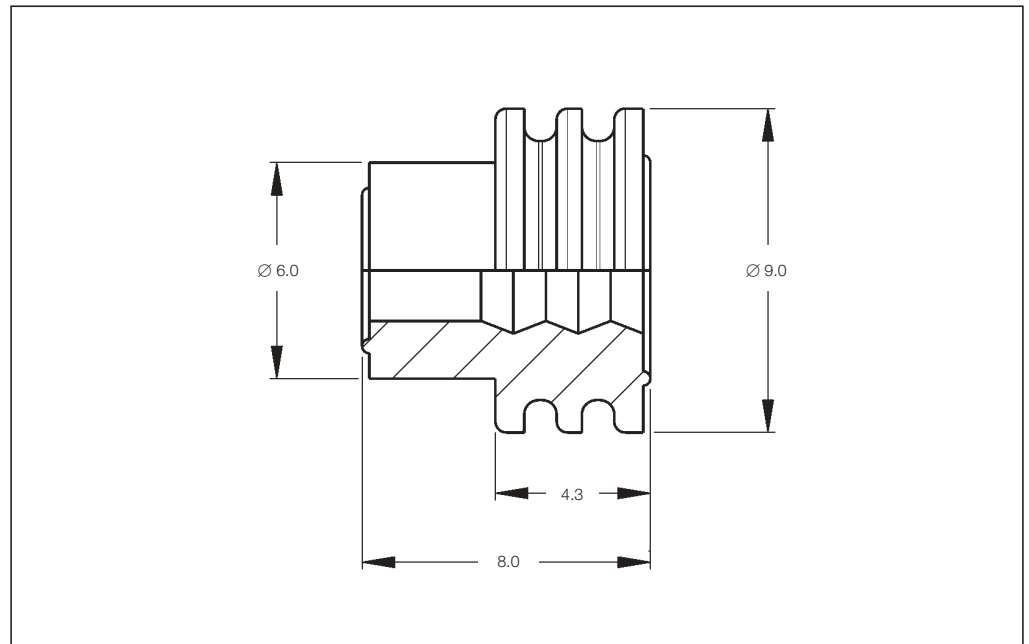

Insulation Diameter (mm)	Color	Part Number	Package Quantity
2.0-2.7	White	1394511-1	10,000
3.4-3.7	Blue	1394512-1	10,000
4.0-4.5	Green	1719043-1	10,000
Sealing Plug	Transparent	967652-1	20,000

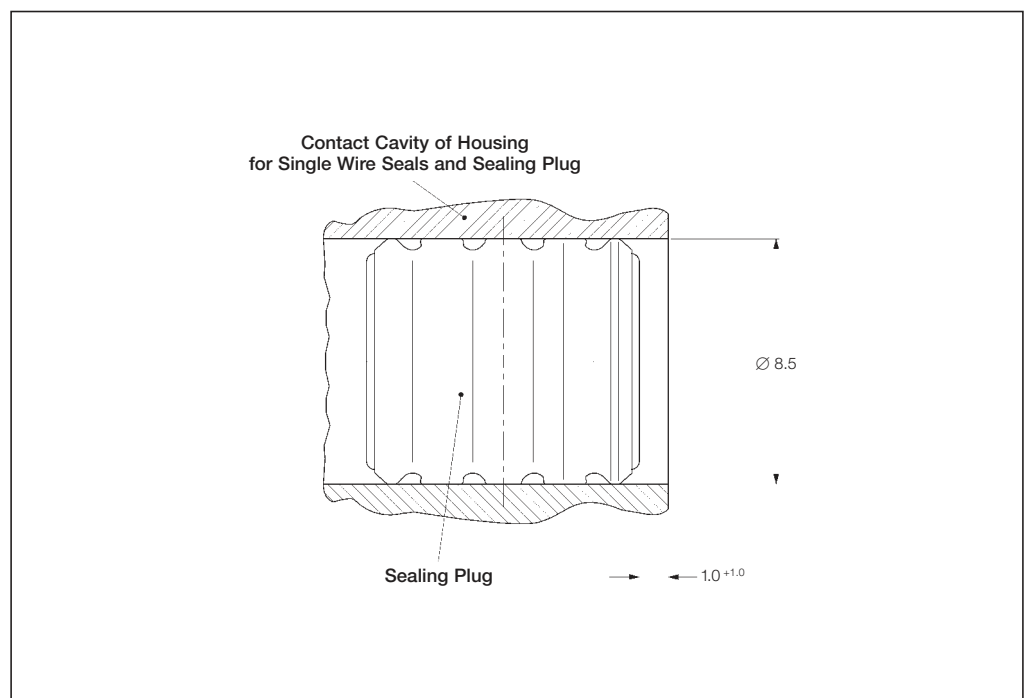

Engineering Notes

A large grid area for engineering notes, consisting of a uniform grid of small squares. The grid is empty and occupies the majority of the page's vertical space.

Lanceless Receptacle Contacts

Technical Features

Material:

Contact: CuNiSi
Tabs: CuSn4, CuFe2
Top Spring: Stainless Steel

Contact Finish:

Tin plated

Wire Size Range:

6.0–10.0 mm²

Current Carrying Capacity:

up to 80 Ampere
(at 20 °C ambient temperature)

Temperature Range:

–40 °C ... +130 °C (tin plated)

Mating Cycles: ●

up to 10 cycles (tin plated)

**Modular Dimensions
(Centerline):**

6.0–10.0 mm² SRC:
– 12.7 x 9.5 mm
– 12.7 x 8.5 mm (Staggered)

Mating Force:

Max. 35 N

Unmating Force:

Max. 15 N

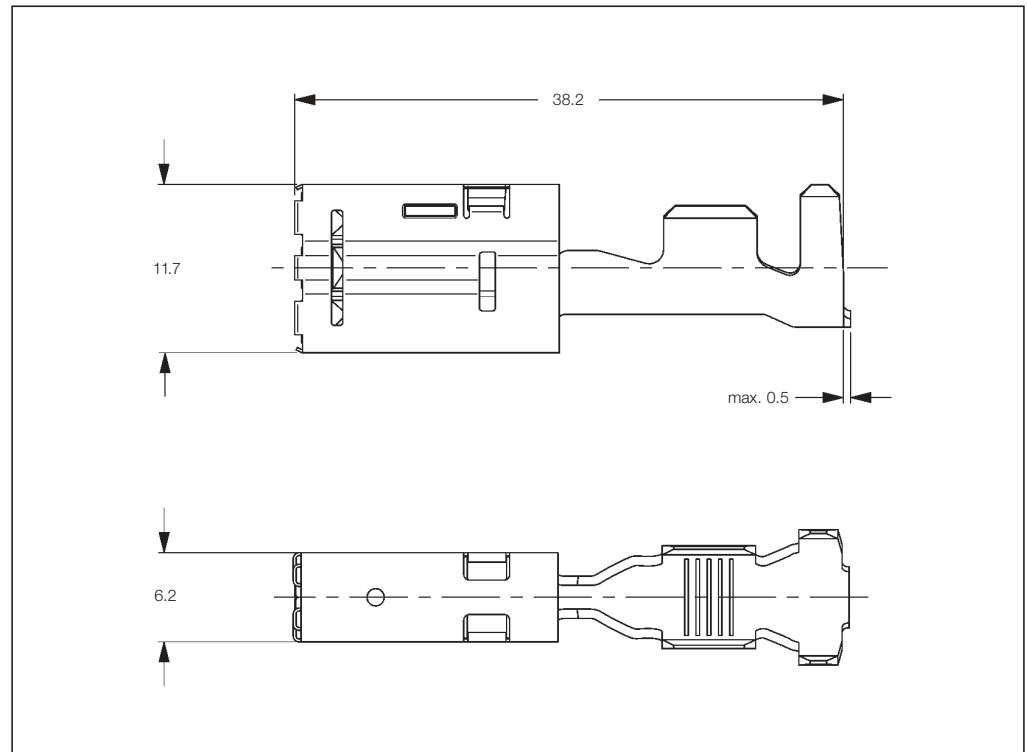

Contact Resistance:

New State ≤ 4 mΩ

Extraction Tool:

Extraction possible without tool

Product Specification:

108-18630

Application Specification:

114-18269

- The maximum number of mating cycles is dependent on the tribological properties of the used surfaces in each case. Onl by using the relevant/matching surfaces and contact geometries, receptacle and tab contacts produced and delivered by TE Automotive, the maximum number of insertions can be achieved.

Lanceless Receptacle Contacts

Wire Size Range (mm ²)	Insulation Diameter (mm)		Material and Finish *	Part Numbers					
	FLK	FLR		Strip Form	Package Quantity	Loose-Piece	Package Quantity	Applicator	Hand Tool 539783-1 with Die Set
6.0–10.0	4.6–6.6	–	1-xxx-1	1355849	600	–	–	On request	539783-5 for 6 mm 539783-6 for 10 mm

***) Material and Finish:**

1-xxx-1 = CuNiSi, pre-tin plated

Receptacle Contacts

Technical Features

Material:

Contact: CuNiSi
Tabs: CuSn4, CuFe2
Top Spring: Stainless Steel

Contact Finish:

Tin plated,
selective silver plated

Wire Size Range:

6.0–10.0 mm², >10.0–16.0 mm²

Current Carrying Capacity:

up to 100 Ampere
(at 20 °C ambient temperature)

Temperature Range:

–40 °C ... +130 °C (tin plated)
–40 °C ... +140 °C (silver plated)

Mating Cycles:●

up to 10 cycles (tin plated)
up to 50 cycles (silver plated)

**Modular Dimensions
(Centerline):**

3.0–10.0 mm² SRC:
– 12.7 x 9.5 mm
– 12.7 x 8.5 mm (Staggered)

10.0–16.0 mm² SRC:
– 12.7 x 10.5 mm
– 12.7 x 9.0 mm (Staggered)

6.0–10.0 mm² SWS:
– 16.0 x 16.0 mm
– 16.0 x 14.0 mm (Staggered)

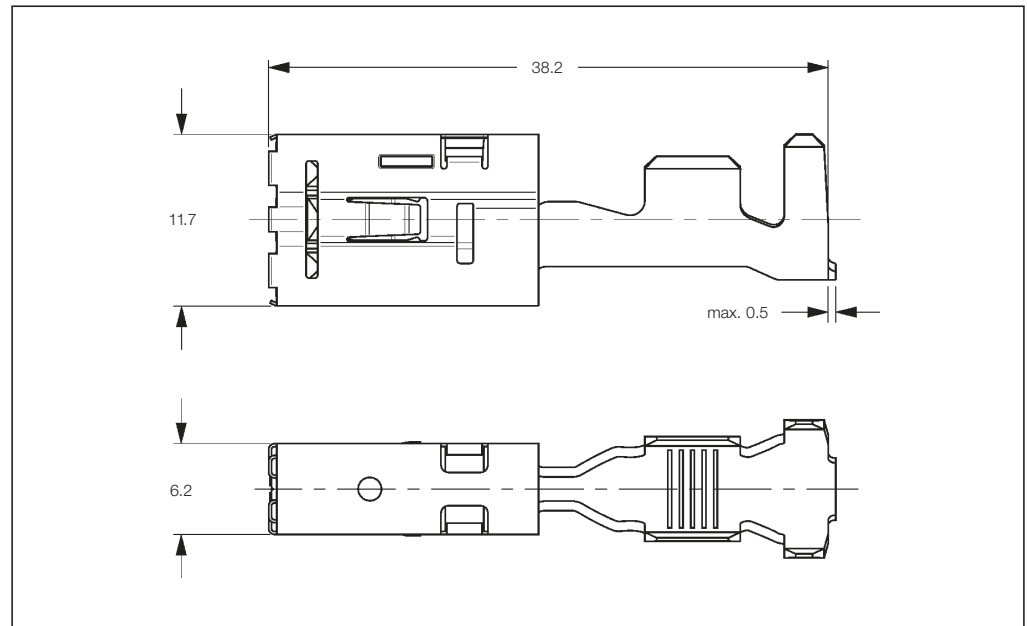

Contact Resistance:
New State ≤ 4 mΩ

Mating Force:
Max. 35 N

Unmating Force:
Max. 15 N

Extraction Tool:
Part No. **539971-1**

Product Group Drawing:
1355037 for tab 9.5 x 1.2
(ISO 8092 standard)
1241994 for tab 9.5 x 0.8

Product Specification:
108-18630

Application Specification:
114-18269

●) The maximum number of mating cycles is dependent on the tribological properties of the used surfaces in each case. Onl by using the relevant/matching surfaces and contact geometries, receptacle and tab contacts produced and delivered by TE Automotive, the maximum number of insertions can be achieved.

Standard Receptacle Contacts (SRC)

Wire Size Range (mm ²)	Insulation Diameter (mm)		Material and Finish *	Part Numbers					
	FLK	FLR		Strip Form	Package Quantity	Loose-Piece	Package Quantity	Applicator	Hand Tool 539783-1 with Die Set
3.0–6.0	4.0–5.2	–	1-xxx-1	1719386**	600	1719385	500	–	–
6.0–10.0	4.6–6.6	–	1-xxx-1	967588	600	929150	500	On request	539783-5 for 6 mm 539783-6 for 10 mm
			1-xxx-1 / 1-xxx-2	1241930**	500	–	–	On request	539783-5 for 6 mm 539783-6 for 10 mm
>10.0–16.0	7.1–8.1	–	1-xxx-1 / 1-xxx-2	967589	500	929151	500	On request	539783-7

Receptacle Contacts Single Wire Sealing System (SWS)

Wire Size Range (mm ²)	Insulation Diameter (mm)		Material and Finish	Part Numbers					
	FLK	FLR		Strip Form	Package Quantity	Loose-Piece	Package Quantity	Applicator	Hand Tool 539783-1 with Die Set
6.0–10.0	4.6–6.6	–	1-xxx-1	967590	500	929152	500	On request	539783-8 for 6 mm 539783-9 for 10 mm
>10.0–16.0	7.1–8.1	–	1-xxx-1	967591	500	929153	500	On request	1-539783-0

***) Material and Finish:**

1-xxx-1 = CuNiSi, pre-tin plated
1-xxx-2 = CuNiSi, selective silver plated

****) For Tab 9.5 x 0.8 mm**

Tab Contacts

**Tabs 9.5 x 1.2 mm
with Steel Top Spring,
Mates with AMP MCP 9.5
Contact System**

Extraction Tool:
Part No. **1-1579007-7**

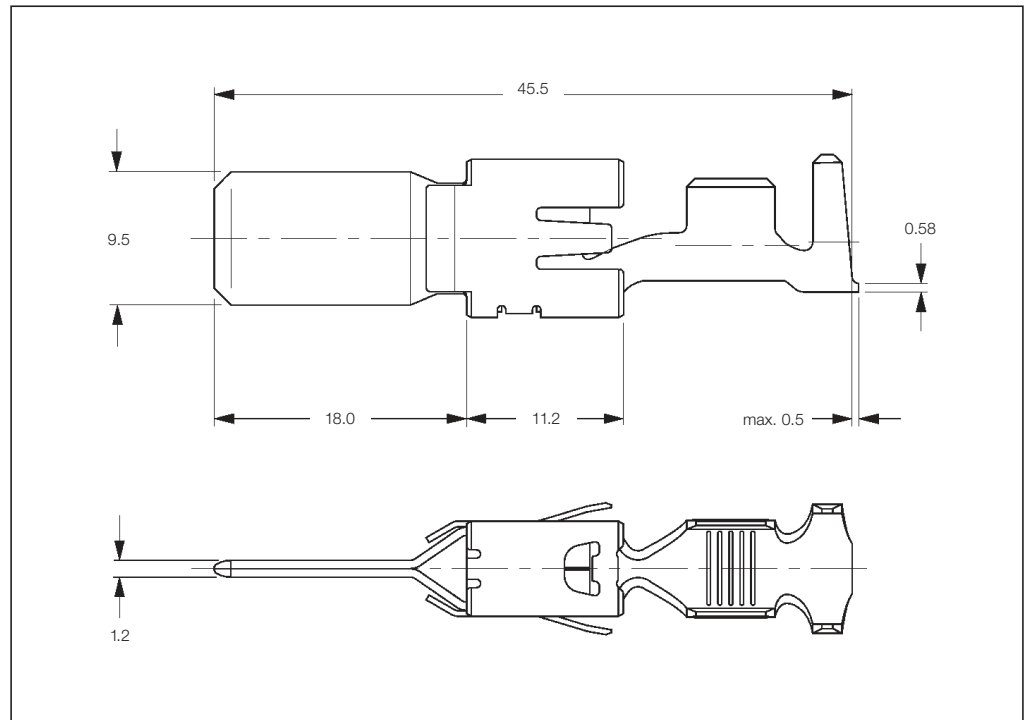

Standard Tab Contacts (STC)

Wire Size Range (mm ²)	Insulation Diameter (mm)		Material and Finish*	Part Numbers				Applicator	Hand Tool
	FLK	FLR		Strip Form	Package Quantity	Loose-Piece	Package Quantity		
2.5-4.0	3.3-4.7	-	-1 / -2	963764	700	963765	500	On request	734532-1
4.0-6.0	4.0-5.2	-	-1 / -2	963766	700	963767	500	On request	734533-1
6.0-10.0	4.7-6.6	-	-1 / -2	963768	700	963769	500	On request	734533-1

Tab Contacts Single Wire Sealing System (SWS)

Wire Size Range (mm ²)	Insulation Diameter (mm)		Material and Finish*	Part Numbers				Applicator	Hand Tool
	FLK	FLR		Strip Form	Package Quantity	Loose-Piece	Package Quantity		
2.5-4.0	4.0-4.5	-	-1 / -2	963770	550	963771	500	On request	-
4.0-6.0	4.7-5.3	-	-1 / -2	963772	550	963773	500	On request	-
6.0-10.0	6.2-6.6	-	-1 / -2	963774	550	963775	500	On request	-

***) Material and Finish:**
 -1 = CuSn, pre-tin plated
 -2 = CuFe, pre-tin plated
 -3 = CuSn0.15, pre-tin plated

Single Wire Seals and Sealing Plugs

Single Wire Seals and Sealing Plugs for AMP MCP 9.5 Contact System

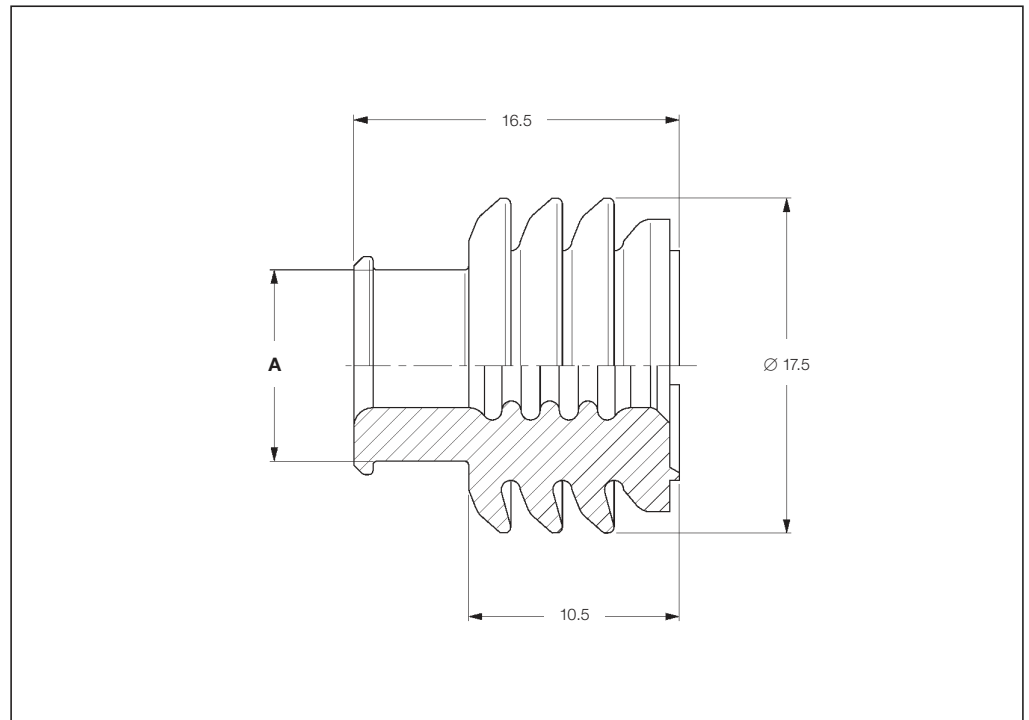

Wire Size Range (mm ²)	Insulation Diameter (mm)	Color	Part Number	Package Quantity	Dimension A (mm)
6.0	4.6–5.2	Violet	1355437-1	4,000	10.0
10.0	5.8–6.6	Blue	1355437-2	4,000	10.0
16.0	7.1–8.1	Red	1355437-3	4,000	10.8
–	Sealing Plug	–	–	–	–

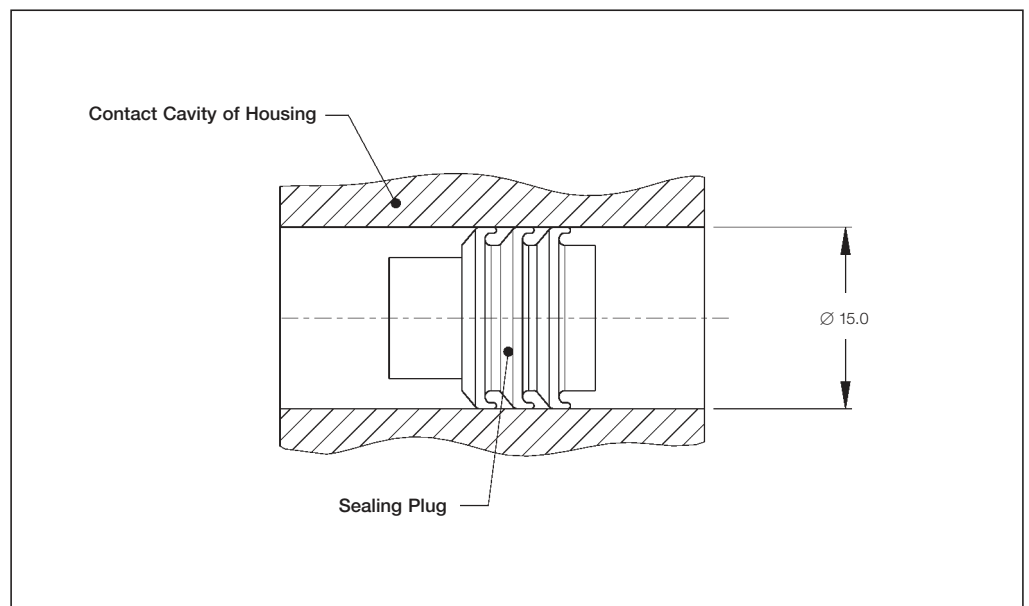

Introduction



The AMP MCP Connector System offers receptacle and tab housings with capability for waterproofing and resistance to conditions of extreme vibration.

The system is designed for electronic and electrical applications in motor vehicles, where vibrations and mechanical stress, in the long term, can affect the quality on the contact system.

AMP MCP Connectors

- High reliability status supported for long term use
- High vibration level supported
- Perfect design to avoid quality problems, reduce manufacturing and service cost
- Integrated secondary locking device delivered in pre-locked position
- Wire-to-wire sealed and unsealed connectors (SWS)
- Wire-to-board sealed and unsealed connectors (SWS)
- Polarisation, several keyings
- Locking mechanism for smaller connectors/mating aid for higher numbers of ways

Unsealed AMP MCP 1.5K Receptacle Housings

Technical Features

No. of Positions:

32 (22+10) Positions

Housing Material:

22 Position: PBT/ASA-GF20

10 Position: PBT-GF10

Wire Size Range:

AMP MCP 1.5K: 0.2–1.5 mm²

AMP MCP 2.8K: 0.2–2.5 mm²

AMP MCP 4.8K: 0.2–4.0 mm²

Product Specification:

108-18950

Application Specification:

114-18619-001

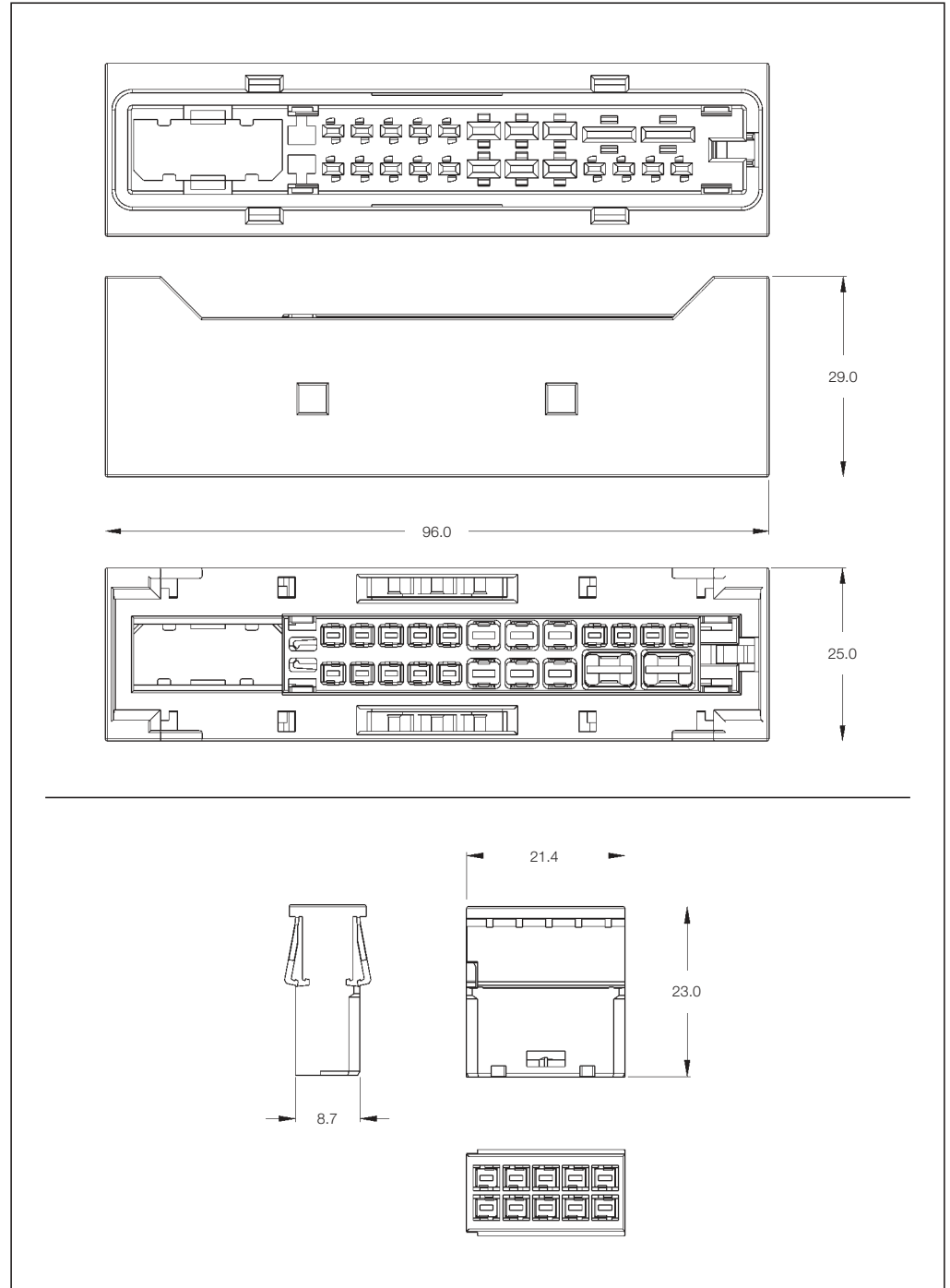

Receptacle Housings with 22 Pos. and 10 Pos. AMP MCP

No. of Positions	Keying Options	Housing Color	Part Numbers			
			Receptacle Housing, 22 Positions	Receptacle Housing, 10 Positions	Cover and Lever	Mating PCB Header Right-Angle
22+10	-	Black / Slider Right	1534180-1	1534181-1	1534184-1	1534046-1
		Black / Slider Left	1534180-2	1534181-1	1534184-2	1534046-1

Unsealed AMP MCP 1.5K Receptacle Housings

Technical Features

No. of Positions:

32 (22+10) Positions

Housing Material:

22 Position: PBT/ASA-GF20

10 Position: PBT-GF10

Wire Size Range:

AMP MCP 1.5K: 0.2–1.5 mm²

AMP MCP 2.8K: 0.2–2.5 mm²

AMP MCP 4.8K: 0.2–4.0 mm²

Product Specification:

108-18950

Application Specification:

114-18619-001

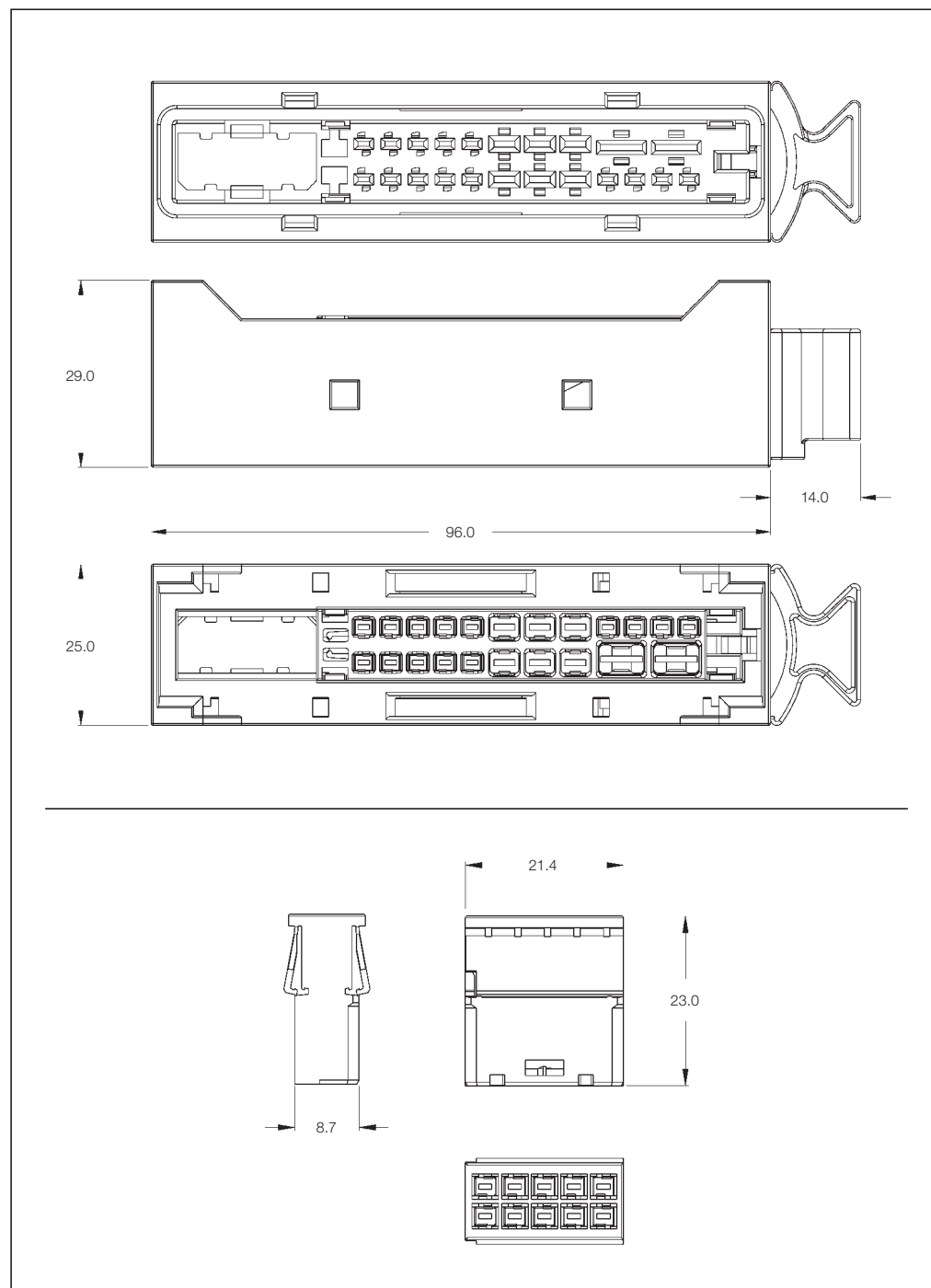

Receptacle Housings with 22 Pos. and 10 Pos. AMP MCP

No. of Positions	Keying Options	Housing Color	Part Numbers			
			Receptacle Housing, 22 Positions	Receptacle Housing, 10 Positions	Cover and Lever	Mating PCB Header Right-Angle
22+10	–	Black	1534399-1	1534181-1	–	1534046-1

Unsealed AMP MCP 1.5K Receptacle Housings

Technical Features

No. of Positions:

38 (22+16) Positions

Housing Material:

22 Position: PBT/ASA-GF20

10 Position: PBT-GF10

Wire Size Range:

AMP MCP 1.5K: 0.2–1.5 mm²

AMP MCP 2.8K: 0.2–2.5 mm²

AMP MCP 4.8K: 0.2–4.0 mm²

Product Specification:

108-18950

Application Specification:

114-18619-001

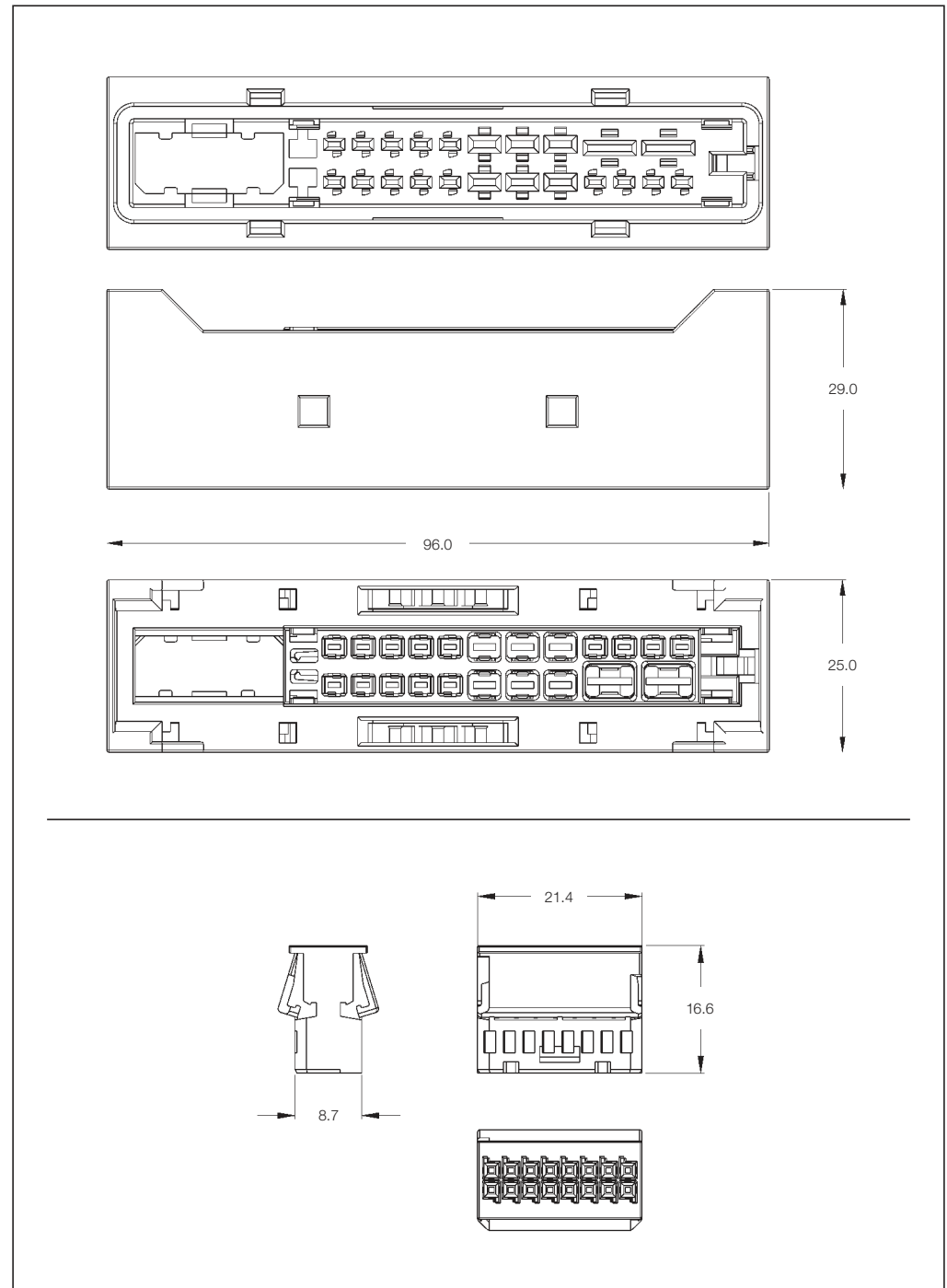

Receptacle Housings with 22 Pos. AMP MCP + 16 Pos. MQS (Micro Quadlok)

No. of Positions	Keying Options	Housing Color	Part Numbers			
			Receptacle Housing, 22 Positions	Receptacle Housing, 16 Positions	Cover and Lever	Mating PCB Header Right-Angle
22+16	-	Black / Slider Right	1534180-1	1534579-1	1534184-1	1534531-1
		Black / Slider Left	1534180-2	1534579-1	1534184-2	1534531-1

Unsealed AMP MCP 1.5K Receptacle Housings

Technical Features

No. of Positions:

38 (22+16) Positions

Housing Material:

22 Position: PBT/ASA-GF20

10 Position: PBT-GF10

Wire Size Range:

AMP MCP 1.5K: 0.2–1.5 mm²

AMP MCP 2.8K: 0.2–2.5 mm²

AMP MCP 4.8K: 0.2–4.0 mm²

Product Specification:

108-18950

Application Specification:

114-18619-001

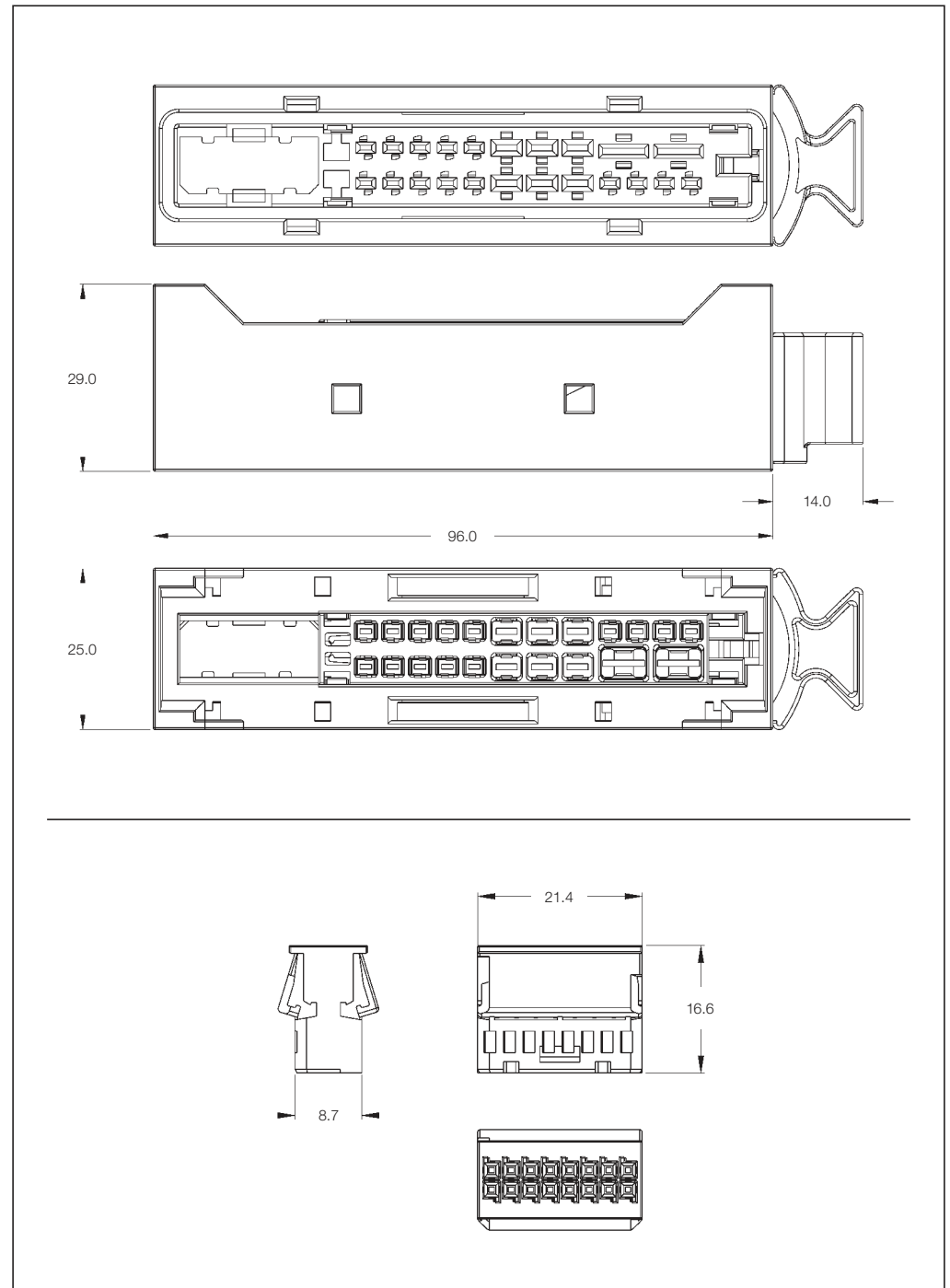

Receptacle Housings with 22 Pos. AMP MCP + 16 Pos. MQS (Micro Quadlok)

No. of Positions	Keying Options	Housing Color	Part Numbers			
			Receptacle Housing, 22 Positions	Receptacle Housing, 10 Positions	Cover and Lever	Mating PCB Header Right-Angle
22+16	–	Black	1534399-1	1534579-1	–	1534531-1

Unsealed AMP MCP 1.5K/2.8 Receptacle Housings

Technical Features

No. of Positions:

12 Position Assembly

Housing Material:

PA66 GF

Wire Size Range:

4x 2.5 mm² FLR Max.
8x 1.5 mm² FLR Max.

Extraction Tools:

Part No. **1579007-1**
Part No. **1-1579007-1**
dependent on the contact

Product Specification:

108-20243

Application Specification:

411-20071

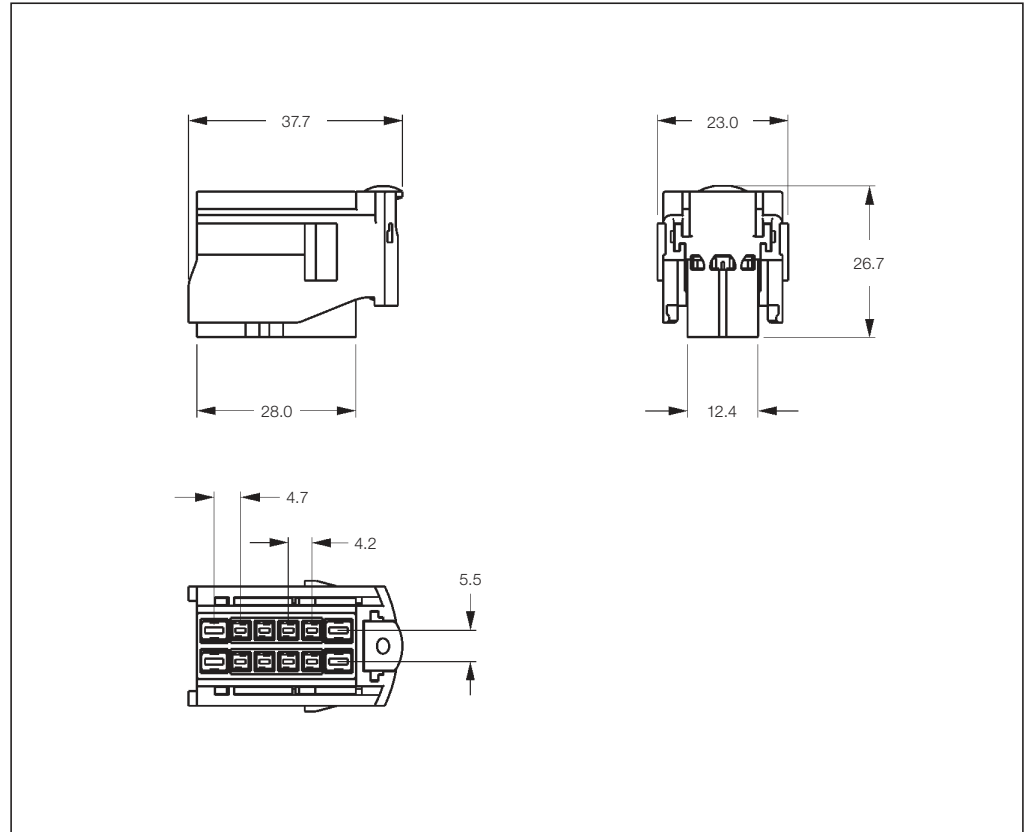

Unsealed Mixed Receptacle Housings

No. of Positions	Keying Options	Housing Color	Part Numbers			
			Receptacle Housing	Package Quantity	Mating Tab Housing	Mating PCB Header
12	A with CPA*	Black	284853-1	1,000	284858-1	-
	A without CPA	Black	284853-2	1,000	284858-3	-
	B with CPA*	Gray	284853-3	1,000	284858-2	-
	B without CPA	Gray	284853-4	1,000	284858-4	-

*) CPA = Connector Position Assurance.

Unsealed AMP MCP 1.5K/2.8 Receptacle Housings

Technical Features

No. of Positions:

20 Position Assembly

Housing Material:

PA66 GF

Wire Size Range:

4x 2.5 mm² FLR Max.
16x 1.5 mm² FLR Max.

Extraction Tools:

Part No. **1579007-1**
Part No. **1-1579007-1**
dependent on the contact

Product Specification:

108-20243

Application Specification:

411-20071

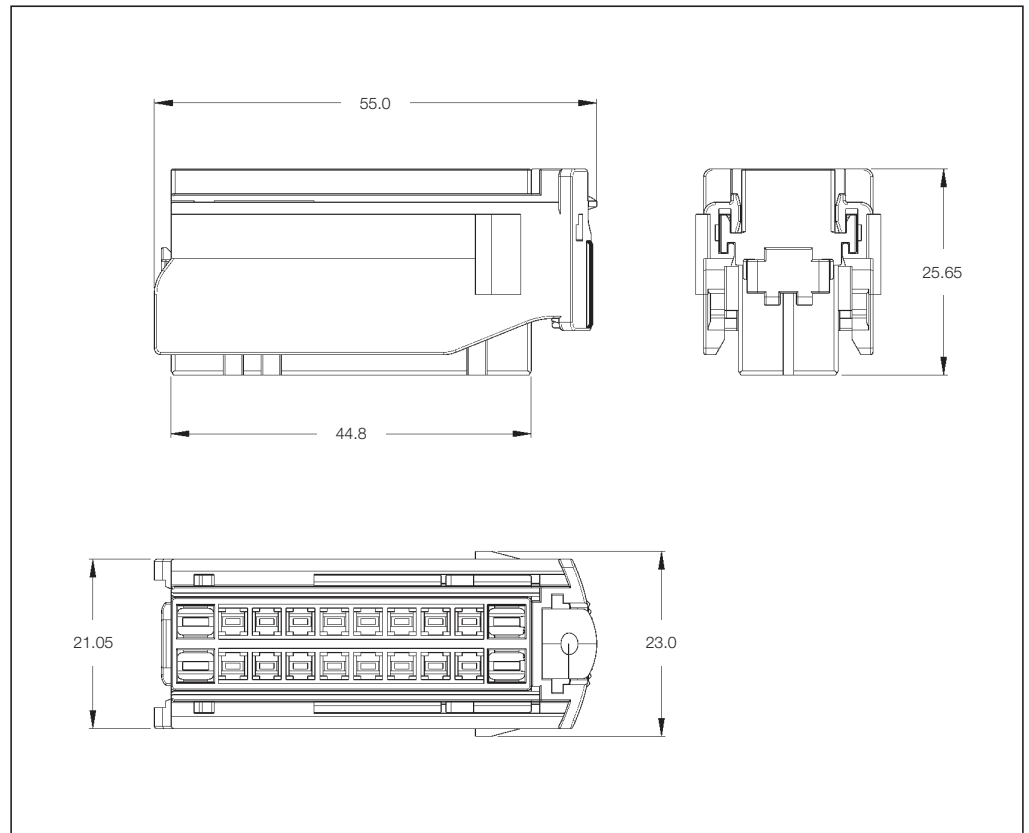

Unsealed Mixed Receptacle Housings

No. of Positions	Keying Options	Housing Color	Part Numbers			
			Receptacle Housing	Package Quantity	Mating Tab Housing	Mating PCB Header
20	A with CPA*	Black	284875-1	600	284879-1	-
	A without CPA	Black	284875-2	600	284879-3	-
	B with CPA*	Gray	284875-3	600	284879-2	-
	B without CPA	Gray	284875-4	600	284879-4	-

*) CPA = Connector Position Assurance.

Unsealed AMP MCP 1.5K Receptacle Insert

Technical Features

No. of Positions:
9 Positions

Housing Material:
PBT-GF20

Wire Size Range:
1.5 mm² FLR Max.

Product Specification:
108-18957

Application Specification:
114-18663

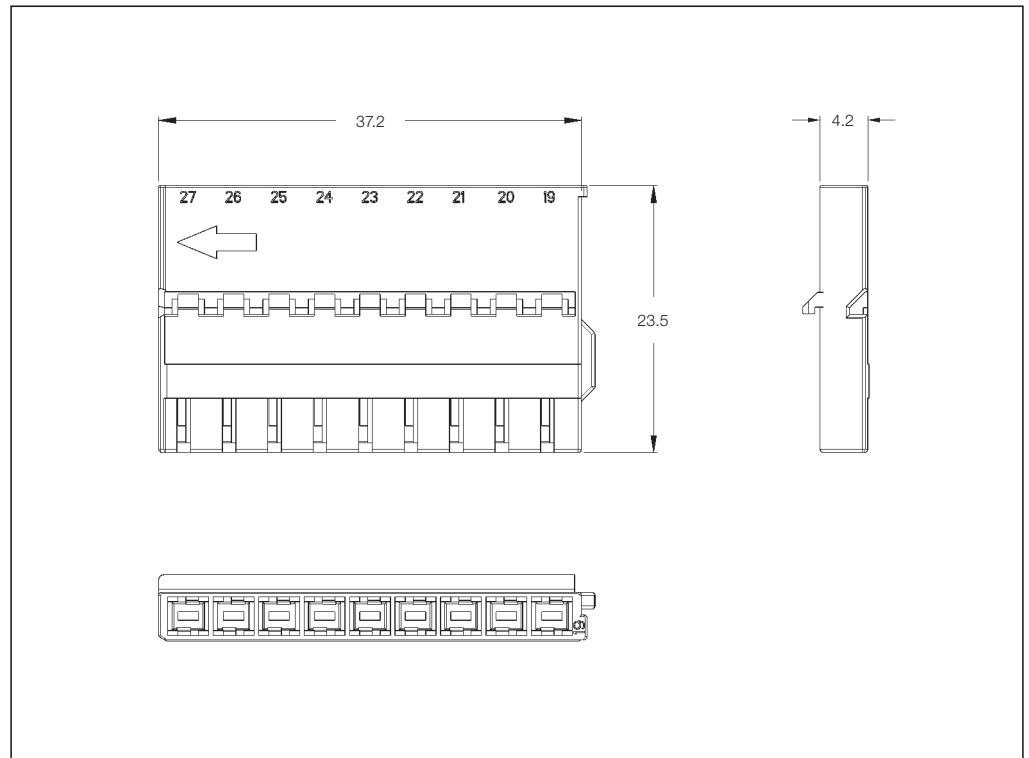

AMP MCP 1.5K Receptacle Insert

No. of Positions	Keying Options	Housing Color	Part Numbers	
			Receptacle Insert	Used with Carrier
9	A	Black	1718490-1	1-1718485-1
				1-1718485-2
	B	Natural	1718490-2	1-1718485-3
				1-1718485-4

Unsealed AMP MCP 1.5K Receptacle Insert

Technical Features

No. of Positions:

18 Positions

Housing Material:

PBT-GF20

Wire Size Range:

1.5 mm² FLR Max.

Product Specification:

108-18957

Application Specification:

114-18663

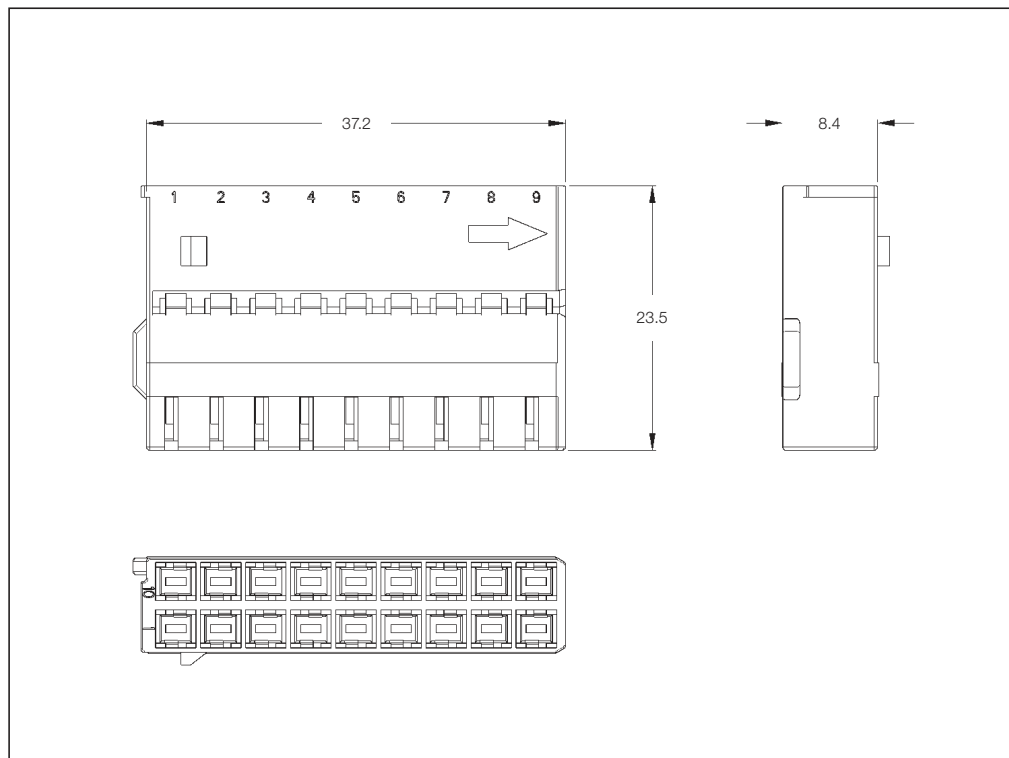

AMP MCP 1.5K Receptacle Insert

No. of Positions	Keying Options	Housing Color	Part Numbers	
			Receptacle Insert	Used with Carrier
18	-	Black	1718489-1	1-1718484-1
				1-1718484-2
				1-1718484-3
				1-1718484-4
				1-1718485-1
				1-1718485-2
				1-1718485-3
				1-1718485-4

Unsealed AMP MCP 2.8 Receptacle Insert

Technical Features

No. of Positions:
7 Positions

Housing Material:
PBT-GF20

Wire Size Range:
2.5 mm² FLR Max.

Product Specification:
108-18957

Application Specification:
114-18663

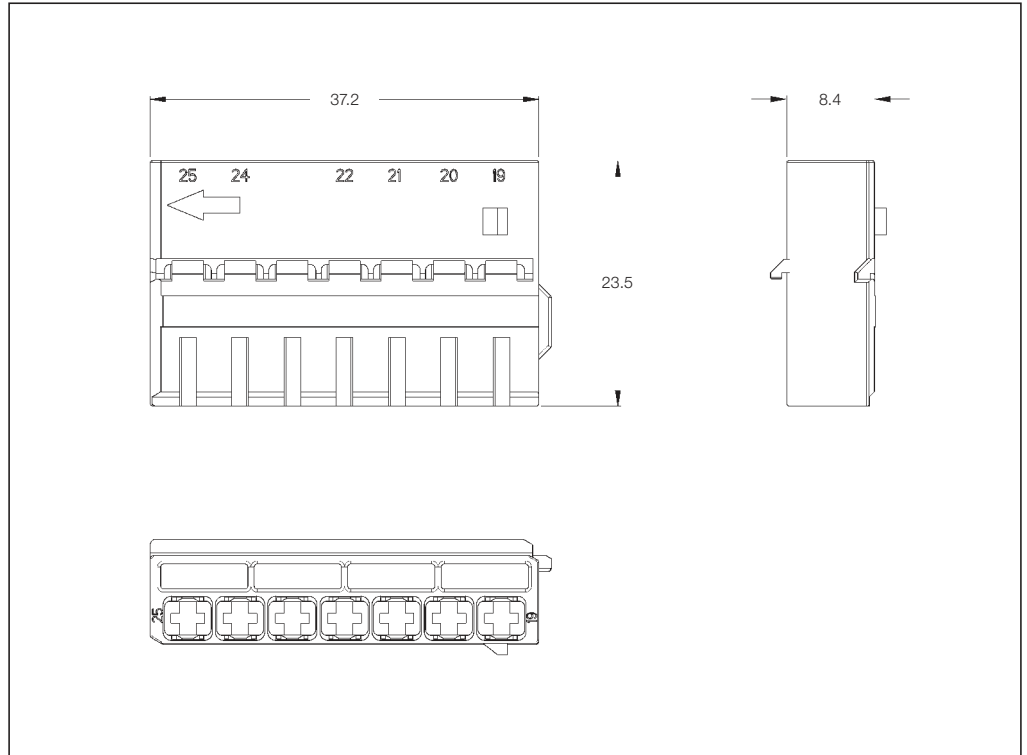

AMP MCP 2.8 Receptacle Insert

No. of Positions	Keying Options	Housing Color	Part Numbers	
			Receptacle Insert	Used with Carrier
7	-	Natural	1718488-1	1-1718484-1
				1-1718484-2
				1-1718484-3
				1-1718484-4

Unsealed (Carrier) Housings for AMP MCP 1.5K Receptacle Inserts

Technical Features

No. of Positions:

36 Positions

Housing Material:

PBT/ASA-GF30

Wire Size Range:

1.5 mm² FLR Max.
with receptacle insert
Part No. **1718489** and
Part No. **1718490**

Product Specification:

108-18957

Application Specification:

114-18663

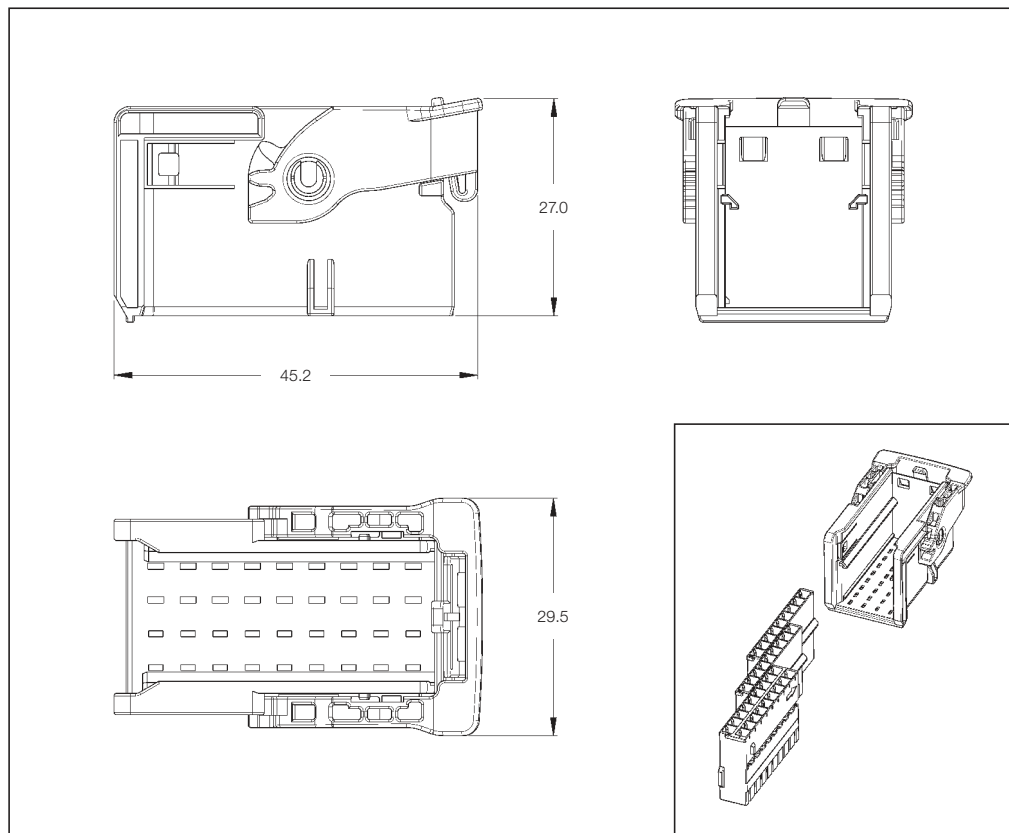

Unsealed (Carrier) Housings for AMP MCP 1.5K Receptacle Inserts

No. of Positions	Keying Options	Housing Color	Part Numbers					
			Carrier with Lever	9 Pos. Insert Key A	9 Pos. Insert Key B	18 Pos. Insert	Mating Tab Housing	Mating Tab Header
36	A	Fawn Brown	1-1718485-1				1-2112891-1	*)
	B	Traffic Purple	1-1718485-2	1718490-1	1718490-2	1718489-1	1-2112891-2	*)
	C	Emerald Green	1-1718485-3				1-2112891-3	*)
	D	Water Blue	1-1718485-4				1-2112891-4	*)

*) On request.

Unsealed (Carrier) Housings for AMP MCP 1.5K/AMP MCP 2.8 Receptacle Inserts

Technical Features

No. of Positions:

25 Positions

Housing Material:

PBT/ASA-GF30

Wire Size Range

(with Receptacle Insert):

Part No. **1718488-1**

2.5 mm² FLR Max. (7x)

Part No. **1718489-1**

1.5 mm² FLR Max. (18x)

Product Specification:

108-18957

Application Specification:

114-18663

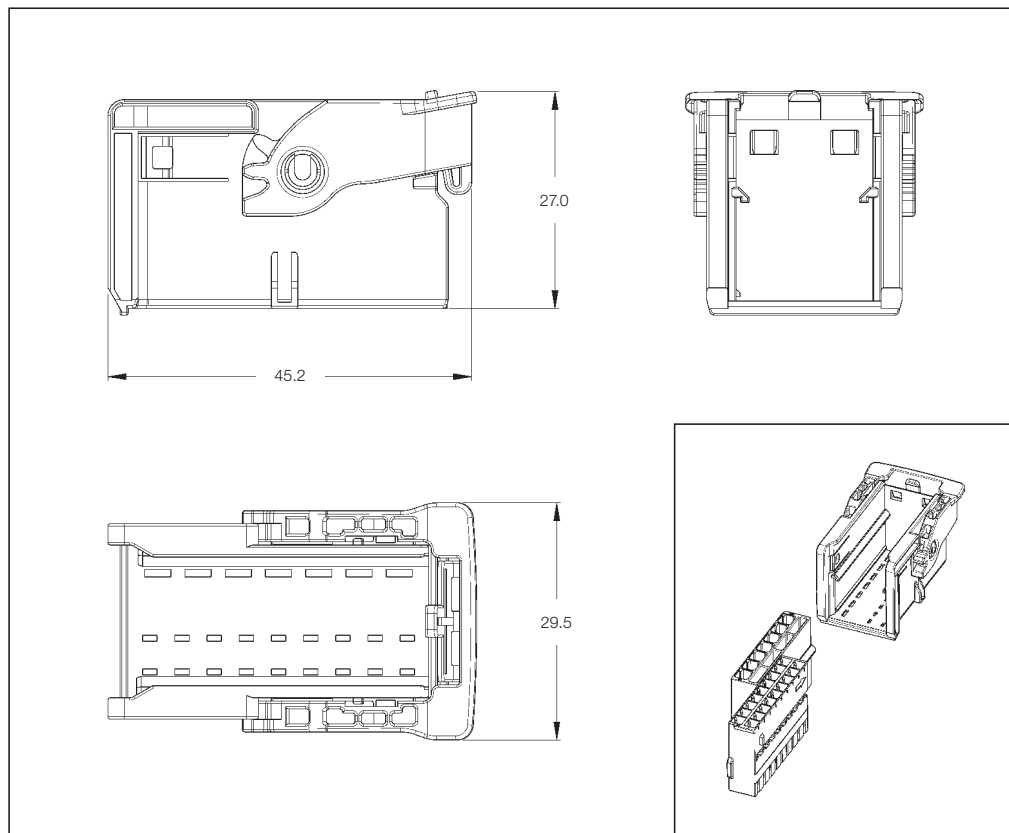

Unsealed (Carrier) Housings for AMP MCP 1.5K and AMP MCP 2.8 Receptacle Inserts

No. of Positions	Keying Options	Housing Color	Part Numbers				
			Carrier with Lever	7 Position Insert	18 Position Insert	Mating Tab Housing	Mating Tab Header
25	A	Black	1-1718484-1			1-2112890-1	*)
	B	Gray	1-1718484-2	1718488-1	1718489-1	1-2112890-2	*)
	C	Light Blue	1-1718484-3			1-2112890-3	*)
	D	Yellow Green	1-1718484-4			1-2112890-4	*)

*) On request.

Unsealed AMP MCP 2.8 Receptacle Housings with Secondary Locking

Technical Features

No. of Positions:
3–21 Positions

Housing Material:
PA66 GF13

Material and Finish Headers:
CuSn, tin plated

Wire Size Range:
2.5 mm² FLR Max.
4.0 mm² FLR Max. (3 Pos. only)

Product Group Drawing:
1355073 for 3–21 Positions

Product Specification:
108-18619-3

Application Specification:
114-18221-3

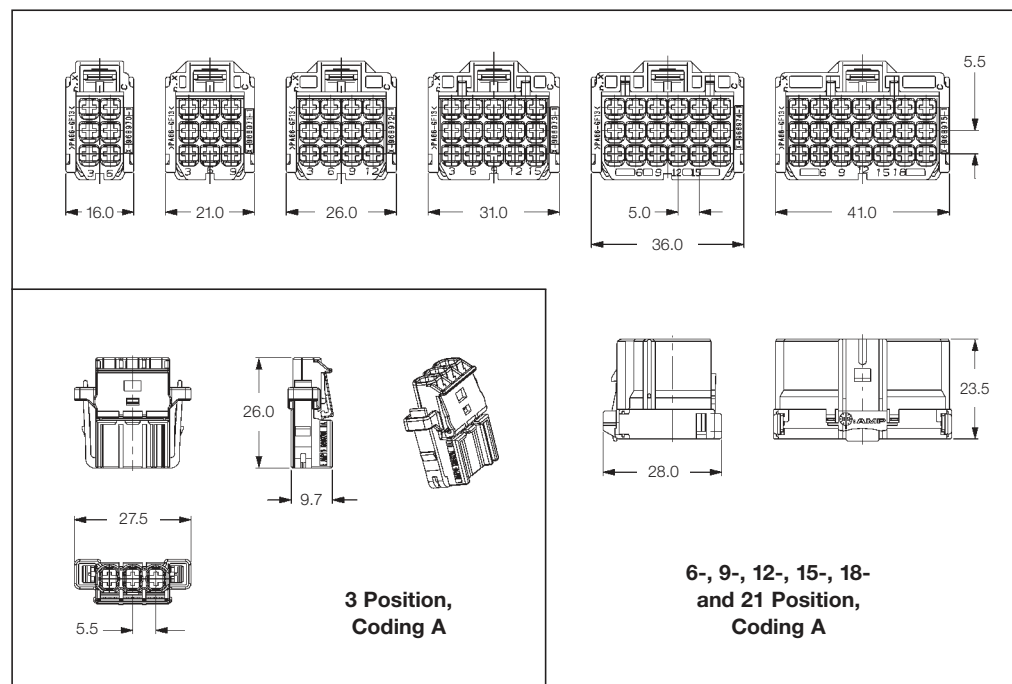

AMP MCP 2.8 Receptacle Housings with Secondary Locking

No. of Positions	Keying Options	Housing Color	Part Numbers			
			Receptacle Housing	Package Quantity	Mating Tab Housing	Mating PCB Header Right-Angle
3		Black	1-968976-9	1,000	1-968977-9	
6		Blue**	8-968970-1	2,400	1-965641-1*	
9		Yellow**	8-968971-1	1,000	1-967626-1*	
12	A	Green**	8-968972-1	1,500	1-967627-1*	
15		Violet**	8-968973-1	1,200	1-967628-1*	
18		Gray	8-968974-1	1,000	1-967629-1*	
21		Brown**	8-968975-1	900	1-967630-1*	
3		Gray	2-968976-9	1,000	2-968977-9	
6		Natural	7-968970-1	2,400	2-965641-1	
9		Natural	7-968971-1	1,800	2-967626-1	
12	B	Natural	7-968972-1	1,500	2-967627-1	6 Pos. 966140-5, Black
15		Natural	7-968973-1	1,200	2-967628-1	9 Pos. 966140-4, Black
18		Natural	7-968974-1	1,000	-	12 Pos. 966140-3, Black
21		Natural	7-968975-1	900	2-967630-1	15 Pos. 966140-2, Black
3		Blue	3-968976-9	1,000	3-968977-9	18 Pos. 966140-1, Black
6		Blue	6-968970-1	2,400	3-965641-1	21 Pos. 966140-6, Black
9		Blue	6-968971-1	1,800	3-967626-1	
12	C	Blue	6-968972-1	1,500	3-967627-1	
15		Blue	6-968973-1	1,200	3-967628-1	
18		Blue	6-968974-1	1,000	-	
21		Blue	6-968975-1	900	3-967630-1	
6		Violet	5-968970-1	2,400	4-965641-1	
9		Violet	5-968971-1	1,800	4-967626-1	
12	D	Violet	5-968972-1	1,500	4-967627-1	
15		Violet	5-968973-1	1,200	4-967628-1	
18		Violet	5-968974-1	1,000	-	

*) Other colors available. See Product Group Drawing 1355072.

**) Other colors available. See Product Group Drawing 1355073.

Unsealed AMP MCP 2.8 Receptacle Housings with Secondary Locking

Technical Features

No. of Positions:

4, 6, 10 and 14 Positions

Housing Material:

PBT-GF10

Wire Size Range:

4.0 mm² FLR Max.

Extraction Tool:

Part No. **929039-1**

Interface Drawing:

114-18792 – 4 Positions

114-18793 – 6 Positions

114-18795 – 10 Positions

114-18754 – 14 Positions

Product Specification:

108-94219

Application Specification:

—

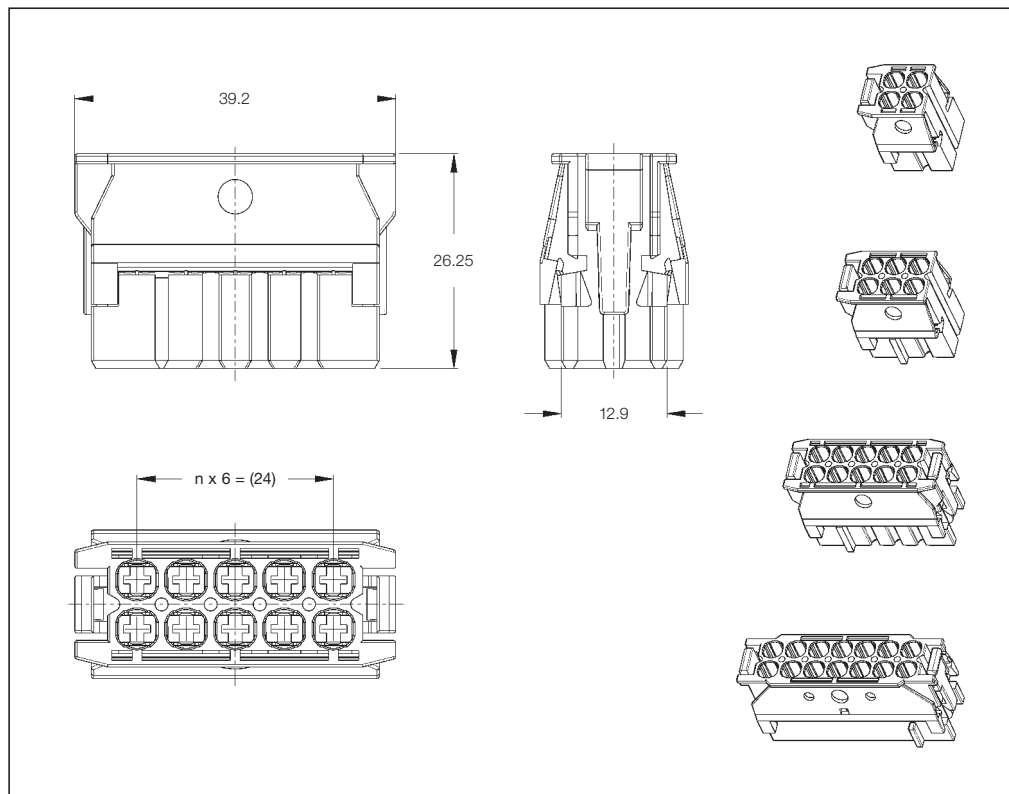

AMP MCP 2.8 Receptacle Housings with Secondary Locking

No. of Positions	Keying Options*	Housing Color*	Part Numbers			
			Receptacle Housing	Package Quantity	Mating Tab Housing	Mating PCB Header
4	A	Black	1-1670876-1	—		
6	A	Black	1-1670877-1	—		
10	B	Natural	2-1670879-1	—		
	C	Blue	3-1719844-1	—		
14	G	Orange	7-1719844-1	—		
	H	Pink	8-1719844-1	—		

*) Other Colors and Codings on request.

Unsealed AMP MCP 2.8 Receptacle Housings with Secondary Locking

Technical Features

Applications:

Connection to switch

No. of Positions:

10 Positions

Housing Material:

PA66 GF13

Material and Finish

Headers:

CuSn, tin plated

Wire Size Range:

2.5 mm² FLR Max.

Product Group Drawing:

1355073 for 3–21 Positions

Product Specification:

108-18619-3

Application Specification:

114-18221-3

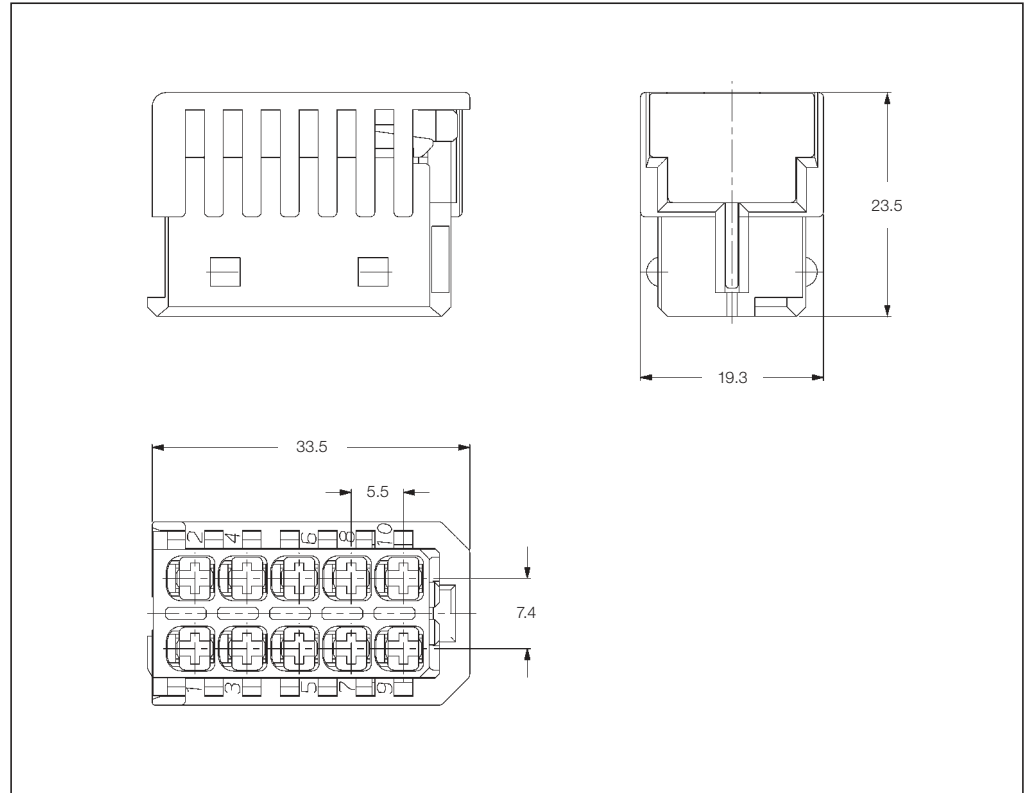

AMP MCP 2.8 Receptacle Housings with Secondary Locking

No. of Positions	Keying Options	Housing Color	Part Numbers			
			Receptacle Housing	Package Quantity	Mating Tab Housing	Mating PCB Header Right-Angle
10	A	Black	1418994-1	1,500	–	–

Unsealed AMP MCP 2.8 Receptacle Housings

Technical Features

Application:

Connection to tachograph

No. of Positions:

16 Positions (2 × 8)

Housing Material:

PA66 GF13

Wire Size Range:

2.5 mm² FLR Max.

Extraction Tool:

Part No. **1579007-1**

Product Group Drawing:

929092

Product Specification:

108-18619-3

Application Specification:

114-18221-3

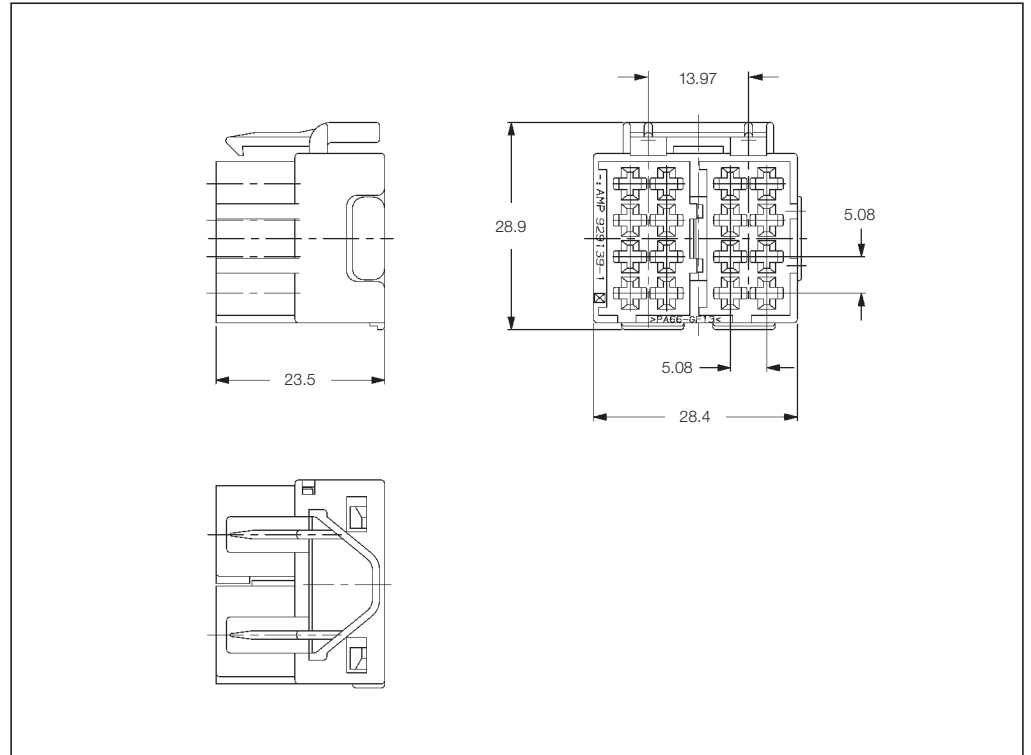

AMP MCP 2.8 Receptacle Housings

No. of Positions	Keying Options	Housing Color	Part Numbers			
			Receptacle Housing	Package Quantity	Mating Tab Housing	Mating PCB Header
2 x 8	-	Black	929092-1	1,000	-	-

Unsealed AMP MCP 6.3 Receptacle Housings with Secondary Locking

Technical Features

No. of Positions:
4 Positions

Housing Material:
PBT-GF10

Wire Size Range:
6.0 mm² FLR Max.

Extraction Tool:
Part No. **1-1579007-3**

Product Group Drawing:
1241438

Product Specification:
—

Application Specification:
—

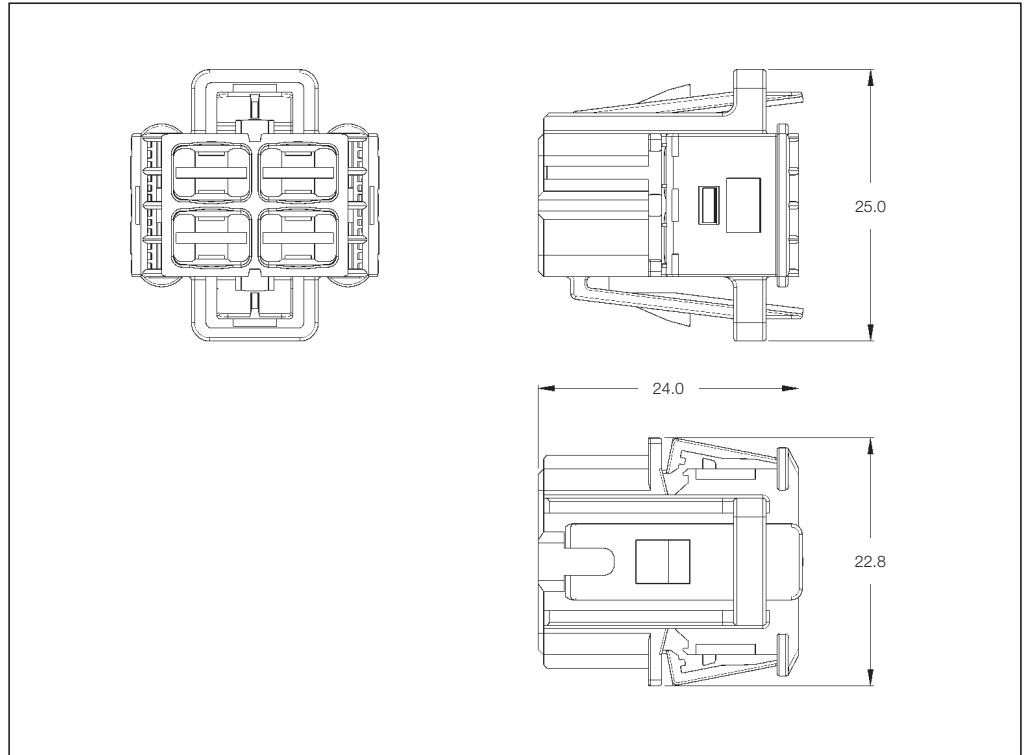

AMP MCP 6.3 Receptacle Housings with Secondary Locking

No. of Positions	Keying Options	Housing Color	Part Numbers			
			Receptacle Housing	Package Quantity	Mating Tab Housing	Mating PCB Header
4	A	Black	1534404-1	1,200	—	—
	B	Gray	1534404-2	1,200	—	—

Unsealed AMP MCP 9.5 Receptacle Housings with Secondary Locking

Technical Features

No. of Positions:

2 Positions

Housing Material:

PA66 GF13

Wire Size Range:

10.0 mm² FLK Max.

Extraction Tool:

Part No. **539971-1**

Product Specification:

—

Application Specification:

—

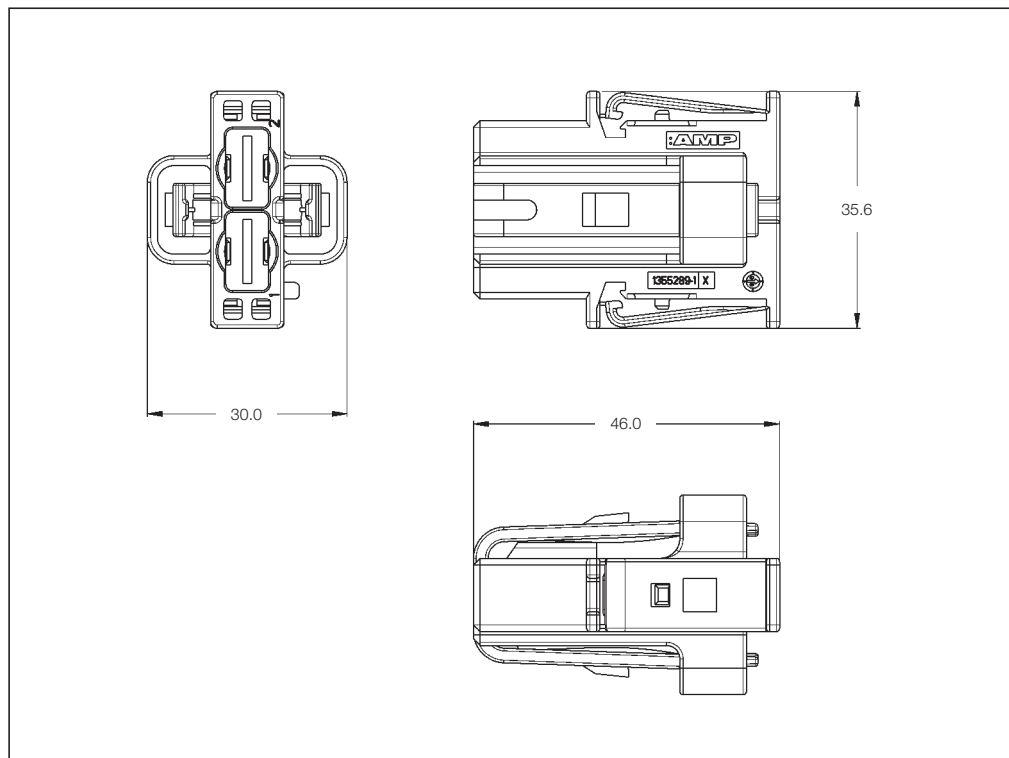

AMP MCP 9.5 Receptacle Housings with Secondary Locking

No. of Positions	Keying Options	Housing Color	Part Numbers			
			Receptacle Housing	Package Quantity	Mating Tab Housing	Mating PCB Header
2	A	Black	1355289-1	800	1355290-1	—
	B	Gray	1355289-2	800	—	—
	C	Blue	1355289-3	800	—	—
	D	Yellow/Green	1355289-4	800	—	—

Unsealed 1.5 mm/2.8 mm Tab Housings

Technical Features

No. of Positions:

12 Position Assembly

Housing Material:

PA66 GF

Wire Size Range:

4x 2.5 mm² FLR Max.
8x 1.5 mm² FLR Max.

Extraction Tools:

Part No. **539960-1**
Part No. **1-1579007-6**
dependent on the contact

Product Specification:

108-20243

Application Specification:

411-20071

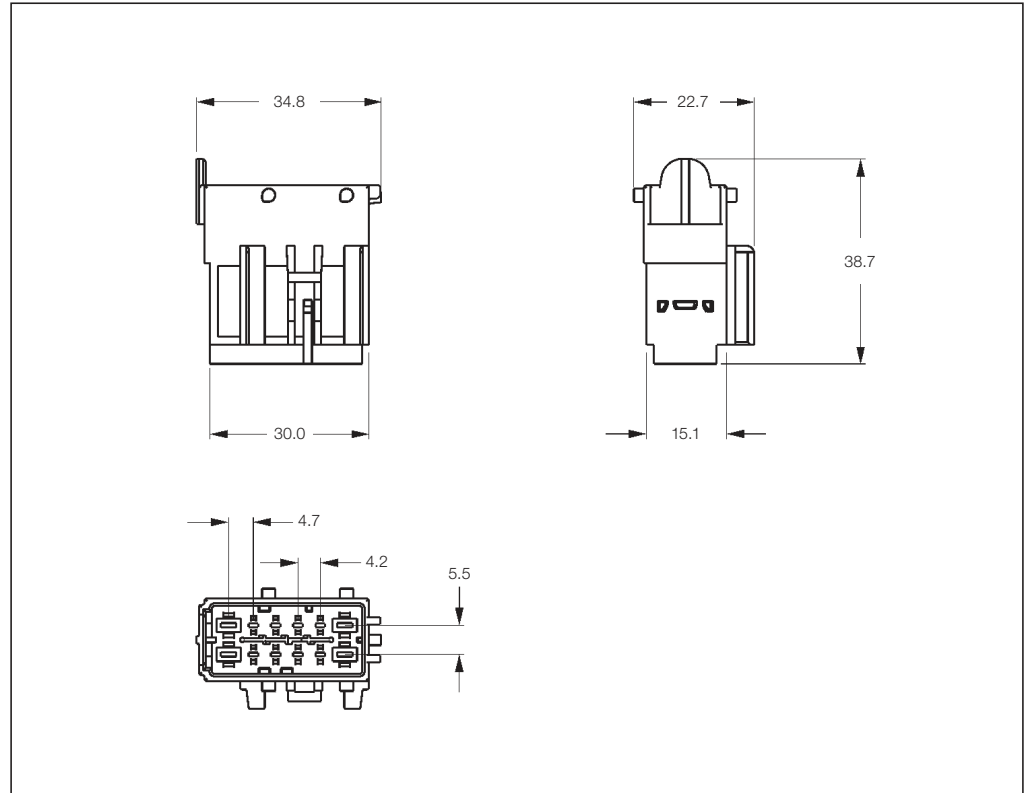

Unsealed Tab Housings

No. of Positions	Keying Options	Housing Color	Part Numbers			
			Tab Housing	Package Quantity	Mating Receptacle Housing	Mating PCB Header
12	A Panel Hook on Left Side	Black	284858-1	900	284853-1	-
	A Panel Hook on Right Side	Black	284858-3	900	284853-2	-
	B Panel Hook on Left Side	Gray	284858-2	900	284853-3	-
	B Panel Hook on Right Side	Gray	284858-4	900	284853-4	-

Unsealed 1.5 mm/2.8 mm Tab Housings

Technical Features

No. of Positions:

20 Position Assembly

Housing Material:

PA66 GF

Wire Size Range:

4x 2.5 mm² FLR Max.
16x 1.5 mm² FLR Max.

Extraction Tools:

Part No. **539960-1**
Part No. **1-1579007-6**
dependent on the contact

Product Specification:

108-20243

Application Specification:

411-20071

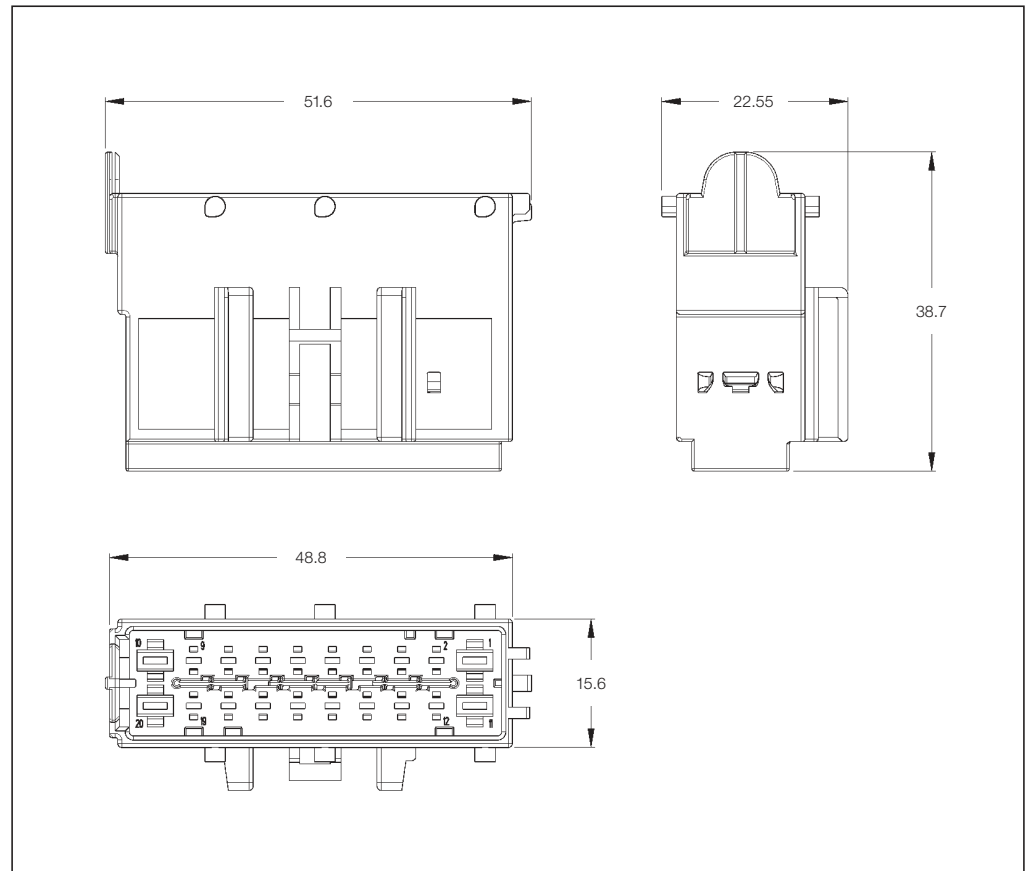

Unsealed Tab Housings

No. of Positions	Keying Options	Housing Color	Part Numbers			
			Tab Housing	Package Quantity	Mating Receptacle Housing	Mating PCB Header
20	A Panel Hook on Left Side	Black	284879-1	450	284875-1	-
	A Panel Hook on Right Side	Black	284879-3	450	284875-2	-
	B Panel Hook on Left Side	Gray	284879-2	450	284875-3	-
	B Panel Hook on Right Side	Gray	284879-4	450	284875-4	-

Unsealed 1.5 mm/2.8 mm Tab Housings

Technical Features

No. of Positions:
25 Positions

Housing Material:
PBT-GF10

Wire Size Range:
7x 2.5 mm² FLR Max.
18x 1.5 mm² FLR Max.

Extraction Tools:
Part No. **1-1579007-1**
Part No. **1-1579007-2**
dependent on the contact

Product Specification:
108-18957

Application Specification:
114-18663

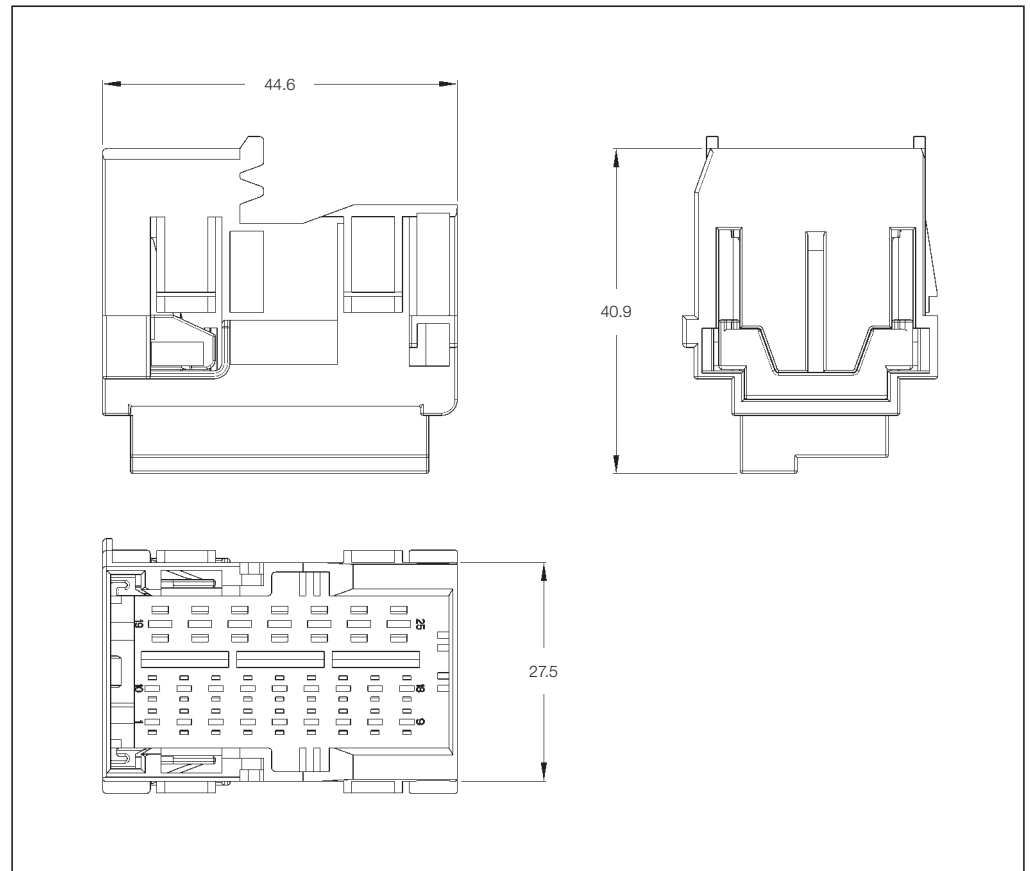

Unsealed Tab Housings

No. of Positions	Keying Options	Housing Color	Part Numbers			
			Tab Housing	Carrier with Lever	7 Position Insert	18 Position Insert
25	A	Black	1-2112890-1	1-1718484-1	1718488-1	1718489-1
	B	Gray	1-2112890-2	1-1718484-2		
	C	Light Blue	1-2112890-3	1-1718484-3		
	D	Yellow Green	1-2112890-4	1-1718484-4		

Unsealed 1.5 mm Tab Housings

Technical Features

No. of Positions:
36 Positions

Housing Material:
PBT-GF10

Wire Size Range:
1.5 mm² FLR Max.

Extraction Tools:
Part No. **1-1579007-1**
Part No. **1-1579007-2**
dependent on the contact

Product Specification:
108-18957

Application Specification:
114-18663

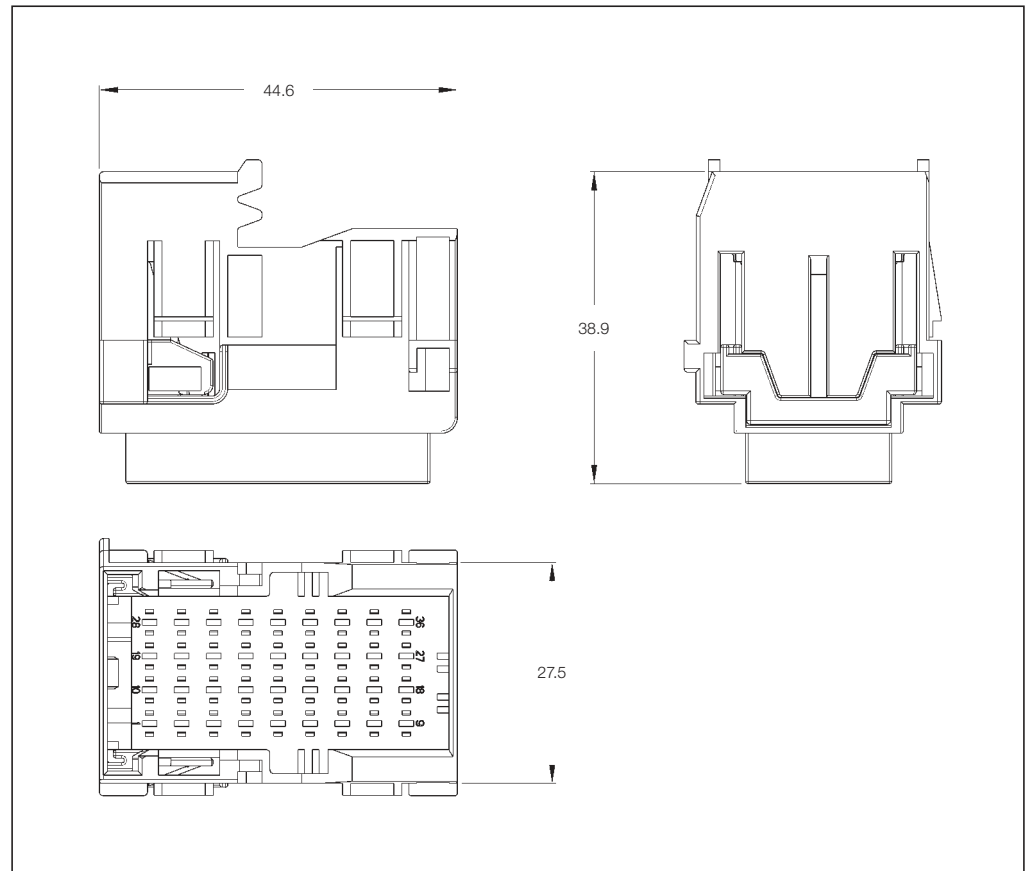

Unsealed Tab Housings

No. of Positions	Keying Options	Housing Color	Part Numbers				
			Tab Housing	Carrier with Lever	Mating		
					9 Pos. Insert Key A	9 Pos. Insert Key B	18 Position Insert
36	A	Brown	1-2112891-1	1-1718484-1	1718490-1	1718490-2	1718489-1
	B	Purple	1-2112891-2	1-1718484-2			
	C	Emerald Green	1-2112891-3	1-1718484-3			
	D	Water Blue	1-2112891-4	1-1718484-4			

Unsealed 2.8 mm Tab Housings with Optional Secondary Locking

Technical Features

No. of Positions:
3–21 Positions

Housing Material:
PA66 GF13

Locking Device:
PBT ASA-GF30

Wire Size Range:
2.5 mm² FLR Max.

Product Group Drawing:
1355072 for 6–21 Positions

Product Specification:
108-18619-3

Application Specification:
114-18051

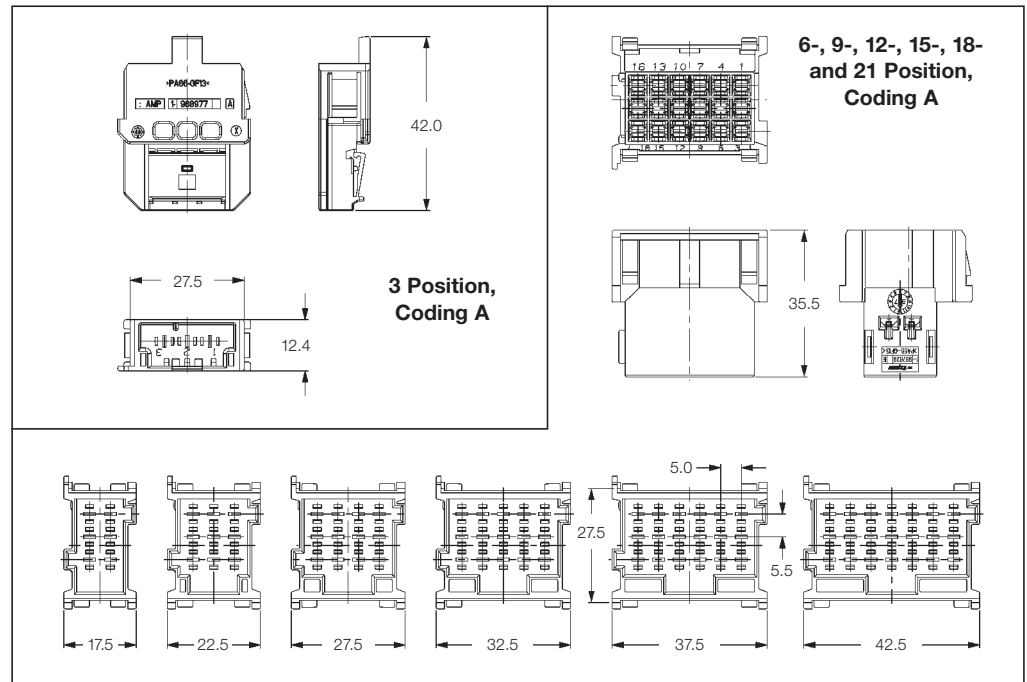

Unsealed 2.8 mm Tab Housings with Optional Secondary Locking

No. of Positions	Keying Options	Housing Color	Part Numbers				
			Tab Housing	Package Quantity	Secondary Locking Device	Package Quantity	Mating Receptacle Housing
3		Black	1-968977-9	1,500			1-968976-9
6		Blue	1-965641-1 *	1,500			8-968970-1
9		Yellow	1-967626-1 *	1,100			8-968971-1
12	A	Green	1-967627-1 *	950	6 Position Blue: 968271-1	7,500	8-968972-1
15		Violet	1-967628-1 *	800			8-968973-1
18		Gray	1-967629-1 *	700			8-968974-1
21		Brown	1-967630-1 *	600			8-968975-1
3		Gray	2-968977-9	1,500	9 Position Yellow: 967631-1	3,000	2-968976-9
6		Natural	2-965641-1	1,500			7-968970-1
9		Natural	2-967626-1	1,100			7-968971-1
12	B	Natural	2-967627-1	950	12 Position Green: 967632-1	5,000	7-968972-1
15		Natural	2-967628-1	800			7-968973-1
18		Natural	-	-			7-968974-1
21		Natural	2-967630-1	600			7-968975-1
3		Blue	3-968977-9	1,500	15 Position Violet: 967633-1	3,000	3-968976-9
6		Blue	3-965641-1	1,500			6-968970-1
9		Blue	3-967626-1	1,100			6-968971-1
12	C	Blue	3-967627-1	950	18 Position Gray: 967634-1	2,500	6-968972-1
15		Blue	3-967628-1	800			6-968973-1
18		Blue	-	-			6-968974-1
21		Blue	3-967630-1	600			6-968975-1
6		Violet	4-965641-1	1,500	21 Position Brown: 967635-1	2,500	5-968970-1
9		Violet	4-967626-1	1,100			5-968971-1
12	D	Violet	4-967627-1	950			5-968972-1
15		Violet	4-967628-1	800		5-968973-1	
18		Violet	-	-			5-968974-1

*) Other colors available. See Product Group Drawing 1355072.

Unsealed 2.8 mm Tab Housings for Potential Distribution for Wall or Panel Mounting

Technical Features

No. of Positions:

21 Pos. on One Electrical Level
2 x 9 Pos. on Two Electrical Levels

Housing Material:

PBT-GF10

Material and Finish:

CuSn4, tin plated

Product Specification:

108-18879

Application Specification:

—

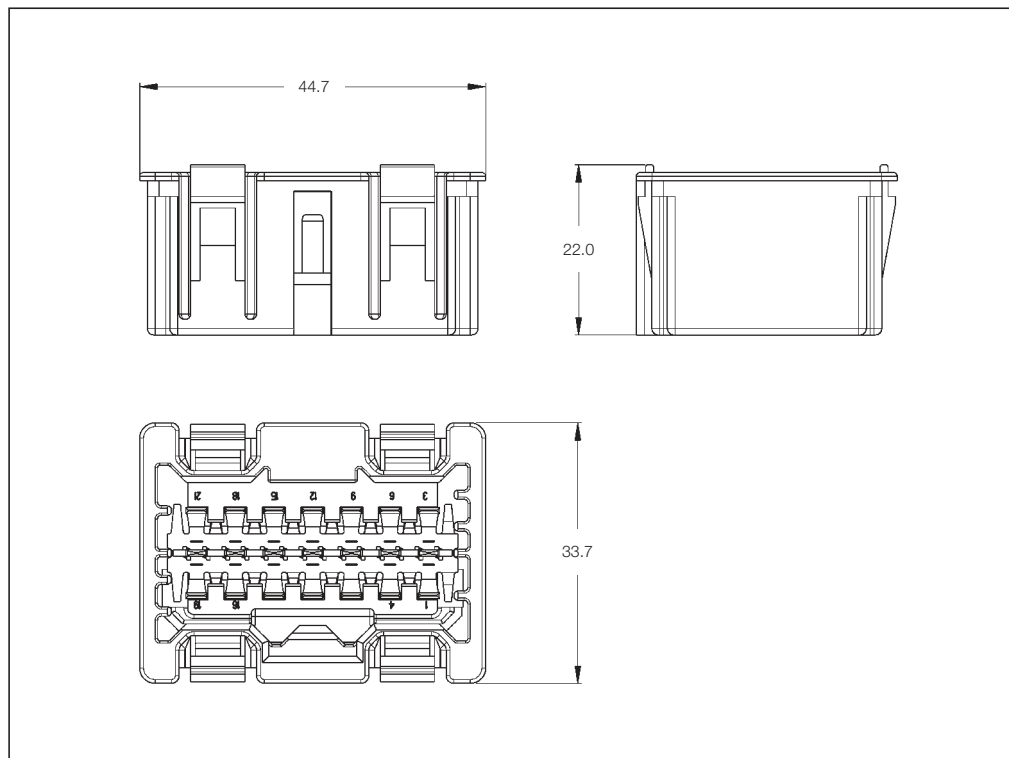

Unsealed 2.8 mm Tab Housings for Potential Distribution for Wall or Panel Mounting

No. of Positions	Keying Options	Housing Color	Part Numbers			
			Tab Housing	Package Quantity	Mating Receptacle Housing	Mating PCB Header
21	A	Brown	1-1394765-1	462	8-968975-1	—
	B	Natural	2-1394765-1	462	7-968975-1	—
2 x 9	B	Natural	2-1394766-1	462	7-968975-1	—
	C	Blue	3-1394766-1	462	6-968975-1	—
2 x 9 120 Ω	C	Blue	3-1394766-2	462	6-968975-1	—

Unsealed 2.8 mm Tab Housings for Potential Distribution for Wall or Panel Mounting

Technical Features

No. of Positions:
21 Pos. on One Electrical Level

Housing Material:
PBT-GF10

Material and Finish:
CuSn4, tin plated

Product Specification:
108-18879

Application Specification:
—

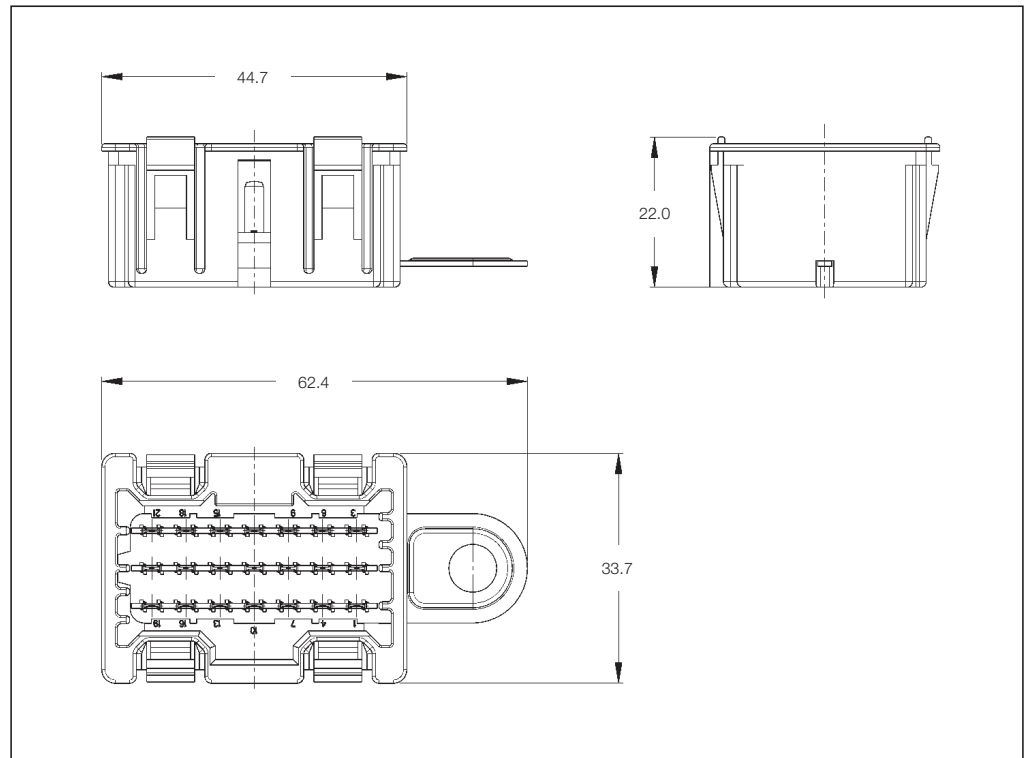

Unsealed 2.8 mm Tab Housings for Potential Distribution for Wall or Panel Mounting

No. of Positions	Keying Options	Housing Color	Part Numbers			
			Tab Housing	Package Quantity	Mating Receptacle Housing	Mating PCB Header
21	A	Brown	1534188-1	330	8-968975-1	—

Unsealed 9.5 mm Tab Housings with Secondary Locking

Technical Features

No. of Positions:
2 Positions

Housing Material:
PA66 GF13

Wire Size Range:
10.0 mm² FLK Max.

Extraction Tool:
Part No. **1-1579007-7**

Product Specification:
—

Application Specification:
—

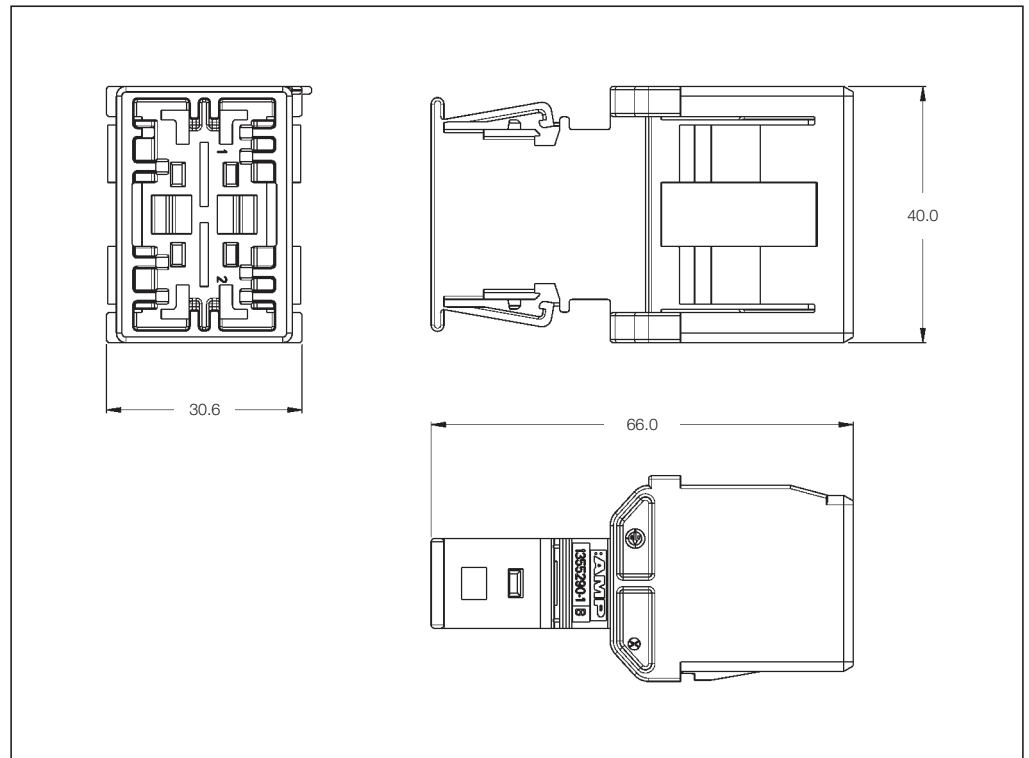

Unsealed 9.5 mm Tab Housings with Secondary Locking

No. of Positions	Keying Options	Housing Color	Part Numbers			
			Tab Housing	Package Quantity	Mating Receptacle Housing	Mating PCB Header
2	A	Black	1355290-1	350	1355289-1	—
	B	Gray	*)	—	1355289-2	—
	C	Blue	*)	—	1355289-3	—
	D	Yellow/Green	*)	—	1355289-4	—

*) On request.

Unsealed 1.5 mm Housings – PCB Headers

Technical Features

No. of Positions:
32 Positions

Housing Material:
PBT-GF20

Material and Finish:
CuSn4, tin plated

Product Specification:
108-18950

Application Specification:
114-18619-001

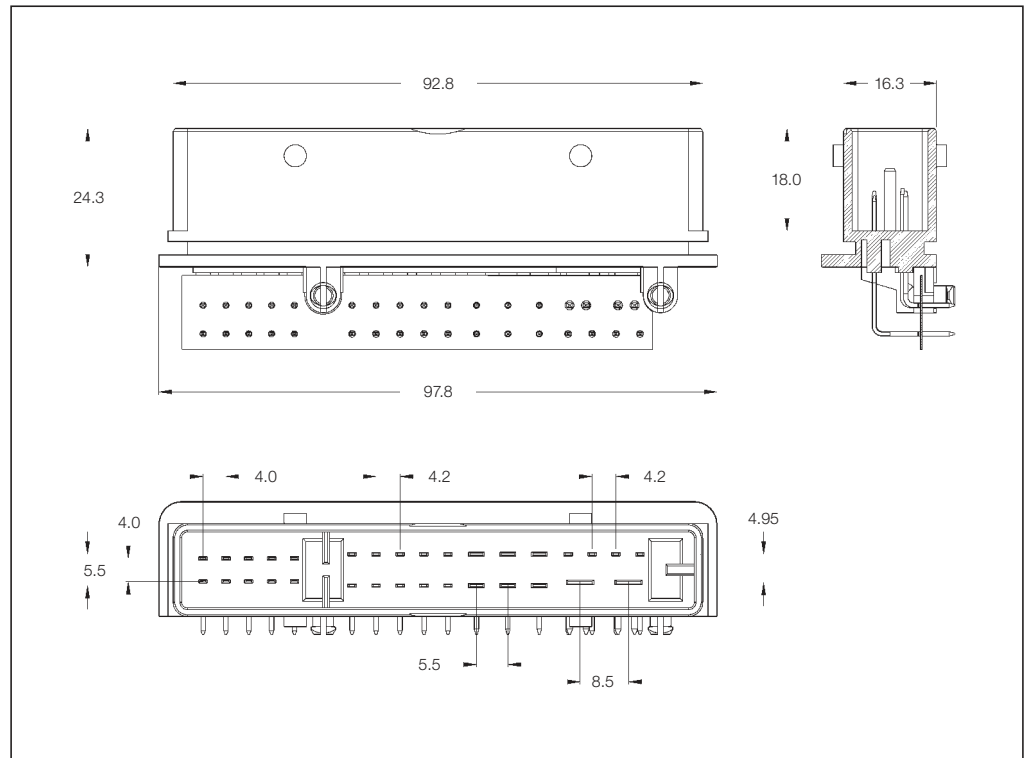

32 Position PCB Headers

No. of Positions	Keying Options	Housing Color	Part Numbers	
			PCB Header Right-Angle	Mating Receptacle Housing
32	A	Black	1534046-1	1534180
				1534181
				1534399

Unsealed 1.5 mm Housings – PCB Headers

Technical Features

No. of Positions:
38 Positions

Housing Material:
PBT-GF20

Material and Finish:
CuSn4, tin plated
CuFe4, tin plated

Product Specification:
—

Application Specification:
—

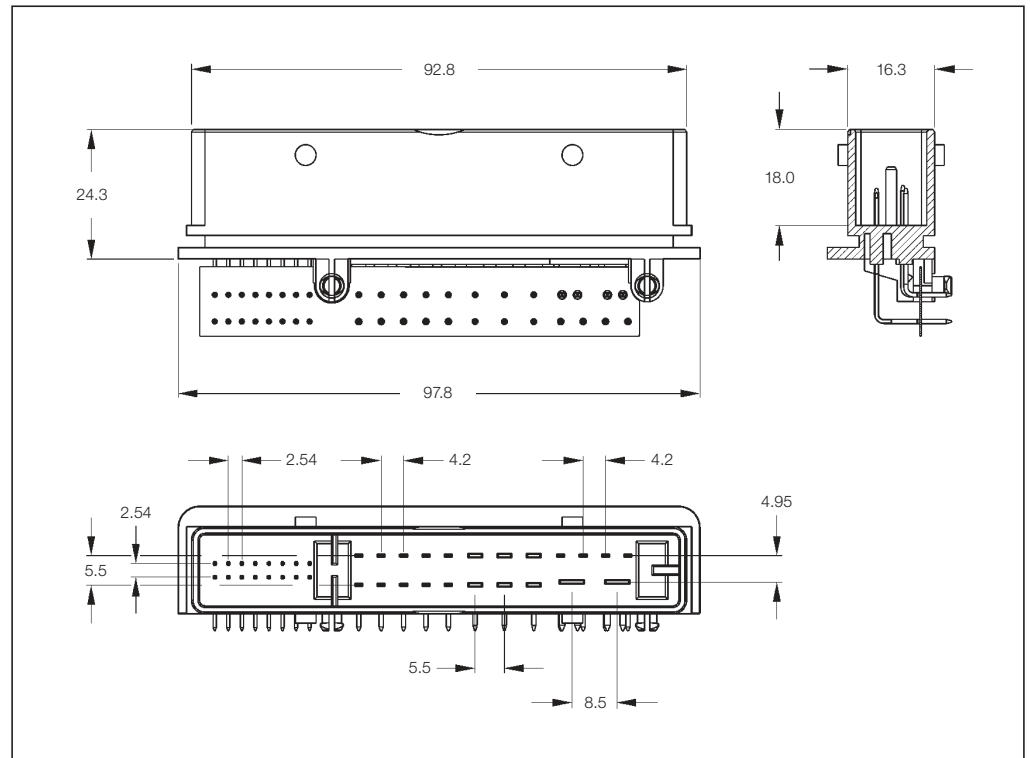

38 Position PCB Headers

No. of Positions	Keying Options	Housing Color	Part Numbers	
			PCB Header Right-Angle	Mating Receptacle Housing
38	A	Black	1534531-1	1534180
				1534579
				1534399

Unsealed 2.8 mm Housings – Vertical PCB Headers

Technical Features

No. of Positions:
 6–21 Positions

Housing Material:
 PA66 GF13

Material and Finish Headers:
 CuSn4, tin plated
 (silver plated on request)

Wire Size Range:
 2.5 mm² FLR Max.

Product Group Drawing:
 966140

Product Specification:
 108-18619-3

Application Specification:
 114-18051

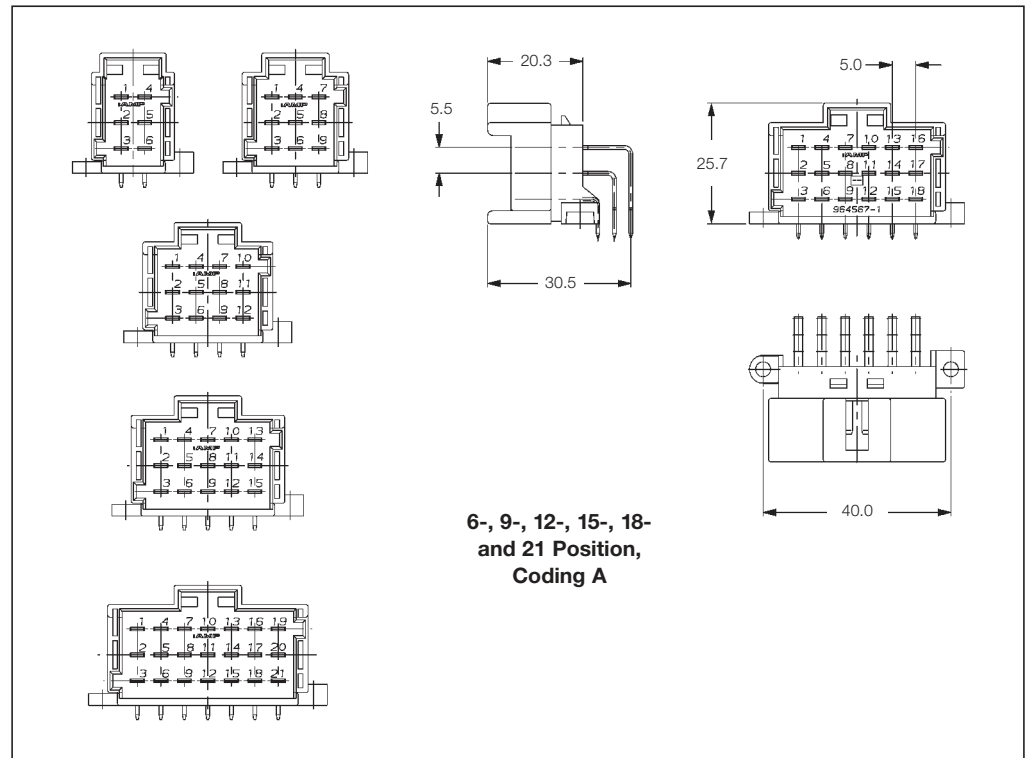

Unsealed 2.8 mm Housings – PCB Headers

No. of Positions	Housing Color*	Part Numbers		
		Mating Right-Angle PCB Header	Package Quantity	Mating Receptacle Housing
				8-968970-1
		Packed in plastic anti-static tray and corrugated box		8-968971-1
				8-968972-1
				8-968973-1
				8-968974-1
6		966140-5		8-968975-1
9		966140-4	168	7-968970-1
12	Black	966140-3**		7-968971-1
15		966140-2		7-968972-1
18		966140-1	112	7-968973-1
21		966140-6**		7-968974-1
				7-968975-1
		Packed in non anti-static tray and corrugated box		6-968970-1
				6-968971-1
				6-968972-1
				6-968973-1
6		9-966140-5		6-968974-1
9		9-966140-4	168	6-968975-1
12	Black	9-966140-3**		5-968970-1
15		9-966140-2		5-968971-1
18		9-966140-1	112	5-968972-1
21		9-966140-6**		5-968973-1

*) Silver plated on request.
 **) Other codings available. See Product Group Drawing 966140.

Unsealed 2.8 mm Housings – PCB Headers

Technical Features

No. of Positions:
18 Positions

Housing Material:
PA66 GF13

Material and Finish:
Part No. **967116-1**
CuSn, tin plated
Part No. **967116-2**
Mating Area: Silver plated
Solder Area: Tin plated

Product Specification:
108-18619-3

Application Specification:
—

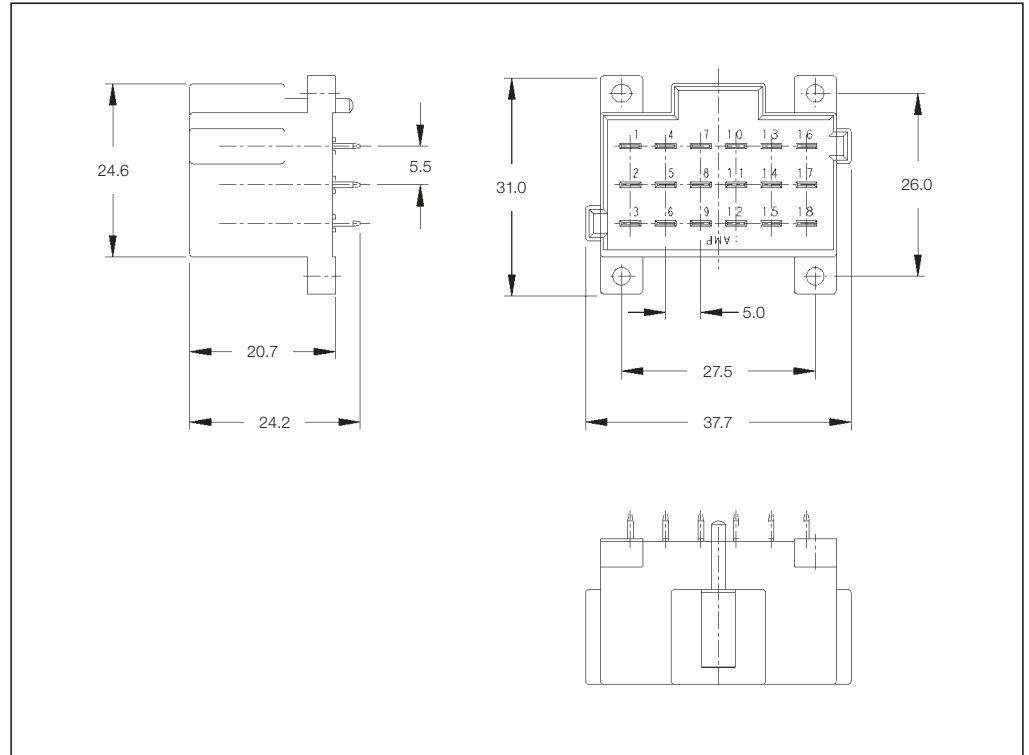

Unsealed 2.8 mm Housings – PCB Headers

No. of Positions	Housing Color	Part Numbers		
		Vertical PCB Header	Package Quantity	Mating Receptacle Housing
18	Black	967116-1	450	—
		967116-2		

Sealed AMP MCP 1.5K/2.8 Receptacle Housings

Technical Features

No. of Positions:

12 Positions

Housing Material:

PA66 GF

Wire Size Range:

4x 2.5 mm² FLR Max.
8x 1.0 mm² FLR Max.

Extraction Tools:

Part No. **1579007-1**
Part No. **1-1579007-1**
dependent on the contact

Product Specification:

108-20242

Application Specification:

411-20073

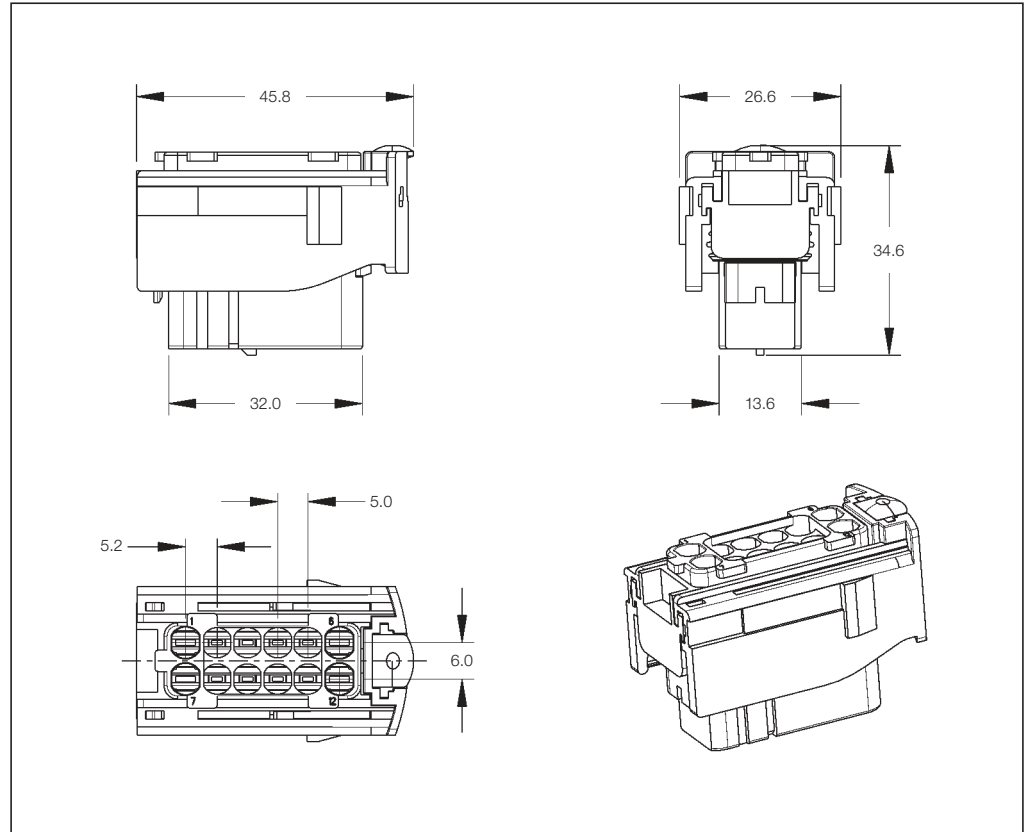

Sealed Mixed Receptacle Housings

No. of Positions	Keying Options	Housing Color	Part Numbers			
			Receptacle Housing	Package Quantity	Mating Tab Housing	Mating PCB Header
12	A with CPA*	Black	284848-1	500	284844-1 & 284844-3 1745045-1	-
	A without CPA	Black	284848-3	500	284844-1 & 284844-3	-
	B with CPA*	Gray	284848-2	500	284844-2	-
	B without CPA	Gray	284848-4	500	284844-4	-

*) CPA = Connector Position Assurance.

Sealed AMP MCP 1.5K/2.8 Receptacle Housings

Technical Features

No. of Positions:

20–24 Positions

Housing Material:

PA66 GF

Wire Size Range:

8x 2.5 mm² FLR Max.
16x 1.0 mm² FLR Max.

Extraction Tools:

Part No. **1579007-1**

Part No. **1-1579007-1**
dependent on the contact

Product Specification:

108-20262

Application Specification:

411-20100

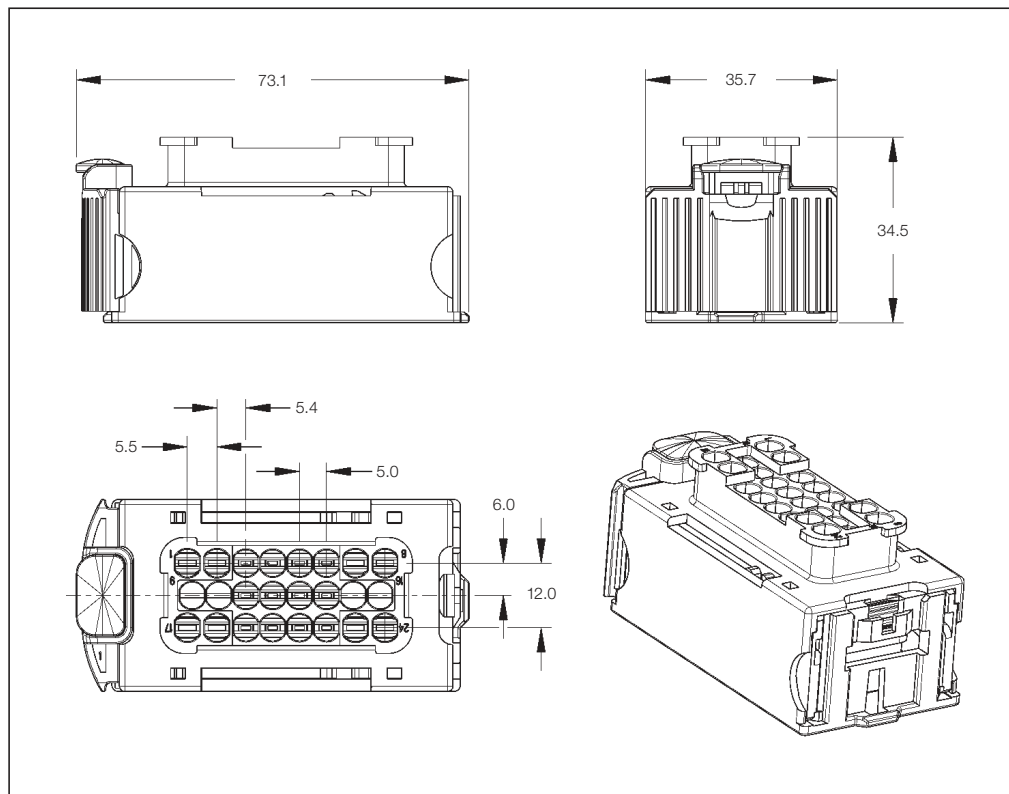

Sealed Mixed Receptacle Housings

No. of Positions	Keying Options	Housing Color	Part Numbers				
			Receptacle Housing	Package Quantity	Cover	Mating Tab Housing	Mating PCB Header
20	A (Slide Right)	Black	1745043-1	320	–	1745044-1	–
	A (Slide Left)	Black	1745043-2	320	–	–	–
24	A (Slide Right)	Gray	1745043-3	320	–	1745044-2	–
	A (Slide Left)	Gray	1745043-4	320	–	–	–

Sealed AMP MCP 2.8 Receptacle Housings

Technical Features

No. of Positions:

2 Positions

Housing Material:

PA66 GF13

Wire Size Range:

2.5 mm² FLR Max.

Extraction Tool:

Part No. **1579007-1**
dependent on the contact

Product Specification:

108-18699-1 (Rec. Housing)

Application Specification:

114-18148-1 (Rec. Housing)

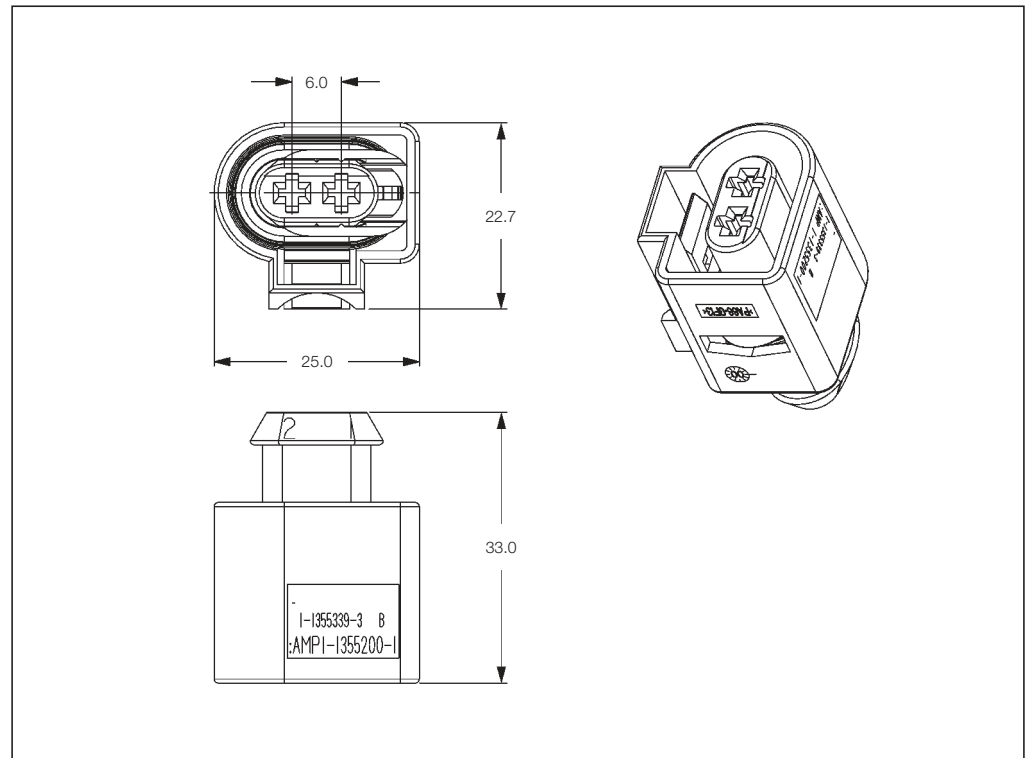

Sealed Receptacle Housings

No. of Positions	Keying Options	Housing Color	Part Numbers			
			Receptacle Housing	Package Quantity	Mating Tab Housing	Mating PCB Header
2	A	Black	1-1355200-1	800	1-966867-1	–
	B	Natural	2-1355200-1	800	1-966867-2	–
		Black	2-1355200-2	800	1-966867-2	–

Sealed AMP MCP 2.8 Receptacle Housings

Technical Features

No. of Positions:
2, 3, 4 and 5 Positions

Housing Material:
PA66 GF30

Wire Size Range:
2.5 mm² FLR Max.

Extraction Tool:
Part No. **929039-1**

Interface Drawing:
114-18251-011

Product Specification:
108-18981

Application Specification:
—

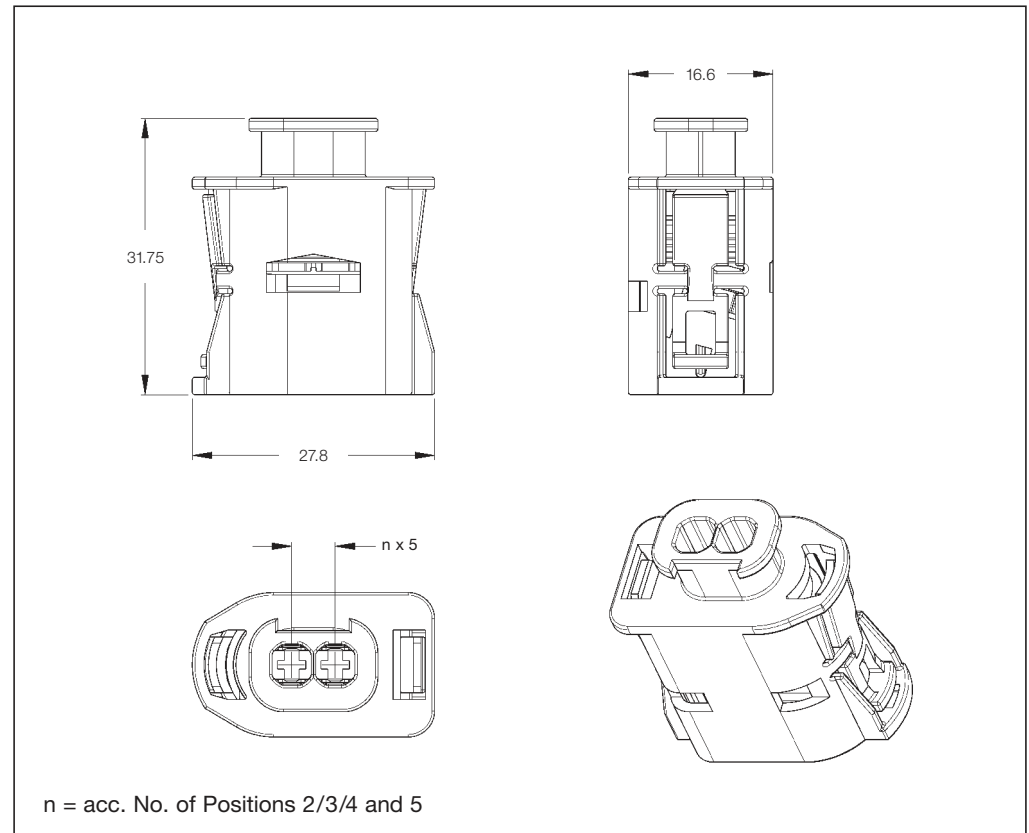

Sealed Receptacle Housings

No. of Positions	Keying Options*	Housing Color*	Part Numbers			
			Receptacle Housing	Package Quantity	Mating Tab Housing	Mating PCB Header
2	A	Black	1-1718626-1	1,000		
3	A	Black	1-1718627-1	800		
4	A	Black	1-1718628-1	700	—	—
5	A	Black	1-1718629-1	—		

*) Other Colors and Codings on request.

Sealed AMP MCP 2.8 Receptacle Housings

Technical Features

No. of Positions:
4–6 Positions

Housing Material:
PBT-GF

Wire Size Range:
2.5 mm² FLR Max.

Product Specification:
108-20274

Application Specification:
—

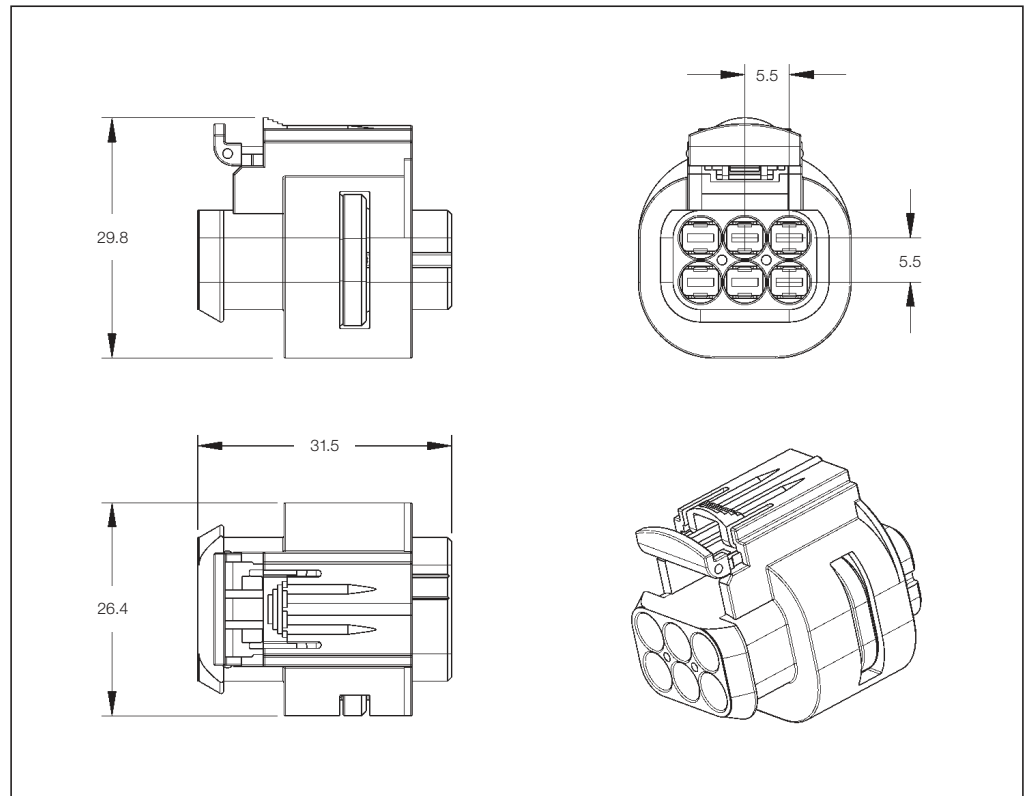

Sealed Receptacle Housings

No. of Positions	Keying Options	Housing Color	Part Numbers				
			Receptacle Housing	Package Quantity	Cover	Mating Tab Housing	Mating PCB Header
6	A	Gray	1745078-1	400	—	—	—
4	A	Black	1745078-2	400	—	—	—

Sealed AMP MCP 2.8 Receptacle Housings

Technical Features

No. of Positions:

9 Positions

Housing Material:

PBT-GF

Wire Size Range:

2.5 mm² FLR Max.

Product Specification:

108-15403

Application Specification:

411-15726

Interface Specification:

1801318

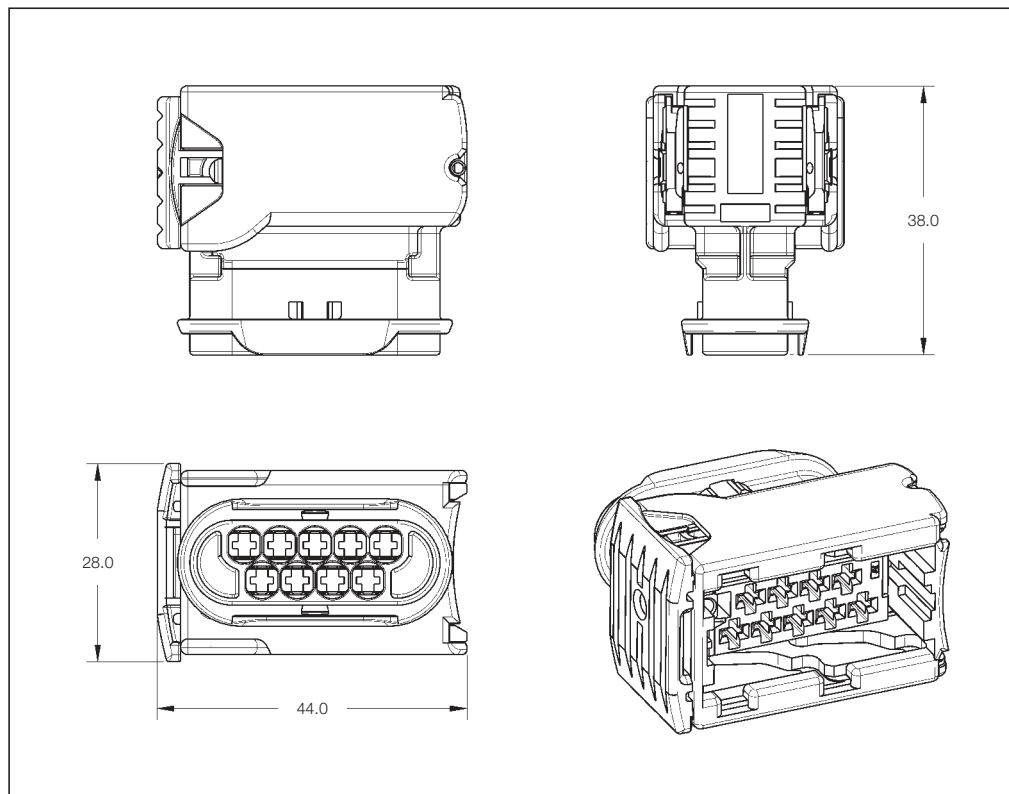

Sealed Receptacle Housings

No. of Positions	Keying Options	Housing Color	Part Numbers				
			Receptacle Housing	Package Quantity	Cover	Mating Tab Housing	Mating PCB Header
9	-	Black	1801286-1	500	953717-1	1534238-1	-
		Gray	1801286-3	500			
		Purple	1801286-6	-			

Sealed AMP MCP 2.8 Receptacle Housings

Technical Features

No. of Positions:
15 Positions

Housing Material:
PBT-GF

Wire Size Range:
2.5 mm² FLR Max.

Product Specification:
108-15403

Application Specification:
411-15726

Interface Specification:
1801287

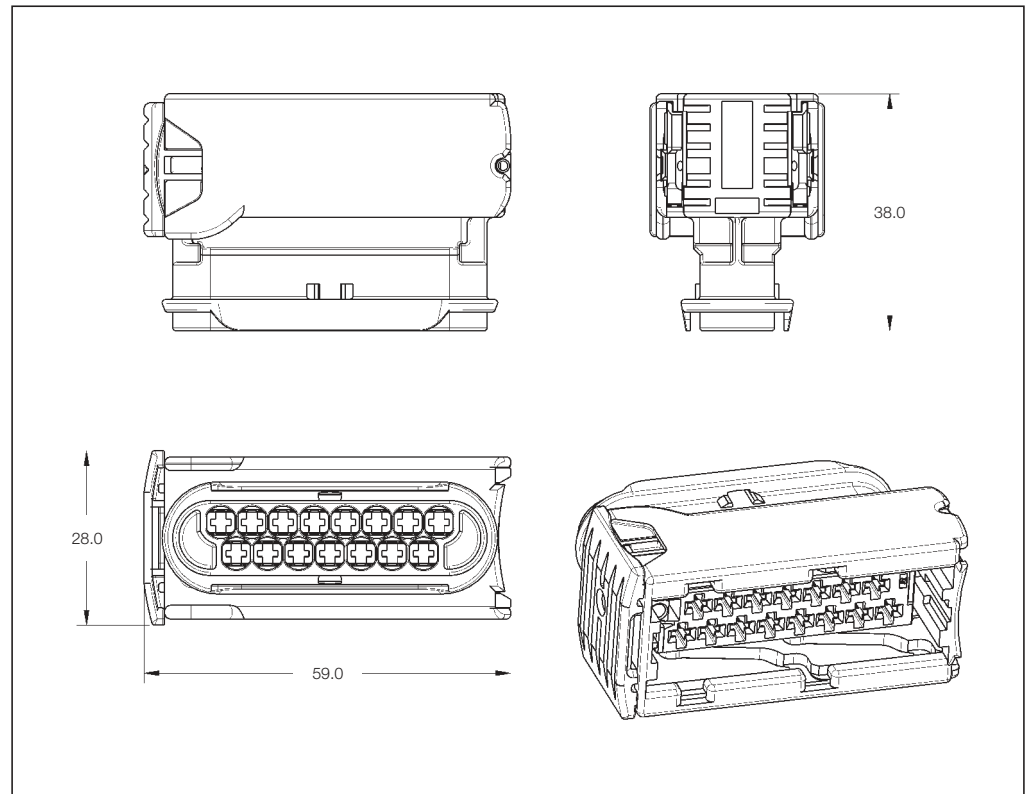

Sealed Receptacle Housings

No. of Positions	Keying Options	Housing Color	Part Numbers				
			Receptacle Housing	Package Quantity	Cover	Mating Tab Housing	Mating PCB Header
15	-	Black	1801326-1	300			
		Gray	1801326-3	300			
		Green	1801326-4	-	-	-	-
		Brown	1801326-5	300			
		Purple	1801326-6	300			

Sealed AMP MCP 2.8 Receptacle Housings

Technical Features

No. of Positions:
10 Positions

Housing Material:
PBT-GF

Wire Size Range:
2.5 mm² FLR Max.

Product Specification:
108-18923

Application Specification:
114-18631

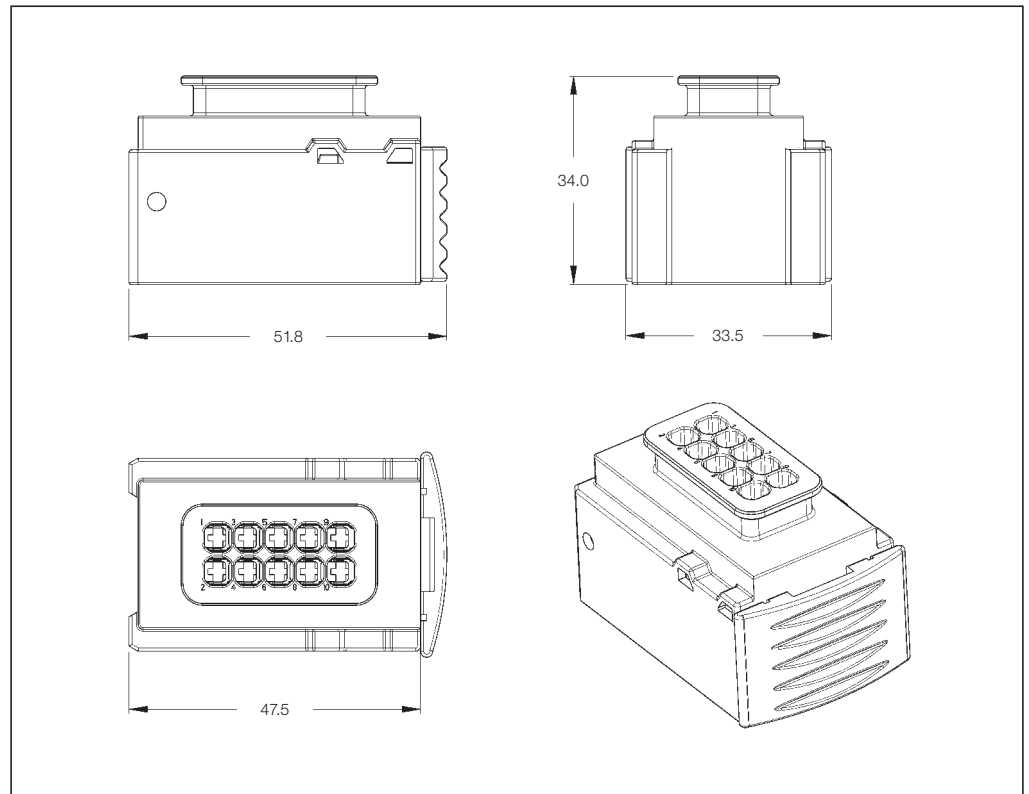

Sealed Receptacle Housings

No. of Positions	Keying Options	Housing Color	Part Numbers				
			Receptacle Housing	Package Quantity	Cover	Mating Tab Housing	Mating PCB Header
10	A	Black	1718156-1	280	1718495-1	-	-
	B	Gray	1718156-2	280			

Sealed AMP MCP 2.8 Receptacle Housings

Technical Features

No. of Positions:
16 Positions

Housing Material:
PBT-GF

Wire Size Range:
2.5 mm² FLR Max.

Product Specification:
108-18923

Application Specification:
114-18631

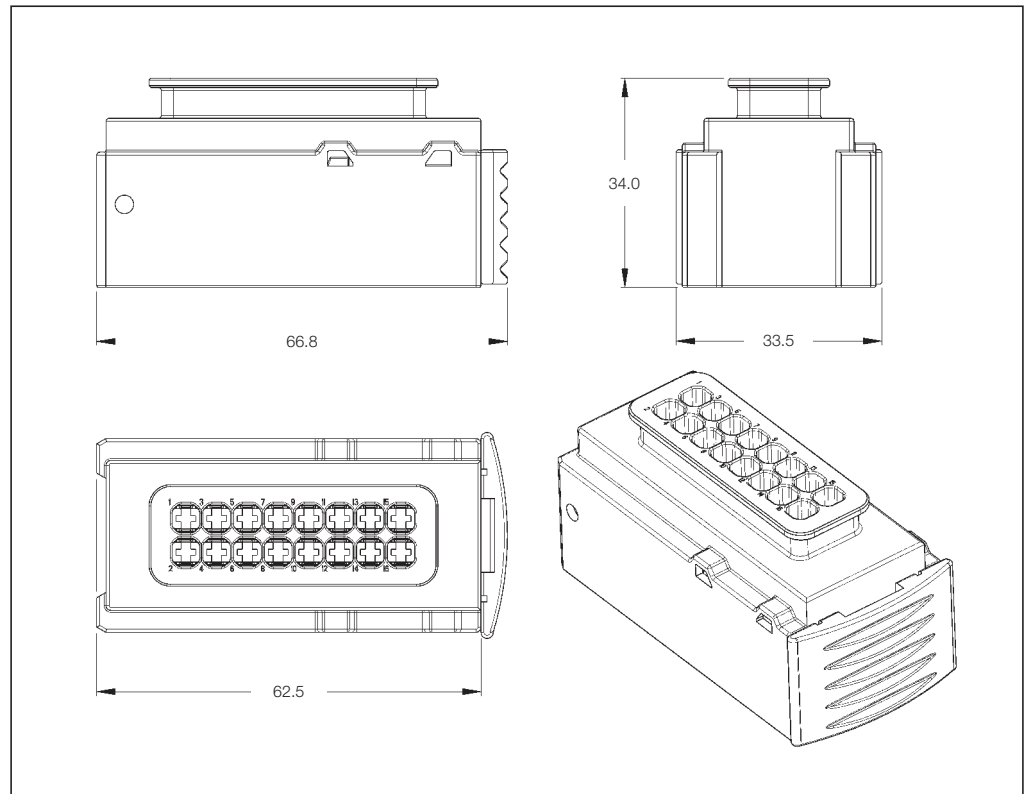

Sealed Receptacle Housings

No. of Positions	Keying Options	Housing Color	Part Numbers				
			Receptacle Housing	Package Quantity	Cover	Mating Tab Housing	Mating PCB Header
16	A	Black	1718149-1	220	1718155-1	-	-
	B	Gray	1718149-2	220			

Sealed AMP MCP 9.5 Receptacle Housings

Technical Features

No. of Positions:

1 Position

Housing Material:

PA66 GF15

Wire Size Range:

16.0 mm² FLK Max.

Extraction Tool:

Part No. **539971-1**

Product Specification:

—

Application Specification:

—

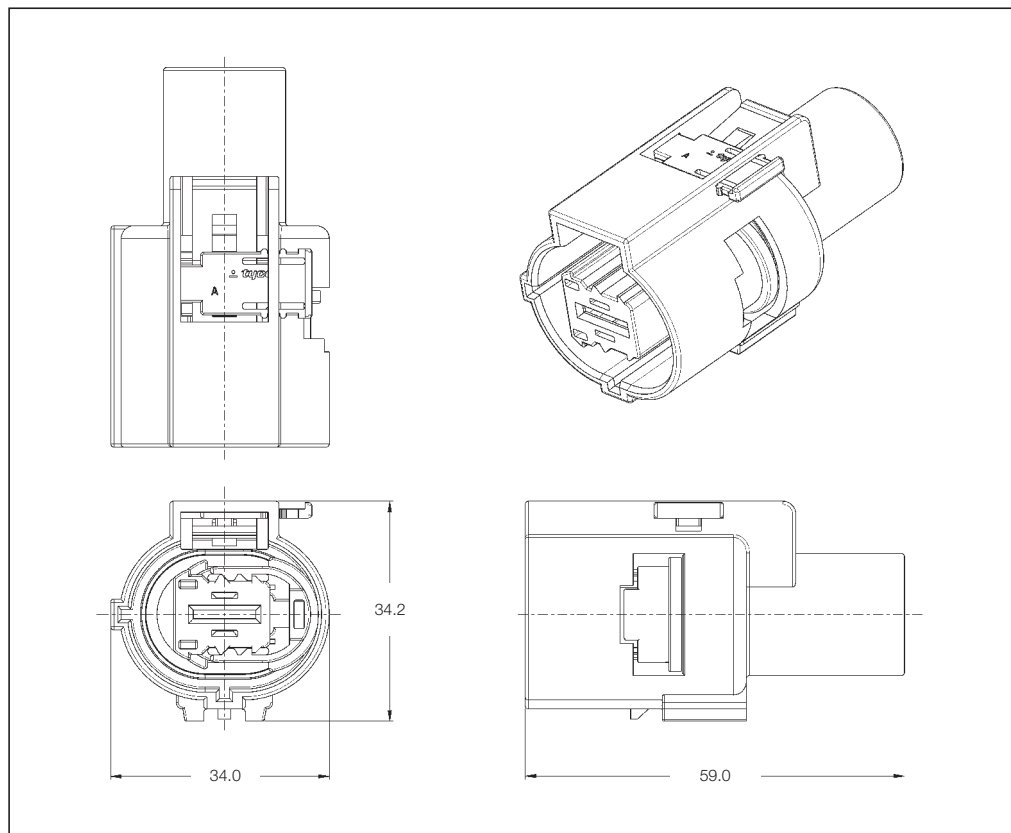

Sealed Receptacle Housings

No. of Positions	Keying Options	Housing Color	Part Numbers			
			Receptacle Housing	Package Quantity	Mating Tab Housing	Mating PCB Header
1	—	Black	1743793-1	40	1743797-1	—

Sealed AMP MCP 9.5 Receptacle Housings

Technical Features

No. of Positions:
2 Positions

Housing Material:
PA66 GF13

Wire Size Range:
16.0 mm² FLK Max.

Extraction Tool:
Part No. **539971-1**

Product Specification:
108-18809

Application Specification:
114-18501

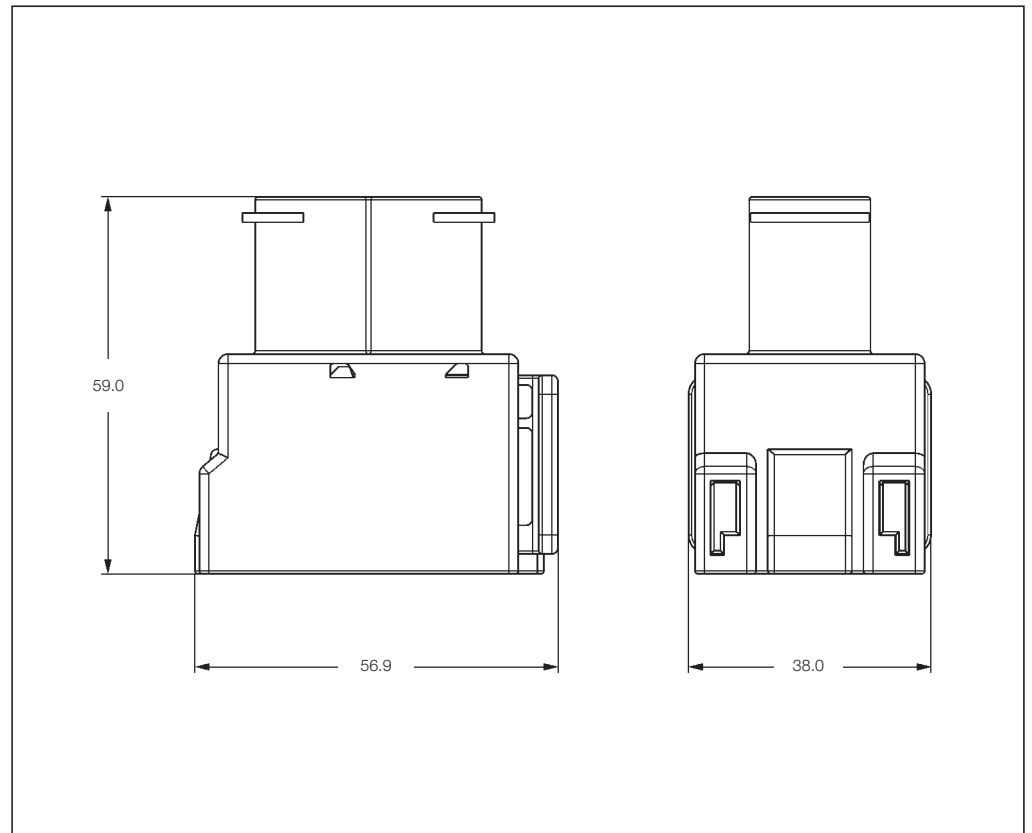

Sealed Receptacle Housings

No. of Positions	Keying Options	Housing Color	Part Numbers			
			Receptacle Housing	Package Quantity	Mating Tab Housing	Mating PCB Header
2	-	Black	1355328-1	250	1394026-2 1394026-1 (with Sealing for Wall Mounting)	-

Engineering Notes

A large grid area for engineering notes, consisting of a uniform grid of small squares covering the majority of the page.

Sealed 1.5 mm/2.8 mm Tab Housings

Technical Features

No. of Positions:
12 Positions

Housing Material:
PA66 GF

Wire Size Range:
4x 2.5 mm² FLR Max.
8x 1.0 mm² FLR Max.

Extraction Tools:
Part No. **539960-1**
Part No. **1-1579007-6**
dependent on the contact

Product Specification:
108-20242

Application Specification:
411-20073

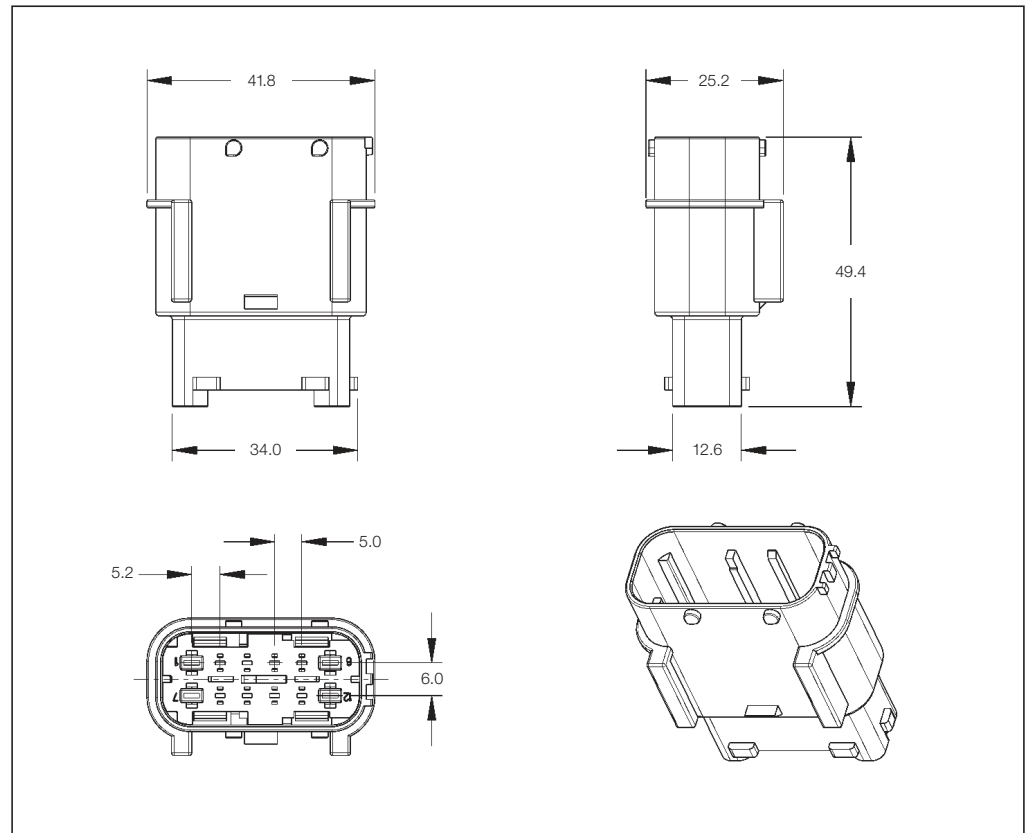

Sealed Tab Housings

No. of Positions	Keying Options	Housing Color	Part Numbers			
			Tab Housing	Package Quantity	Mating Receptacle Housing	Mating PCB Header
12	A Panel Hook on Left Side	Black	284844-1	500	284848-1	-
	A Panel Hook on Right Side	Black	284844-3	500	284848-3	-
	B Panel Hook on Left Side	Gray	284844-2	500	284848-2	-
	B Panel Hook on Right Side	Gray	284844-4	500	284848-4	-

Sealed 1.5 mm/2.8 mm Tab Housings

Technical Features

No. of Positions:
12 Positions

Housing Material:
PA66 GF

Wire Size Range:
4x 2.5 mm² FLR Max.
8x 1.5 mm² FLR Max.

Extraction Tools:
Part No. **539960-1**
Part No. **1-1579007-6**
dependent on the contact

Product Specification:
108-20264

Application Specification:
—

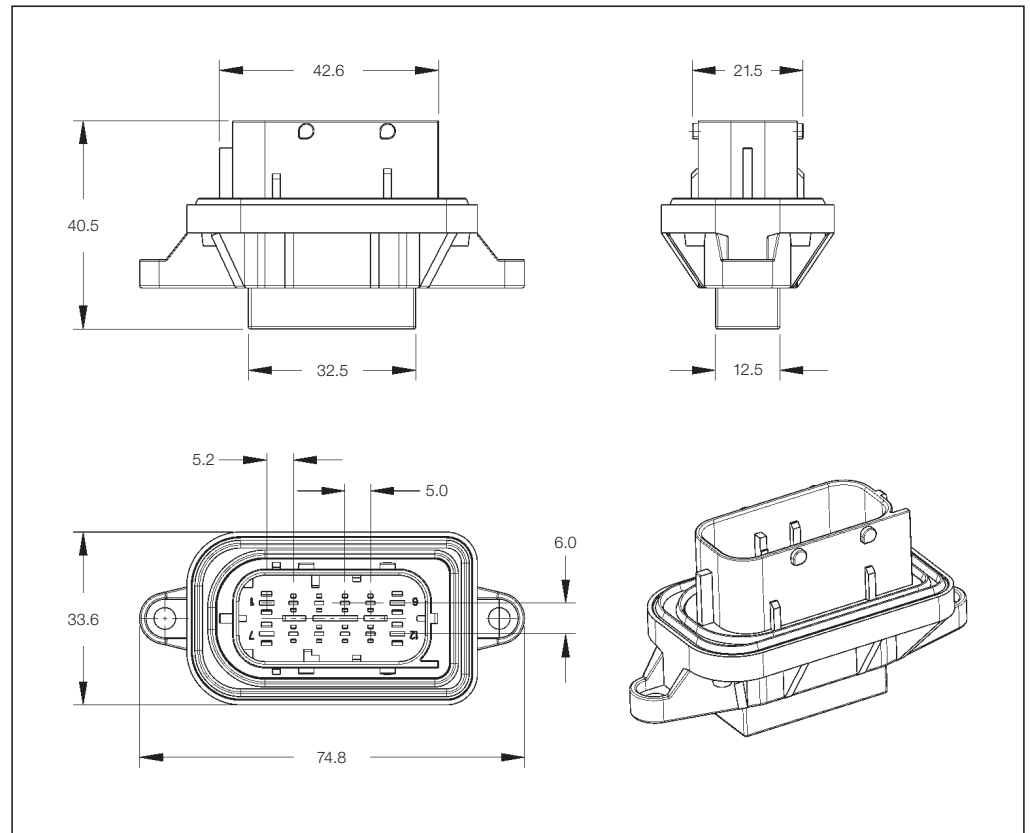

Sealed Tab Housings

No. of Positions	Keying Options	Housing Color	Part Numbers			
			Tab Housing with Flange	Package Quantity	Mating Receptacle Housing	Mating PCB Header
12	A	Black	1745045-1	350	284848-1	—

Sealed 1.5 mm/2.8 mm Tab Housings

Technical Features

No. of Positions:
20–24 Positions

Housing Material:
PA66 GF

Wire Size Range:
8x 2.5 mm² FLR Max.
16x 1.0 mm² FLR Max.

Extraction Tools:
Part No. **539960-1**
Part No. **1-1579007-6**
dependent on the contact

Product Specification:
108-20262

Application Specification:
411-20100

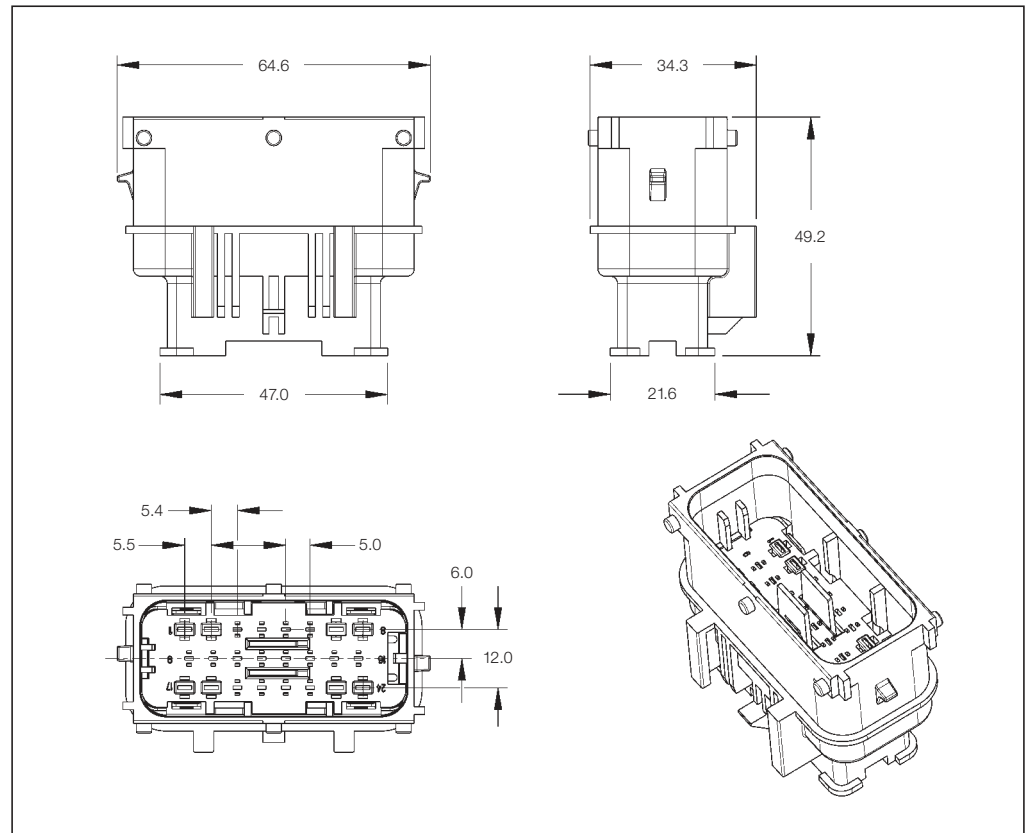

Sealed Mixed Tab Housings

No. of Positions	Keying Options	Housing Color	Part Numbers			
			Tab Housing with Flange	Package Quantity	Mating Receptacle Housing	Mating PCB Header
20	A	Black	1745044-1	225	1745043-1	–
					1745043-2	–
24	A	Gray	1745044-2	225	1745043-3	–
					1745043-4	–

Sealed 2.8 mm Tab Housings

Technical Features

No. of Positions:

2 Positions

Housing Material:

PA66 GF13

Wire Size Range:

2.5 mm² FLR Max.

Product Specification:

108-18180 (Tab Housing)

Application Specification:

114-18131 (Tab Housing)

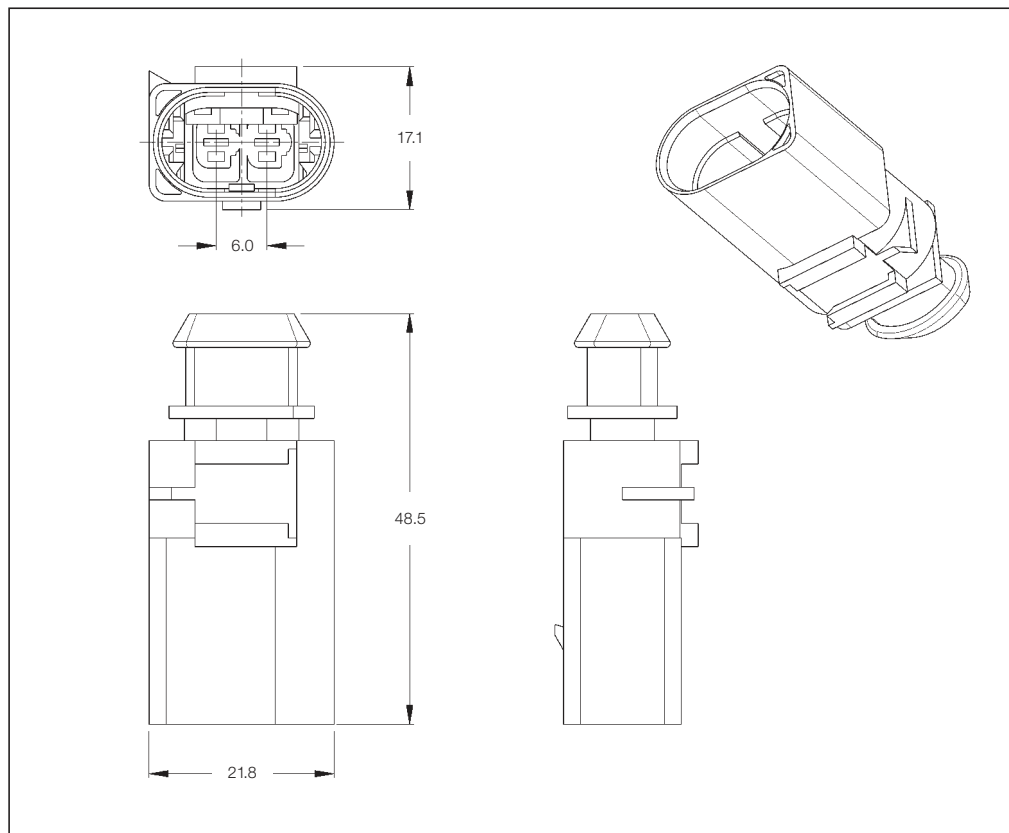

Sealed Tab Housings

No. of Positions	Keying Options	Housing Color	Part Numbers			
			Tab Housing	Package Quantity	Mating Receptacle Housing	Mating PCB Header
2	A	Black	1-966867-1	1,700	1-1355200-1	-
	B	Dark Brown	1-966867-2	1,700	2-1355200-1	-

Sealed 9.5 mm Tab Housings

Technical Features

No. of Positions:
1 Position

Housing Material:
PA66 GF15

Wire Size Range:
10.0 mm² FLK Max.

Extraction Tool:
Part No. **1-1579007-7**

Product Specification:
—

Application Specification:
—

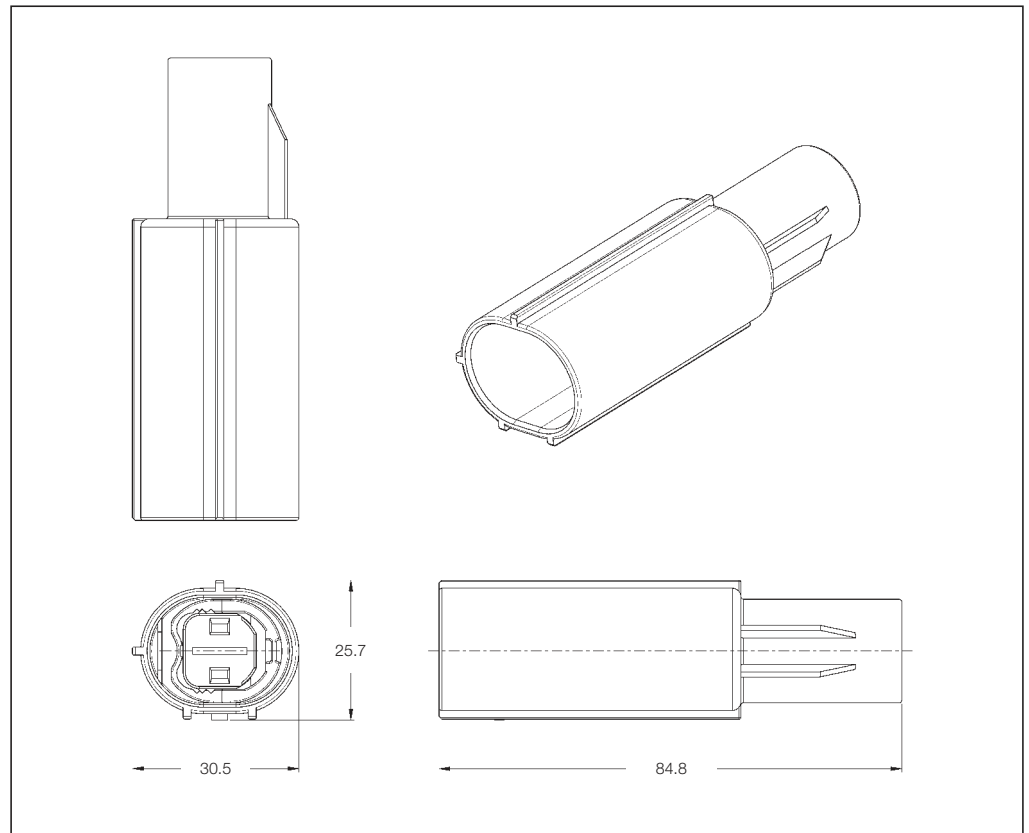

Sealed 9.5 mm Tab Housings

No. of Positions	Keying Options	Housing Color	Part Numbers			
			Tab Housing	Package Quantity	Mating Receptacle Housing	Mating PCB Header
1	—	Black	1743797-1	280	1743793-1	—

Sealed 9.5 mm Tab Housings

Technical Features

No. of Positions:
2 Positions

Housing Material:
PBT-GF13

Wire Size Range:
10.0 mm² FLK Max.

Extraction Tool:
Part No. **1-1579007-7**

Product Specification:
108-18809

Application Specification:
114-18501

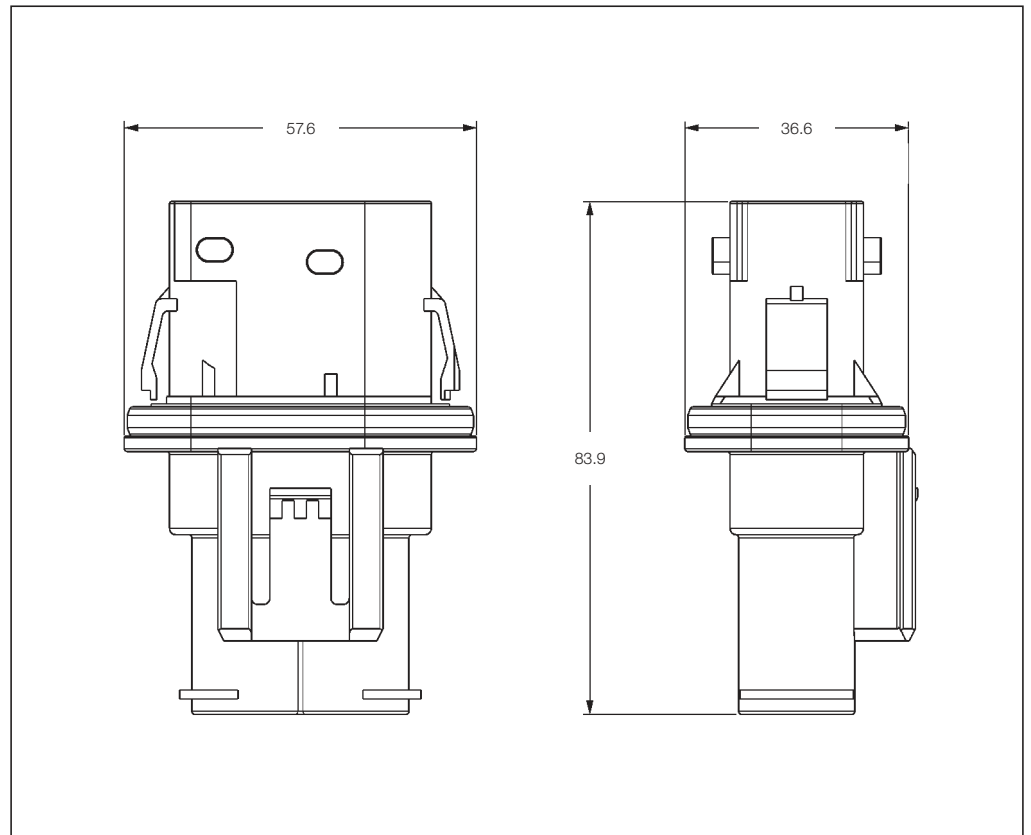

Sealed 9.5 mm Tab Housings

No. of Positions	Keying Options	Housing Color	Part Numbers			
			Tab Housing	Package Quantity	Mating Receptacle Housing	Mating PCB Header
2	-	Black	1394026-2	200	1355328-1	-
			1394026-1 (with Sealing for Wall Mounting)	200		

Introduction



**Heavy Duty Sealed
2.8 Lamp Connector**



The Heavy Duty Sealed 2.8 Lamp Connector is designed to meet the SAE J2577 standard for truck and truck trailer lighting in the commercial vehicle industry.

Primarily a sealed wire-to-device connector system, the Heavy Duty Sealed Lamp Connector provides the ability for fully sealed wire-to-wire applications as well.

This connector series will feature the AMP MCP 2.8 mm receptacle and tab as a contact system.

Technical Features

Plug Assembly

- 2 and 3 position molded plug housing
- Interface seal
- Secondary lock for plug and cap
- Wire dress cover (optional)

Cap Assembly

- 2 and 3 position molded cap housing
- Secondary lock for plug and cap
- Wire dress cover (optional)

Applications

- Stop lamps
 - Back-up lamps
 - Tail lamps
 - Side-turn signal lamps
 - Turn signal/hazard warning lamps
 - Work lamps
 - Side marker lamps
 - License lamps
 - Clearance lamps
 - Chassis component status (ABS)
 - Identification lamps
- Excludes forward lighting devices

Sealed Receptacle Housings

Technical Features

No. of Positions:

2 Positions

Housing Material:

Glass-Reinforced PBT

Wire Size Range:

2.0 mm² FLR Max.
14 AWG TXL Max.

Product Specification:

108-2430

Instruction Sheet:

408-10393

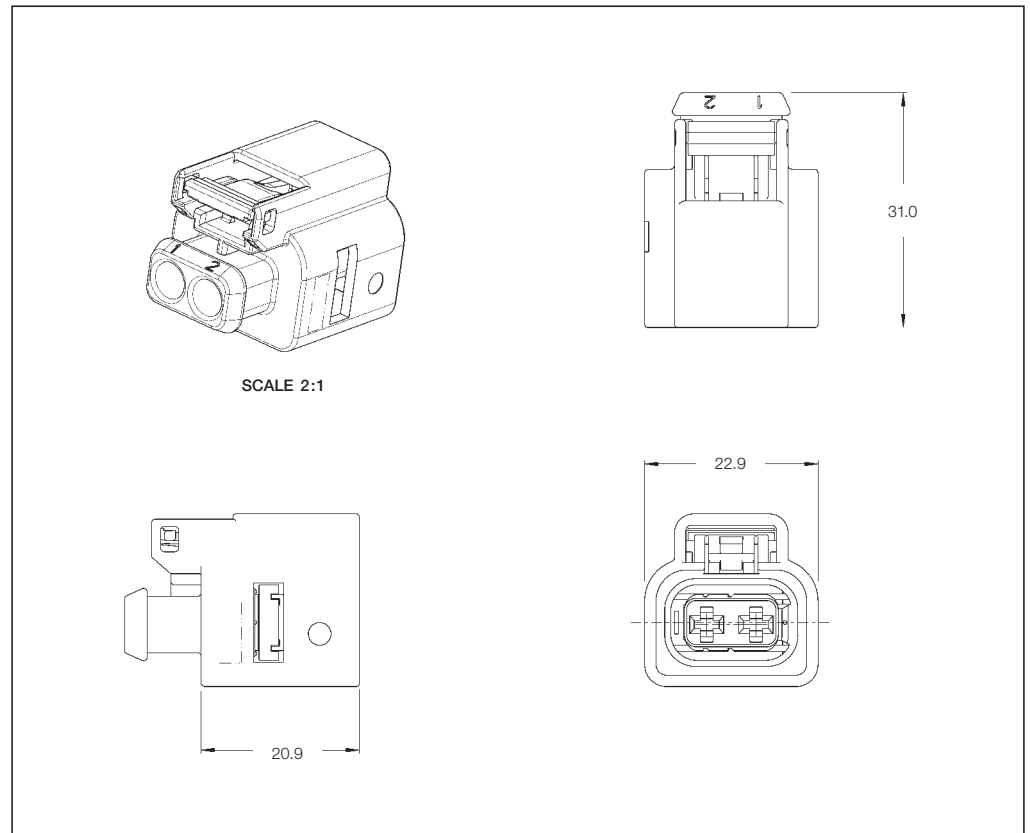

Sealed Receptacle Housings

No. of Positions	Keying Options	Housing Color	Part Numbers				
			Receptacle Housing	Package Quantity	Cover	Mating Tab Housing	Mating PCB Header
2	-	Black	1326455-1	-	-	1326743-1	-

Sealed Receptacle Housings

Technical Features

No. of Positions:
3 Positions

Housing Material:
Glass-Reinforced PBT

Wire Size Range:
2.0 mm² FLR Max.
14 AWG TXL Max.

Product Specification:
108-2430

Instruction Sheet:
408-10393

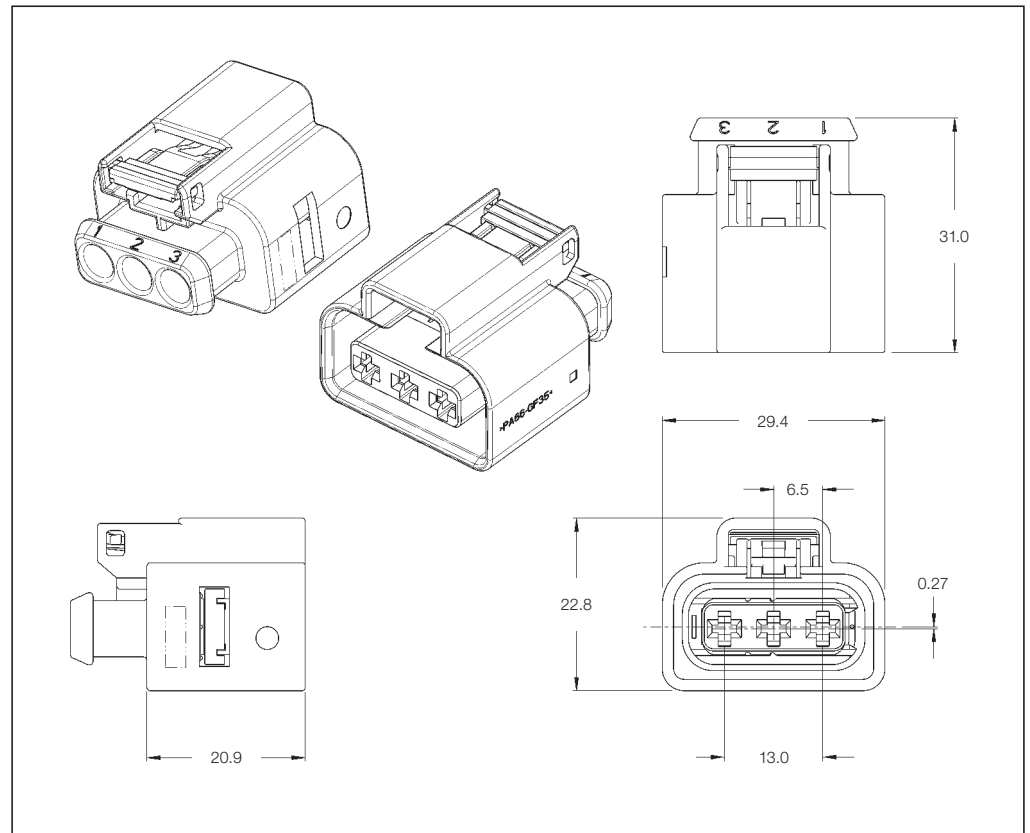

Sealed Receptacle Housings

No. of Positions	Keying Options	Housing Color	Part Numbers				
			Receptacle Housing	Package Quantity	Cover	Mating Tab Housing	Mating PCB Header
3	-	Black	1326460-1	600	-	1326744-1	-

Sealed Tab Housings

Technical Features

No. of Positions:
2 Positions

Housing Material:
Glass-Reinforced PBT

Wire Size Range:
2.0 mm² FLR Max.
14 AWG TXL Max.

Product Specification:
108-2430

Instruction Sheet:
408-10393

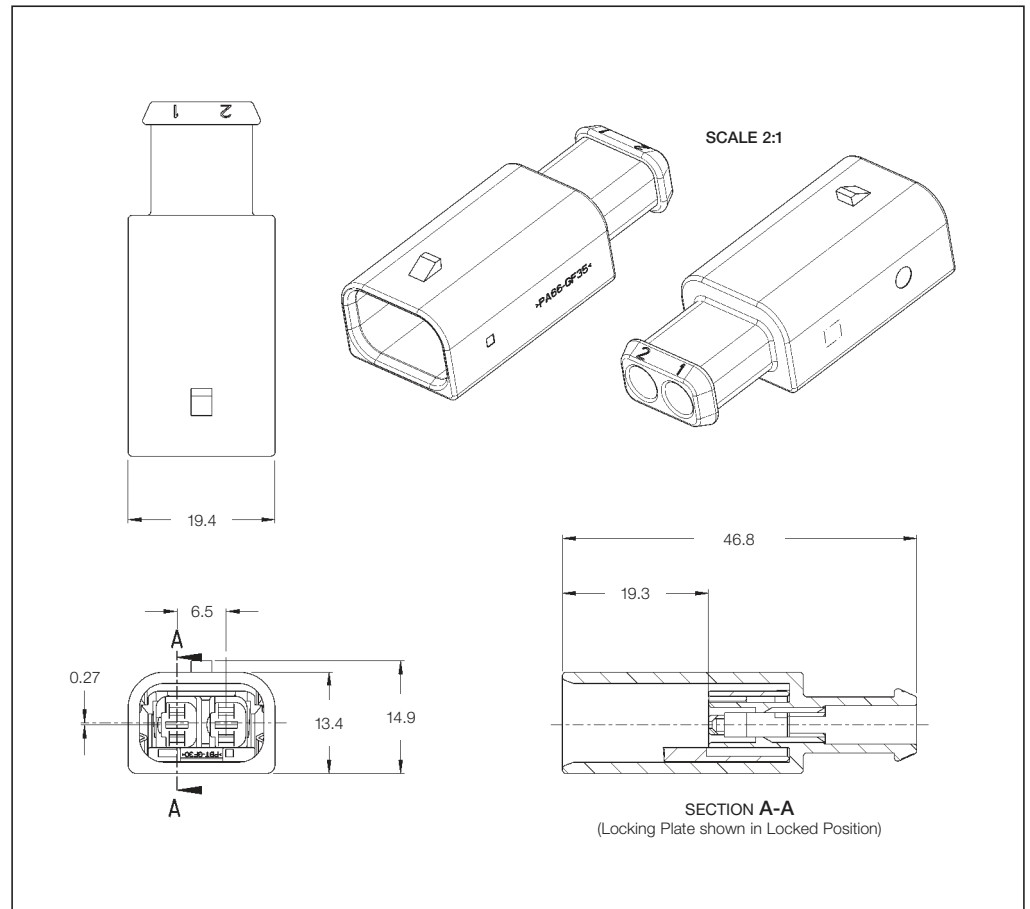

Sealed Tab Housings

No. of Positions	Keying Options	Housing Color	Part Numbers			
			Tab Housing	Package Quantity	Mating Receptacle Housing	Mating PCB Header
2	-	Black	1326743-1	-	1326455-1	-

Sealed Tab Housings

Technical Features

No. of Positions:
3 Positions

Housing Material:
Glass-Reinforced PBT

Wire Size Range:
2.0 mm² FLR Max.
14 AWG TXL Max.

Product Specification:
108-2430

Instruction Sheet:
408-10393

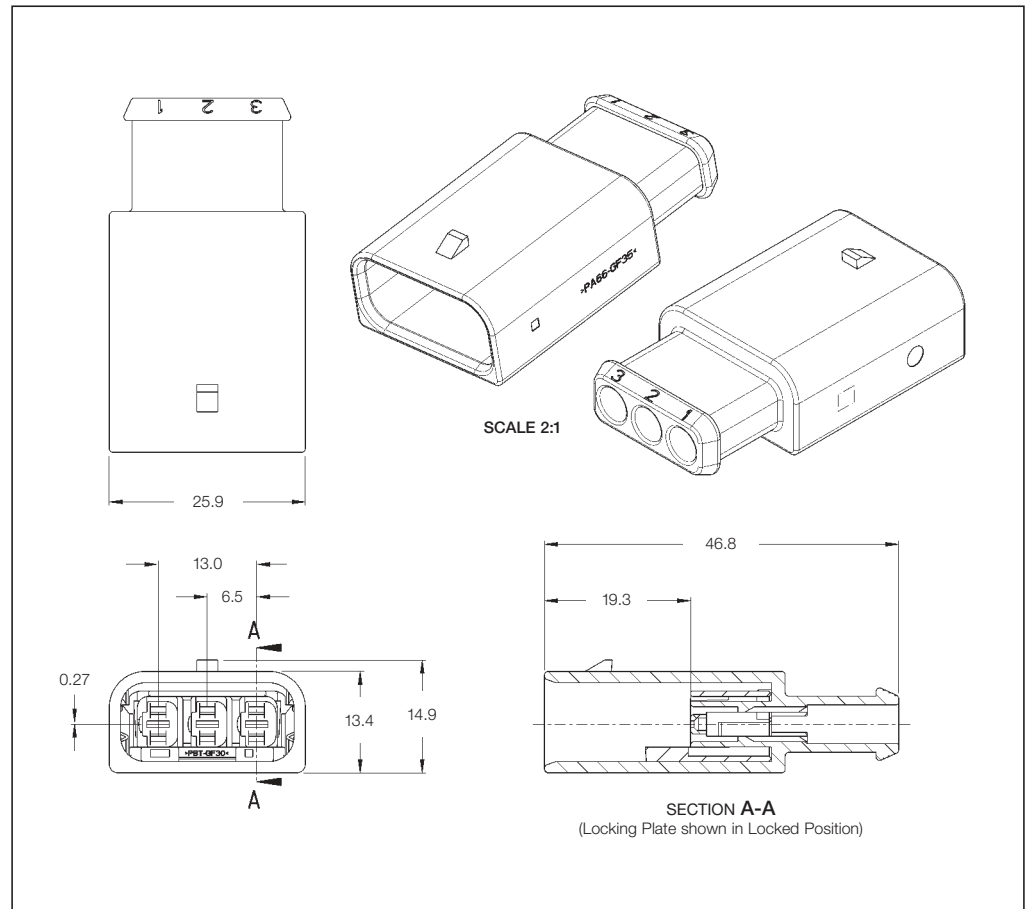

Sealed Tab Housings

No. of Positions	Keying Options	Housing Color	Part Numbers			
			Tab Housing	Package Quantity	Mating Receptacle Housing	Mating PCB Header
3	–	Black	1326744-1	–	1326460-1	–

Accessories

Technical Features

No. of Positions:
2 and 3 Positions

Wire Dress Cover Material:
Polyester Compound

Wire Size Range:
2.0 mm² FLR Max.
14 AWG TXL Max.

Product Specification:
108-2430

Instruction Sheet:
408-10393

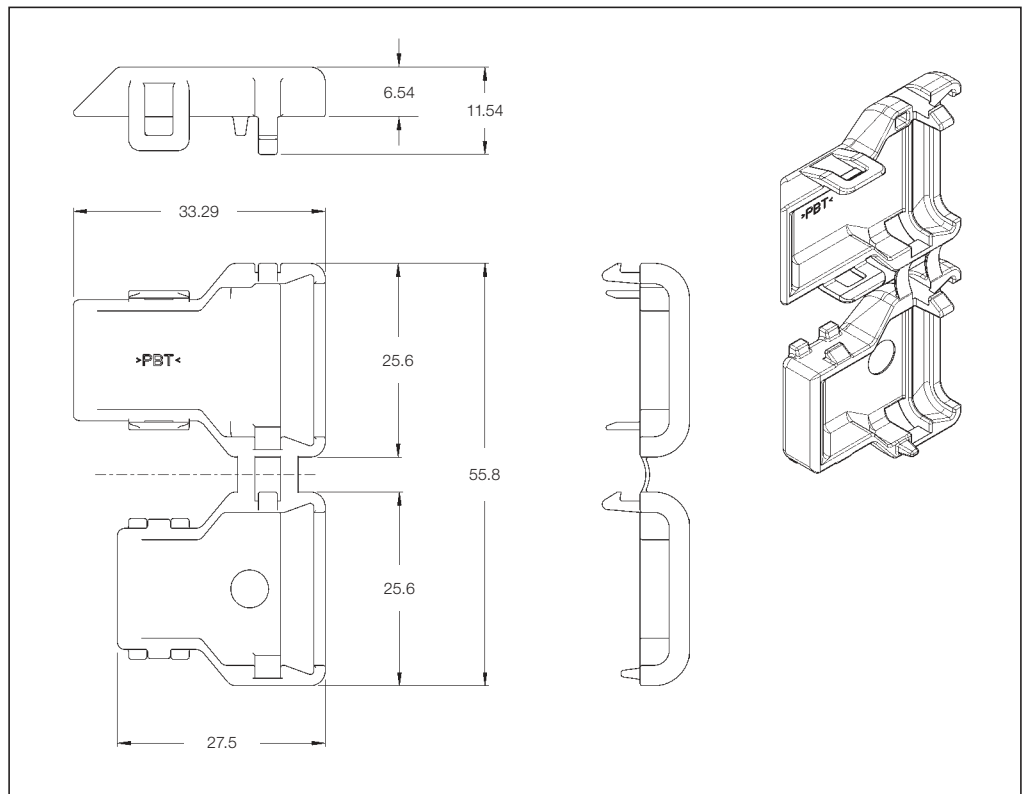
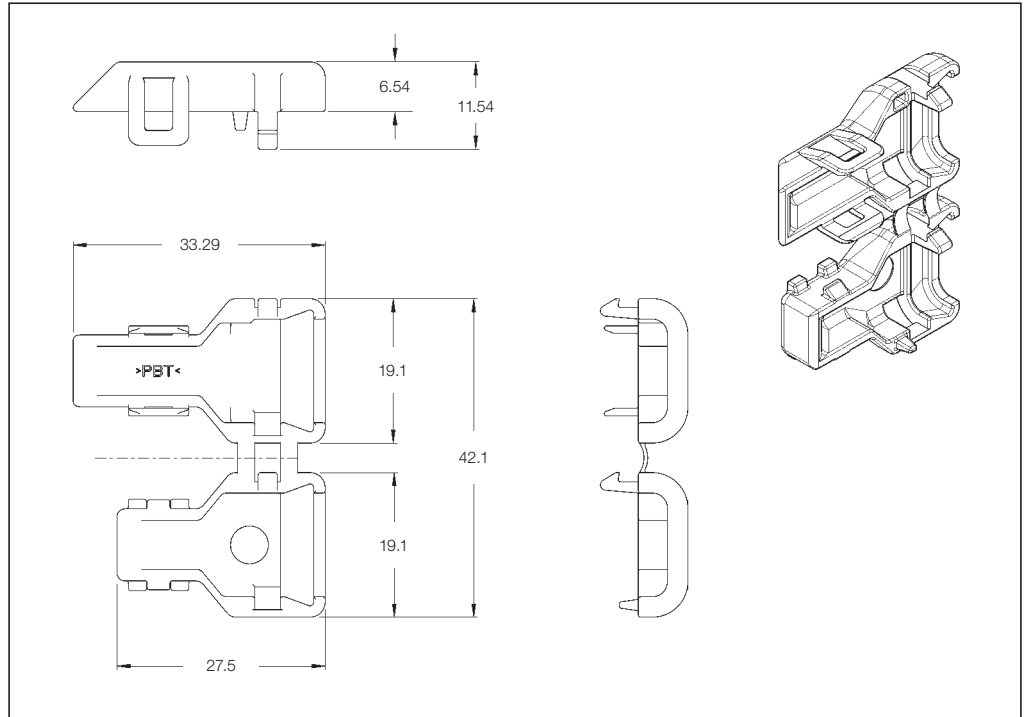

Description	Color	Part Number	Package Quantity
2 Position Wire Dress Cover	Black	1326459-1	-
3 Position Wire Dress Cover	Black	1326464-1	-

Introduction



Heavy Duty Sealed Connector Series (HDSCS) for the Automotive Industry



The Heavy Duty Sealed Connector Series, so called HDSCS, is targeted for the commercial vehicle industry and off-road applications.

This wire-to-wire and wire-to-device connector program was designed to meet the rigorous demands of an industry that requires the highest standards in performance.

The HDSCS program consists of five groups of connectors in different sizes, starting from 2 up to 18 way connectors. In addition, mixed combinations with signal and power lines are available.

This HDSCS program will feature the AMP MCP 1.5K, AMP MCP 2.8 and AMP MCP 6.3/4.8K receptacles and tabs as a contact system.

Technical Features

- High reliability status supported for long term use
- High vibration level supported
- Perfect design to avoid quality problems, reduce manufacturing and service cost
- Integrated secondary locking device delivered in pre-locked position
- Polarization, several keyings
- Clear handling, low mating force with a reliable slide locking mechanism delivered in pre-locked position

For complete Product Information, please order Catalog 1654282

Engineering Notes

A large grid area for engineering notes, consisting of a uniform grid of small squares, intended for technical drawing or calculations.

Introduction



Reliable Connector System for the Truck Industry



LEAVYSEAL connectors have been especially developed to meet tough requirements of the truck industry. This fully sealed series combines the advantages of proven AMP MCP terminals with a robust design and easy mating of multiposition connectors.

It gives a choice of 7 groups, 15 to 120 positions with terminals of 3 different sizes.

The lever-slide mechanism reduces the force required to close the system. Due to high vibration resistance, perfect temperature behaviour and the size, LEAVYSEAL connectors are the product of choice for major commercial vehicles ECU manufacturers.

Typical Applications are:
Device interface, door, pass-through (bulkhead) or harness disconnection.

Technical Features

- High vibration level supported
- Integrated secondary locking device delivered in pre-locked position
- Polarization, several keyings
- Lever-slide mechanism
- Easy handling
- Mixed terminal sizes in one housing

Sealed AMP MCP 2.8 Receptacle Housings

Technical Features

No. of Positions:

15 Positions

Housing Material:

PBT-GF20

Extraction Tool:

Part No. **1579007-1**

Wire Size Range:

2.5 mm² FLR Max.
AWG 12 TXL Max.

Product Specification:

108-18696

Application Specification:

114-18376

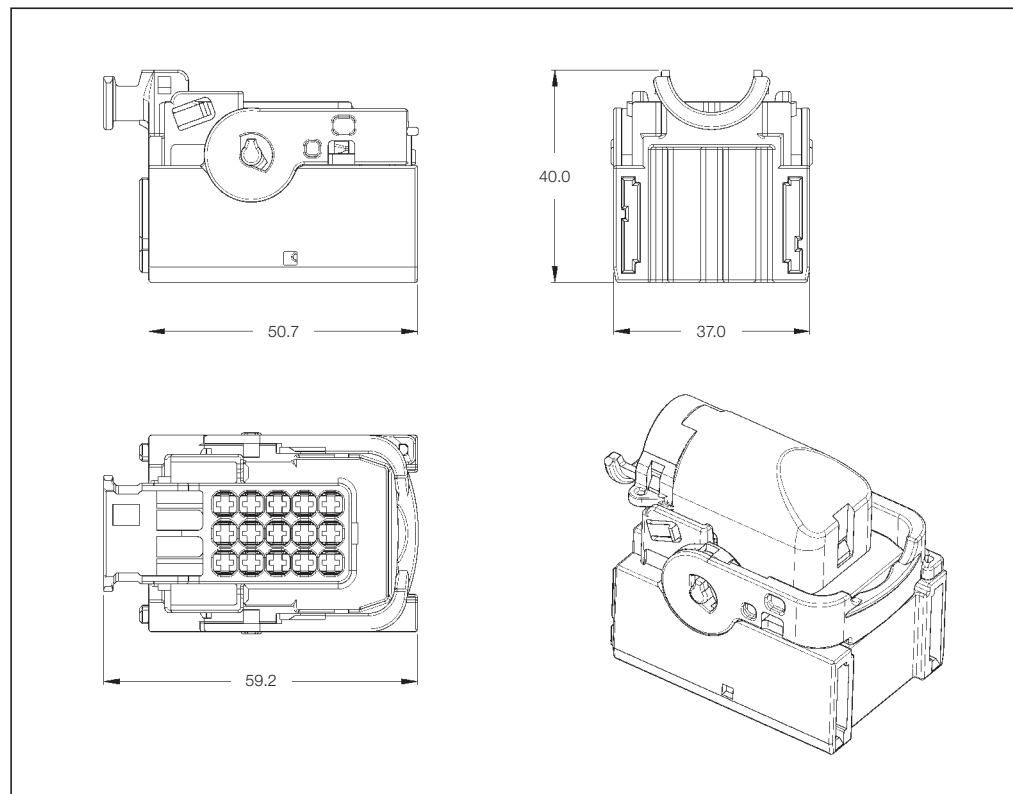

Sealed Receptacle Housings

No. of Positions	Keying Options	Housing Color	Part Numbers			
			Receptacle Housing	Package Quantity	Cover	Mating Tab Housing
15	A	Black	1-1534126-1	420		1703799-1
	B	Natural	2-1534126-1	420	9-1394049-1	*)
	C	Blue	3-1534126-1	420		*)

*) On request.

Sealed AMP MCP 1.5K/2.8 Receptacle Housings

Technical Features

No. of Positions:
22 Positions

Housing Material:
PBT-GF30

Wire Size Range:
16x AMP MCP 1.5K
1.5 mm² FLR Max.
6x AMP MCP 2.8
2.5 mm² FLR Max.
AWG 12 TXL Max.

Extraction Tools:
Part No. **1579007-1**
Part No. **1-1579007-1**
dependent on the contact

Product Specification:
108-94204

Application Specification:
114-18993

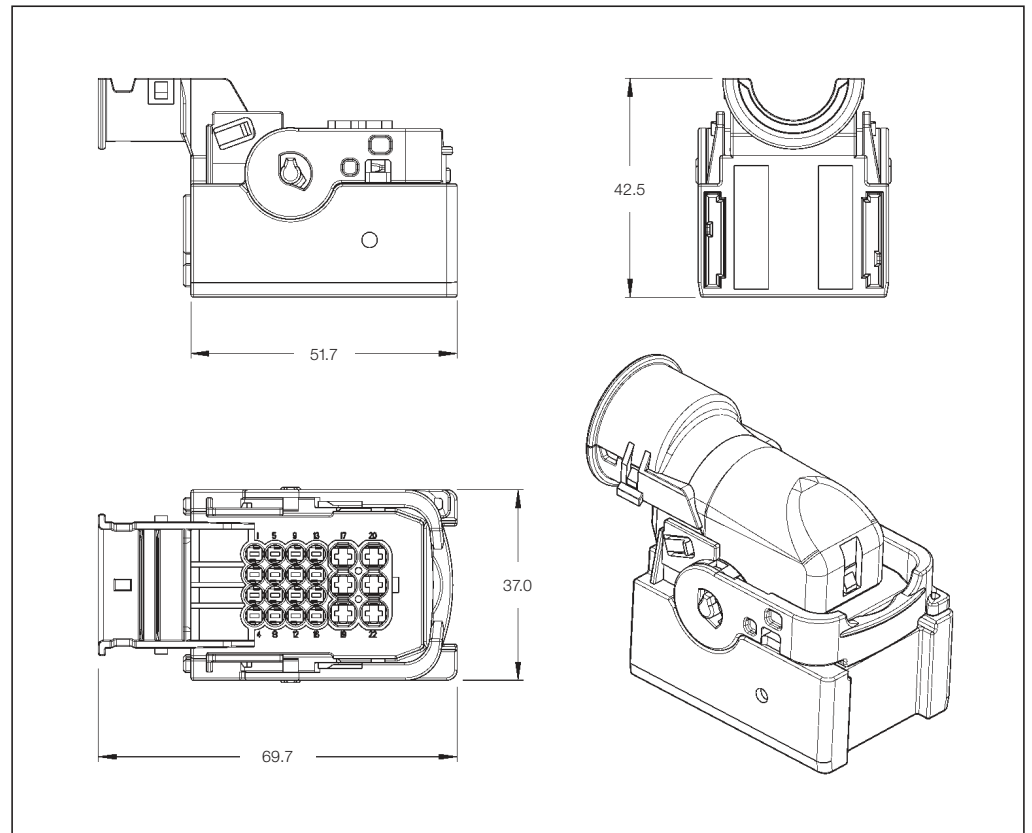

Sealed Mixed Receptacle Housings

No. of Positions	Keying Options	Housing Color	Part Numbers			
			Receptacle Housing	Package Quantity	Cover	Mating Tab Housing
22	A	Black	1-1823440-3	180	2112452-1	1-1823449-1
	B	Gray	2-1823440-3	180		*)
	C	Blue	3-1823440-3	180		*)
	D	Green	4-1823440-3	180		*)

*) On request.

Sealed AMP MCP 2.8 Receptacle Housings

Technical Features

No. of Positions:
21 Positions

Housing Material:
PBT-GF20

Wire Size Range:
2.5 mm² FLR Max.
AWG 12 TXL Max.

Extraction Tool:
Part No. **1579007-1**

Product Specification:
108-18696

Application Specification:
114-18376

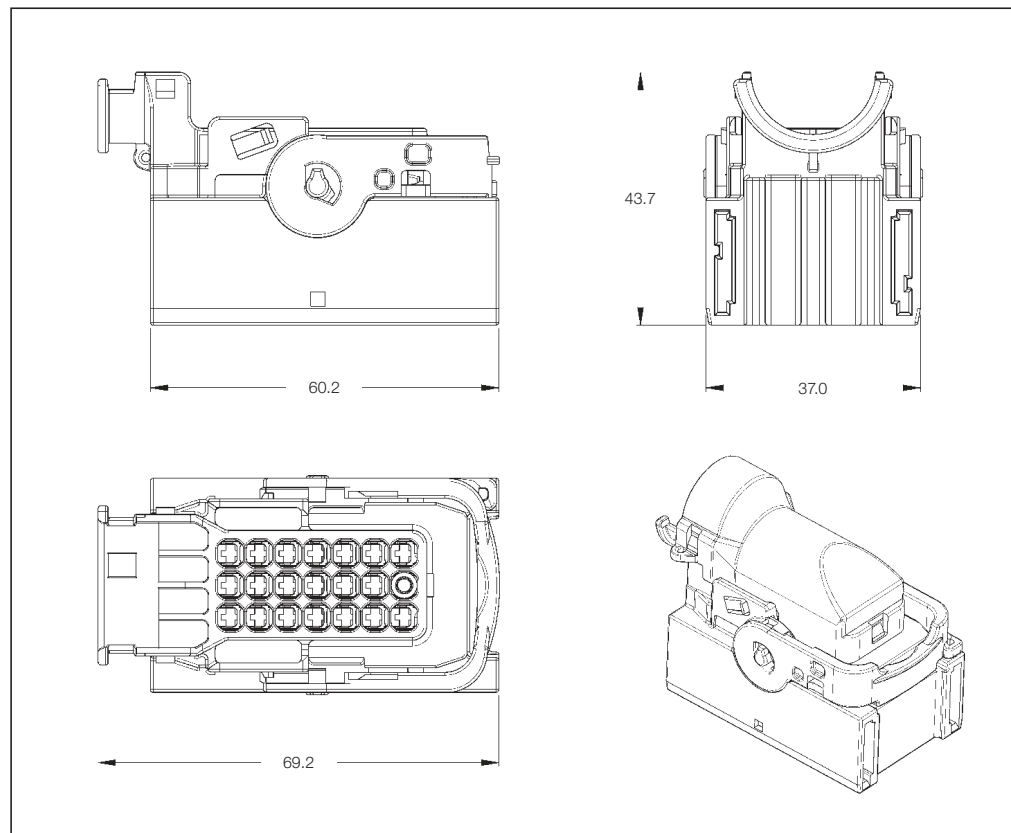

Sealed Receptacle Housings

No. of Positions	Keying Options	Housing Color	Part Numbers				
			Receptacle Housing	Package Quantity	Cover	Mating Tab Housing with Flange	Mating Vertical PCB Header
21	A	Black	1-1534127-1	160	9-1394050-1	1-2112162-1	1534238-1
	B	Natural	2-1534127-1	160		*)	*)
	C	Blue	3-1534127-1	160		*)	*)
	D	Violet	4-1534127-1	160		*)	*)

*) On request.

Sealed AMP MCP 1.5K/2.8/6.3 Receptacle Housings

Technical Features

No. of Positions:
29 Positions

Housing Material:
PBT-GF30

Wire Size Range:
26x AMP MCP 1.5K
1.5 mm² FLR Max.
2x AMP MCP 2.8
2.5 mm² FLR Max.
1x AMP MCP 4.8K/6.3
6.0 mm² FLR Max.

Extraction Tools:
Part No. **1579007-1**
Part No. **1-1579007-1**
Part No. **1-1579007-3**
dependent on the contact

Product Specification:
108-94215

Application Specification:
114-94011

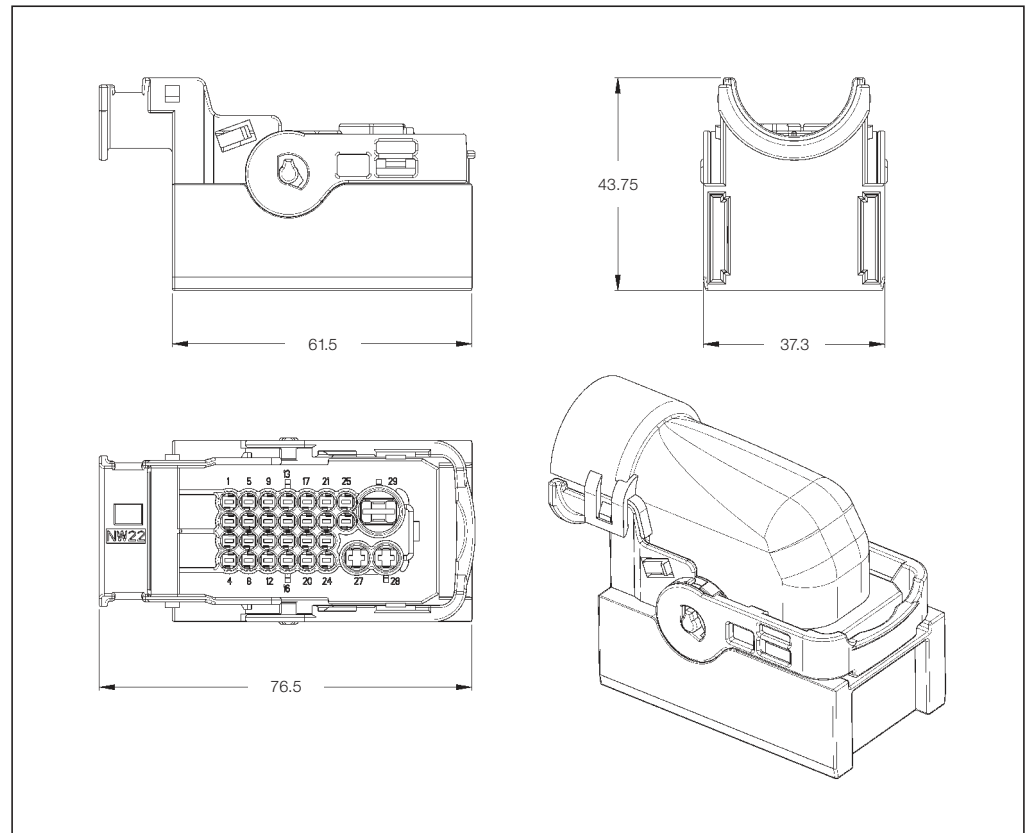

Sealed Mixed Receptacle Housings

No. of Positions	Keying Options	Housing Color	Part Numbers			
			Receptacle Housing	Package Quantity	Cover	Mating Tab Housing
29	A	Black	1-1823402-1	117		
	B	Gray	2-1823402-1	117	*)	*)
	C	Blue	3-1823402-1	117		
	D	Green	*)	-		

*) On request.

Sealed AMP MCP 1.5K/2.8/6.3 Receptacle Housings

Technical Features

No. of Positions:
26 Positions

Housing Material:
PBT-GF30

Wire Size Range:
12x AMP MCP 1.5K
1.5 mm² FLR Max.
12x AMP MCP 2.8
2.5 mm² FLR Max.
2x AMP MCP 4.8K/6.3
6.0 mm² FLR Max.

Extraction Tools:
Part No. **1579007-1**
Part No. **1-1579007-1**
Part No. **1-1579007-3**
dependent on the contact

Product Specification:
108-94214

Application Specification:
114-94010

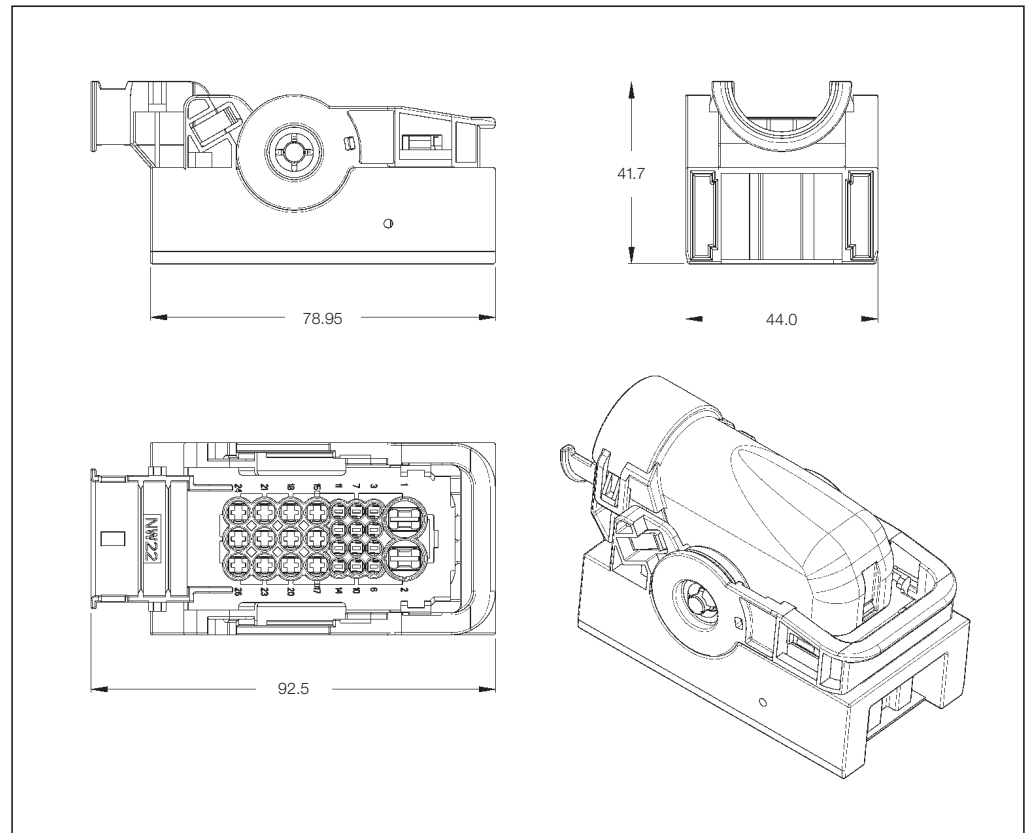

Sealed Mixed Receptacle Housings

No. of Positions	Keying Options	Housing Color	Part Numbers			
			Receptacle Housing	Package Quantity	Cover	Mating Tab Housing
26	A	Black	1-2112035-1	96	2112046-1	1-2112041-1 1-2112041-2

Sealed AMP MCP 1.5K Receptacle Housings

Technical Features

No. of Positions:
46 Positions

Housing Material:
PBT-GF20

Extraction Tool:
Part No. **1-1579007-1**

Wire Size Range:
1.5 mm² FLR Max.
AWG 16 TXL Max.

Product Specification:
108-94216

Application Specification:
114-94012

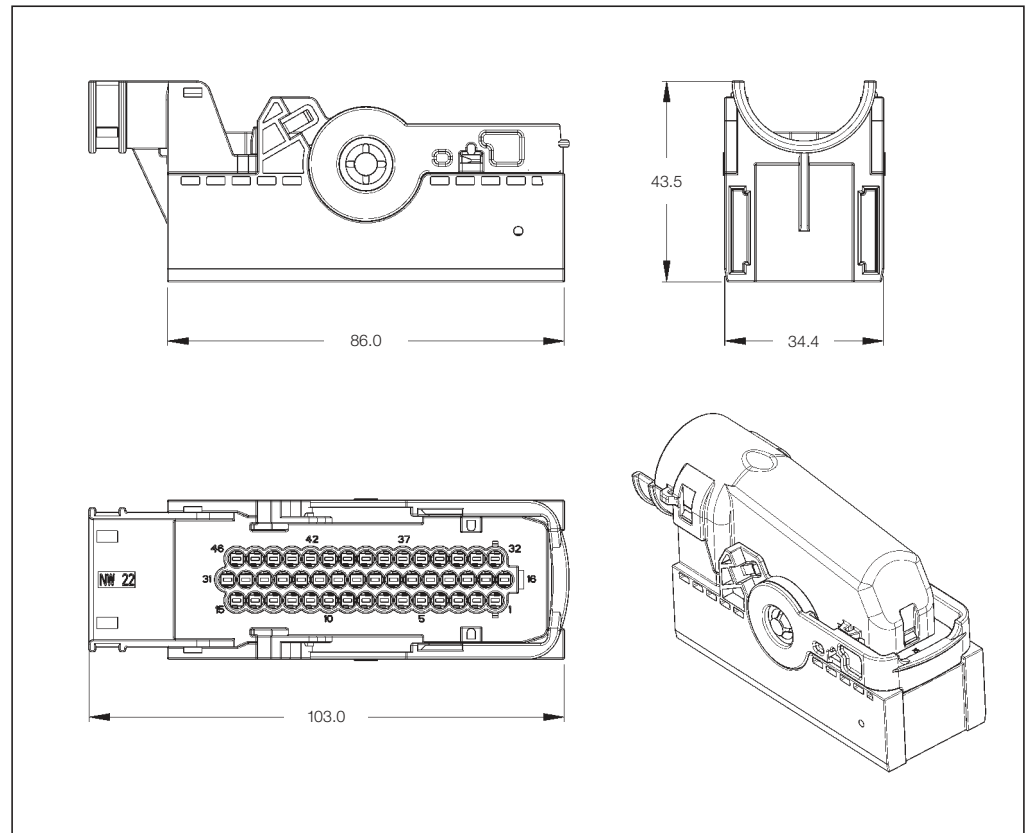

Sealed Receptacle Housings

No. of Positions	Keying Options	Housing Color	Part Numbers			
			Receptacle Housing	Package Quantity	Cover	Mating Tab Header
46	A	Black	1-2112231-1	174	2112233-1	*)

*) On request.

Sealed AMP MCP 1.5K/2.8 Receptacle Housings

Technical Features

No. of Positions:

62 Positions

Housing Material:

PBT-GF20

Wire Size Range:

56x AMP MCP 1.5K

1.5 mm² FLR Max.

AWG 16 TXL Max.

6x AMP MCP 2.8

2.5 mm² FLR Max.

AWG 12 TXL Max.

Extraction Tools:

Part No. **1579007-1**

Part No. **1-1579007-1**

dependent on the contact

Product Specification:

108-18946

Application Specification:

114-18660

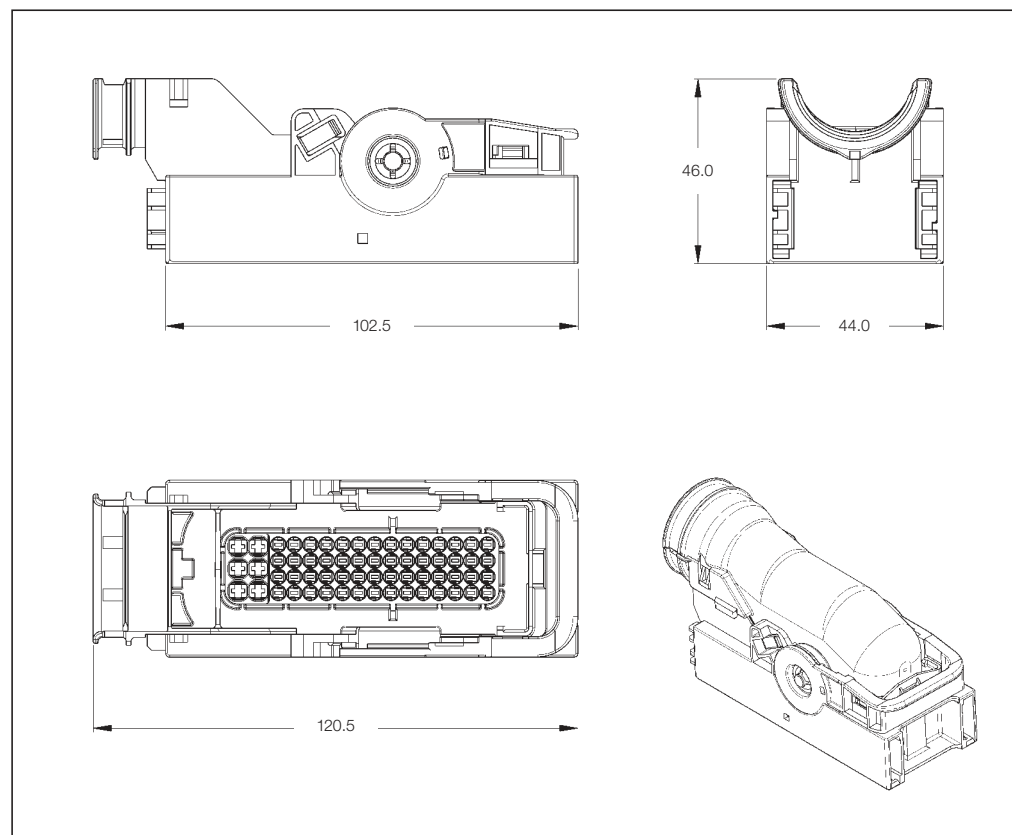

Sealed Mixed Receptacle Housings

No. of Positions	Keying Options	Housing Color	Part Numbers				
			Receptacle Housing	Cover	Mating Tab Housing	Mating PCB Header Straight	Mating PCB Header 90° Angled
62	A	Black	1-1418883-1	1418882-1	1-1718324-1	1-1418362-1	1-1418362-3
	B	Gray	2-1418883-1		2-1718324-1	2-1418362-1	2-1418362-3
	C	Blue	3-1418883-1		3-1718324-1	-	-
	D	Green	4-1418883-1		-	-	-
62*	A	Black	1-1823498-1	1823500-1	-	-	-
	B	Gray	2-1823498-1		-	-	-
	C	Blue	3-1823498-1		-	-	-
	D	Green	4-1823498-1		-	-	-

*) UL 94 V-0 rated.

Sealed AMP MCP 2.8 Receptacle Housings

Technical Features

No. of Positions:
39 Positions

Housing Material:
PBT-GF20

Wire Size Range:
AMP MCP 2.8
2.5 mm² FLR Max.
AWG 12 TXL Max.

Extraction Tool:
Part No. **1579007-1**

Product Specification:
108-18946

Application Specification:
114-18660

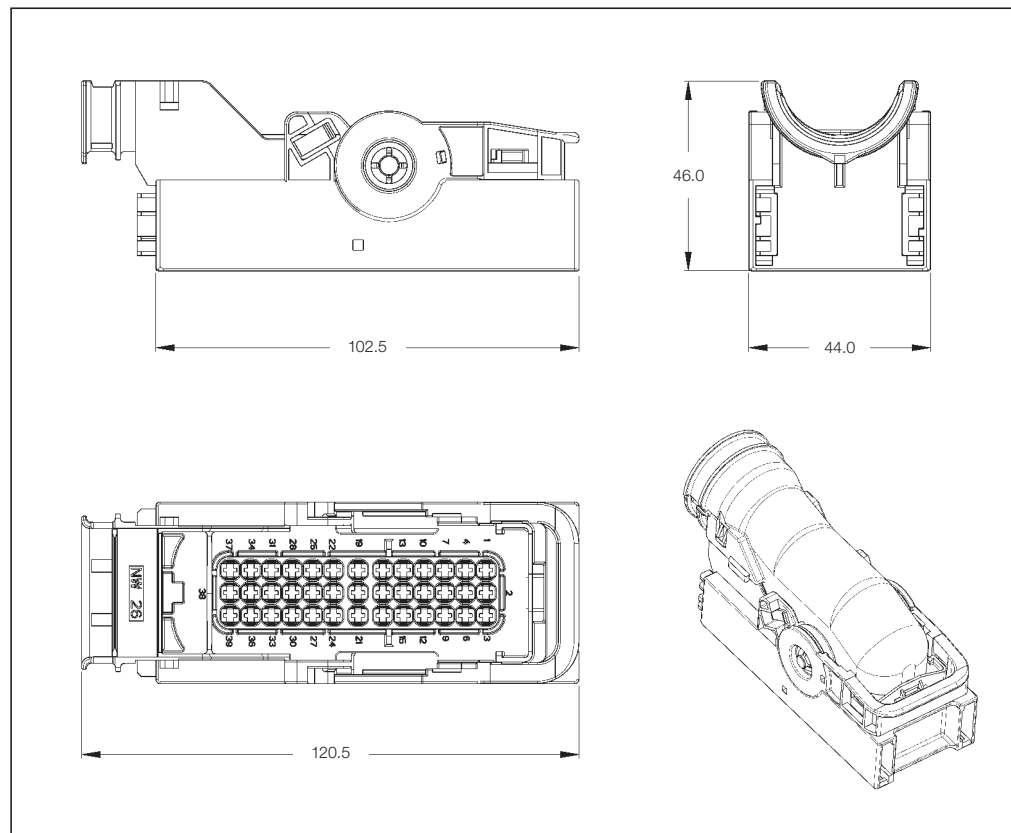

Sealed Receptacle Housings

No. of Positions	Keying Options	Housing Color	Part Numbers				
			Receptacle Housing	Cover	Mating Tab Housing	Mating PCB Header Straight	Mating PCB Header 90° Angled
39	E	Emerald Green	5-1718321-3	1418882-1	5-1718323-1	5-1418363-1	5-1418363-3
	F	Fawn Brown	6-1718321-3	1418882-1	6-1718323-1	—	—

Sealed AMP MCP 2.8/6.3 Receptacle Housings

Technical Features

No. of Positions:
31 Positions

Housing Material:
PBT-GF20

Wire Size Range:
27x AMP MCP 2.8
2.5 mm² FLR Max./
AWG 12 TXL Max.
4x AMP MCP 4.8K/6.3
6.0 mm² FLR Max.

Extraction Tools:
Part No. **1579007-1**
Part No. **1-1579007-3**
dependent on the contact

Product Specification:
108-18946

Application Specification:
114-18660

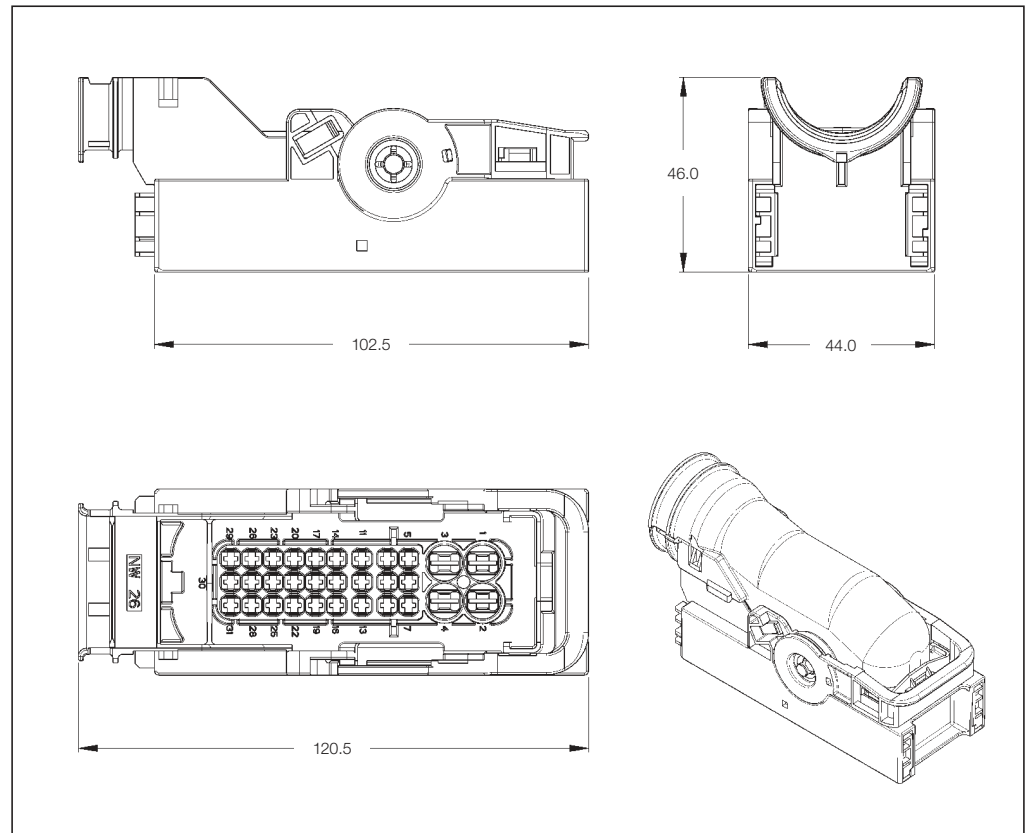

Sealed Receptacle Housings

No. of Positions	Keying Options	Housing Color	Part Numbers				
			Receptacle Housing	Cover	Mating Tab Housing	Mating PCB Header Straight	Mating PCB Header 90° Angled
31	A	Bordeaux	1-1564297-6	1418882-1	*)	*)	*)

*) On request.

Sealed AMP MCP 1.5K Receptacle Housings

Technical Features

No. of Positions:

92 Positions

Housing Material:

PBT-GF20

Extraction Tool:

Part No. **1-1579007-1**

Wire Size Range:

1.5 mm² FLR Max.

AWG 16 TXL Max.

Product Specification:

108-18893

Application Specification:

114-18598

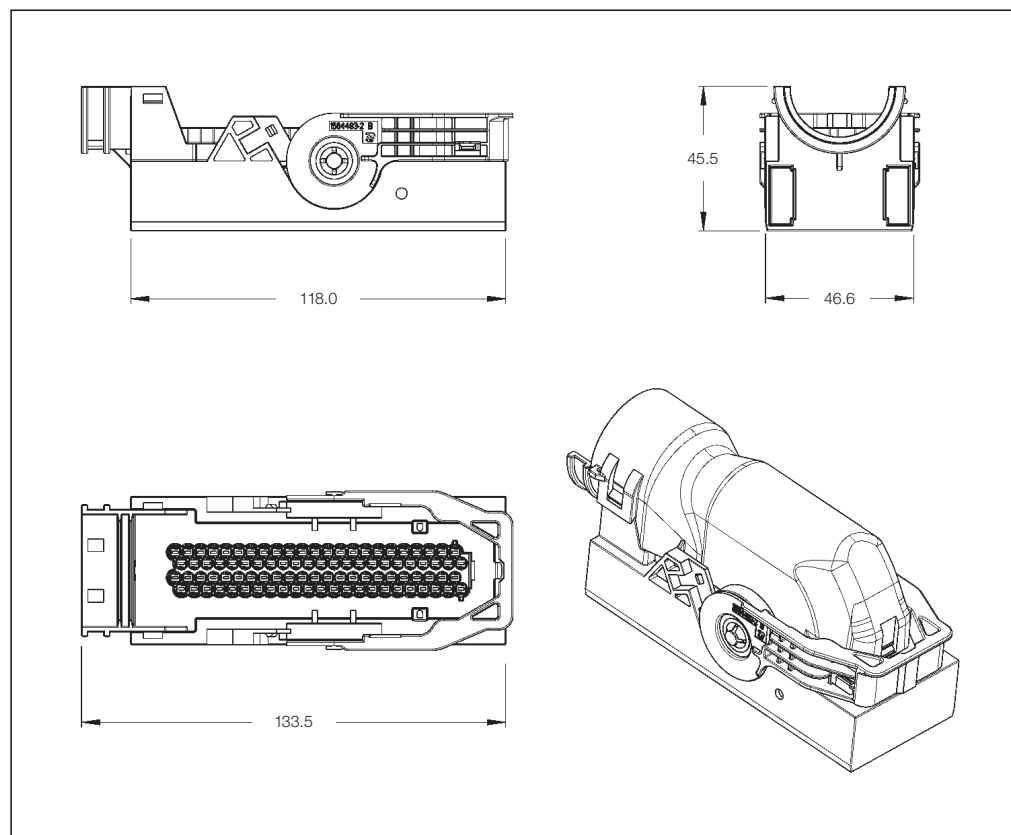

Sealed Receptacle Housings

No. of Positions	Keying Options	Housing Color	Part Numbers			
			Receptacle Housing	Package Quantity	Cover	Mating Tab Header
92	A	Black	1703998-1*	64	1703997-1	1-1452228-9
	A	Black	3-1703998-1**	64	2141345-1	1-1452228-9
	B	Black	4-1703998-1**	64	2141345-1	-
	C	Black	5-1703998-1**	64	2141345-1	-

*) NW 26 wire exit

**) NW 29 wire exit

Engineering Notes

A large grid area for engineering notes, consisting of a uniform grid of small squares covering the majority of the page.

Sealed 2.8 mm Tab Housings

Technical Features

No. of Positions:

15 Positions

Housing Material:

PBT-GF20

Wire Size Range:

2.5 mm² FLR Max.
AWG 12 TXL Max.

Extraction Tool:

Part No. **1-1579007-6**

Product Specification:

108-18696

Application Specification:

114-18376

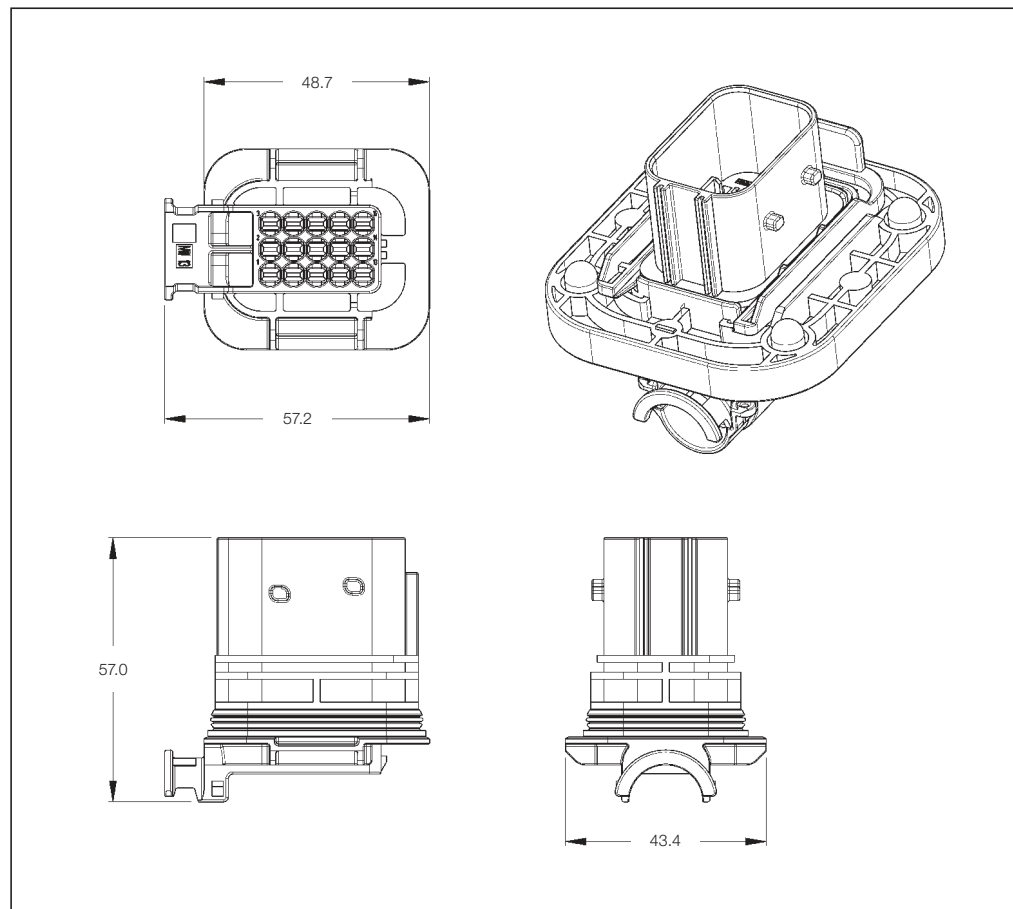

Sealed 2.8 mm Tab Housings

No. of Positions	Keying Options	Housing Color	Part Numbers				
			Tab Housing	Cover	Adapter	Locking Slide	Mating Receptacle Housing
15	A	Black	1703799-1				1-1534126-1
	B	Natural	*)	9-1394049-1	1703806-1	1703804-1	2-1534126-1
	C	Blue	*)				3-1534126-1

*) On request.

Sealed 1.5 mm/2.8 mm Tab Housings

Technical Features

No. of Positions:

22 Positions

Housing Material:

PBT-GF30

Wire Size Range:

1.5 mm² FLR Max.
2.5 mm² FLR Max.
AWG 12 TXL Max.

Extraction Tools:

Part No. **1-1579007-1**
Part No. **1-1579007-6**
dependent on the contact

Product Specification:

108-94204

Application Specification:

114-18993

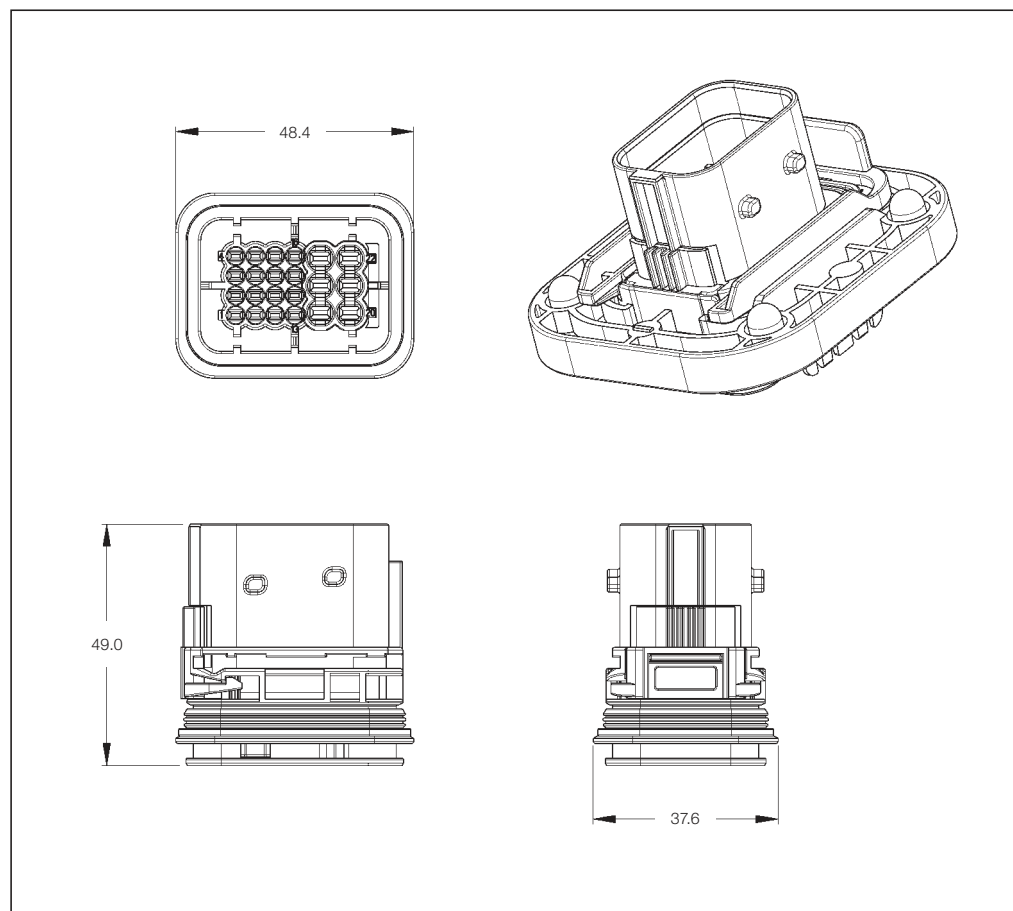

Sealed Mixed Tab Housings

No. of Positions	Keying Options	Housing Color	Part Numbers				
			Tab Housing	Cover	Adapter	Locking Slide	Mating Receptacle Housing
22	A	Black	1-1823449-1				1-1823440-3
	B	Gray	*)				2-1823440-3
	C	Blue	*)	*)	1703806-1	1703804-1	3-1823440-3
	D	Green	*)				4-1823440-3

*) On request.

Sealed 2.8 mm Tab Housings

Technical Features

No. of Positions:
21 Positions

Housing Material:
PBT-GF30

Wire Size Range:
2.5 mm² FLR Max.
AWG 12 TXL Max.

Extraction Tool:
Part No. **1-1579007-6**

Product Specification:
108-18696

Application Specification:
114-18376

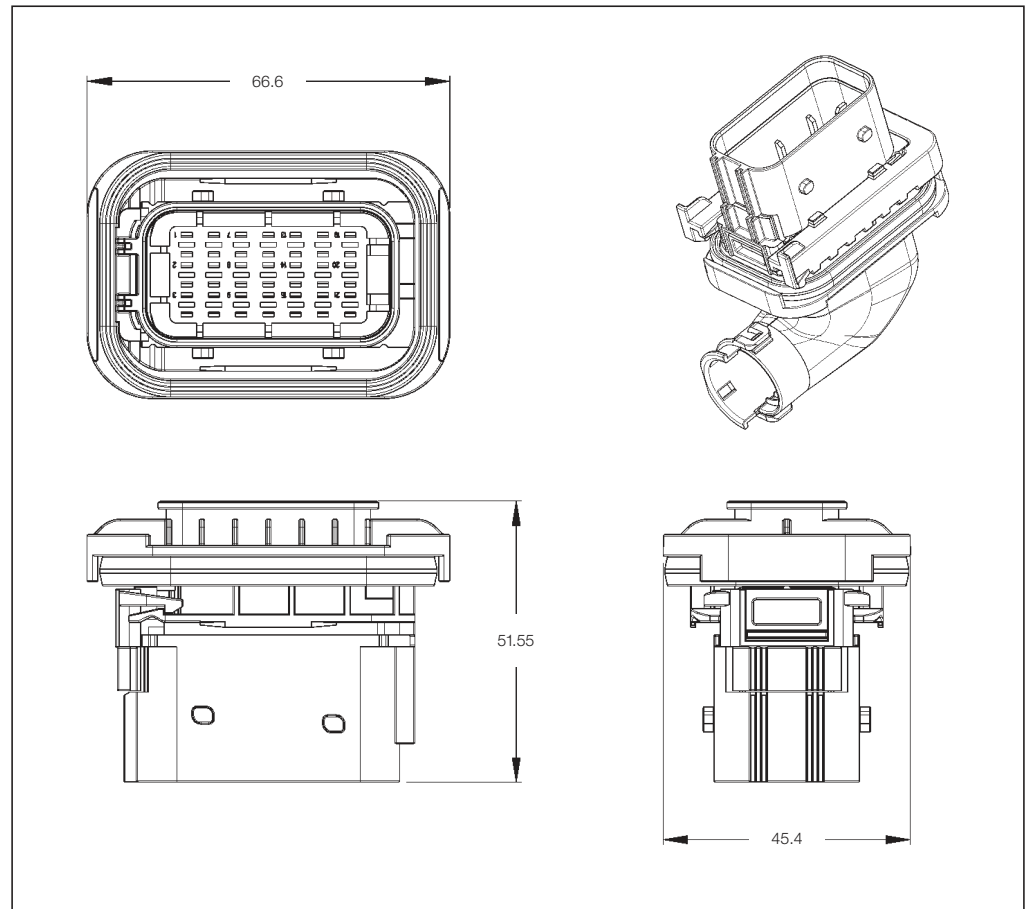

Sealed Tab Housings

No. of Positions	Keying Options	Housing Color	Part Numbers				
			Tab Housing with Flange	Cover	Interface Protection Cover	Locking Slide	Mating Receptacle Housing
21	A	Black	1-2112162-1	2112167-1	1-1394052-1	2112166-1 (2.5 mm)	1-1534127-1
	B	Natural	*)				2-1534127-1
	C	Blue	*)				3-1534127-1
	D	Violet	*)				4-1534127-1

*) On request.

Sealed 1.5 mm/2.8 mm/6.3 mm Tab Housings

Technical Features

No. of Positions:
26 Positions

Housing Material:
PBT-GF30

Wire Size Range:
12x 1.5 mm² FLR Max.
12x 2.5 mm² FLR Max.
AWG 12 TXL Max.
4x 6.0 mm² FLR Max.

Extraction Tools:
Part No. **1-1579007-1**
Part No. **1-1579007-3**
Part No. **1-1579007-6**
dependent on the contact

Product Specification:
108-94214

Application Specification:
114-94010

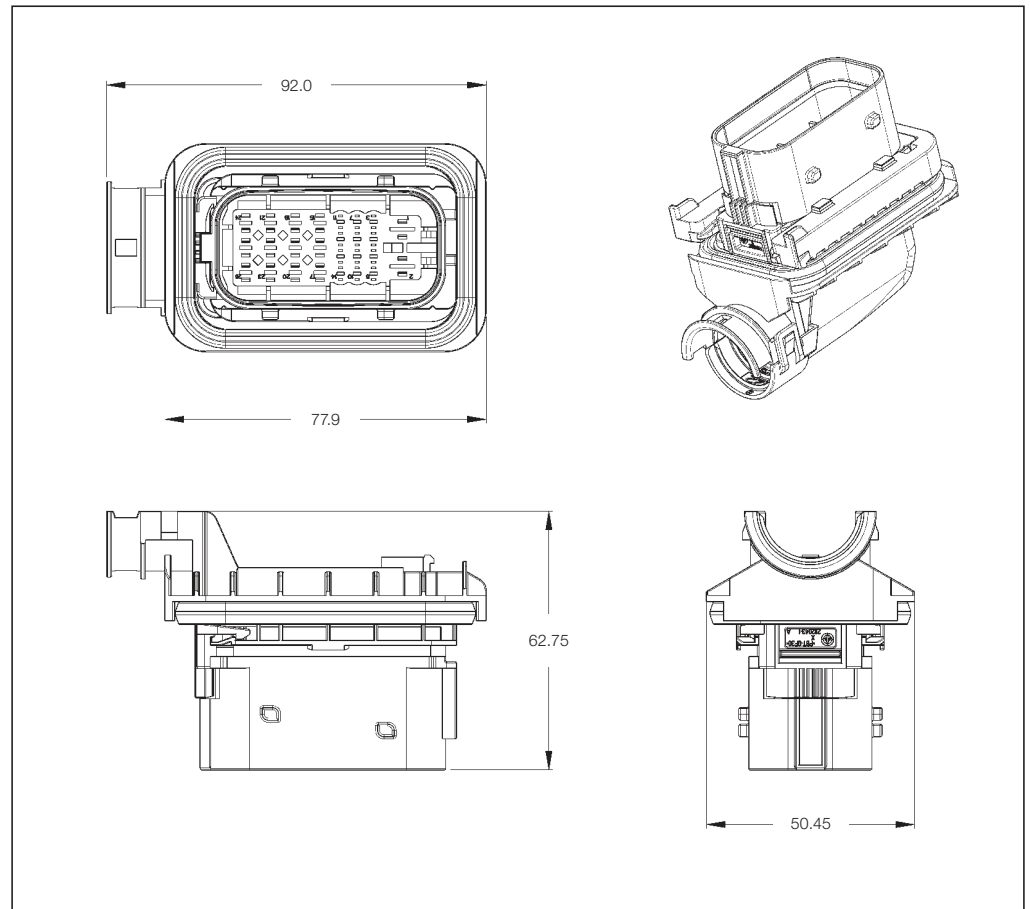

Sealed Mixed Tab Housings

No. of Positions	Keying Options	Housing Color	Part Numbers				
			Tab Housing with Flange		Cover	Locking Slide	Mating Receptacle Housing
26	A	Black	1-2112041-1	1-2112041-2	2112046-1	2112045-1 (2.5 mm)	1-2112035-1

Sealed 1.5 mm/2.8 mm Tab Housings

Technical Features

No. of Positions:

62 Positions

Housing Material:

PBT-GF20

Wire Size Range:

56x 1.5 mm² FLR Max.
6x 2.5 mm² FLR Max.
AWG 12 TXL Max.

Extraction Tools:

Part No. **1-1579007-1**
Part No. **1-1579007-6**
dependent on the contact

Product Specification:

108-18946

Application Specification:

114-18660

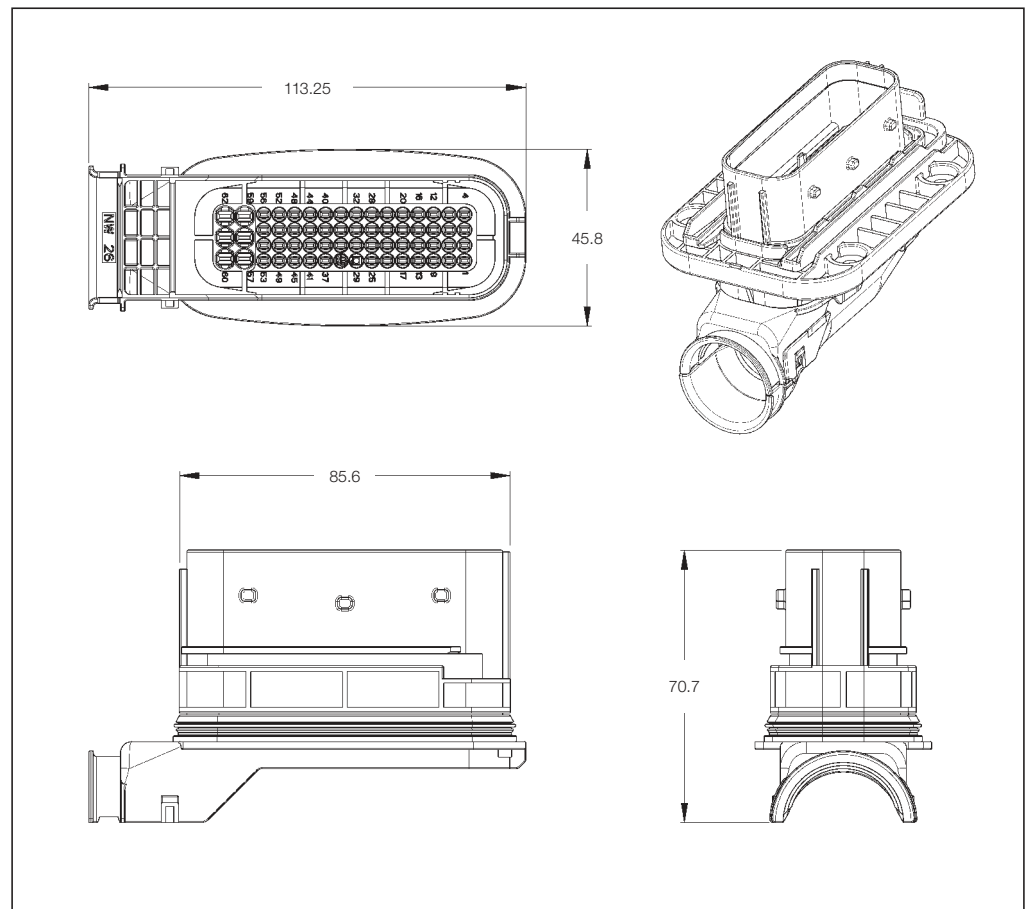

Sealed Tab Housings

No. of Positions	Keying Options	Housing Color	Part Numbers				
			Tab Housing	Cover	Adapter	Locking Slide	Mating Receptacle Housing
62	A	Black	1-1718324-1	1418882-1	1718329-1*	1718328-1	1-1418883-1
	B	Gray	2-1718324-1		1813123-1		2-1418883-1
	C	Blue	3-1718324-1		1813123-2		3-1418883-1
	D	Green	-		2138002-1		4-1418883-1

*) Unsealed.

Sealed 2.8 mm Tab Housings

Technical Features

No. of Positions:
39 Positions

Housing Material:
PBT-GF20

Wire Size Range:
2.5 mm² FLR Max.
AWG 12 TXL Max.

Extraction Tool:
Part No. **1-1579007-6**

Product Specification:
108-18946

Application Specification:
114-18660

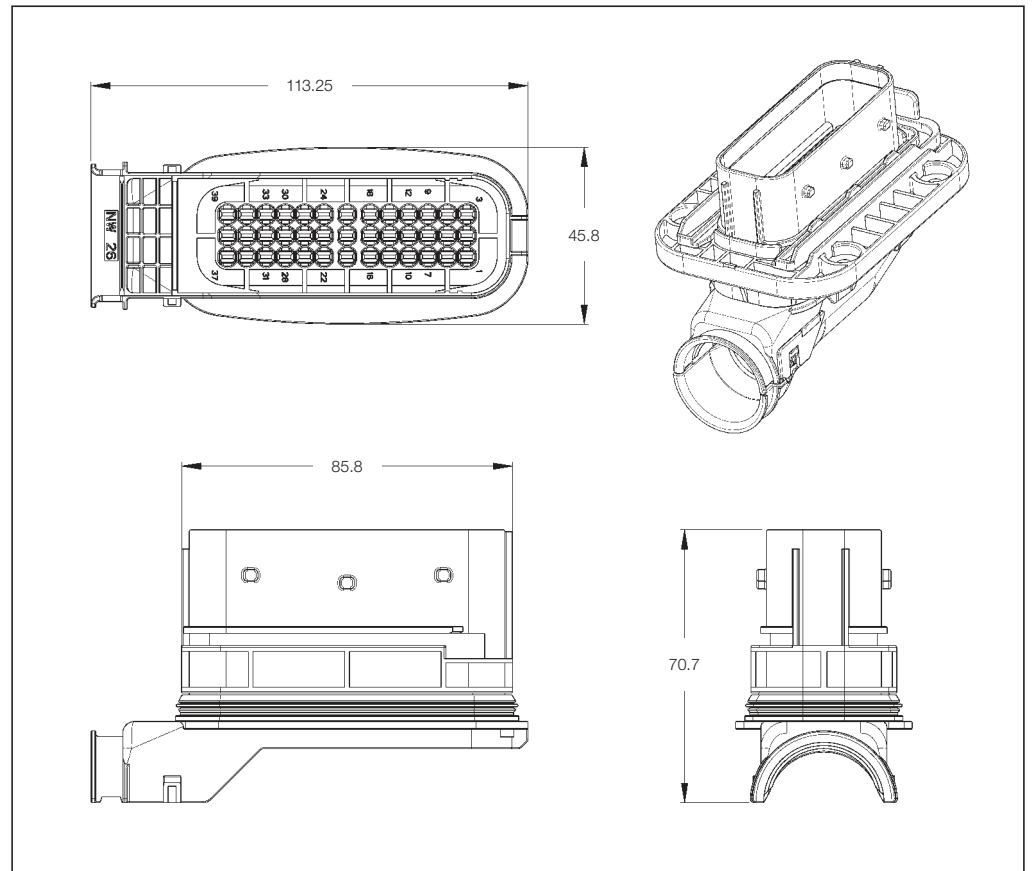

Sealed 2.8 mm Tab Housings

No. of Positions	Keying Options	Housing Color	Part Numbers				
			Tab Housing	Cover	Adapter	Locking Slide	Mating Receptacle Housing
39	E	Emerald Green	5-1718323-1	1418882-1	1718329-1*	1718328-1	5-1718321-3
					1813123-1		
					1813123-2		
					2138002-1		
	F	Fawn Brown	6-1718323-1				6-1718321-3

*) Unsealed.

Sealed 2.8 mm Tab Housings – PCB Headers

Technical Features

No. of Positions:
21 Positions

Housing Material:
PBT-GF20

Material and Finish:
CuSn, silver plated

Product Specification:
108-18696

Application Specification:
—

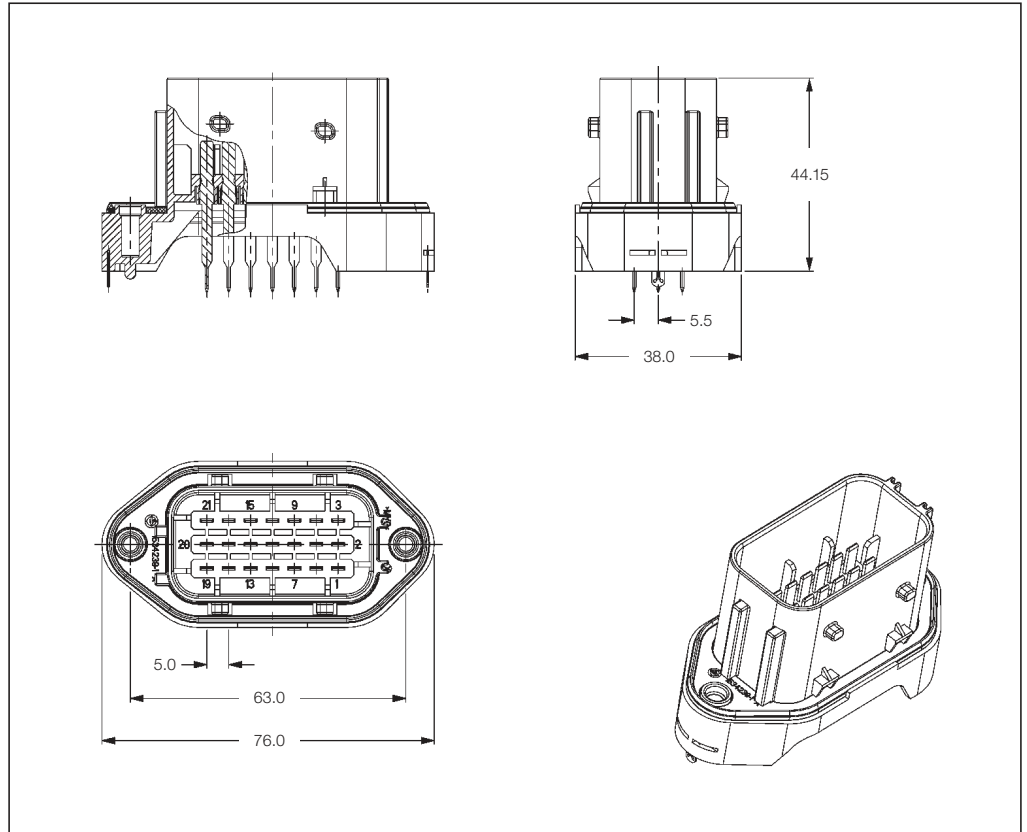

Sealed Tab Housings – PCB Headers

No. of Positions	Housing Color	Part Numbers				
		Vertical PCB Header	Package Quantity	Interface Protection Cover	Package Quantity	Mating Receptacle Housing
21	Black	1534238-1	105	1-1394052-1	250	1-1534127-1

Sealed 2.8 mm Tab Housings – PCB Headers

Technical Features

No. of Positions:
39 Positions

Housing Material:
PBT-GF20

Material and Finish:
CuSn, silver plated

Product Specification:
108-18946

Application Specification:
114-18660

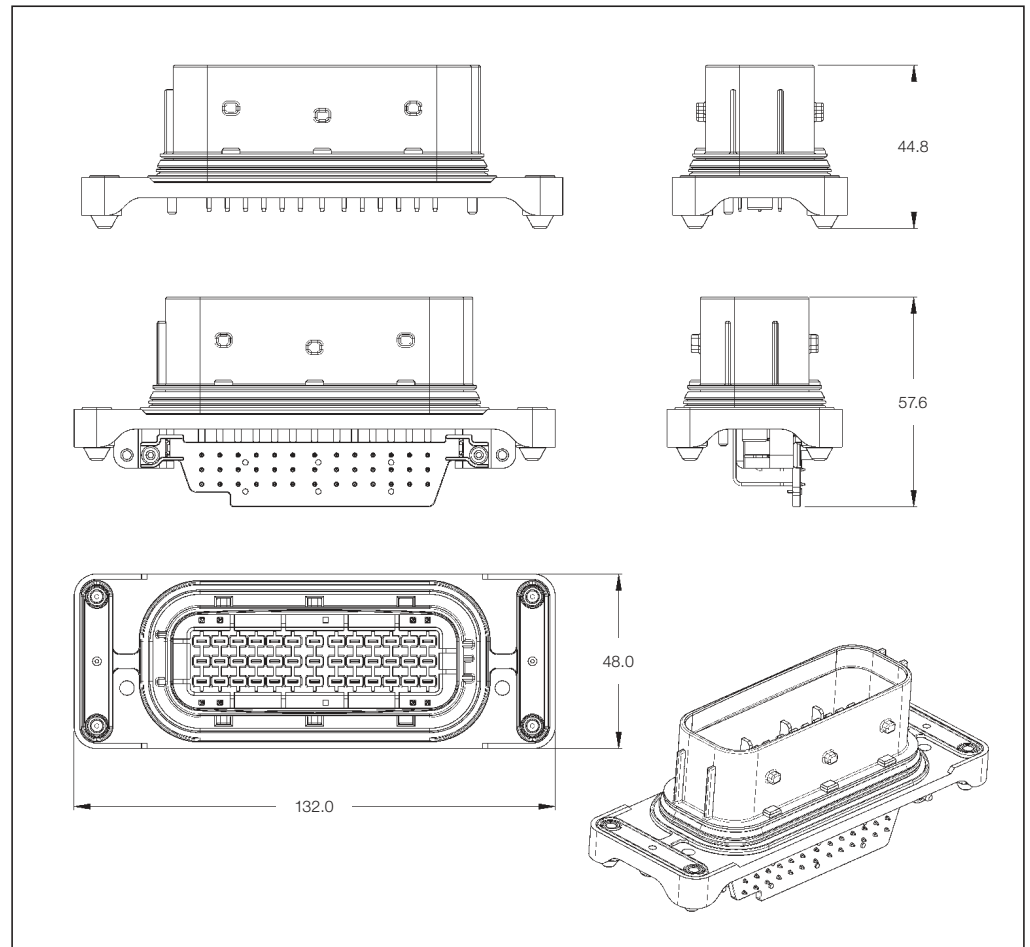

Sealed Mixed Tab Housings – PCB Headers

No. of Positions	Keying Options	Housing Color	Part Numbers		
			Vertical PCB Header	Angled PCB Header	Mating Receptacle Housing
39	E	Emerald Green	5-1418363-1	5-1418363-3	5-1718321-3

Sealed 1.5 mm/2.8 mm Tab Housings – PCB Headers

Technical Features

No. of Positions:

62 Positions

Housing Material:

PBT-GF20

Material and Finish:

CuSn, silver plated

Product Specification:

108-18946

Application Specification:

114-18660

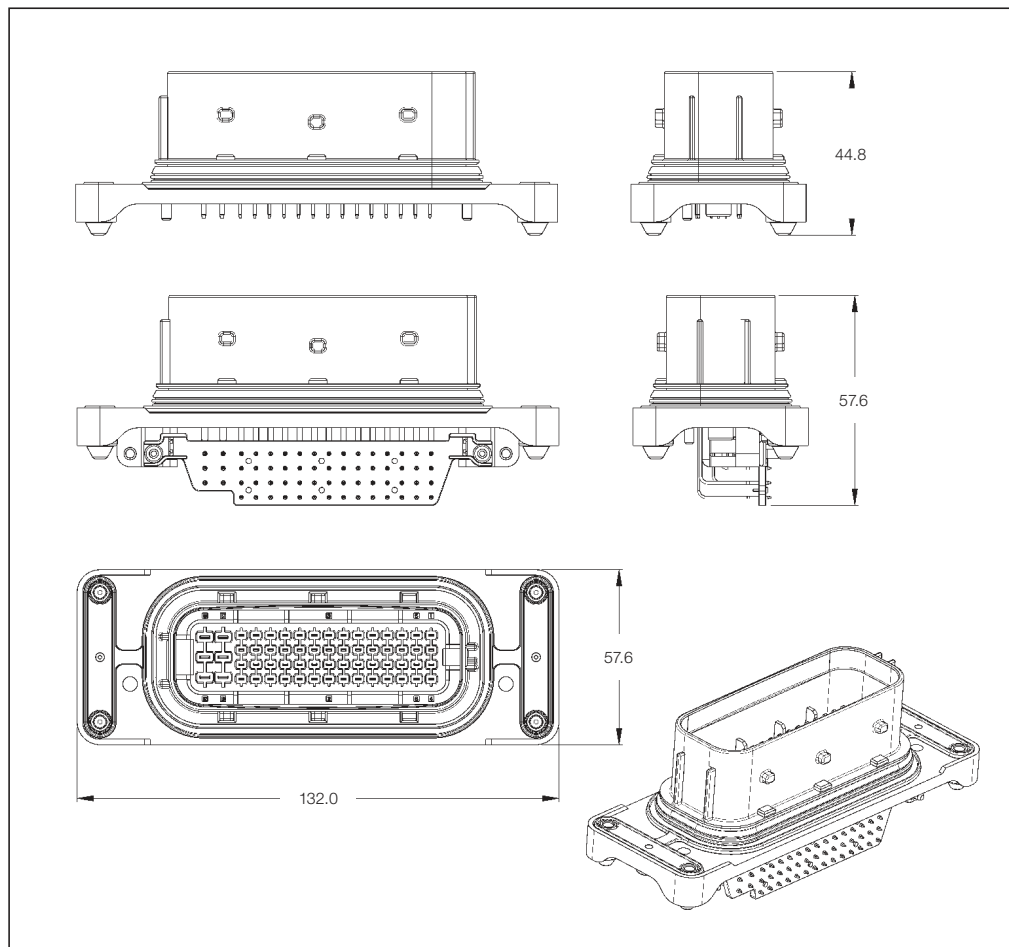

Sealed Mixed Tab Housings – PCB Headers

No. of Positions	Keying Options	Housing Color	Part Numbers		
			Vertical PCB Header	Angled PCB Header	Mating Receptacle Housing
62	A	Black	1-1418362-1	1-1418362-3	1-1418883-1 & 1-1823498-1
	B	Gray	2-1418362-1	2-1418362-3	2-1418883-1 & 2-1823498-1
	C	Blue	*)	*)	3-1418883-1

*) On request.

Sealed 1.5 mm Tab Housings – PCB Headers

Technical Features

No. of Positions:

92 Positions

Housing Material:

PBT-GF20

Material and Finish:

CuSn, silver plated

Product Specification:

108-94174

Application Specification:

114-18963

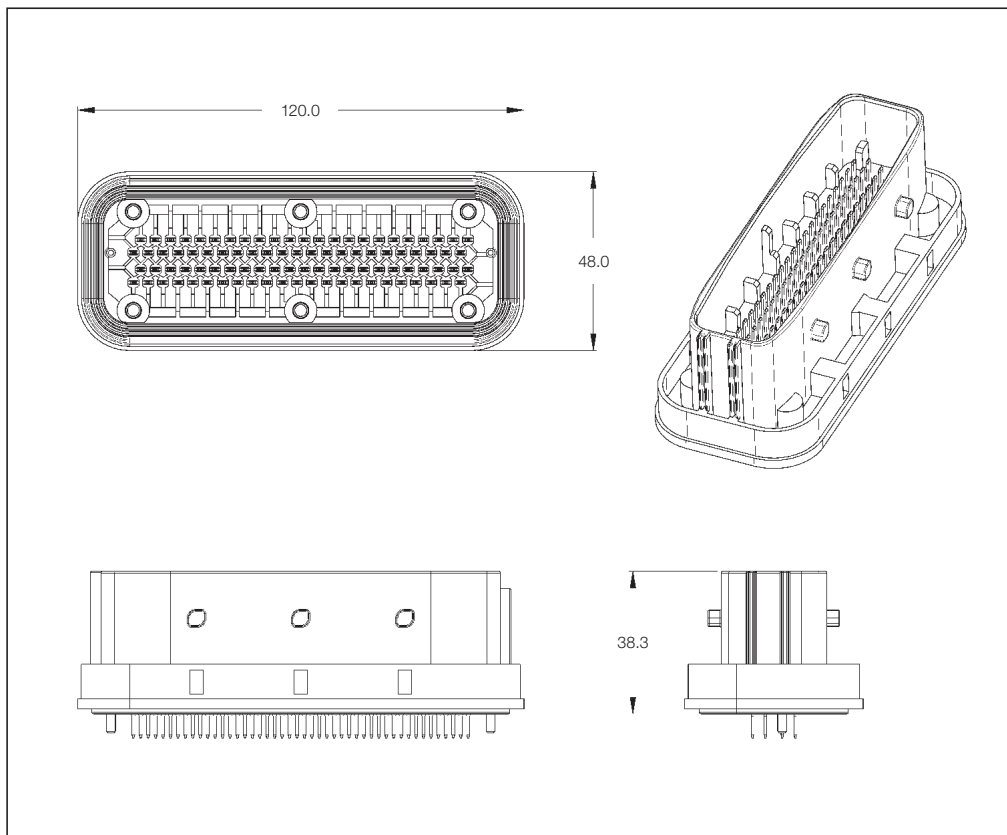

Sealed Tab Housings – PCB Headers

No. of Positions	Keying Options	Housing Color	Part Numbers		
			Vertical PCB Header	Package Quantity	Mating Receptacle Housing
92	A	Black	1-1452228-9	16	1703998-1

TE Connectivity Tooling for the Automotive Industry

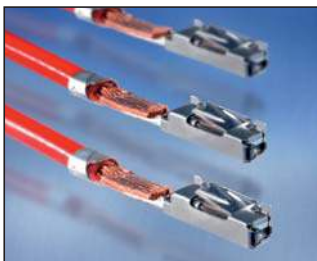

The TE Connectivity Application Tooling group is dedicated to providing high quality equipment options to meet all levels of your connector product specifications. We are also able to provide a broad range of equipment for other manufacturer's products.

Our equipment range is vast and unmatched by others operating in the same industry segments, as is our global presence and support network in the form of field service engineers and product managers. You will see from browsing this catalog; we supply everything from simple hand tools to the most complex automated systems – you name it, we supply it!

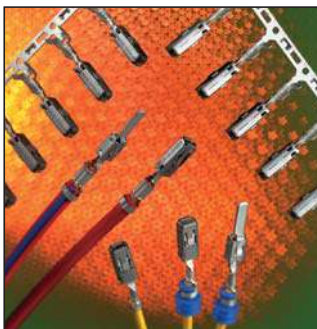

Equipment is segregated into two categories:

Generic Equipment

Where we can supply you with sufficient information referenced by Part Number such that you can identify and order what you need yourself.

Specialized Equipment

Where you will need help from our specialist product managers to identify what's just right for your application.

Finding Equipment Online

Powerful search functions are available to identify appropriate tooling:

- Applicators — www.tooling.te.com/europe/applicator.asp
- Hand Tools — www.tooling.te.com/europe/handtools.asp

Insertion Machines for Single Contacts

Pin Insertion Machine

TE Connectivity Insertion Machine platforms combined with performance enhancing accessories provide the flexibility to meet a wide range of customer requirements in the manufacturing of printed circuit boards.

Our goal is to provide the optimal solution for the production needs of our customers. Our representatives can help you select the optimal machine configuration. The benefit to you is a low cost investment that more than your requirements of output and quality.

TE Connectivity Field Service is available to service and support the machines to help maximize uptime. Our full line of Insertion Machines have been designed to deliver highest quality and maximum performance within their range of applications.

**P 100
Pin Insertion Machine**

The P 100 is a semi-automatic machine and the newest addition to the line of TE Connectivity pin insertion systems. Designed and manufactured with a focus on mid-volume level production, the P 100 machine provides a broad range of features at a very competitive price. With the ability to apply both TE Connectivity and other manufacturer's products, the P 100 machine does not limit your production to "TE Connectivity only" applications and provides flexibility to address both current and future tooling needs.

The P 100 machine uses a pneumatic power unit together with product specific "quick change" tooling packs. The Insertion heads can be supplied with a rotary insertion finger that can apply products at different angles without decreasing the insertion rate.

The tooling packs can be exchanged within 30 minutes to meet your full range of application requirements. The operator interface is an easy to use touch-screen which allows simple programming and automatic setup.

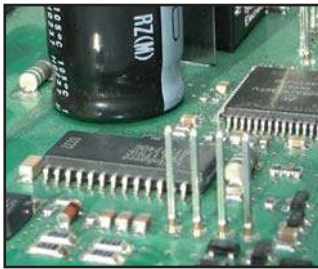

For more detailed information please visit our websites:
www.tooling.te.com • www.tooling.te.com/europe • www.tooling.te.com/china

Insertion Machines for Single Contacts

P 200 Semi-Automatic Bench Machine for PCB Processing

The P 200 semi-automatic bench machine positions manual loaded PCBs under an installed tool. The tool may be a solder head, a camera for automatic inspection, or an insertion head for the application of TE Connectivity products. Insertion tools for TE Connectivity products are composed of an insertion head (upper tooling), an anvil (lower tooling) and a product feeding mechanism.

These tools are product specific and the PCB holder interface is designed according to the customer application. A rotary insertion finger allows the insertion of pins at different angles. Because of simple

mechanical and electrical interface, other tools can easily be integrated into the machine. The excellent performance of a multi-tasking control system allows easy programming and operation of the machine.



P 300 Fully-Automatic Machine for PCB Processing

For the automatic assembly of printed circuit boards, the basic P 300 fully-automatic machine is equipped with a product specific insertion head. A speciality is the rotary insertion finger which allows the products to be inserted in different angles of rotation. A stepper-motor driven XY table positions the printed circuit boards under the insertion head. The control and monitoring of the insertion process is carried out by a multi-tasking control unit. There are three possibilities for programming the machines: off-line on a connected PC, by entering coordinates on the control panel of the machine

or by converting CAD data. A series of options also allows the P 300 fully-automatic

machine to be adapted to the most varied manufacturing tasks.

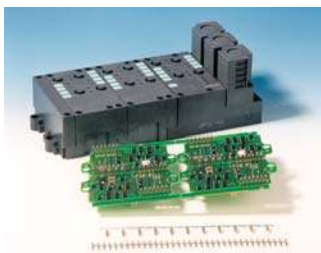

For more detailed information please visit our websites:

www.tooling.te.com • www.tooling.te.com/europe • www.tooling.te.com/china

Insertion Machines for Single Contacts

P 350 Fully-Automatic Insertion Machine for High Volumes

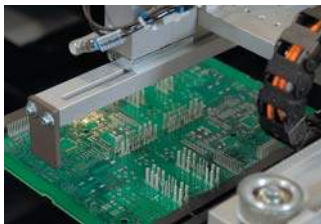
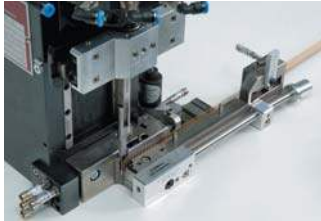

The P 350 is a fully-automatic insertion machine with the ability to handle a large variety of TE Connectivity terminals as well as customer specific terminals. A standard P 350 machine comes with 3 base insertion tools mounted onto an automatic tool changer. The tool changer can take up to 4 insertion tools/support tools. These base tools can easily be equipped with existing or customer specific conversion kits for a large range of terminals. All heads are equipped with rotary insertion fingers to allow the insertion of terminals at different angles without the need to rotate the board. The PCB transfer belts enable the machine to be incorporated into an automatic production line. A standard Insertion Force Monitoring system allows for real-time force monitoring for 100% quality assurance for each press-fit terminal. Its operator interface has been



designed for easy use and provides the insertion force and a variety of production data to be collected at an open interface. With a maximum insertion rate of 4.5 cycles per

second we provide a production capacity which is difficult to match in the market place. The programmable insertion of two 0.63 mm pins per cycle doubles the output.

Single Pin Repair Station



A loose-piece pin or tab is placed in the product specific insertion finger of the arbor press, the PCB is placed on the support anvil and the pin or tab is manually pressed into the board.



P 50 Manual Bench Insertion Machine

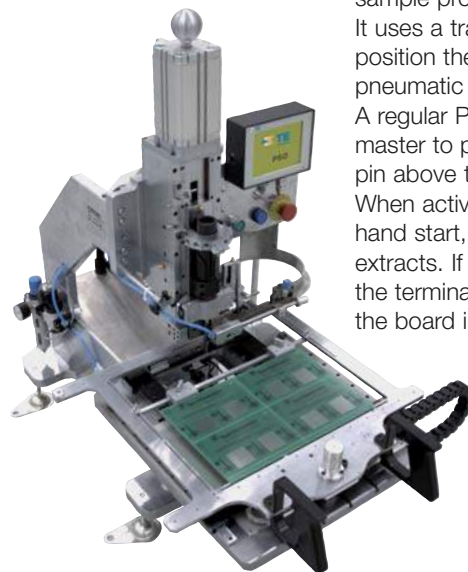

The P50 Insertion machine is a manual operated bench machine for low volume production, repair work and sample production. It uses a trader slide to position the PCB under the pneumatic insertion head. A regular PCB is used as master to position the indexing pin above the insertion hole. When activating the two hand start, the indexing pin extracts. If a hole is detected, the terminal is inserted into the board in production.

For more detailed information please visit our websites:

www.tooling.te.com • www.tooling.te.com/europe • www.tooling.te.com/china

IDC Machines

**IWS 188
IDC Workstation**



The IDC workstation produces electrical connections for harness assemblies specifically intended for the use within dashboard applications in the automotive industry. The proven insulation displacement technology ensures a high level of reliability. The software allows the production of different harness configurations featuring up to 11 connectors. The workstation is compatible with IDC connectors with a 2.54 mm and a 3.5 mm pitch. It is intended for medium to large volume production.



**MT-E2 F Semi-
Automatic Machine**

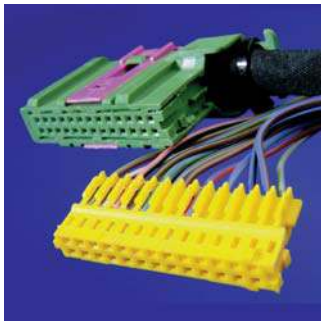

The development of this termination machine was necessary to be able to process high cavity-count female connectors in IDC technology. The new multi-cavity motor-control interface connectors are used in damp areas in cars and must be

completely water-proof, hence the use of a family seal over the insulation displacement contacts. The pitch of the cavities in the family seal corresponds to that of the connectors with their insulation displacement contacts.

The cavities in the family seal are closed by a membrane. An integrated programm controlled unit pierces the membrane, prior to the IDC termination.



For more detailed information please visit our websites:

www.tooling.te.com • www.tooling.te.com/europe • www.tooling.te.com/china

Lead Makers

Precision Controller

The new Precision Controller provides an upgrade path for already installed equipment. By installing the Precision Controller onto a bench terminator or a Komax Gamma 333 PC lead maker, the System III-FA Applicator can be used. An integrated LCD screen allows the user to view the information contained on the iButton™ data module and the controller also allows the operator to accurately position the terminal feed and make fine adjustments.



From the Precision Controller keypad, you can:

- Make fine feed adjustments
- Save the feed adjustments that were just made, or cancel them
- Perform full retraction or extension of the feed finger
- Perform a complete cycle of the feed finger

iButton is a trademark of Maxim Integrated Products, Inc.

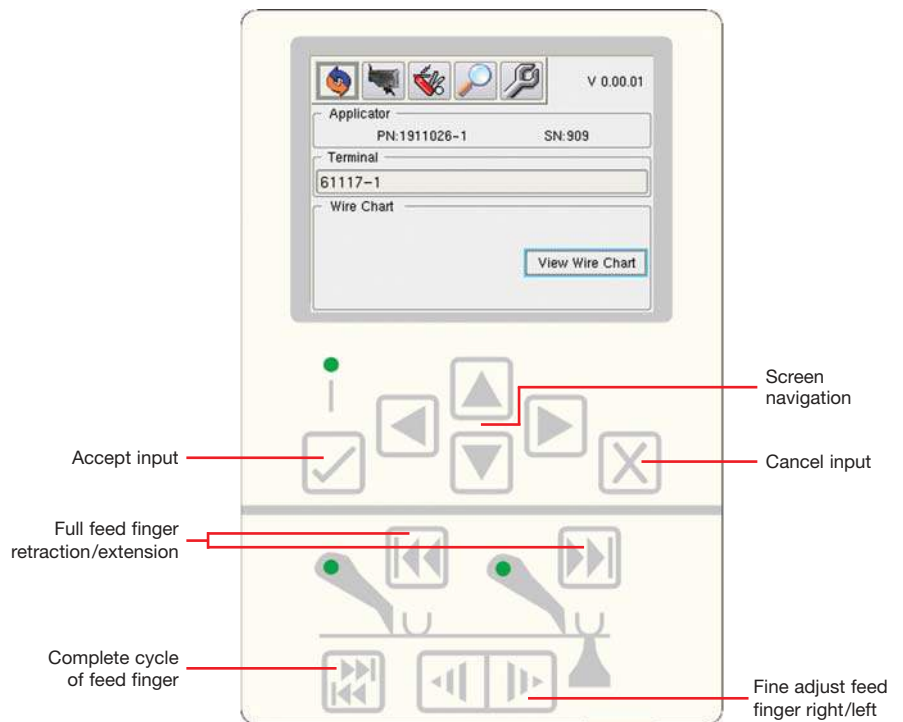

For more detailed information please visit our websites:

www.tooling.te.com • www.tooling.te.com/europe • www.tooling.te.com/china

Lead Makers

**Gamma 255
Lead Maker
Processing of
Small Wire Sizes**

The Gamma 255 Lead Maker is a flexible fully-automatic crimping machine for efficient wire processing. It processes cross sections in a range from 0.013 mm² up to 2.5 mm² in

excellent quality. The entire cross section is processed using programmable, highly dynamic servo-drives and V stripping blades. As part of its standard equipment, the

machine has a pre-feeder, splice, wire-end and knot detection, as well as two wire straightening units.

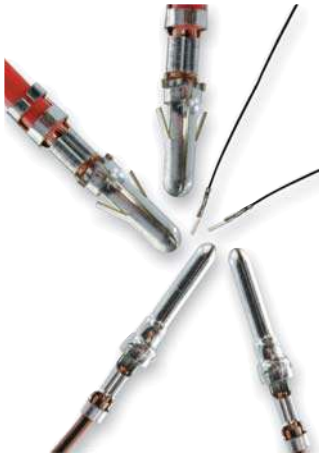

**Gamma 333 PC
Lead Maker Flexible
Wire Processing**

Ultra short conversion times, additional applications and a user-friendly interface with multiple-language capability. The Gamma 333 PC machine makes it all possible! With its additional processing station on side 1, the Gamma 333 PC machine now enables you to crimp both ends of the wire, to create double crimp connections with three

different contacts, to carry out one-ended seal application, tinning or ink-jet marking. In addition, process monitoring is integrated to ensure that

the wire is cut to length and stripped perfectly to specification and that quality control is optimized.

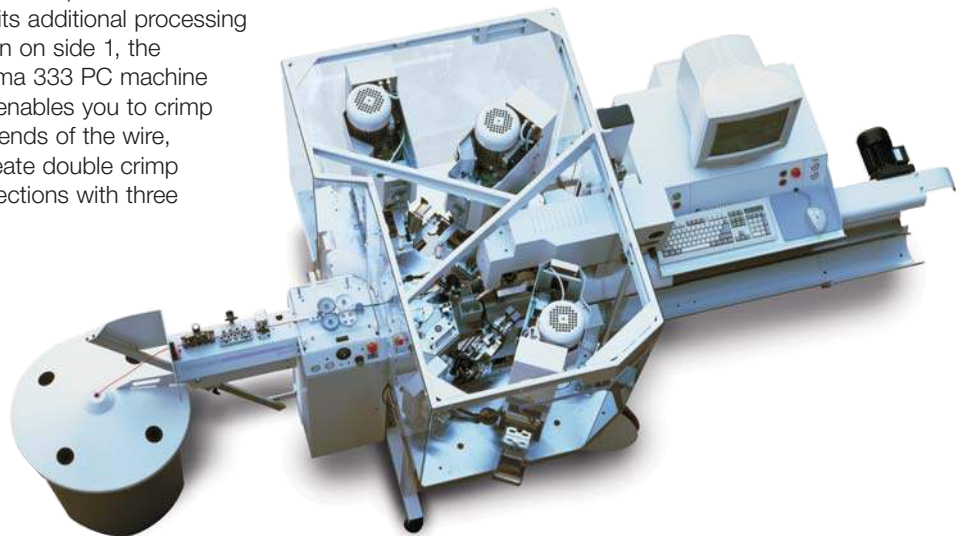

For more detailed information please visit our websites:

www.tooling.te.com • www.tooling.te.com/europe • www.tooling.te.com/china

Lead Makers

**Alpha 355/355 S
Lead Makers**

The Alpha 355 and 355 S are four Station Lead Makers. The dual channel cutting head allows for a large range of wire sizes without blade changes. The drive unit for the cutting head is positioned beneath the wire line to give the machine an uncluttered and ergonomic design.

All processing stations are readily accessible through the vertically opening safety covers. Applicators, terminal reels and other parts for specific applications can be changed without tools.

Controls are positioned locally, allowing the corresponding machine functions to be triggered during set-up. All setting and adjustment procedures can be controlled from the TopWin™ user software in over 20 different languages.



**Alpha 356
Multi-Functional
Fully-Automatic
Crimping Machine**

The Alpha 356 fully-automatic crimping machine has room for up to seven processing stations. A wide variety of configurations are possible, in fact, almost any combination of crimping, seal loading, fluxing/tinning, twisting, fitting with insulating sleeves and end sleeves for strands as well as bulk turned contacts and customer-specific processes.

The Alpha 356 is designed for using the broadest selection of different processing modules, including special customer-specific modules.



TopWin is a trademark of Komax AG

For more detailed information please visit our websites:

www.tooling.te.com • www.tooling.te.com/europe • www.tooling.te.com/china

Lead Makers

**Alpha 358
Fully-Automatic
Crimping Machine**

The Alpha 358 fully-automatic crimping machine is designed for two-sided crimping and seal loading and sets new standards in the processing of long cables. Cables up to

35 meters (27.34 yards) in length can now be processed at high speed on a machine just four meters (4.37 yards) long. Coiling and binding cables directly in the fully-

automatic crimping machine frees up substantial space and offers considerable quality advantages.



**Alpha 455
Fully-Automatic
Crimping Machine**

The Alpha 455 crimping machine is designed especially for just-in-time production. Downtimes become crucial for companies that produce relatively small production batches requiring frequent conversions of the machine. With the Alpha 455 machine, engineers set out to minimize the time lost on set-up and conversion while guaranteeing high quality standards.

The mci 722R is the product that guarantees the efficient set-up of the fully-automatic Alpha 455 crimping machine. This innovative new rotary press table was specially developed for the Alpha 455

machine and allows the latter to be converted while production is still going on. The tools and terminals for the next two jobs are set-up while the current batch is still being produced.

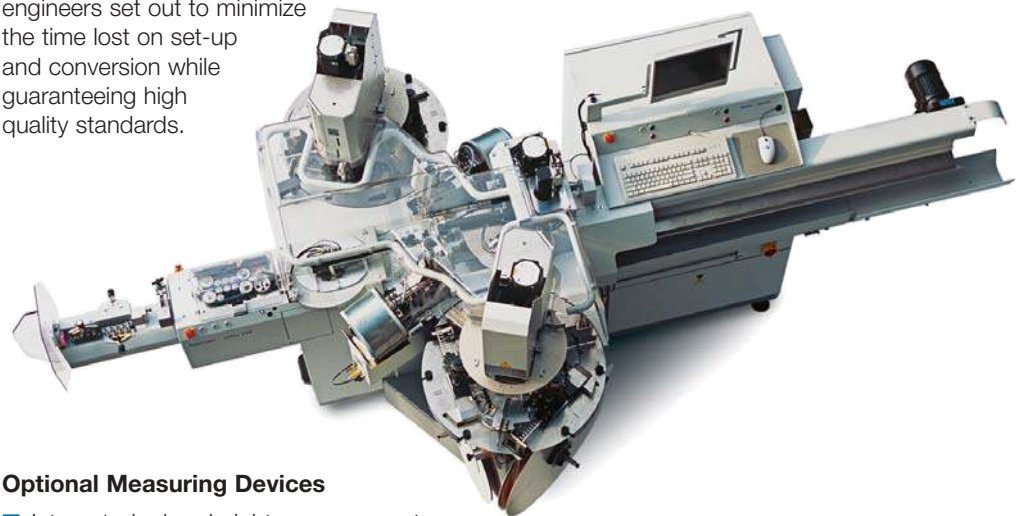

Optional Measuring Devices

- Integrated crimp height measurement
- Integrated measurement of pull-out force
- Integrated referencing of wire lengths

For more detailed information please visit our websites:

www.tooling.te.com • www.tooling.te.com/europe • www.tooling.te.com/china

Lead Makers

Alpha 477 Lead Maker
Double Crimp
Connections with
Two Different Wires

The Alpha 477 machine allows the processing of a wide variety of wire combinations from a double crimp up to three different contacts, two different seals and two different wire sections.

The arrangement of six processing stations plus a double gripper unit make for highly diverse processing possibilities. As a result, the Alpha 477 machine can grow and expand to meet your future needs.

Individual wires with cross section of 0.22 mm² up to 4 mm² can be processed. The maximum total cross sections of a double crimp can be as large as 6 mm².

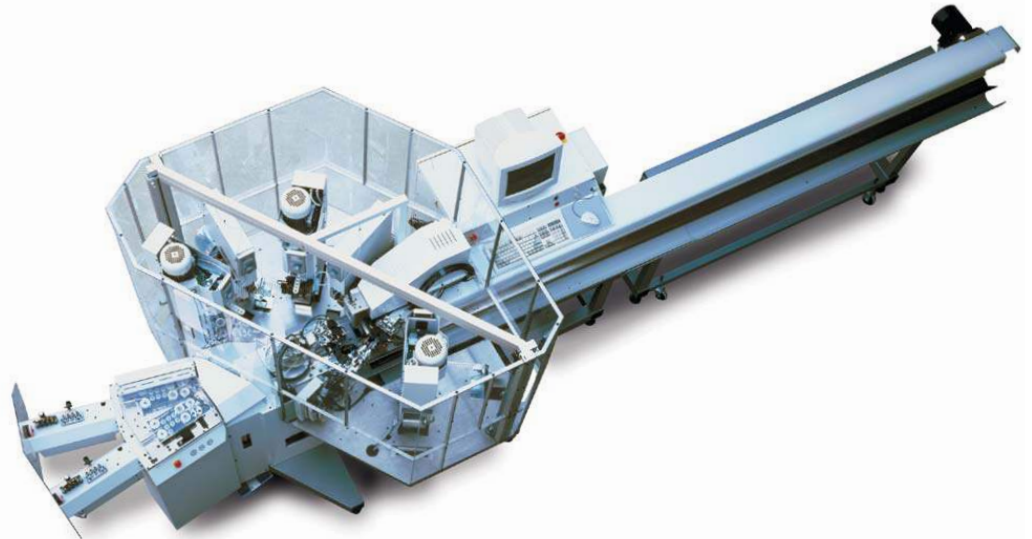

Alpha 488 Lead Maker
Processing of Twisted
Pairs

The Alpha 488 machine was designed for the economical processing of twisted pairs, consistently combining as it does state of the art technology with proven system elements like TopWin™ user-interface, the mci 712 or mci 722 crimp module.

The Alpha 488 machine creates fully processed twisted pairs from endless wire. This automatic twisting

machine can accommodate wires with cross sections of 2 x 0.22 mm² to 2 x 2.5 mm². Four stations on side 1 and

two on side 2 make for flexible processing possibilities such as double-ended seal application and crimping.



TopWin is a trademark of Komax AG

For more detailed information please visit our websites:

www.tooling.te.com • www.tooling.te.com/europe • www.tooling.te.com/china

Lead Makers

Zeta 633/633 L
Fully-Automatic
Crimping Machine

The Zeta 633 and 633 L are highly flexible fully-automatic crimping machines for just-in time production. The flexible machine concept creates an almost unlimited number of possibilities for handling small jobs or wire sequences. The operator is able to reduce the required material change-overs and interruptions in production to a minimum.

The Zeta 633 crimping machine is ready to accommodate five crimping presses and the 633L-Version can handle up to eight, for even more flexibility. Both Zetas can be used as stand alone machines with a bundler, as a basic machine for the block loader Zeta 651, Zeta 655 and Zeta 656 as well as for machines with an extension.



For more detailed information please visit our websites:
www.tooling.te.com • www.tooling.te.com/europe • www.tooling.te.com/china

Lead Makers

Zeta 651 Single End Block Loader

The Zeta 651 is the economical solution for the production of harnesses with single sided insertion in housings with one or two rows. This machine is especially characterized by a high degree of automation and the reliable insertion process.

The machine is used in combination with the flexible Zeta 633 base machine. By pre-centering the contacts, a reliable and precise insertion is guaranteed. By means of centering grippers, the contact can be centered and optionally rotated. The housings are feeded automatically and can

be refilled without any process interruption. An integrated force sensor performs force monitoring throughout the entire insertion process and enables a high insertion quality. Operation of the Zeta 651 is via the slide console of the Zeta 633 with the user software TopWin™.

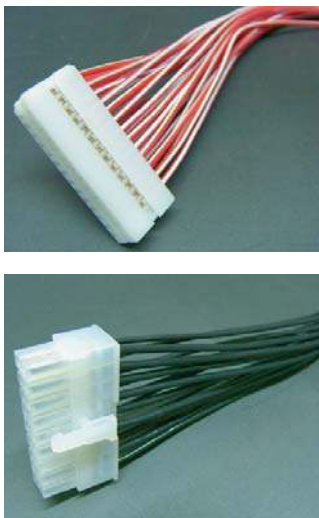

TopWin is a trademark of Komax AG

For more detailed information please visit our websites:

www.tooling.te.com • www.tooling.te.com/europe • www.tooling.te.com/china

Lead Makers

**Zeta 655 / 656
Lead Maker Double
End Block Loader**

The Zeta 655/656 Lead Maker is the flexible solution for single and double-sided housing insertion. This machine is characterized by a high degree of automation and a reliable insertion process. The precise force sensor monitors the entire insertion process to guarantee seamless, integrated process monitoring as regards

collisions, loading force and contact locking. The innovative quick change pallet system can replace the harness specific insertion application and convert to another harness. The Zeta 655/ Zeta 656 operates via the slide console of the Zeta 633 using TopWin™ software. The software automatically calculates the order of loading

within a wire harness to make the set-up of new harnesses as simple as possible. The fully-automatic Zeta 656 manufactures harnesses featuring conductor cross sections of 0.13 mm² and miniaturized housings with a pitch of 1.25 mm, doing so reliably and at high speeds.

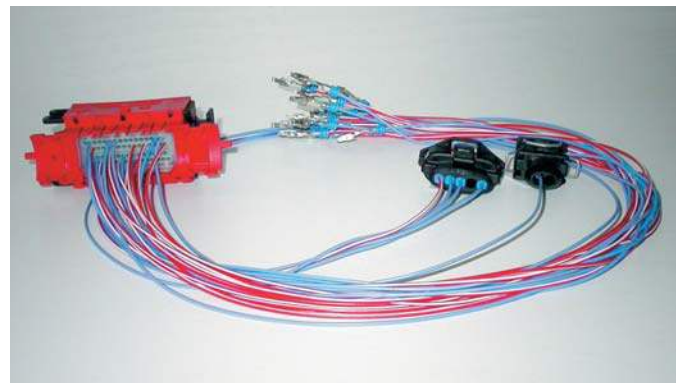
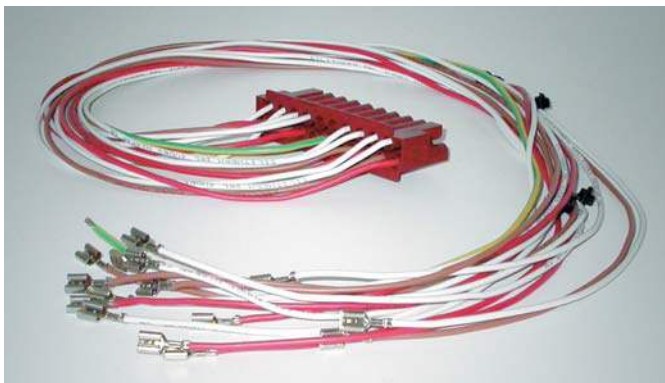

TopWin is a trademark of Komax AG

For more detailed information please visit our websites:

www.tooling.te.com • www.tooling.te.com/europe • www.tooling.te.com/china

Applicators

Ocean Series of Applicators

Why a new Applicator Design?

We standardized our applicator offerings to provide global design consistency and to offer you the ultimate flexibility with choices in feeding options.

The Ocean Applicators are designed so that all feed options are interchangeable with the common base applicator. Our pneumatic and mechanical feed options have been completely re-designed.

They offer finer and more precise terminal positioning along with quicker adjustability while being much more user friendly. The interchangeability also makes it possible to upgrade to System III technology.

Advantages of the Ocean Applicators

- One applicator platform — modular family design
 - Two styles with three feed options: Mechanical, Pneumatic and Servo
- Same wire crimper, insulation crimper and anvil used on both applicator styles
- Open architecture allows for design flexibility
- Featuring a re-designed ram to housing interface for improved alignment and crimp consistency
- Finer incremental crimp height adjustment
- Improved and simpler adjustments on all feed units
- Simple and tool-less wire and insulation crimp height adjustments
 - Fine Wire crimp height adjustment
Range = 0–1.5 mm
Total Increments = 0.01 mm
 - Insulation Adjustment

Range (mm)	Step Size (mm)
3.30	0.19
1.70	0.10
0.85	0.05

- Insulation step sizes are selected based on terminal application requirements
- Feed Types – Improved and simpler adjustments on all feed units
 - Mechanical – Micro-Feed Adjustments for forward and back strokes
 - Pneumatic – Incremental Adjustments
 - 0.04 mm forward terminal position
 - 0.08 mm back stroke adjustment
 - Servo – Push button terminal adjustments in 0.03 mm increments



Atlantic-Style SF Mechanical

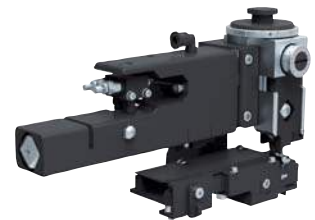

Atlantic-Style SF Pneumatic

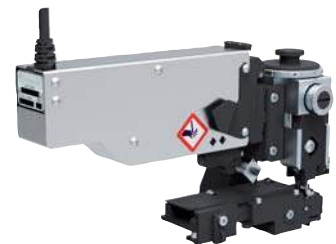

Atlantic-Style SF Servo



Pacific-Style Side-Feed Mechanical Applicator

For more detailed information please visit our websites:

www.tooling.te.com • www.tooling.te.com/europe • www.tooling.te.com/china

Applicators

**Applicator
Wear Parts**

**Applicator Wear Parts
Stocking Program**

To ensure the support of our installed Applicator base, we have established a stocking program for wear parts.

Subsequently, all crimpers and anvils for your applicator are normally available ex stock, ensuring the shortest possible lead times.



**Wear Tooling
to Apply Stainless Steel Contacts**

The application of nickel plated stainless steel terminals has always been a problem with regard to the uptime of the crimp tooling. We have developed crimpers and anvils, using special base

materials and surface treatments in the crimp area. These have enabled us to significantly increased the tool life and thus reduce the applied cost of these products.

If you are experiencing specific wear problems in your production, please contact your TE Connectivity Service representative.

For more detailed information please visit our websites:

www.tooling.te.com • www.tooling.te.com/europe • www.tooling.te.com/china

Applicators

System III Applicator with Feeder

Flexible and efficient termination of single and double wire applications, self-adjustment of the feeder and optimum quality of wire termination are the main features of our new applicator – the System III Applicator.

All crimp-related data, which are specific for the applicator and the terminal to be crimped, are contained in an iButton™, being part of the applicator.

The main feature of the System III concept is a separate electrical feeder – which is communicating with the applicator iButton on one hand and the terminator and leadmaker on the other hand – and an automatic interaction between applicator and terminator.

Once the applicator is mounted onto the press and as soon as the electrical

feeder (being permanently connected to the terminator) is locked onto the applicator, the applicator iButton data are read out and transmitted to the terminator via the feeder.

Then the terminator automatically adjusts its crimp height and the feeder its feeding parameters – according to the terminal wire combination to be crimped.

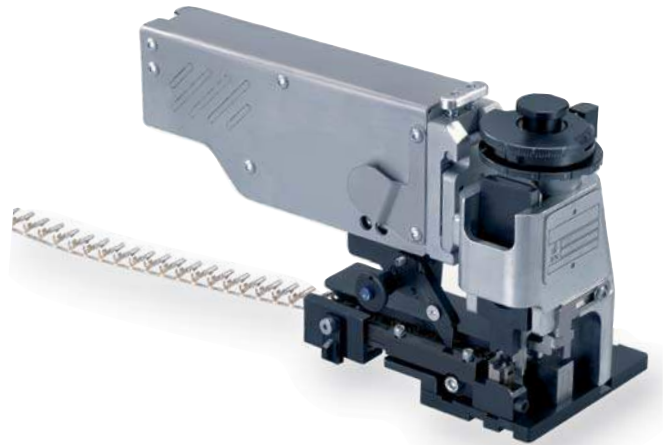

iButton is a trademark of Maxim Integrated Products, Inc.

Applicator for Large Wire Sizes

For processing of large contacts, eg. for battery terminals, we offer heavy and solidly built tools, which are extremely precise in repetitive work for end-feed and side-feed contacts with large cross sections.

A pneumatically driven feed which is efficient and precisely adjustable, as well as a specially robust crimping unit,

produce reliable connections which are extremely stable over the long term.

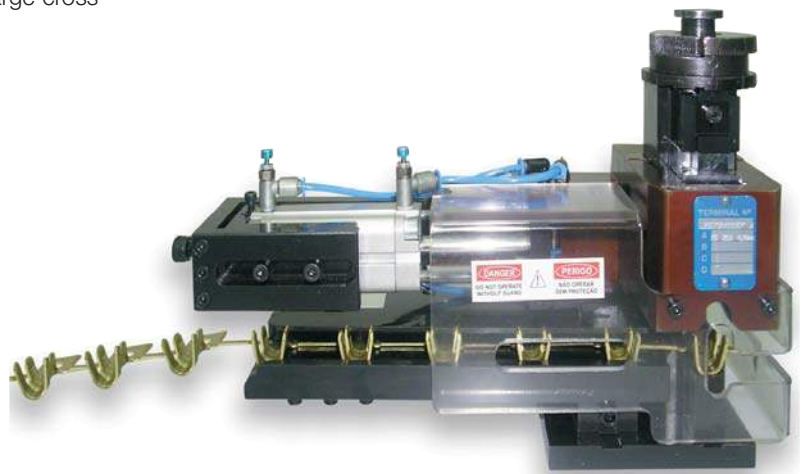

For more detailed information please visit our websites:

www.tooling.te.com • www.tooling.te.com/europe • www.tooling.te.com/china

Crimping Presses and Accessories

AMP 3K/40 and AMP 5K/40 Terminators

Based on the field proven Model "G" Terminator, the AMP 3K/40 and AMP 5K/40 Terminators are the latest in a series of machines for wire termination using reeled terminals.

The AMP 3K/40 Terminator provides 13 kN (3,000 lb) crimp force and is capable of crimping approx. 2.5 mm² (14 AWG) wire size.

The AMP 5K/40 Terminator provides 22 kN (5,000 lb) crimp force and is capable of crimping approx. 6.0 mm² (10 AWG) wire size.

As value oriented Terminators, the AMP 3K/40 and AMP 5K/40 are designed for customers that require the increased output and quality of a semi-automatic machine at a competitive price.

A wide range of optional equipment is available to meet your specific application requirements.



Stripping Module

The stripping module is compatible with AMP 3K/40 and 5K/40 terminators. A quick and flexible working process is supported by good accessibility to module adjustment and wire positioning. The stripping module was designed to produce good quality even used in the most harsh circumstances.

Following features characterize the stripping module

- Pre-selection Crimp only / Strip only / Strip and Crimp
- Jog Mode
- Pneumatic removal of insulation scraps

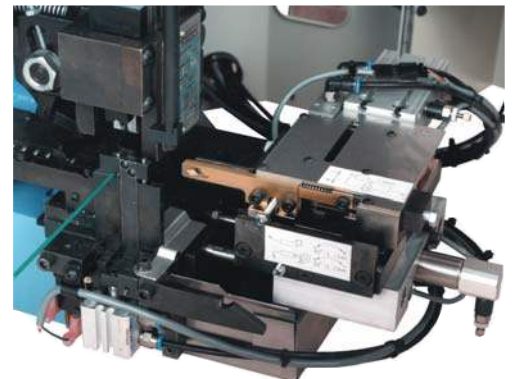

Defective Crimp Cutter (DCC) and Carrier Scrap Chopper (CSC)

When the CQM detects a bad crimp, the DCC unit will cut off the defective terminal. The wire will be cut close to the terminal.

- All DCC units are equipped with a Carrier Scrap Chopper (CSC).
- The DCC and/or CSC units can be easily hinged out of the way to allow easy access to change applicators.
- DCC provides more consistent wire placement accuracy capability due to the use of the grip jaws, compared to hand placing the wire in a terminator.
- DCC provides a scrap collection bin. It works with AWG 32-12 side-feed and end-feed HDM Style Applicators.

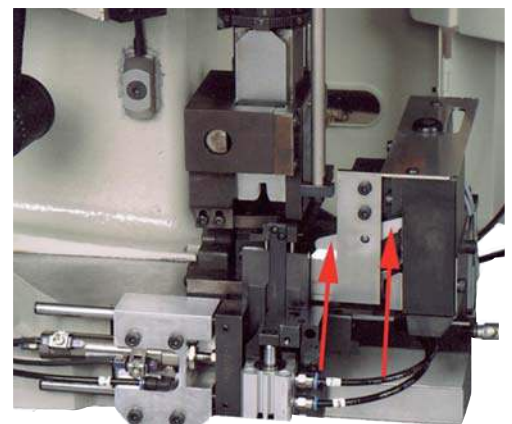

For more detailed information please visit our websites:

www.tooling.te.com • www.tooling.te.com/europe • www.tooling.te.com/china

Crimping Presses and Accessories

SC15 Stripper Crimper

The pneumatically and electrically driven SC15 crimping machine is a particularly efficient and operator friendly crimping machine with outstanding repetitive precision, which satisfies the highest requirements. It can be adjusted to the specific requirements of any given contact/cable connection.

If you

- want to strip a cable composed of many wires down to only 13 mm,
- would like to then insulate these single wires at 2 mm to 6 mm and thereby
- cover a wire size area of from 0.09 mm² to 4 mm² then with the Stripper Crimper SC15 machine you have made the right decision.

Further features are:

- Automatic bare wire recognition
- Crimp force monitoring
- Remote diagnoses via serial interfacespecific requirements of any given contact/cable connection.

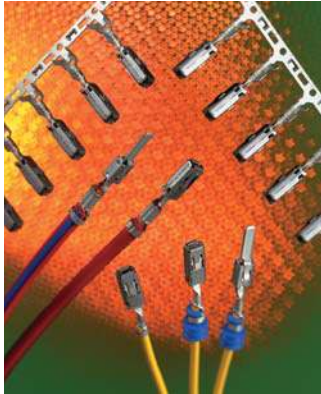

For more detailed information please visit our websites:

www.tooling.te.com • www.tooling.te.com/europe • www.tooling.te.com/china

Crimping Presses and Accessories

Crimp Quality Monitor II (CQM II)

Simply put, crimp height measurement is the best non-destructive way to ensure the quality of a crimped terminal. A proper crimp height ensures the mechanical and electrical properties of the crimp meeting the stringent application specifications designed by the terminal engineer.

Crimp Height is one of five different process analysis methods featured in the new TE Crimp Quality Monitor II (CQM II). The CQM II uses five different analysis methods to provide flexibility and ensure quality crimps are produced and faulty crimps are detected. New easy to use, intuitive menus along with enhanced monitoring and graphing lead the improved feature set of the CQM II.

Another major enhancement is the ability to use CQM II on non-TE terminators. This new unit can standardize and provide TE Crimp Quality monitoring across your production area by being versatile, precise and convenient.

- Real-time monitoring of every crimp
- Effective for monitoring the crimp of open barrel, uninsulated contacts and terminals.
- Calculation of actual crimp height and real-time graphic display
- Touch screen graphical user interface
- Multiple language support
- Power: 100–240 VAC, 50/60 Hz, 1.5 Amps (max)
- Engineered and manufactured using processes independently certified to internationally recognized quality standards

- Dimensions
Host Module:
170 mm (6.7") Width x
126 mm (5.0") Depth x
58 mm (2.3") Height

- Data Acquisition Module:
172.5 mm (6.7") Width x
101 mm (4.0") Depth x
48.4 mm (1.9") Height

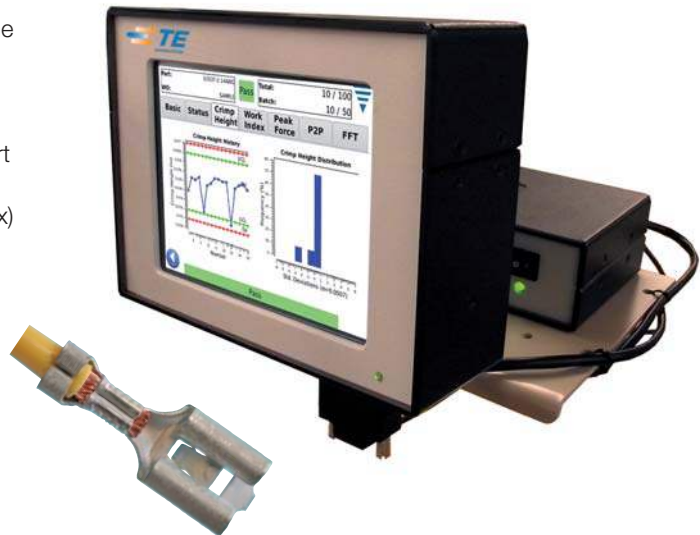

Production Crimp Height

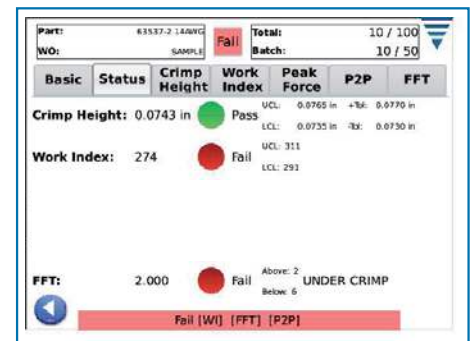

Basic Analysis Monitoring

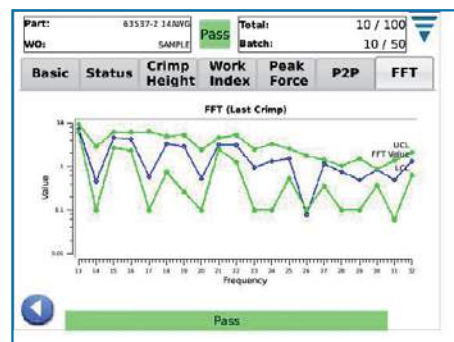

Fast Fourier Transform

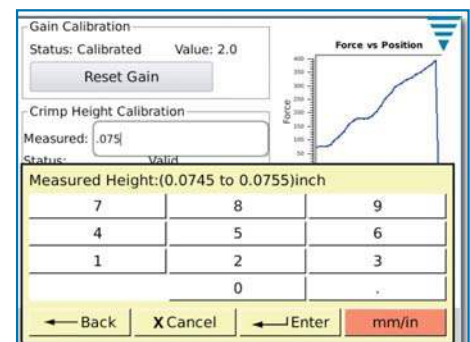

Crimp Height Entry

For more detailed information please visit our websites:

www.tooling.te.com • www.tooling.te.com/europe • www.tooling.te.com/china

Crimping Presses and Accessories

**BT 752 Stripping,
Sealing and Crimping
Machine**

The BT 752 crimping machine delivers three processes in a single device: stripping, seal loading and crimping.

Reliability and top production performance coupled with the user friendly TopTouch interface are the features that make this semi-automatic

device such a compelling product. The BT 752 crimping machine is an economical alternative to fully-automatic machines.



BT 711 Crimp Module

The BT 711 machine is a crimp module for the most demanding applications.

The module produces 20 kN, enough force to crimp wires up to 6 mm² in size, and is dimensioned to be compatible with all standard commercial crimping tools.

Options

- SC-11 Stripper
- Bad Terminal Cutter

Accessory

- CFA Calibration Unit



For more detailed information please visit our websites:

www.tooling.te.com • www.tooling.te.com/europe • www.tooling.te.com/china

Crimping Presses and Accessories

BT 722
Bench Top Press

The BT 722 Bench Top Press is used for the manual crimping of contacts. The BT 722 Press is operated from a touch screen. The new TopTouch user interface allows jobs to be set-up quickly and easily. Even during production set-up, the machine operator is prompted to conduct quality measurements. Following the input of the calculated values in the user interface, the crimp height is automatically corrected.

This prevents errors arising from the manual setting of the crimp height. Only one crimp is needed for referencing the integrated crimp force monitoring. This reduces waste material consumption and minimizes set-up time. The quality values measured during production are saved and can therefore always be called up later. This ensures traceable quality at all times.

The programmable DigiStripper (option) is an ideal accessory to the BT 722 Bench Top Press. This can be set-up without any mechanical adjustment. Thanks to the functions zero cut and pull back, as well as the pre-programmable cutting depth, the perfect stripping is ensured.



Gauge for Presses

In order to help you to ensure that our applicators are placed correctly in the presses we recommend this press gauge. It is possible to have a misalignment between the center of the applicator and the terminator due to the way they mount in the terminator. If this happens, a side load is applied to the applicator

which can lead to pre-mature wear and/or quality problems with the crimped terminals. The use of the gauge is simple: You install the press gauge into the press like an applicator. Then you unlock the gauge head, on which is mounted a gauge ring. A spring in the gauge is now pressing the gauge head

upwards. The gauge ring should now fit easily into the press head. If this is not the case the applicator ram would not be in a centred position and the mounting plate of the press has to be adjusted. The special design of the press gauge base plate allows free access to the press mounting plate fixing screws.

For more detailed information please visit our websites:

www.tooling.te.com • www.tooling.te.com/europe • www.tooling.te.com/china

Crimping Presses and Accessories

CRIMPATIC 970 and 971 Crimp Presses for Reeled or Loose-Piece Terminals

Both machine versions permit the cost effective manufacturing of crimp connections with a high production efficiency. The CRIMPATIC 970 machines are capable of processing wires of up to approx. 16 mm² (AWG 5), depending on the terminal stock thickness.

- Compact, space-saving design
- Compatible with MQC Applicators
- Step mode during set-up

The CRIMPATIC 971 machine is capable of processing wires of up to approx. 50 mm² (AWG 0), depending on the terminal stock thickness. The machines can be equipped with a quick change device for power crimp tools. MQC Applicators with a lower dead center of 135.78 mm can be mounted by means of an adapter plate. These machines can be utilized as manual work stations and can be integrated into fully-automatic processing lines.

The terminator as shown is a manual work station CRIMPATIC 971. The unit can be supplied with or without crimp process monitoring, or it may be retrofitted later.

Options are available upon request

- Crimp force monitoring
- Paper spooler
- Adapter plate for MQC Applicator

Applicators

- Especially designed for larger wire sizes
- Pneumatic feed
- Can be used with both crimp presses CRIMPATIC 970 and CRIMPATIC 971

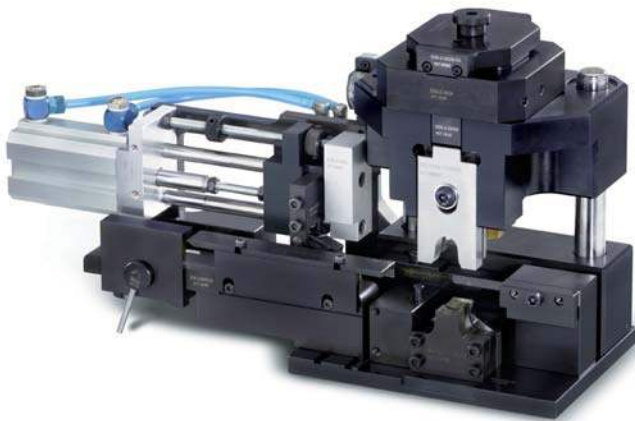

For more detailed information please visit our websites:

www.tooling.te.com • www.tooling.te.com/europe • www.tooling.te.com/china

Crimping Presses and Accessories

**AT-SC
Pneumatic Safety
Crimping Press**

This pneumatic crimping machine features a newly developed safety mechanism, and is designed to crimp connections up to 50.0 mm² depending on the terminal design.

By means of a fitted safety valve, crimping is not released where the size of the opening between the impact surfaces of the dies exceeds 5.9 mm.

Consequently, there is no need to specify any safety covers to protect the operator. The use of a safety double foot pedal simplifies the

operation while increasing productivity. This also allows the hands to remain free to insert the contacts and conductors.



**AT-55
Universal Pneumatic
Crimping Press**

This pneumatic crimping machine was designed for crimping insulated and non-insulated terminals from 0.14 mm² to 120.0 mm² depending on the terminal.

With the additional of an optional cutting unit, the AT-55 crimping machine is able to cut ribbon cable up to a width of 30.0 mm as well as copper conductors up to max. 28.0 mm diameter .

This series is equipped with a battery cycle counter. Safety guards allow crimp terminals up to a diameter of 25.0 mm. Larger terminals can be applied upon request.



For more detailed information please visit our websites:

www.tooling.te.com • www.tooling.te.com/europe • www.tooling.te.com/china

Crimping Presses and Accessories

**AT-66
Hydraulic Crimping
Machine**

The AT-66 hydraulic crimping machine features an extremely compact design resulting in low space requirement. The hydraulic power is provided by a separate hydraulic unit with main switch, power distribution and pump.

Our latest development offers possibilities for various applications with a crimp force of 150 kN and an open operating space of 100.0 mm in height. Typical applications are the crimping of terminals and connectors. This machine can be easily used for wire

sizes from 0.14 mm² up to 300.0 mm². A key operated switch protects the basic and operation data. It permits adapting and safeguarding the particular procedure for the application. The fitted memory module allows 250 different programs to be stored.

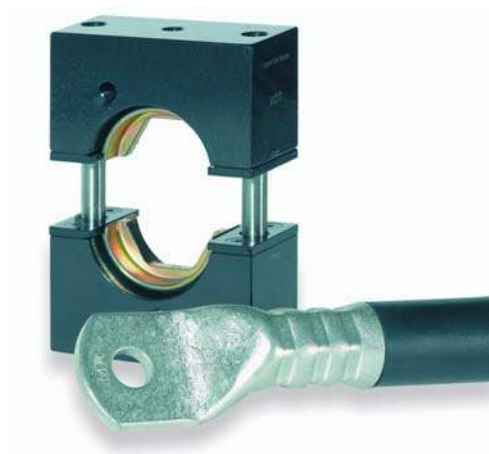

For more detailed information please visit our websites:

www.tooling.te.com • www.tooling.te.com/europe • www.tooling.te.com/china

Crimping Presses and Accessories

**StripCrimp PP3
Stripping and
Crimping Machine**

Extremely fast stripping and crimping of wires down to a wire cross section of 0.012 mm², minimum strip lengths and a most compact overall design are the special features of StripCrimp PP3 machine, which is controlled and powered pneumatically. To ensure the required precision, the PP3 machine incorporates a toggle press,

allows adjustable wire zero-cutting and can be equipped with an optional crimp force monitoring system in order that optimum crimp quality is assured.

User-friendly design, fine adjust of stripping and crimping parameters and easy-to-handle wear part change are key features of the PP3 machine as well as

a small footprint and compact size allowing it to be used in many working areas.

We offer a PP3 solution for end-feed and side-feed terminals, de-reeling from right to left or from left to right.

Efficient after sales support includes a ready availability of wear parts.



**CoaxStrip 5300
Programmable Coaxial
Cable Stripping
Machine**

The CoaxStrip 5300 machine is a semi-automatic, programmable multi-step stripping unit for coaxial, triaxial, multi-conductor cable and single conductor wire.

This benchtop unit can easily process coaxial and triaxial cables up to 7 mm (0.276") outer diameter and strips lengths up to 30 mm (1.18").



For more detailed information please visit our websites:

www.tooling.te.com • www.tooling.te.com/europe • www.tooling.te.com/china

Crimping Presses and Accessories

AT-ST Cable Strip and Twist Machine

The AVG 0160 is a stripping and twisting machine for wires with insulation such as PVC, Teflon™, Silicon, Fiberglass, Rubber etc. The machine can cover a wire size range from 0.03 mm² up to 6 mm² with an adjustable stripping length from 0.5 mm up to 29 mm. The machine utilizes rotary stripping blades for a smooth, 360° cutting of the insulation.

The blades are made out of a special tool steel for longevity. Optionally available is a spring kit for tighter twisting of the strands suitable for additional tinning operation.

Teflon is a trademark of E.I. DuPont de Nemours and Co.



JacketStrip 8400 Jacket Stripping Machine

The JacketStrip 8400 stripping machine enables automatic jacket stripping of round cables up to 26 mm in diameter and a stripping length of 200 mm. After the cable jacket has been cut, the piece of insulation is removed using a strong electric motor (full/partial or window strip can be selected). Pneumatically

operated clamping jaws guarantee optimal cable retention during the stripping process. Waste insulation material is automatically ejected. All functions of the machine are electronically monitored and diagnosed by means of a LCD display.



UniStrip 2015/2100 Stripping Machines

The pneumatically operated stripping machine UniStrip 2015 excels with a compact design, fast cycle times and infinite settings for conductor diameters, stripping and pull-off lengths. The UniStrip 2015 stripping machine primarily processes stranded wires and single wires. Due to the minimal distance between the acrylic safety cover and

the stripping blades, this machine can perform stripping on extreme short cables. The UniStrip 2100 is an electrically driven stripping machine. Ease of operation, fast cycle times, a powerful yet silent motor drive as well as a vast cable processing range are the main features of this machine.



UniStrip 2500 Stripping Machine

This pneumatically driven stripping machine comes standard with V-blades, the optimum solution for any ordinary stripping of stranded wire with no blade changeover necessary. Through the use of special blades, the range of applications can be expanded to include flat ribbon cable,

double-stranded wire, thin multistranded wire or demanding (though, delicate, thin) isolations. The adjustable way-back prevents the conductor from being damaged during the stripping process.



For more detailed information please visit our websites:

www.tooling.te.com • www.tooling.te.com/europe • www.tooling.te.com/china

Crimping Presses and Accessories

Kappa Cut and Strip Family

The Kappa family strippers are ideal for cutting individual and special wires to length and stripping them. They can strip in sections, allowing them to strip even extremely long length in perfect quality. The machines cover an extraordinarily broad range of cross sections.

Kappa 310, 320, 321, 330 and 350 strippers support a variety of processing options such as wire marking with hot-stamp or ink jet markers. Hot stamp marking can even be done on the Kappa 310 stripper, the entry-level model.

New Kappa Generation:

- Dynamic, flexible cutting and stripping unit
- New intelligent sensors
- New electronic and software
- Optional TopWin™ connection



TopWin is a trademark of Komax AG

For more detailed information please visit our websites:
www.tooling.te.com • www.tooling.te.com/europe • www.tooling.te.com/china

Resistance Welding Equipment

Resistance Welding Module

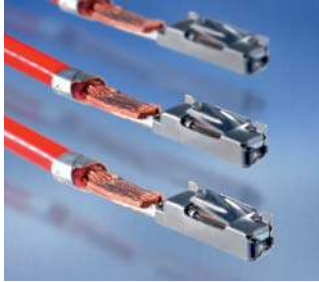

TE Connectivity offers semi- and fully-automatic modules for resistance compact welding of terminals. This resistance welding process allows us to achieve minimum transitional resistance between conductor and contact, higher current capacity and long-term stability of the wire termination.

In this process, the bundle of strands in the conductor is condensed into a block by side-mounted ceramic plates. After this the strand bundle is welded to the contact by the introduction of a powerful current via an electrode.

Typical features of the resistance welding unit offered by TE Connectivity are a very short cycle time, a long electrode life time, a fully-automatic parameter setting process and the recording of all process relevant data.

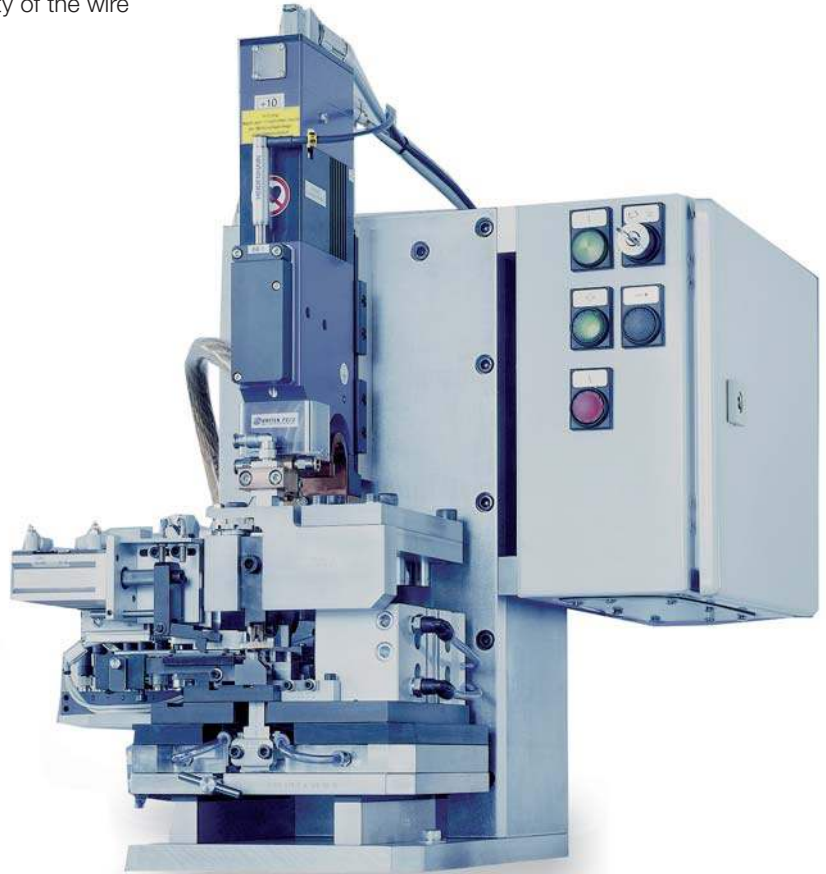

K1: I [kA]	K1: s3 [µm]	PROG
MAX GW 140.0	107.0	01
MIN GW 80.0		EINZEL
		DAUER
		LOGGER
		MENU
		PARAM
		ANALYS
		DAUER

HAUFRUF KONFIGURATIONSMENU

Labels: Electrode, Ceramic Walls, Current, Weldered Connection

For more detailed information please visit our websites:

www.tooling.te.com • www.tooling.te.com/europe • www.tooling.te.com/china

MOST™ Equipment

**Lambda 9100 POF
Fully-Automatic
Processing of MOST™
Leads**

For processing large quantities of plastic optical fibers (POF) with low human recourse, TE Connectivity offers the fully-automatic machine Lambda 9100 POF. All processing steps – from feeding and preparation to

testing and deposition – are fully-automatic. Functions like length measurement, integrated marker software and monitored laser welding are available and guarantee consistently high quality.

To ensure gentle handling, the fiber ends are held fixed throughout the process so that no uncontrollable bending radius occurs. The Lead Maker is equipped with a Dual Laser Module.



MOST™ Sets

The MOST™ Sets are simple and inexpensive solutions for repair work in the workshop. To meet your requirements we offer several different versions of Sets. The basic version is equipped with two hand tools.

One for stripping and cutting of POF, another one for crimping of POF and an additional spare cutting unit. A further version contains such items as a 20 meters POF, some male and female

contacts and one position inline couplings. Other accessories are available in different equipment versions.



MOST is a trademark of
SMSC Europe GmbH

For more detailed information please visit our websites:

www.tooling.te.com • www.tooling.te.com/europe • www.tooling.te.com/china

MOST™ Equipment

MOST™ Measuring Devices

These devices measure the position of the prepared end of the optical fibers relative to the reference point of the insert extremely accurately.

The result is displayed clearly by means of the digital read out. The digital display can be zeroed by means of the setting gauge.

A special Digital Crimp Height Micrometer verifies the crimp height of metal inserts. Two opposed probe tips measure the crimp height of the inserts across the diameter.



Tooling and Equipment for Glass Fiber Optics (GOF/PCS) for Automotive

In the future Glass Fiber will be used in the automobile industry. To keep pace with this trend TE Connectivity is developing process equipment for the manufacture of GOF and PCS leads. Developments are based on experience gained in processing plastic and glass

fiber for NETCONNECT communication technology products. With both GOF and PCS the primary obstacle in the process is to achieve a high quality fiber end surface. The goal of our development is to process the PCS fiber end with a Laser Module.

Further process involve joining a connector to the fiber end with a Laser welding Module. The manufacture of the GOF fiber end faces involves additional process of heat forming and polishing. A Laser Module is used finally to accomplish optical connector assembly.

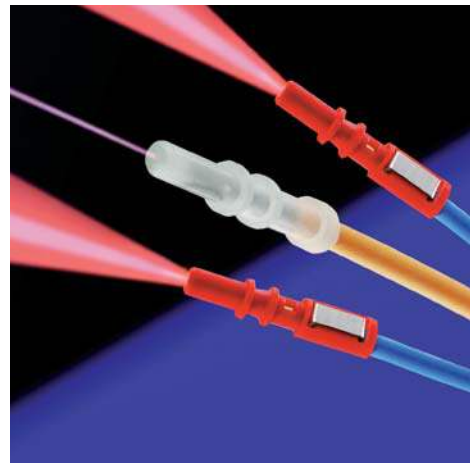

MOST is a trademark of SMSC Europe GmbH

For more detailed information please visit our websites:

www.tooling.te.com • www.tooling.te.com/europe • www.tooling.te.com/china

Hand Tools

SDE Standard Die Envelope

SDE die system is a flexible approach to crimp tooling that allows the use of the same dies with tooling across a range of application platforms. A large selection of die options are already available for crimping a broad range of terminals and wire sizes.

Many die sets have multiple cavities for crimping more than one wire or terminal size and we can provide custom designs where volumes permit.



SDE Crimp Tools

SDE dies are interchangeable in tools from portable hand tools (manually or battery-powered) to pneumatic hand tools and electric bench terminators.

It's a family of tools that you can take from bench to production or into the field, without the need for different dies to fit each kind of tool.

You can rely on SDE dies to provide for your long term needs because of our commitment to continued development of dies and the tool range.



For more detailed information please visit our websites:

www.tooling.te.com • www.tooling.te.com/europe • www.tooling.te.com/china

Hand Tools

IDC Hand Tools

IDC or Insulation Displacement Crimping is based on an entirely different concept to conventional crimping and requires these special types of tool.

We provide a large range of tools for connector families like:

- MQS Connectors,
- AMP DUOPLUG,
- AMP MONO-SHAPE and
- AMP multifitting

and usually based on the well proven Pistol Grip tools, featuring connector holding fixtures that crimp and index one pitch at a time.



For more detailed information please visit our websites:

www.tooling.te.com • www.tooling.te.com/europe • www.tooling.te.com/china

Hand Tools

Hand Tool Kits

TE Connectivity provides standard kits that contain the necessary equipment to carry out specific tasks to the highest professional standards.

We can also provide custom kits for volume requirements containing only tools, or a combination of tools and terminals tailored to your specific requirements.

Please visit our tooling website to view our online hand tool catalog for standard kits, or find your local contact to discuss custom kits.



For more detailed information please visit our websites:

www.tooling.te.com • www.tooling.te.com/europe • www.tooling.te.com/china

Hand Tools

Hand Tool Kits

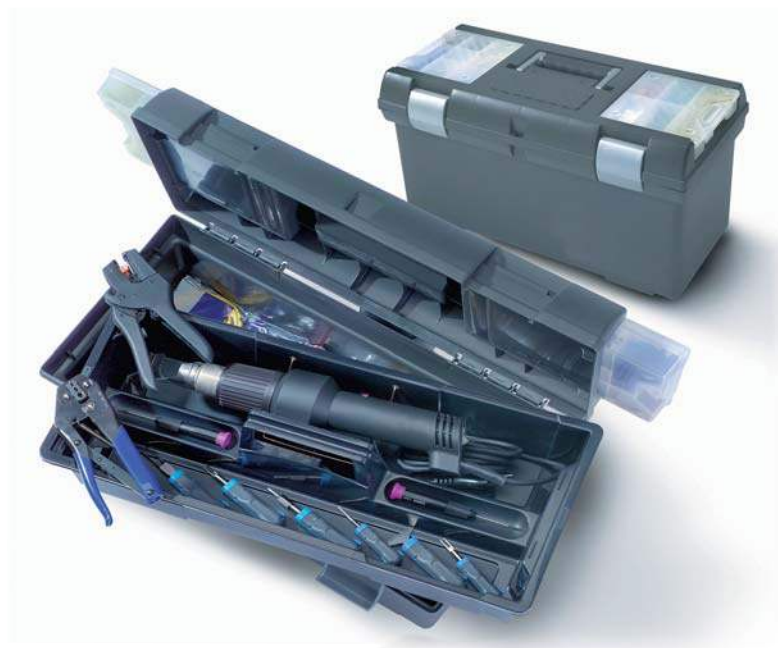

For more detailed information please visit our websites:
www.tooling.te.com • www.tooling.te.com/europe • www.tooling.te.com/china

Hand Tools

**Insertion and
Extraction Tools**

Insertion and Extraction Tools are used for inserting discrete terminals into connector housings or removing them, without causing damage to either the terminals or housings.

Our new standard design features a comfortable handle and snap-in/out protective cover that allows users to stow the business end of the tool to help protect from inadvertent personal injury when the tools are not in use.

Many different design types currently exist for our vast terminal product range, which we continue to convert. If you would like the tool you use converted to the new design, want a custom kit or tools in this design for other manufacturers products – contact us, and where volumes permit we will be pleased to provide you with a quotation for your requirement.



For more detailed information please visit our websites:

www.tooling.te.com • www.tooling.te.com/europe • www.tooling.te.com/china

FFC-FPC Equipment

FFC Hand Tool

The very easy-to-handle 10 position hand tool allows variable settings for both the foil stop and foil guide. A correct and repeatable crimp process is achieved by an integrated ratchet mechanism. A FFC hand tool case can be built up around your particular application requirements.

The tool allows crimp connections to be made between foil and 1 to 10 position MQS terminals. The crimp height is set for 70 mm thick foil.



FFC Termination Machine for Flexible Sensor Foil

The Termination Machine is an electrical driven semi-automatic assembly machine that uses different applicators to terminate reel-feed FFC contacts to manually supplied FFC cables. The machine terminates a predefined number of contacts to the supplied cable end.

TE Connectivity products FFC MQS, FFC AMPMODU .100, Junior Timer, AMPMODU .50 and soldered contacts are compatible.



- Quick-change of applicator
- Alignment of the cable is realized in the machine
- Interchangeable applicators available for different products
- Number of pins can be programmed (max. 38 mm with pitch 2.54 mm)
- Pitch 1.27 mm up to 5.08 mm can be programmed
- Individual wire positions can be skipped
- Operator friendly interface via touch screen
- Integrated crimp force monitoring by CQM (optional)

FFC Applicator

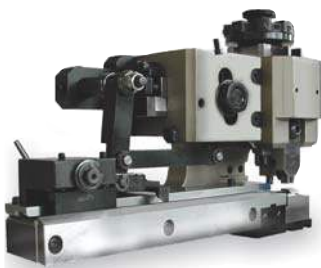

The FFC Applicator is designed for FFC and FPC terminations. It is normally delivered with a special TE Connectivity crimp machine, but is also compatible with standard presses (press stroke 40 mm), if a wire feed is supplied.

The adjustment of the crimp height is similar to other TE Connectivity crimp applicators. All wear parts are easy to change.

The FFC Applicator is available for different TE Connectivity contacts, such as:

- FFC MQS,
- FFC Junior Timer,
- FFC AMPMODU .100,
- FFC AMPMODU .050,
- FFC Card Edge,
- FFC ACTION PIN and
- FFC Soldering Pin.

For more detailed information please visit our websites:

www.tooling.te.com • www.tooling.te.com/europe • www.tooling.te.com/china

FFC-FPC Equipment

Assembly Machine to Connect FFC and PCB

This machine has been specially designed to connect a Flexible Printed Sensor with a PCB by using an ACTION PIN FFC Contact. The Flexible Printed Sensor and the PCB are manually loaded into the machine. After the cycle has been started, the insertion head is positioned above the first insertion position.

The pre-formed contact is cut off the carrier strip and gets simultaneously inserted into the PCB and crimped to the Flexible Printed Sensor.

Several contacts form the complete connection between the sensor and the PCB. The force, required to insert the ACTION PIN contact with the PCB, is monitored by a force sensor.

To accommodate two types of PCBs, the PCB holder is positioned by pneumatic cylinders. The desired position is selected via the operator interface.



FFC/FPC Machine

The FFC/FPC bench machine creates electrical connections between TE Connectivity FFC terminals and flexible flat cables. Thanks to its adaptable circuit fixture the machine is simple and easy to load.

Prior to initializing a crimp cycle, the vision system establishes the precise location of the first conductor track. A positional correction is effected as appropriate.

The equipment combines the functions of terminal feed, cutting the product off the carrier strip, crimping and chopping of the carrier strip. An integrated crimp force monitor ensures high quality crimp connections.

An optional faulty crimp cut-off device prevents the further use of defect circuits.



For more detailed information please visit our websites:

www.tooling.te.com • www.tooling.te.com/europe • www.tooling.te.com/china

Magnet Wire Equipment

MAG-MATE and SIAMEZE Inserter Mark II with PLC

TE Connectivity magnet wire terminations are a perfect connecting alternative to all soldering techniques used in a lead-free environment. Special knowledge is required to design a mass manufacturing line for insulation displacement crimps on thin lacquer insulated wires with high yield. Design aspects of the terminal, the cavity and the machine all need to be harmonized.

With the Inserter Mark II TE Connectivity can offer an economic solution especially

for the application of MAG-MATE and SIAMEZE terminals.



MAG-MATE Inserter Mark II with PLC and Insertion Force Control

This advanced insertion machine provides the features of the MAG-MATE Inserter Mark II with an additional force distance control system. The machine is designed to apply multiple different contacts and will be customized according to the customer or product specific requirement.

The contacts can be used as single contacts or in strip form (bridge function adjusted "on-the-fly"). A gauge is available to check the adjusted insertion force and to recalibrate the insertion force control sensor.



Pneumatic Insertion Tool for MAG-MATE Terminals

The pneumatic tool for MAG-MATE terminals features a rotary insertion finger to facilitate different insertion angles. This tool is designed for use in TE Connectivity

standard insertion machines such as P 200 and P 300 but can also be integrated into customized production lines or assembly cells.



For more detailed information please visit our websites:

www.tooling.te.com • www.tooling.te.com/europe • www.tooling.te.com/china

Magnet Wire Equipment

AMPLIVAR Terminator for Parallel and End Connections

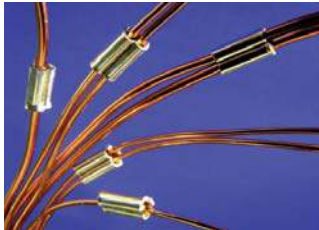

The machine was especially developed for processing magnet wire connections. Different versions for end-feed and side-feed contacts are available. The design takes into account that the motor windings and coils can be supplied directly to the connectors. The exposed crimp position permits precise handling. In case of end connections the projecting magnet wires are cut off. AMPLIVAR Splices and Terminals are specifically designed to terminate magnet wires or in combination with standard solid or stranded wire. In a one-step operation the magnet wire is automatically multiple ring stripped of its insulation as it is forced into the serrations during the precisely controlled crimping operation.

As many as three magnet wires can be terminated, simultaneously in one splice. Nearly the entire AMPLIVAR splice program can be applied with this machine in combination with suitable applicators.

The comprehensive range of manufacturing possibilities demands a specific machine and applicator combination.

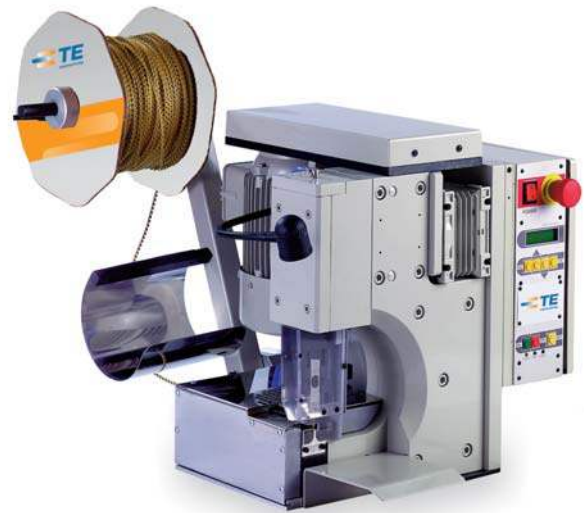

APT IIIA and APT IIE AMPLIVAR Product Terminators

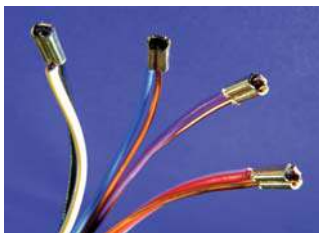

APT semi-automatic bench machines are available in two versions: the APT IIIA machine with automatic precision adjustment controlled by the Crimp Quality Monitor (CQM) and the APT IIE machine with manual precision adjustment. To apply a splice or contact, simply place the wires in the

target area and depress the foot switch. The machine automatically shears the splice or contact from the strip, crimps it, shears off excess wire, and advances the next splice or contact into position. With CQM, the APT IIIA machine assists in achieving 6-sigma processing capability.

For operations with multiple wire sizes, the APT IIIA machine provides programmable sequencing of different crimp-height settings, and it can store up to 2000 different programmes of 7 different settings each.



For more detailed information please visit our websites:

www.tooling.te.com • www.tooling.te.com/europe • www.tooling.te.com/china

Board Processing Equipment

Press-Fit Systems

TE Connectivity offers a complete line of manual and automatic servo-electric driven presses for the application of press-fit connectors. Each unit is PC controlled and incorporates force feedback through load cells. The servo-electric drive can precisely

control applied force, speed and travel without the “spring” effect common in pneumatic and hydraulic presses. Finally, force and SPC data for every connector pressed is stored and can be retrieved for 100% traceability of all boards produced.

This system minimizes costly scrap by assuring that the minimum force is reached, maximum force is not exceeded and the connector is gently seated to the required height.

**CSP 3T
Servo-Electric Press**

The SEP 3T is a servo-electric press to apply PCBs onto compliant pin connectors and housings. The system provides control and monitoring of the press cycle force, distance and speed to meet the quality and traceability essential in the safety and control applications where these components are typically used. Optional Pin Penetration Sensing (PPS) tooling can verify the correct penetration of every pin through the PCB.

PCBs are manually loaded onto the connector/housing and placed in specific support fixtures. When the press cycle

is initiated by the operator, the product is shuttled into the CSP 3T and pressed to the required force and/or height.

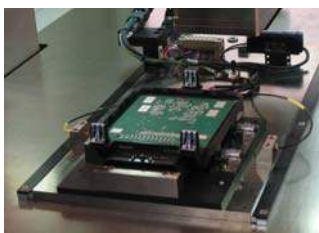

A key feature of the CSP press system is an automatic shuttle that positions the PCB and housing/connector stack up underneath the upper insertion tool.



For more detailed information please visit our websites:

www.tooling.te.com • www.tooling.te.com/europe • www.tooling.te.com/china

Board Processing Equipment

CBP-3T/5T
Bench Manual Electric Press

The benchtop press with midrange board handling and pressing capacities utilizes PC control and servo-electric drive system. Pressing capacities of 27 kN [3 tons] and 44 kN [5 tons] allow for a wide range of applications on boards up to 460 mm x 610 mm [18" x 24"]. These features and a compact footprint make this a powerful, versatile and portable press for PCB construction.



The run time screen provides complete operator interface and feedback.

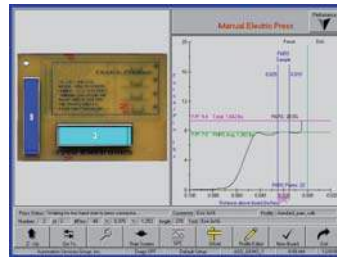

CMP 6T/CMP 12T
Manual Electric Press

A self-contained press on wheels that can easily be relocated almost anywhere on the production floor. The same PC controlled servo-electric drive system as the CBP units is used to provide a precise and repeatable pressing system to lower overall applied cost.

With up to 107 kN [12 tons] of pressing capacity and board handling up to 910 mm x 1220 mm [36" x 48"] on the CMP-12T machine, the

CMP press line is perfectly positioned to handle almost any press-fit application with midrange volumes.



For more detailed information please visit our websites:

www.tooling.te.com • www.tooling.te.com/europe • www.tooling.te.com/china

Board Processing Equipment

**CAP 6T
Automatic
Electric Press**

The CAP-6T Automatic Electric Press is the newest addition to the successful TE Connectivity servo press line. It provides the proven force control capabilities and quality assurance of the line in an automatic press. The automatic pressing capabilities of the CAP-6T Press provide the end user with greater control and simplified processing to help improve quality, lower rework and prevent rejects. This provides users with lower true applied cost and higher end profits. The CAP-6T Press was designed to apply compliant pin connectors to a wide range of PCBs. It is fully capable of handling the most demanding applications today from daughter cards to mid-planes to back-planes.



With board capacity up to 760 mm x 910 mm [30" x 36"] and a press force up to 53 kN [6 tons], the CAP-6T Press is focused at all but the

largest board applications. The CAP-6T Press can also hold up to 12 insertion tools and uses a lower support fixture.

**CSM 5T
Connector Seating
Machine**

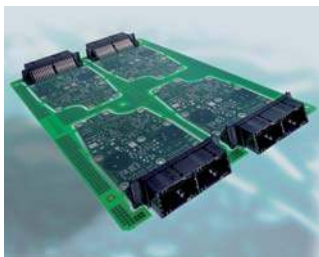

PCB and connectors are loaded manually into fixtures. When started, the machine checks the correct loading of the connectors before placing the connectors onto the PCB. The tool then moves under the press ram where the connectors get pressed one after the other onto the PCB. The CBP-5T servo-electric press is used to seat the PCB which provides a force-distance check to guarantee quality production.

A special tooling plate allows the sequential pressing of a number of different pre-loaded connectors. An intermediate plate, positioned between the PCB with its pre-positioned

connectors and the flat rock press ram contains the connector specific press tools. For each connector a force distance curve is available after completion.

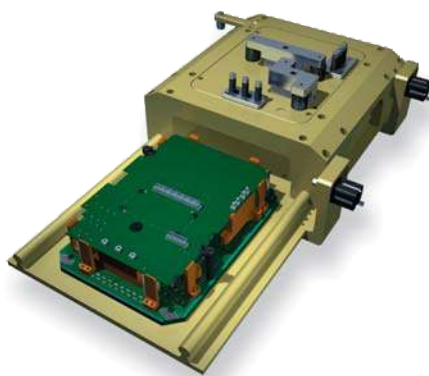

For more detailed information please visit our websites:

www.tooling.te.com • www.tooling.te.com/europe • www.tooling.te.com/china

Board Processing Equipment

PCB Depanelling Systems

TE Connectivity knows the total applied cost of your product is almost at its highest when the PCB is separated from the panel. Protect the time and investment that has been applied to your product by using a gentle, safe and effective depanelling equipment solutions offered by TE Connectivity.

TE Connectivity offers equipment solutions including the 2016AT Singulation Press, SmartRouter Singulation Machine, SAR-1000-B/D, SAR-1400-L Laser Depanelling and ILR-2000 Automatic In-Line Routing Machines.

All of our equipment solutions offer effective and safe depanelling for your products. Depanelling induced stress is simply unacceptable in today's competitive market.

GAS SAR-1000-B and SAR-1000-D Depanelling Machines



The GAS SAR-1000-B and SAR-1000-D depanelling systems for printed circuit boards and bare boards offers a largely automated process for depanelling by milling and/or sawing.



The GAS depanelling systems SAR-1000-B and SAR-1000-D offer the following outstanding features:

- Very fast and precise linear motor axes for all three directions of movements (X, Y and Z)
- Fast shuttle system with short changing time <4 seconds
- Large milling area
- Flexible milling brush holder – no additional down-holding device required
- Technics tool kit including
- Broken tool control
- Automatic and continuous bit control for different levels
- Tool diameter monitoring
- Production data processing system
- Depanelling speed with disc up to 20 m/min.

For more detailed information please visit our websites:

www.tooling.te.com • www.tooling.te.com/europe • www.tooling.te.com/china

Equipment for Electrical Testing

Electrical Test Equipment for the Automotive Industry

Specialized wire harness testing for the automotive subcontracting industry is based on high volume requirements and incorporates the automatic inspection of non-electrical parameters.

To this aim well thought out adaptation systems are the key factor providing a fast, reliable and user-friendly test environment. Test benches and adaptation systems from TSK Prüfsysteme

GmbH benefit from 25 years of experience in this market. TE Connectivity is the world-wide distribution partner of TSK and can provide a large variety of harness and functional test systems to it's customers.



TSK Cable Test and Function Test

Small stand alone cable testers like the CT30 at an attractive price level already offer the full range of electrical standard testing for up to 512 internal test points. In combination with the powerful CS WIN software even more complex test programs can be created by using programmable I/O's and applied statistical functions.

Larger harnesses will use one of the many different test system types which basically provide a standard grid to implement TSK's adaptation modules.

The function test systems are designed for more complex end-of-line tests on complete subassemblies, like cockpits, automotive doors, relay boxes and control units.



For more detailed information please visit our websites:
www.tooling.te.com • www.tooling.te.com/europe • www.tooling.te.com/china

Application Tooling Global Field Service Organization

TE Connectivity provides Global Field Service support on our application tooling. Field Specialists are located across every continent to provide timely response to customer needs.

In addition to installation, warranty and repair service, TE Connectivity Field Specialists can help you with equipment choices, training of maintenance and operation personnel, troubleshooting assistance and spare parts. Service contracts to cover all your application equipment needs are also available.

We have implemented a service management tool that provides standardization of reporting that gives us the ability to continuously improve our global service organization. Throughout the year we educate our field service engineers on the latest industry technologies and equipment.

See for yourselves the advantages of our professional consultation and individual services. Our qualified service teams are ready to assist you.

Service Offerings

Standard Service

Includes troubleshooting problems, making repairs, and/or installing parts.

Equipment Installations

Providing installation, set-up and training of application equipment at the time of delivery.

Training

Providing Customers with practical training programs addressing machine operation, set-up, maintenance, inspection, and connector application. Training programs can be scheduled at the Customer's site or at a TE Connectivity training center. A training certificate will be issued upon the completion of each formal training course.

We are proud to be able to offer a comprehensive range of customer training programs.

The following are some of the standard training programs we offer:

- The Fundamentals of Crimp Technology, 4901
- The Proper Handling of Crimping Applicators, 4902
- Crimping Training Program, 4903 (combination of 4901 and 4902)
- The Proper Handling of Crimping Hand Tools, 4904
- FFC Crimp Technology, 4906
- Fundamentals of Crimping Technology for Machine Operators, 4907
- Magnet Wire Connection Technology, 4910
- Advanced Seminar on Crimping Quality, 4911
- Advanced Seminar on Crimp Force Monitoring, 4912
- Advanced Cross Sectioning – Photos, 4913
- MAG-MATE Module, Pneumatic, 4914
- Insulation Displacement Technology, 4930

Service Contracts

Preventive Maintenance and/or Inspection Calibration

Provides service for periodic visits to perform Preventive Maintenance and/or Inspection Calibration Service on Hand Tools, Applicators, Bench and Automatic Equipment.

Comprehensive Service

Provides for a specified number of Field Specialist visits. A visit can be used for services such as standard service, installation, set-up and training for all application equipment, preventive maintenance and/or inspection calibration, spare parts management, equipment process evaluation and technical assistance on application tooling and/or product related problems or concerns.

“A customized service / training contract ensures equipment optimization”

Short Term Rental of Crimping Applicators

Applicators are being increasingly required at short notice for a limited period. This may include pre-production runs, prototype series, and the subsequent production of single part requirement or simply small series production. It is often uneconomical to purchase a crimp tool or to rent it on a long-term basis, when it is only required for a few weeks in the year. Our short-term rental service has applicators readily available for you, which you can return when complete with your rental period.

Your local TE Connectivity representative will gladly inform you about the availability of an appropriate applicator for your specific need.

For more detailed information please visit our websites:

www.tooling.te.com • www.tooling.te.com/europe • www.tooling.te.com/china

Application Tooling Americas Field Service Locations

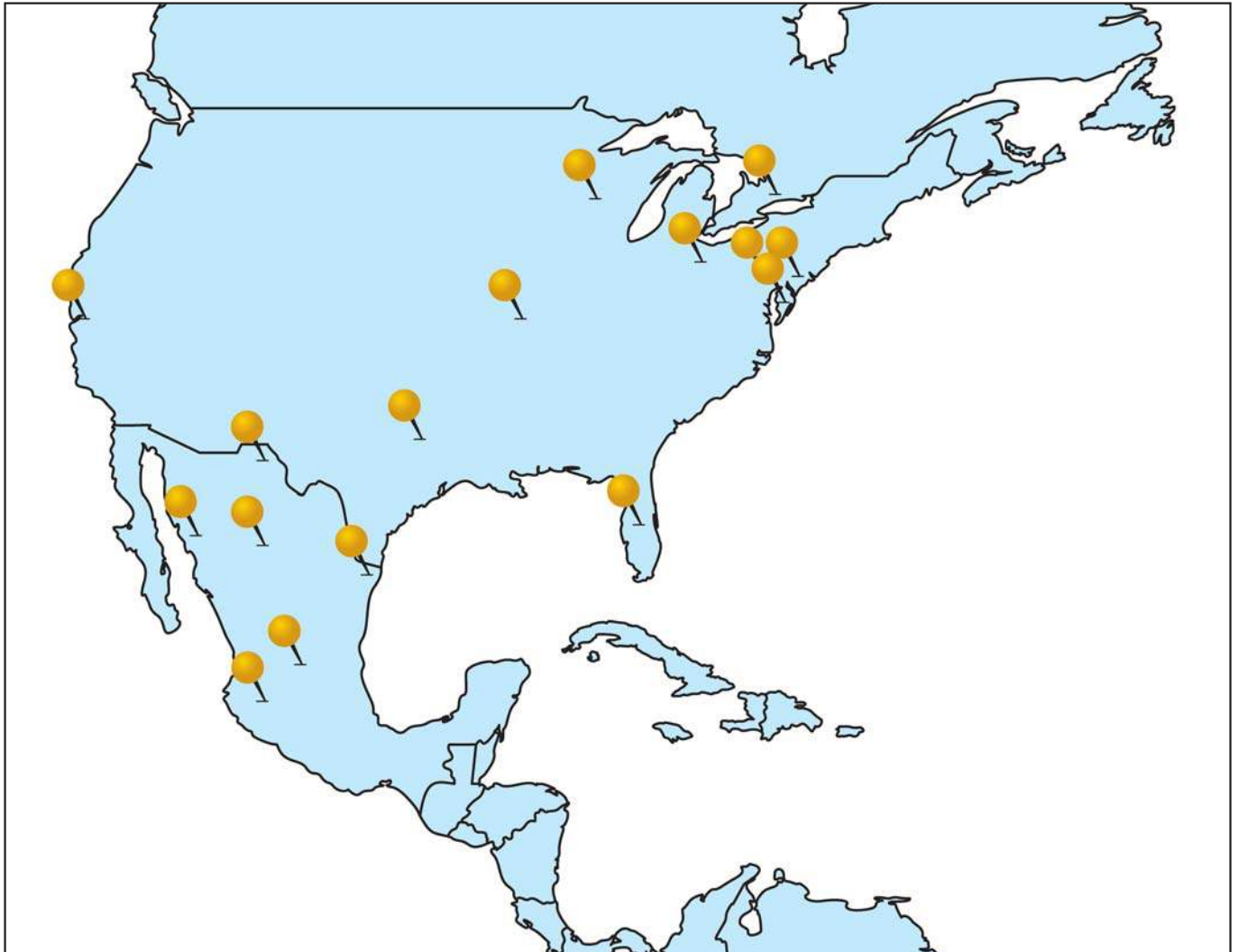

Americas Field Service Locations

- | | |
|----------------|-------------|
| Canada: | Mexico: |
| Toronto | Chihuahua |
| | Guadalajara |
| United States: | Hermosillo |
| California | Juarez |
| Florida | Reynosa |
| Minnesota | |
| Missouri | |
| New Jersey | |
| Ohio | |
| Pennsylvania | |
| Texas | |

AMERICAS FIELD SERVICE

1-800-722-1111

fieldservicesnorthamerica@te.com

For more detailed information please visit our websites:

www.tooling.te.com • www.tooling.te.com/europe • www.tooling.te.com/china

Application Tooling EMEA Field Service Locations

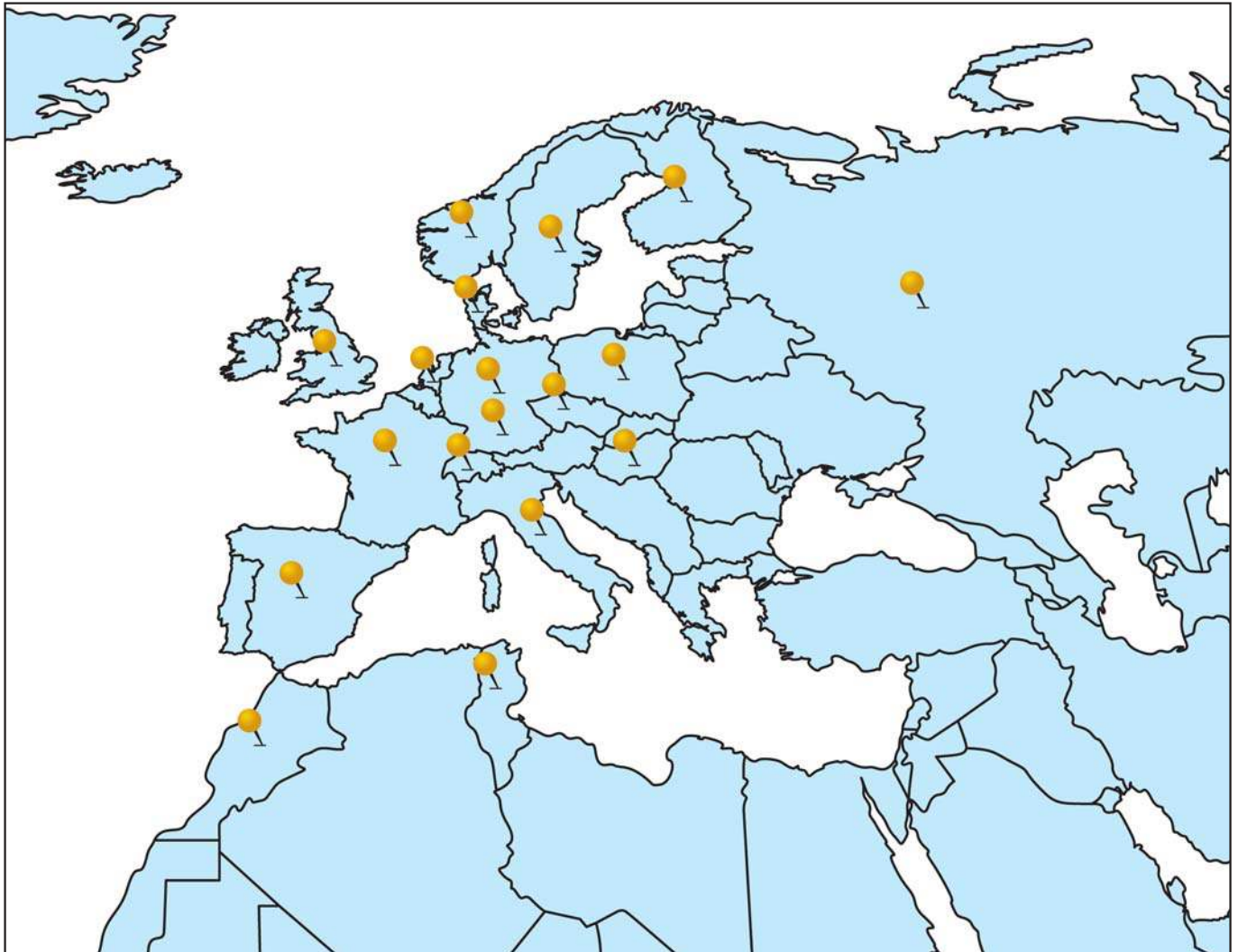

EMEA Field Service Locations

- | | |
|----------------|--------------|
| Austria | Netherlands |
| Czech Republic | Norway |
| Denmark | Poland |
| Finland | Russia |
| France | South Africa |
| Germany | Spain |
| Great Britain | Sweden |
| India | Switzerland |
| Italy | Tunisia |
| Morocco | |

EMEA FIELD SERVICE
+49 (0) 6251 133 1376
kd-hotline.ampde@te.com

For more detailed information please visit our websites:

www.tooling.te.com • www.tooling.te.com/europe • www.tooling.te.com/china

Application Tooling Asia Pacific Field Service Locations

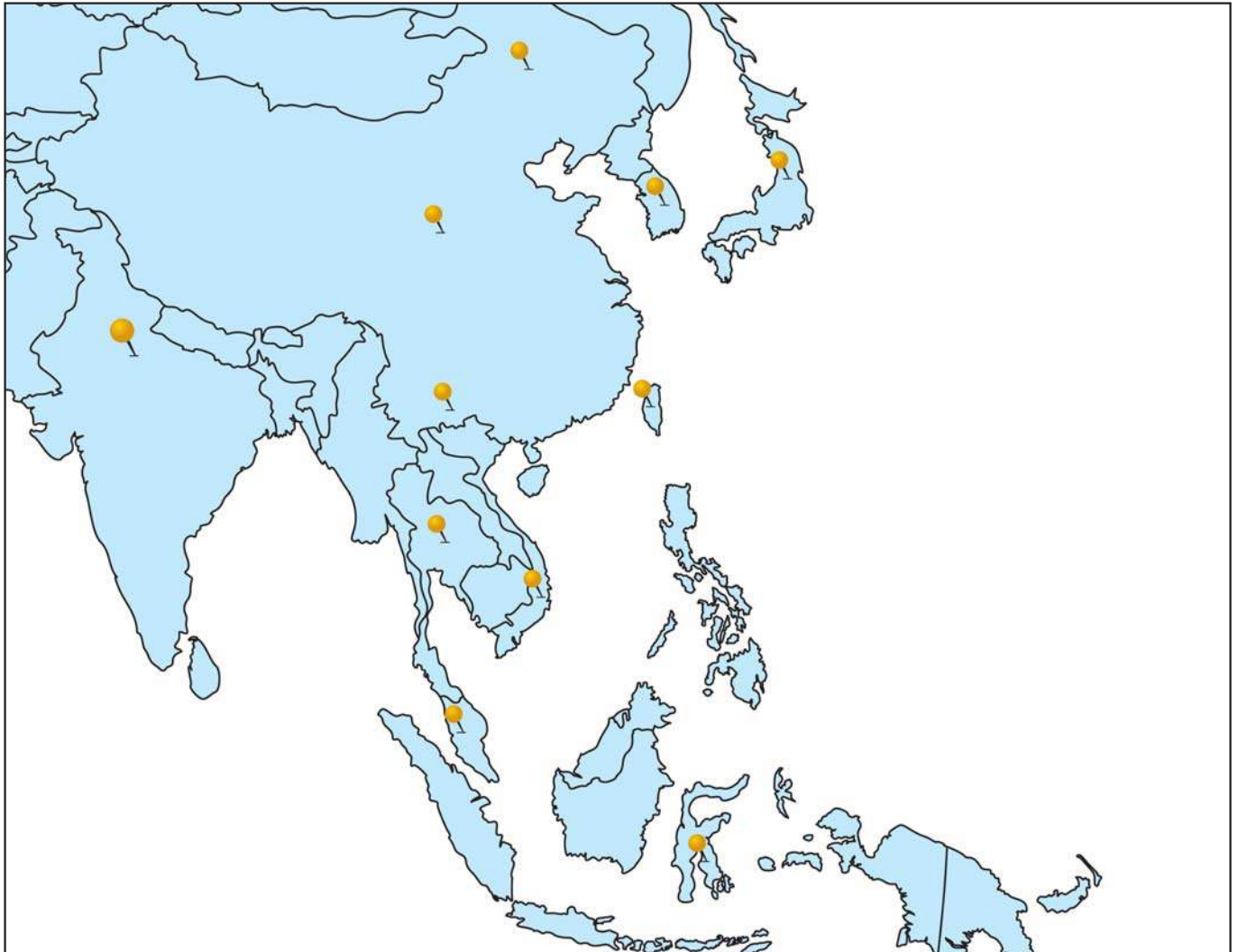

Asia Pacific Field Service Locations

- | | |
|-----------|-----------|
| Australia | Singapore |
| China | Taiwan |
| Japan | Thailand |
| Korea | Vietnam |

ASIA PACIFIC FIELD SERVICE
Please contact your local Sales or Service Engineer

For more detailed information please visit our websites:

www.tooling.te.com • www.tooling.te.com/europe • www.tooling.te.com/china

Numerical Index

Part Number	Page	Part Number	Page	Part Number	Page	Part Number	Page
100132-1	3-20	539960-1	3-7, 3-45,	1-962916-1	3-12	1-963741-1	3-18
284844-1	3-57, 3-69		3-46, 3-69,	1-962916-2	3-12	1-963741-2	3-18
284844-2	3-57, 3-69		3-70, 3-71	1-962916-3	3-12	2-963741-1	3-18
284844-3	3-57, 3-69	539971-1	3-44, 3-66,	2-962916-1	3-12	2-963741-2	3-18
284844-4	3-57, 3-69		3-67	2-962916-2	3-12	1-963742-1	3-18
284848-1	3-57, 3-69,	734532-1	3-25	2-962916-3	3-12	1-963742-2	3-18
	3-70	734533-1	3-25	1-962917-1	3-18	2-963742-1	3-18
284848-2	3-57, 3-69	734538-1	3-12	1-962917-2	3-18	2-963742-2	3-18
284848-3	3-57, 3-69	734688-1	3-18	2-962917-1	3-18	1-963743-1	3-18
284848-4	3-57, 3-69	828904-1	3-14	2-962917-2	3-18	1-963743-2	3-18
284853-1	3-32, 3-45	828904-2	3-14	1-962918-1	3-18	2-963743-1	3-18
284853-2	3-32, 3-45	828905-1	3-14	1-962918-2	3-18	2-963743-2	3-18
284853-3	3-32, 3-45	828922-1	3-14, 3-15	2-962918-1	3-18	1-963744-1	3-18
284853-4	3-32, 3-45	828922-2	3-15	2-962918-2	3-18	1-963744-2	3-18
284858-1	3-32, 3-45	828985-1	3-14	1-962919-1	3-18	2-963744-1	3-18
284858-2	3-32, 3-45	828986-1	3-14	1-962919-2	3-18	2-963744-2	3-18
284858-3	3-32, 3-45	929039-1	3-40, 3-60	2-962919-1	3-18	1-963745-1	3-12
284858-4	3-32, 3-45	929092-1	3-42	2-962919-2	3-18	1-963745-2	3-12
284875-1	3-33, 3-46	1-929150-1	3-24	963243-1	3-20	1-963745-3	3-12
284875-2	3-33, 3-46	1-929151-1	3-24	963244-1	3-20	2-963745-1	3-12
284875-3	3-33, 3-46	1-929151-2	3-24	963245-1	3-20	2-963745-2	3-12
284875-4	3-33, 3-46	1-929152-1	3-24	963292-1	3-15	2-963745-3	3-12
284879-1	3-33, 3-46	1-929153-1	3-24	963293-1	3-15	1-963746-1	3-12
284879-2	3-33, 3-46	953717-1	3-62	963294-1	3-15	1-963746-2	3-12
284879-3	3-33, 3-46	1-962841-1	3-12	963530-1	3-8	1-963746-3	3-12
284879-4	3-33, 3-46	1-962841-2	3-12	963531-1	3-8	2-963746-1	3-12
539623-1	3-18	1-962841-3	3-12	1-963734-1	3-18	2-963746-2	3-12
539635-1	3-11, 3-18	2-962841-1	3-12	1-963734-2	3-18	2-963746-3	3-12
539663-2	3-7	2-962841-2	3-12	2-963734-1	3-18	1-963748-1	3-12
539721-2	3-9, 3-10	2-962841-3	3-12	2-963734-2	3-18	1-963748-2	3-12
539722-2	3-9, 3-10	1-962842-1	3-12	1-963735-1	3-18	1-963748-3	3-12
539723-2	3-9, 3-10	1-962842-2	3-12	1-963735-2	3-18	2-963748-1	3-12
539725-2	3-9	1-962842-3	3-12	1-963736-1	3-18	2-963748-2	3-12
539726-2	3-9	2-962842-1	3-12	1-963736-2	3-18	2-963748-3	3-12
539727-2	3-9	2-962842-2	3-12	2-963736-1	3-18	1-963749-1	3-12
539759-2	3-18	2-962842-3	3-12	2-963736-2	3-18	1-963749-2	3-12
539783-1	3-23, 3-24	1-962845-1	3-18	1-963737-1	3-18	1-963749-3	3-12
539783-5	3-23, 3-24	1-962845-2	3-18	1-963737-2	3-18	2-963749-1	3-12
539783-6	3-23, 3-24	2-962845-1	3-18	2-963737-1	3-18	2-963749-2	3-12
539783-7	3-24	2-962845-2	3-18	2-963737-2	3-18	2-963749-3	3-12
539783-8	3-24	1-962846-1	3-18	1-963738-1	3-18	963764-1	3-25
539783-9	3-24	1-962846-2	3-18	1-963738-2	3-18	963764-2	3-25
1-539783-0	3-24	2-962846-1	3-18	1-963739-1	3-18	963765-1	3-25
539950-2	3-4, 3-5	2-962846-2	3-18	1-963739-2	3-18	963765-2	3-25
539951-2	3-11	1-962915-1	3-12	2-963739-1	3-18	963766-1	3-25
539952-2	3-11	1-962915-2	3-12	2-963739-2	3-18	963766-2	3-25
539953-2	3-17	1-962915-3	3-12	1-963740-1	3-18	963767-1	3-25
539954-2	3-17	2-962915-1	3-12	1-963740-2	3-18	963767-2	3-25
539955-2	3-17	2-962915-2	3-12	2-963740-1	3-18	963768-1	3-25
539956-2	3-17	2-962915-3	3-12	2-963740-2	3-18	963768-2	3-25

Numerical Index

Part Number	Page	Part Number	Page	Part Number	Page	Part Number	Page
963769-1	3-25	964265-2	3-7	964307-1	3-19	4-967627-1	3-39, 3-49
963769-2	3-25	964265-3	3-7	964308-1	3-19	1-967628-1	3-39, 3-49
963770-1	3-25	964266-2	3-7	964309-1	3-19	2-967628-1	3-39, 3-49
963770-2	3-25	964266-3	3-7	964310-1	3-19	3-967628-1	3-39, 3-49
963771-1	3-25	964267-1	3-7	964311-1	3-19	4-967628-1	3-39, 3-49
963771-2	3-25	964267-2	3-7	964312-1	3-19	1-967629-1	3-39, 3-49
963772-1	3-25	964267-3	3-7	964313-1	3-19	1-967630-1	3-39, 3-49
963772-2	3-25	964268-1	3-7	964314-1	3-19	2-967630-1	3-39, 3-49
963773-1	3-25	964268-2	3-7	964971-1	3-8	3-967630-1	3-39, 3-49
963773-2	3-25	964268-3	3-7	964972-1	3-8	967631-1	3-49
963774-1	3-25	964269-2	3-7	1-965641-1	3-39, 3-49	967632-1	3-49
963774-2	3-25	964269-3	3-7	2-965641-1	3-39, 3-49	967633-1	3-49
963775-1	3-25	964270-2	3-7	3-965641-1	3-39, 3-49	967634-1	3-49
963775-2	3-25	964270-3	3-7	4-965641-1	3-39, 3-49	967635-1	3-49
1-963860-1	3-12	1-964291-3	3-13	1-965982-1	3-12	967652-1	3-21
1-963860-2	3-12	2-964291-1	3-13	1-965982-3	3-12	1-968050-1	3-18
1-963860-3	3-12	1-964292-3	3-13	1-965983-1	3-12	2-968050-1	3-18
2-963860-1	3-12	2-964292-1	3-13	1-965983-3	3-12	1-968051-1	3-18
2-963860-2	3-12	1-964293-3	3-13	1-965984-1	3-18	2-968051-1	3-18
2-963860-3	3-12	2-964293-1	3-13	2-965984-1	3-18	968271-1	3-49
1-963861-1	3-12	2-964293-2	3-13	1-965985-1	3-18	1-968849-1	3-9
1-963861-2	3-12	1-964294-3	3-13	2-965985-1	3-18	1-968849-2	3-9
1-963861-3	3-12	2-964294-1	3-13	966140-1	3-39, 3-55	1-968849-3	3-9
2-963861-1	3-12	2-964294-2	3-13	966140-2	3-39, 3-55	1-968851-1	3-9
2-963861-2	3-12	1-964295-3	3-13	966140-3	3-39, 3-55	1-968851-2	3-9
2-963861-3	3-12	2-964295-1	3-13	966140-4	3-39, 3-55	1-968851-3	3-9
963898-1	3-6	2-964295-2	3-13	966140-5	3-39, 3-55	1-968853-1	3-9
963898-2	3-6	1-964296-3	3-13	966140-6	3-39, 3-55	1-968853-3	3-9
963898-3	3-6	2-964296-1	3-13	9-966140-1	3-55	1-968855-1	3-9
963899-1	3-6	2-964296-2	3-13	9-966140-2	3-55	1-968855-2	3-9
963899-2	3-6	1-964297-3	3-13	9-966140-3	3-55	1-968855-3	3-9
963899-3	3-6	2-964297-1	3-13	9-966140-4	3-55	1-968857-1	3-9
963900-1	3-6	1-964298-3	3-13	9-966140-5	3-55	1-968857-3	3-9
963900-2	3-6	2-964298-1	3-13	9-966140-6	3-55	1-968859-1	3-9
963900-3	3-6	1-964299-3	3-13	1-966867-1	3-59, 3-72	1-968859-3	3-9
963901-1	3-6	2-964299-1	3-13	1-966867-2	3-59, 3-72	1-968872-1	3-9
963901-2	3-6	4-964299-1	3-13	967116-1	3-56	1-968872-2	3-9
963901-3	3-6	1-964300-3	3-13	967116-2	3-56	1-968872-3	3-9
963902-1	3-6	2-964300-1	3-13	1-967588-1	3-24	1-968873-1	3-9
963902-2	3-6	4-964300-1	3-13	1-967589-1	3-24	1-968873-2	3-9
963902-3	3-6	1-964301-3	3-13	1-967589-2	3-24	1-968873-3	3-9
963903-1	3-6	2-964301-1	3-13	1-967590-1	3-24	1-968874-1	3-9
963903-2	3-6	1-964302-3	3-13	1-967591-1	3-24	1-968874-3	3-9
963903-3	3-6	2-964302-1	3-13	1-967626-1	3-39, 3-49	1-968875-1	3-9
963904-1	3-6	964303-1	3-19	2-967626-1	3-39, 3-49	1-968875-2	3-9
963904-2	3-6	964304-1	3-19	3-967626-1	3-39, 3-49	1-968875-3	3-9
963904-3	3-6	964305-1	3-19	4-967626-1	3-39, 3-49	1-968876-1	3-9
963905-1	3-6	964305-3	3-19	1-967627-1	3-39, 3-49	1-968876-3	3-9
963905-2	3-6	964306-1	3-19	2-967627-1	3-39, 3-49	1-968877-1	3-9
963905-3	3-6	964306-3	3-19	3-967627-1	3-39, 3-49	1-968877-3	3-9

Numerical Index

Part Number	Page	Part Number	Page	Part Number	Page	Part Number	Page
1-968880-1	3-9	8-968972-1	3-39, 3-49, 3-55	1241377-1	3-4	1241397-2	3-11
1-968880-3	3-9			1241377-2	3-4	1241397-3	3-11
1-968882-1	3-9	5-968973-1	3-39, 3-49, 3-55	1241378-1	3-4	1241400-1	3-17
1-968882-3	3-9			1241378-2	3-4	1241401-1	3-17
1-968895-1	3-9	6-968973-1	3-39, 3-49, 3-55	1241378-3	3-4	1241402-1	3-17
1-968895-3	3-9			1241379-1	3-4	1241402-3	3-17
1-968896-1	3-9	7-968973-1	3-39, 3-49, 3-55	1241379-2	3-4	1241403-1	3-17
1-968896-3	3-9			1241379-3	3-4	1241403-3	3-17
1-968946-1	3-12	8-968973-1	3-39, 3-49, 3-55	1241380-1	3-4	1241404-1	3-17
1-968946-2	3-12			1241380-2	3-4	1241404-3	3-17
2-968946-1	3-12	5-968974-1	3-39, 3-49	1241380-3	3-4	1241405-1	3-17
2-968946-2	3-12	6-968974-1	3-39, 3-49, 3-55	1-1241380-2	3-4	1241405-3	3-17
3-968946-1	3-12			1241381-1	3-4	1241406-1	3-17
1-968947-1	3-12	7-968974-1	3-39, 3-49, 3-55	1241381-2	3-4	1241406-3	3-17
1-968947-2	3-12			1241381-3	3-4	1241407-1	3-17
2-968947-1	3-12	8-968974-1	3-39, 3-49, 3-55	1-1241381-2	3-4	1241407-3	3-17
2-968947-2	3-12			1241386-1	3-11	1241408-1	3-17
3-968947-1	3-12	6-968975-1	3-39, 3-49, 3-50, 3-55	1241386-2	3-11	1241409-1	3-17
1-968965-1	3-12			1241386-3	3-11	1241410-1	3-17
1-968965-2	3-12	7-968975-1	3-39, 3-49, 3-50, 3-55	1241387-1	3-11	1241411-1	3-17
2-968965-1	3-12			1241387-2	3-11	1241412-1	3-17
2-968965-2	3-12	8-968975-1	3-39, 3-49, 3-50, 3-51, 3-55	1241387-3	3-11	1241412-3	3-17
3-968965-1	3-12			1241388-1	3-11	1241413-1	3-17
1-968966-1	3-12			1241388-2	3-11	1241413-3	3-17
1-968966-2	3-12	1-968976-9	3-39, 3-49	1241388-3	3-11	1241414-1	3-17
2-968966-1	3-12	2-968976-9	3-39, 3-49	1241389-1	3-11	1241414-3	3-17
2-968966-2	3-12	3-968976-9	3-39, 3-49	1241389-2	3-11	1241415-1	3-17
3-968966-1	3-12	1-968977-9	3-39, 3-49	1241389-3	3-11	1241415-3	3-17
5-968970-1	3-39, 3-49, 3-55	2-968977-9	3-39, 3-49	1241390-1	3-11	1241416-1	3-17
		3-968977-9	3-39, 3-49	1241390-2	3-11	1241416-3	3-17
6-968970-1	3-39, 3-49, 3-55	969007-1	3-19	1241390-3	3-11	1241417-1	3-17
		969008-1	3-19	1241391-1	3-11	1241417-3	3-17
7-968970-1	3-39, 3-49, 3-55	969028-2	3-7	1241391-2	3-11	1241418-4	3-17
		969028-3	3-7	1241391-3	3-11	1241419-4	3-17
8-968970-1	3-39, 3-49, 3-55	969029-2	3-7	1241392-1	3-11	1241846-1	3-7
		969029-3	3-7	1241392-2	3-11	1241846-2	3-7
5-968971-1	3-39, 3-49, 3-55	969079-2	3-7	1241392-3	3-11	1241846-3	3-7
		969079-3	3-7	1241393-1	3-11	1241847-1	3-7
6-968971-1	3-39, 3-49, 3-55	969080-2	3-7	1241393-2	3-11	1241847-2	3-7
		969080-3	3-7	1241393-3	3-11	1241847-3	3-7
7-968971-1	3-39, 3-49, 3-55	1241372-1	3-4	1241394-1	3-11	1-1241930-1	3-24
		1241372-2	3-4	1241394-2	3-11	1-1241930-2	3-24
8-968971-1	3-39, 3-49, 3-55	1241373-1	3-4	1241394-3	3-11	1326455-1	3-76, 3-78
		1241373-2	3-4	1241395-1	3-11	1326459-1	3-80
5-968972-1	3-39, 3-49, 3-55	1241374-1	3-4	1241395-2	3-11	1326460-1	3-77, 3-79
		1241374-2	3-4	1241395-3	3-11	1326464-1	3-80
6-968972-1	3-39, 3-49, 3-55	1241375-1	3-4	1241396-1	3-11	1326743-1	3-76, 3-78
		1241375-2	3-4	1241396-2	3-11	1326744-1	3-77, 3-79
7-968972-1	3-39, 3-49, 3-55	1241376-1	3-4	1241396-3	3-11	1-1355200-1	3-59, 3-72
		1241376-2	3-4	1241397-1	3-11	2-1355200-1	3-59, 3-72

Numerical Index

Part Number	Page	Part Number	Page	Part Number	Page	Part Number	Page
2-1355200-2	3-59	1418884-3	3-4	1564984-1	3-11	1703806-1	3-95, 3-96
1355289-1	3-44, 3-52	1418885-1	3-4	1564984-2	3-11	1703997-1	3-93
1355289-2	3-44, 3-52	1418885-3	3-4	1564984-3	3-11	1703998-1	3-93, 3-104
1355289-3	3-44, 3-52	1418994-1	3-41	1564985-1	3-11	3-1703998-1	3-93
1355289-4	3-44, 3-52	1-1452228-9	3-93, 3-104	1564985-2	3-11	4-1703998-1	3-93
1355290-1	3-44, 3-52	1534046-1	3-28, 3-29, 3-53	1564985-3	3-11	5-1703998-1	3-93
1355328-1	3-67, 3-74	1-1534126-1	3-84, 3-95	5-1579001-3	3-4, 3-5	1718149-1	3-65
1355437-1	3-26	2-1534126-1	3-84, 3-95	1579007-1	3-32, 3-33, 3-42, 3-57, 3-58, 3-59, 3-84, 3-85, 3-86, 3-87, 3-88, 3-90, 3-91, 3-92	1718149-2	3-65
1355437-2	3-26	3-1534126-1	3-84, 3-95	1-1579007-1	3-4, 3-5, 3-32, 3-33, 3-47, 3-48, 3-57, 3-58, 3-85, 3-87, 3-88, 3-89, 3-90, 3-93, 3-96, 3-98, 3-99	1718155-1	3-65
1355437-3	3-26	1-1534127-1	3-86, 3-97, 3-101	1-1579007-2	3-9, 3-11, 3-47, 3-48	1718156-1	3-64
1-1355833-1	3-10	2-1534127-1	3-86, 3-97	1-1579007-3	3-17, 3-43, 3-87, 3-88, 3-92, 3-98	1718156-2	3-64
1-1355849-1	3-23	3-1534127-1	3-86, 3-97	1-1579007-6	3-12, 3-13, 3-18, 3-19, 3-45, 3-46, 3-69, 3-70, 3-71, 3-95, 3-96, 3-97, 3-98, 3-99, 3-100	5-1718321-3	3-91, 3-100, 3-102
1-1355876-1	3-10	4-1534127-1	3-86, 3-97	1-1579007-7	3-25, 3-52, 3-73, 3-74	6-1718321-3	3-91, 3-100
1-1355877-1	3-10	1534160-1	3-5	4-1579016-0	3-4	5-1718323-1	3-91, 3-100
1-1355880-1	3-10	1534161-1	3-5	4-1579016-1	3-11	6-1718323-1	3-91, 3-100
1394026-1	3-67, 3-74	1534162-1	3-5	3-1579021-7	3-17	1-1718324-1	3-90, 3-99
1394026-2	3-67, 3-74	1534163-1	3-5	1-1670876-1	3-40	2-1718324-1	3-90, 3-99
9-1394049-1	3-84, 3-95	1534180-1	3-28, 3-30	1-1670877-1	3-40	3-1718324-1	3-90, 3-99
9-1394050-1	3-86	1534180-2	3-28, 3-30	2-1670879-1	3-40	1718328-1	3-99, 3-100
1-1394052-1	3-97, 3-101	1534181-1	3-28, 3-29	1703278-2	3-7	1718329-1	3-99, 3-100
1394132-1	3-8	1534184-1	3-28, 3-30	1703278-5	3-7	1-1718484-1	3-35, 3-36, 3-38, 3-47, 3-48
1394133-1	3-8	1534184-2	3-28, 3-30	1703279-2	3-7	1-1718484-2	3-35, 3-36, 3-38, 3-47, 3-48
1394511-1	3-21	1534188-1	3-51	1703279-5	3-7	1-1718484-3	3-35, 3-36, 3-38, 3-47, 3-48
1394512-1	3-21	1534238-1	3-62, 3-86, 3-101	1703279-5	3-7	1-1718484-4	3-35, 3-36, 3-38, 3-47
1-1394765-1	3-50	1534334-1	3-4	1703279-5	3-7	1-1718485-1	3-34, 3-35, 3-37
2-1394765-1	3-50	1534335-1	3-4	1703279-5	3-7	1-1718485-2	3-34, 3-35, 3-37
2-1394766-1	3-50	1534399-1	3-29, 3-31	1703799-1	3-84, 3-95	1-1718485-3	3-34, 3-35, 3-37
3-1394766-1	3-50	1534404-1	3-43	1703804-1	3-95, 3-96	1-1718485-4	3-34, 3-35, 3-37
3-1394766-2	3-50	1534404-2	3-43			1718488-1	3-36, 3-38, 3-47
1-1418362-1	3-90, 3-103	1534531-1	3-30, 3-31, 3-54			1718489-1	3-35, 3-37, 3-38, 3-47, 3-48
1-1418362-3	3-90, 3-103	1534579-1	3-30, 3-31			1718490-1	3-34, 3-37, 3-48
2-1418362-1	3-90, 3-103	1-1564297-6	3-92			1718490-2	3-34, 3-37, 3-48
2-1418362-3	3-90, 3-103	1564324-1	3-4				
5-1418363-1	3-91, 3-102	1564324-2	3-4				
5-1418363-3	3-91, 3-102	1564325-1	3-4				
1418408-1	3-5	1564325-2	3-4				
1418409-1	3-5	1564980-1	3-4				
1418410-1	3-5	1564980-2	3-4				
1418411-1	3-5	1564981-1	3-4				
1418882-1	3-90, 3-91, 3-92, 3-99, 3-100	1564981-2	3-4				
1-1418883-1	3-90, 3-99, 3-103	1564982-1	3-11				
2-1418883-1	3-90, 3-99, 3-103	1564982-2	3-11				
3-1418883-1	3-90, 3-99, 3-103	1564982-3	3-11				
4-1418883-1	3-90, 3-99	1564983-1	3-11				
1418884-1	3-4	1564983-2	3-11				
		1564983-3	3-11				

Numerical Index

Part Number	Page	Part Number	Page	Part Number	Page
1718558-1	3-5	1801286-6	3-62	2063536-1	3-19
1718559-1	3-5	1801326-1	3-63	2063560-1	3-19
1-1718626-1	3-60	1801326-3	3-63	1-2112035-1	3-88, 3-98
1-1718627-1	3-60	1801326-4	3-63	1-2112041-1	3-88, 3-98
1-1718628-1	3-60	1801326-5	3-63	1-2112041-2	3-88, 3-98
1-1718629-1	3-60	1801326-6	3-63	2112045-1	3-98
1718705-1	3-8	1813123-1	3-99, 3-100	2112046-1	3-88, 3-98
1719043-1	3-21	1813123-2	3-99, 3-100	1-2112162-1	3-86, 3-97
1-1719385-1	3-24	1-1823402-1	3-87	2112166-1	3-97
1-1719386-1	3-24	2-1823402-1	3-87	2112167-1	3-97
3-1719844-1	3-40	3-1823402-1	3-87	1-2112231-1	3-89
7-1719844-1	3-40	1-1823440-3	3-85, 3-96	2112233-1	3-89
8-1719844-1	3-40	2-1823440-3	3-85, 3-96	2112323-1	3-8
1743793-1	3-66, 3-73	3-1823440-3	3-85, 3-96	2112452-1	3-85
1743797-1	3-66, 3-73	4-1823440-3	3-85, 3-96	1-2112890-1	3-38, 3-47
1745043-1	3-58, 3-71	1-1823449-1	3-85, 3-96	1-2112890-2	3-38, 3-47
1745043-2	3-58, 3-71	1-1823498-1	3-90, 3-103	1-2112890-3	3-38, 3-47
1745043-3	3-58, 3-71	2-1823498-1	3-90, 3-103	1-2112890-4	3-38, 3-47
1745043-4	3-58, 3-71	3-1823498-1	3-90	1-2112891-1	3-37, 3-48
1745044-1	3-58, 3-71	4-1823498-1	3-90	1-2112891-2	3-37, 3-48
1745044-2	3-58, 3-71	1823500-1	3-90	1-2112891-3	3-37, 3-48
1745045-1	3-57, 3-70	2063265-1	3-6	1-2112891-4	3-37, 3-48
1745078-1	3-61	2063409-1	3-7	2-2112965-2	3-18
1745078-2	3-61	2063435-1	3-13	2-2112966-2	3-18
1801286-1	3-62	2063490-1	3-12	2138002-1	3-99, 3-100
1801286-3	3-62	2063533-1	3-13	2141345-1	3-93

Disclaimer and Trademarks

Disclaimer

While TE Connectivity (TE) has made every reasonable effort to ensure the accuracy of the information in this catalog, TE does not guarantee that it is error-free, nor does TE make any other representation, warranty or guarantee that the information is accurate, correct, reliable or current. TE reserves the right to make any adjustments to the information contained herein at any time without notice. TE expressly disclaims all implied warranties regarding the information contained herein, including, but not limited to, any implied warranties of merchantability or fitness for a particular purpose. The dimensions in this catalog are for reference purposes only and are subject to change without notice. Specifications are subject to change without notice. Consult TE for the latest dimensions and design specifications.

www.te.com
www.te.com/automotive
www.te.com/automotive/sensors
www.te.com/automotive/most

ACTION PIN, AMP 3K/40 and AMP 5K/40, AMP, AMP DUOPLUG, AMPLIVAR, AMP MCP, AMPMODU, AMP MONO-SHAPE, CERTI-CRIMP, ERGOCRIMP, LEAVYSEAL, MAG-MATE, MQS, NETCONNECT, PRO-CRIMPER, SIAMEZE, TE (logo), TE Connectivity and TE connectivity (logo) are trademarks.

iButton is a trademark of Maxim Integrated Products, Inc.
MOST is a trademark of SMSC Europe GmbH.
Teflon is a trademark of E.I. DuPont de Nemours and Co.
TopWin is a trademark of Komax AG.

Other product names, logos, and company names mentioned herein may be trademarks of their respective owners.

Engineering Notes

A large grid area for engineering notes, consisting of a uniform grid of small squares covering the majority of the page.

Engineering Notes

A large grid area for engineering notes, consisting of a uniform grid of small squares. The grid is empty and occupies the majority of the page's vertical space.

Engineering Notes

A large grid area for engineering notes, consisting of a uniform grid of small squares covering the majority of the page.

Engineering Notes

A large grid of graph paper for engineering notes, consisting of a 30x40 grid of small squares. The grid is empty and occupies the majority of the page.

Americas

Argentina – Buenos Aires
Phone: +54-11-4733-2202
Fax: +54-11-4733-2250

Brasil – São Paulo
Phone: +55-11-2103-6105
Fax: +55-11-2103-6204

Chile – Santiago
Phone: +56-2-345-0300
Fax: +56-2-223-1477

Canada – Toronto
Phone: +1-905-475-6222
Fax: +1-905-474-5520
Product Information Center:
Phone: +1-905-470-4425
Fax: +1-905-474-5525

Colombia – Bogotá
(Venezuela/Ecuador)
Phone: +57-1-319-8999
Fax: +57-1-319-8989

Mexico – Mexico City
Phone: +52-55-1106-0800
+01-800-733-8926
Fax: +52-55-1106-0910

**For Latin/South American
Countries not shown**
Phone: +54-11-4733-2015
Fax: +54-11-4733-2083

United States
Harrisburg, PA
Phone: +1-717-564-0100
Fax: +1-717-986-7575
Product Information Center:
Phone: +1-800-522-6752
Fax: +1-717-986-7575

Asia/Pacific

Australia – Sydney
Phone: +61-2-9554-2600
Fax: +61-2-9502-2556
Product Information Center:
Phone: +61-2-9840-8200
Fax: +61-2-9634-6188

Indonesia – Jakarta
Phone: +65-6482-0311
Fax: +65-6482-1012

Japan – Kawasaki, Kanagawa
Phone: +81-44-844-8111
Fax: +81-44-812-3207

Korea – Seoul
Phone: +82-2-3415-4500
Fax: +82-2-3486-3810

Malaysia – Kuala Lumpur
Phone: +60-3-7805-3055
Fax: +60-3-7805-3066

New Zealand – Auckland
Phone: +64-9-634-4580
Fax: +64-9-634-4586

Philippines – Makati City
Phone: +632-848-0171
Fax: +632-867-8661

People's Republic of China
Hong Kong
Phone: +852-2738-8731
Fax: +852-2735-0243

Shanghai
Phone: +86-21-2407-1588
Fax: +86-21-2407-1599

Singapore – Singapore
Phone: +65-6482-0311
Fax: +65-6482-1012

Taiwan – Taipei
Phone: +886-2-8768-2788
Fax: +886-2-8768-2268

Thailand – Bangkok
Phone: +66-2-955-0500
Fax: +66-2-955-0505

Vietnam – Ho Chi Minh City
Phone: +84-8-930-5546
Fax: +84-8-930-3443

Europe/Middle East/Africa

Austria – Vienna
Phone: +43-1-905-60-0
Fax: +43-1-905-60-1333
Product Information Center:
Phone: +43-1-905-60-1228
Fax: +43-1-905-60-1333

Belarus – Minsk
Phone: +375-17-237-47-94
Fax: +375-17-237-47-94
Product Information Center:
Phone: +7-495-790-7902
Fax: +7-495-721-1893

Belgium – Kessel-Lo
Phone: +31-73-6246-246
Fax: +31-73-6212-365
Product Information Center:
Phone: +31-73-6246-999
Fax: +31-73-6246-998

Bulgaria – Sofia
Phone: +359-2-971-2152
Fax: +359-2-971-2153

Czech Republic and Slovakia
Czech Republic – Kurim
Phone: +420-541-162-108
Fax: +420-541-162-104
Product Information Center:
Phone: +420-541-162-113
Fax: +420-541-162-104

Denmark – Glostrup
Phone: +45-43-48-04-00
Fax: +46-8-50-72-50-01
Product Information Center:
Phone: +46-8-50-72-50-20
Fax: +46-8-50-72-52-20

Egypt – Cairo
Phone: +20-2417-7647
Fax: +20-2419-2334

Estonia – Tartu
Phone: +372-5138-274
Fax: +372-7400-779

Finland – Helsinki
Phone: +358-95-12-34-20
Fax: +46-8-50-72-50-01
Product Information Center:
Phone: +46-8-50-72-50-20
Fax: +46-8-50-72-52-20

France – Cergy-Pontoise Cedex
Phone: +33-1-3420-8888
Fax: +33-1-3420-8800
Product Information Center:
Phone: +33-1-3420-8686
Fax: +33-1-3420-8623

France Export Divisions –
Cergy-Pontoise Cedex
Phone: +33-1-3420-8866
Fax: +33-1-3420-8300

Germany – Bensheim
Phone: +49-6251-133-0
Fax: +49-6251-133-1600
Product Information Center:
Phone: +49-6251-133-1999
Fax: +49-6251-133-1988

Greece – Athens
Phone: +30-210-9370-396/397
Fax: +30-210-9370-655

Hungary – Budapest
Phone: +36-1-289-1000
Fax: +36-1-289-1010
Product Information Center:
Phone: +36-1-289-1016
Fax: +36-1-289-1017

India – Bangalore
Phone: +91-80-2854-0800
Fax: +91-80-2854-0814

Italy – Collegno (Torino)
Phone: +39-011-4012-111
Fax: +39-011-4031-116
Product Information Center:
Phone: +39-011-4012-632
Fax: +39-011-4028-7632

Lithuania and Latvia
Lithuania – Vilnius
Phone: +370-5-213-1402
Fax: +370-5-213-1403

Netherlands – 's-Hertogenbosch
Phone: +31-73-6246-246
Fax: +31-73-6212-365
Product Information Center:
Phone: +31-73-6246-999
Fax: +31-73-6246-998

Norway – Nesbru
Phone: +47-66-77-88-50
Fax: +46-8-50-72-50-01
Product Information Center:
Phone: +46-8-50-72-50-20
Fax: +46-8-50-72-52-20

Poland – Warsaw
Phone: +48-22-4576-700
Fax: +48-22-4576-720
Product Information Center:
Phone: +48-22-4576-704
Fax: +48-22-4576-720

Romania – Bucharest
Phone: +40-21-311-3479/3596
Fax: +40-21-312-0574

Russia – Moscow
Phone: +7-495-790-7902
Fax: +7-495-721-1893
Product Information Center:
Phone: +7-495-790-7902
Fax: +7-495-721-1893

Russia – Yekaterinburg
Phone: +7-343-2531-153
Fax: +7-343-2531-152

Russia – Nizhniy Novgorod
Phone: +7-831-220-33-05/-06
Fax: +7-831-220-33-39/-40

Slovenia – Ljubljana
Phone: +386-1561-3270
Fax: +386-1561-3240

South Africa – Port Elizabeth
Phone: +27-41-503-4500
Fax: +27-41-581-0440

Spain – Barcelona
Phone: +34-93-291-0330
Fax: +34-93-201-7879
Product Information Center:
Phone: +34-93-291-0366
Fax: +34-93-209-1030

Sweden – Upplands Väsby
(Switchboard)
Phone: +46-8-50-72-50-00
Fax: +46-8-50-72-50-01
Product Information Center:
Phone: +46-8-50-72-50-20
Fax: +46-8-50-72-52-20

Switzerland – Steinach
Phone: +41-71-447-0447
Fax: +41-71-447-0444
Product Information Center:
Phone: +41-71-447-0447
Fax: +41-71-447-0400

Turkey – Istanbul
Phone: +90-212-281-8181/2/3
+90-212-282-5130/5430
Fax: +90-212-281-8184

Ukraine – Kiev
Phone: +380-44-206-2265
Fax: +380-44-206-2264
Product Information Center:
Phone: +380-44-206-2265
Fax: +380-44-206-2264

**United Kingdom and
Ireland** – Swindon
Phone: +44-8706-080208
Fax: +44-208-954-6234
Product Information Center:
Phone: +44-800-267-666
Fax: +44-208-420-8095



Tyco Electronics AMP GmbH
a TE Connectivity Ltd. company
AMPèrestr. 12-14
64625 Bensheim/Germany
Phone: +49-(0)6251-133-0
Fax: +49-(0)6251-133-1600

www.te.com
www.te.com/automotive
www.te.com/automotive/sensors
www.te.com/automotive/most
AMP MCP, TE Connectivity and
TE connectivity (logo) are trademarks.

Tyco Electronics AMP GmbH certified
acc. ISO 14001 and ISO/TS 16949:2002

© 2011 Tyco Electronics AMP GmbH
1307998-3 Revised 7-2011 4M ST



AUTOMOTIVE