

THIS DRAWING IS UNPUBLISHED. RELEASED FOR PUBLICATION  
 © COPYRIGHT - By - ALL RIGHTS RESERVED.

REVISIONS					
P	LTR	DESCRIPTION	DATE	DWN	APVD
F1		REVISED PER ECO-11-004917	11MAR11	RK	HMR
F2		REVISED PER ECO-17-008808	28FEB2018	RS	DR

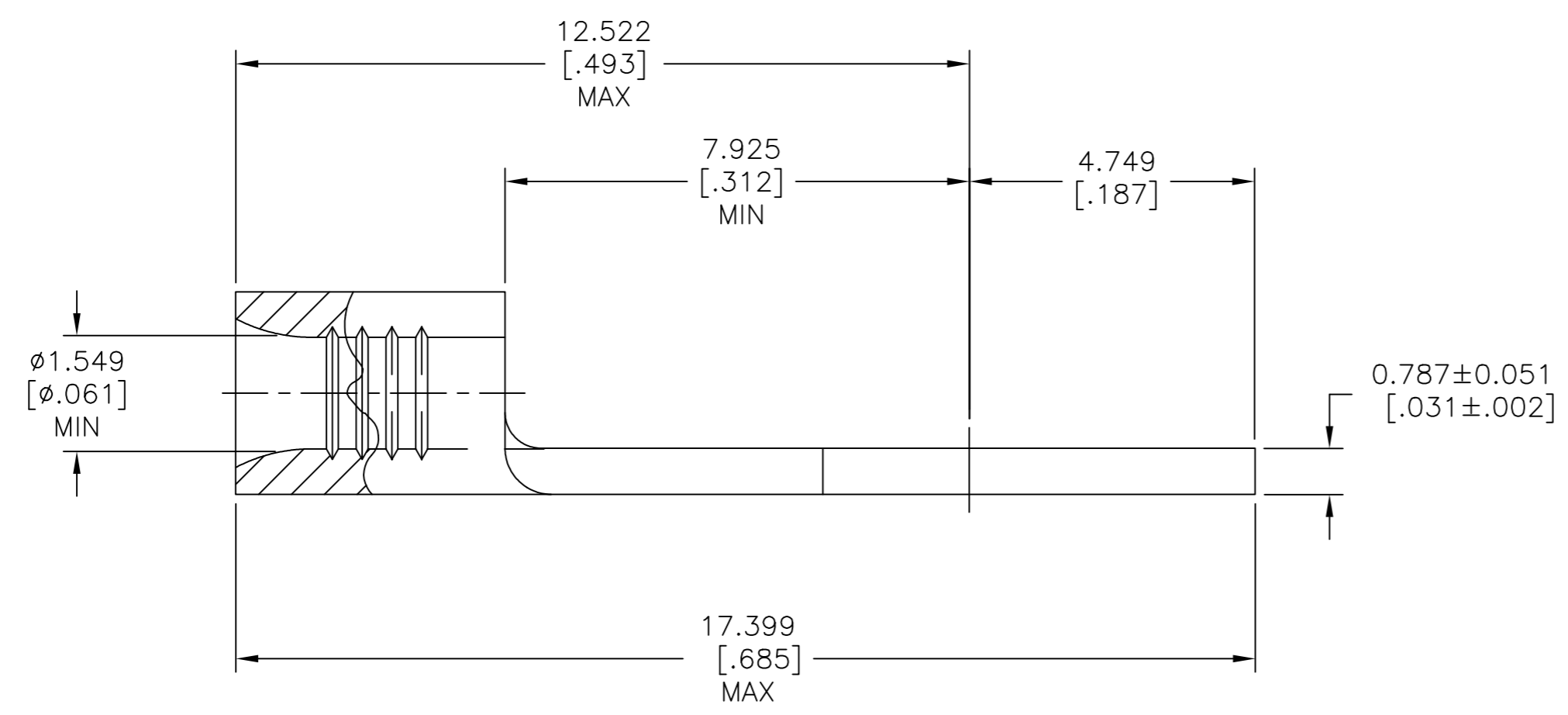
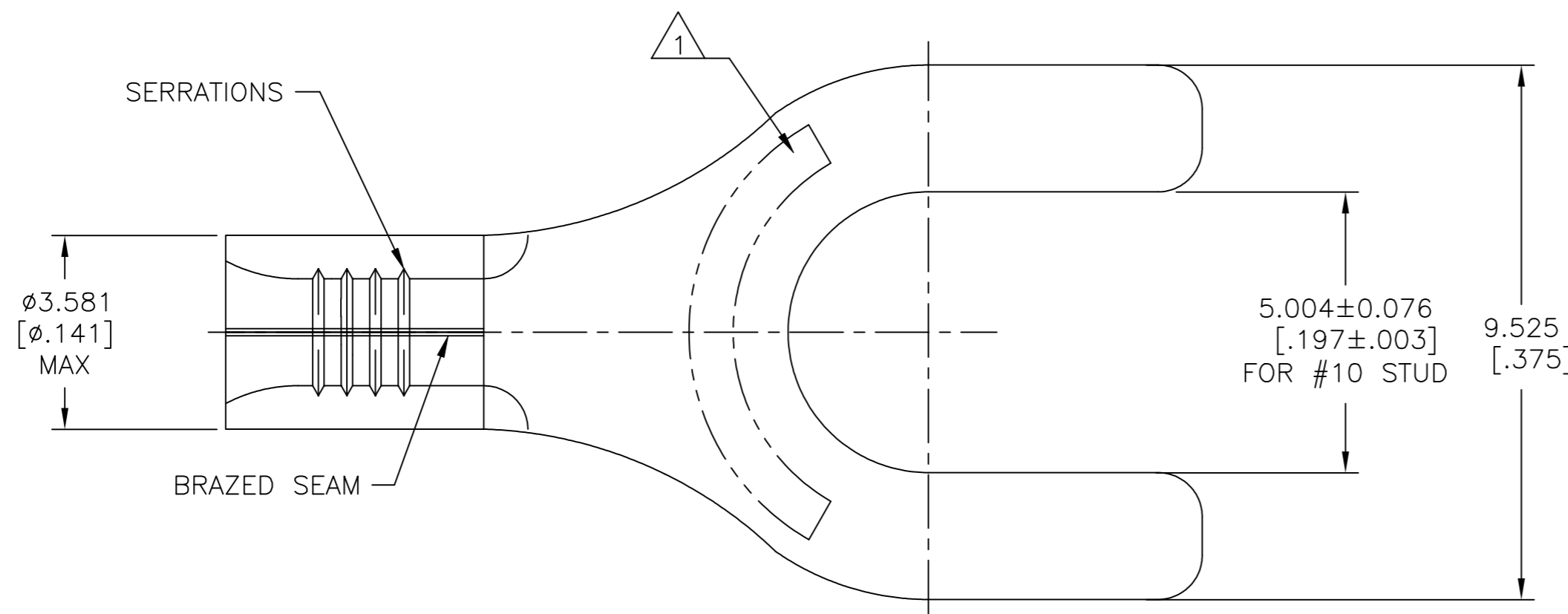

<b>AMP</b> WIRE RANGE	E13288 Listed
22-16 AWG SOLID OR STRANDED	22-16 AWG SOLID OR STRANDED
LR7189 Certified	MILITARY P/N AND CLASS
22-16 AWG SOLID OR STRANDED	NOT APPLICABLE

1 STAMP AMP 22-18\* APPROX AS SHOWN  
 22-16 TERMINALS ARE STAMPED 22-18 IN  
 ACCORDANCE WITH MILITARY SPECIFICATION  
 SAE AS7928, COMMERCIAL WIRE RANGE IS  
 22-18

AMP INCORPORATED  
 CUSTOMER SERVICE SYSTEMS

MAX RECOMMENDED OPERATING  
 TEMPERATURE:  
 170° C [338°F] MAX

FOR ADDITIONAL  
 PRODUCT INFORMATION OR  
 COPIES OF DRAWINGS  
 AND TECHNICAL DOCUMENTS

PRODUCT INFORMATION CENTER  
 1-800-522-6752

VOLTAGE RATING:  
 NOT APPLICABLE

FOR APPLICATION  
 TOOLING INFORMATION

TOOLING ASSISTANCE CENTER  
 1-800-722-1111

WIRE CROSS SECTIONAL AREA RANGE:  
 0.26-1.65mm<sup>2</sup> [509-3,260] CIR MILS  
 SOLID OR STRANDED

FOR ORDER ENTRY

1-800-526-5142

THIS DRAWING IS A CONTROLLED DOCUMENT FOR  
 AMP INCORPORATED. IT IS SUBJECT TO CHANGE  
 AND THE CONTROLLING ENGINEERING ORGANIZATION  
 SHOULD BE CONTACTED FOR THE LATEST REVISION.

5000	ON TAPE	2-34118-2
1000	LOOSE PIECE	34118
QUANTITY	PACKAGING TYPE	PART NO

THIS DRAWING IS A CONTROLLED DOCUMENT.		DWN TA BRINKMAN 3-26-93
DIMENSIONS: mm [INCHES]		CHK DA PATTERSON 3-26-93
TOLERANCES UNLESS OTHERWISE SPECIFIED:		APVD DE MILLER 3-26-93
0 PLC ± -		PRODUCT SPEC
1 PLC ± -		APPLICATION SPEC
2 PLC ± -		UL 486 A-B
3 PLC ± 0.127[.005]		
4 PLC ± -		
ANGLES ± -		
MATERIAL COPPER PER ASTM B 552 ANNEALED	FINISH TIN PLATE 0.00254[.000100] MIN THK PER ASTM B545	WEIGHT

TE Connectivity Ltd.			
NAME TERMINAL, SPADE™ TONGUE, SOLISTRAND™ 22-16 AWG			
SIZE A2	CAGE CODE 00779	DRAWING NO C=34118	RESTRICTED TO -
CUSTOMER DRAWING		SCALE 10:1	SHEET 1 of 1
		REV F2	