

CF-TA

Reflow Toggle Switch

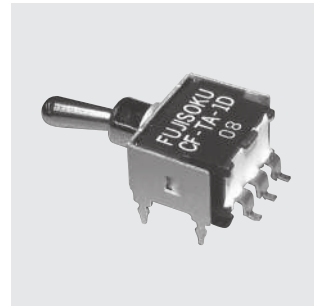

RoHS Compliant

Features

1. Industry's first toggle switch compatible with through-hole reflow soldering.
2. Compatible with pick and place machines.
3. Heat resistant resin for reflow and dip soldering.
4. Gold-plated contacts.

Specifications

Rating	Max.	48VAC / DC 50mA	(Resistive load)
	Min.	20mVAC / DC 1μA	
Initial contact resistance		100mΩ max.	(1.5mA 200μ VAC)
Dielectric strength		500VAC 1 minute	
Insulation resistance		500mΩ min.	(500VDC)
Electrical life		10,000 cycles at max. rating	
Operating temperature range		-40°C ~ +85°C	
Storage temperature range		-40°C ~ +85°C	

Part Numbering

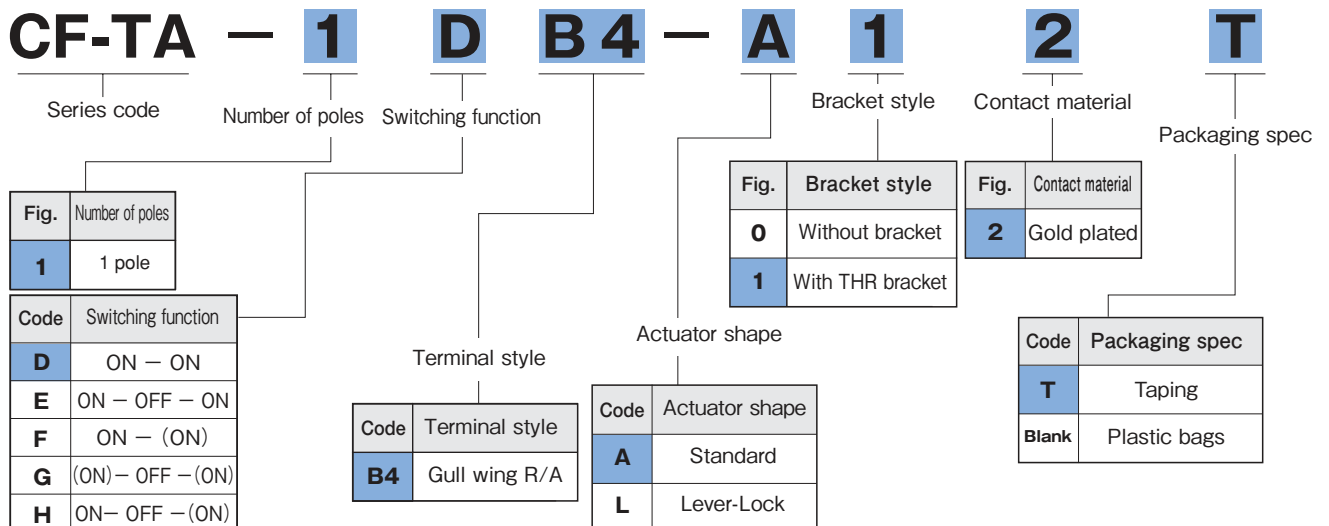

PC Hole Layouts

Standard

With THR bracket

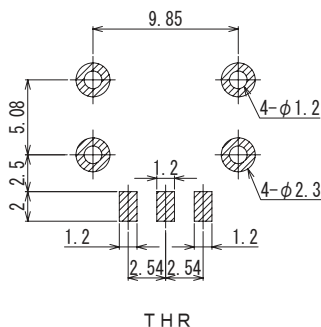

Without bracket

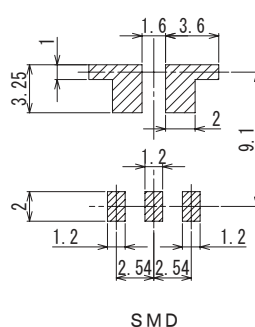

Locking Lever

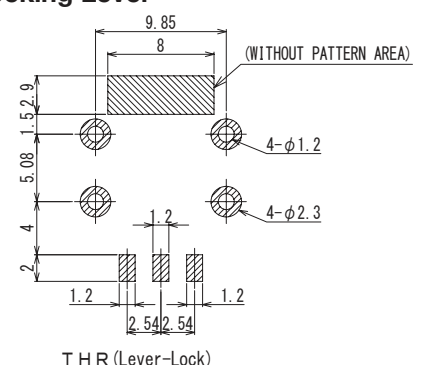

Outline dimensions

Standard

With THR bracket

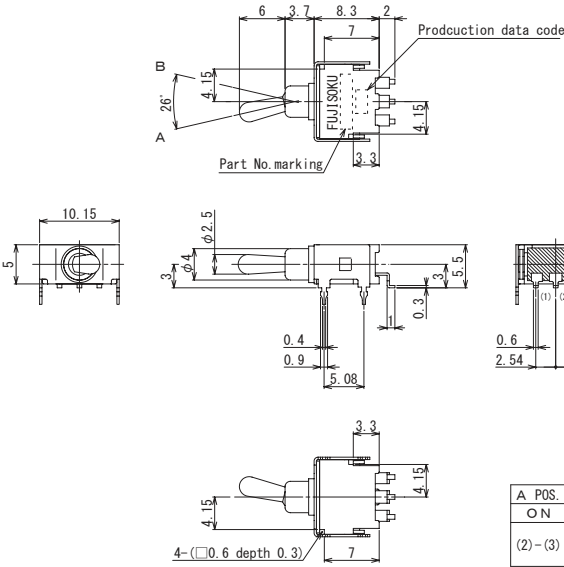

Without bracket

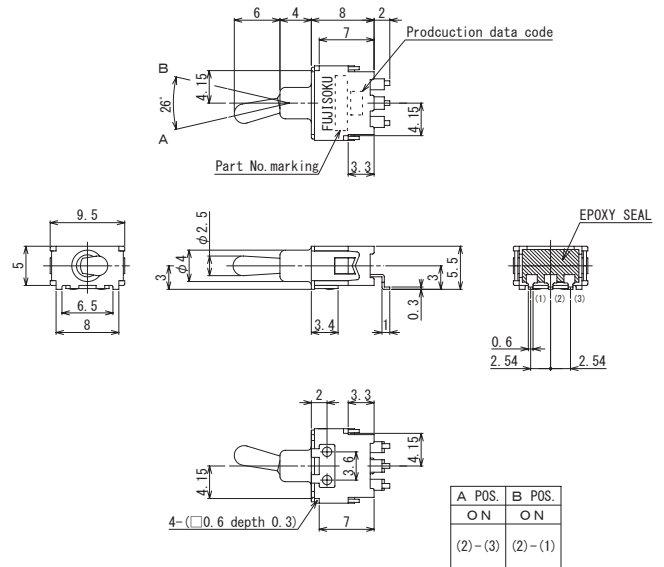

Locking Lever

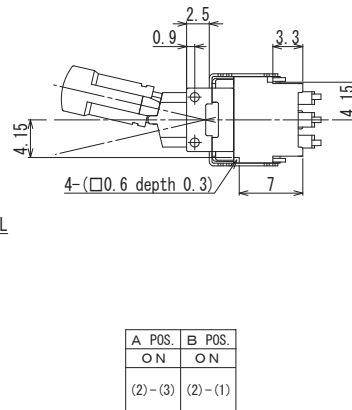
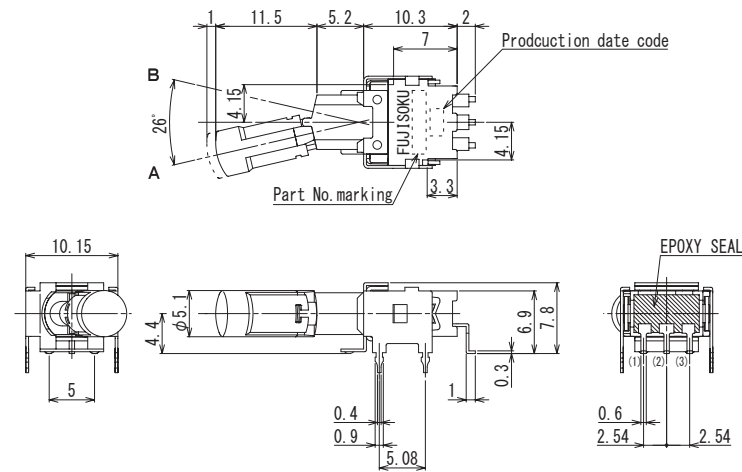

List of part numbers

Number of poles	Switching function	Actuator shape	Form of Packaging	Terminal style		Pieces in package
				SMD	THR	
1 pole	D	Standard	Taping	CF-TA-1DB4-A02T	CF-TA-1DB4-A12T	500pcs./reel
	D			CF-TA-1DB4-A02	CF-TA-1DB4-A12	20pcs./pack
	E		Plastic bags	CF-TA-1EB4-A02	CF-TA-1EB4-A12	20pcs./pack
	F			★CF-TA-1FB4-A02	★CF-TA-1FB4-A12	20pcs./pack
	G			★CF-TA-1GB4-A02	★CF-TA-1GB4-A12	20pcs./pack
	H			★CF-TA-1HB4-A02	★CF-TA-1HB4-A12	20pcs./pack
	D	Lever-lock	Taping	—	CF-TA-1DB4-L12T	250pcs./reel
			Plastic bags	—	CF-TA-1DB4-L12	20pcs./pack

Soldering

(1) Reflow soldering

Standard

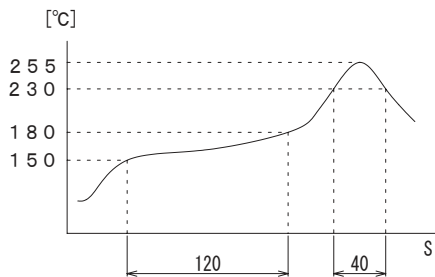

Reflow soldering: Two times max.

Locking Lever

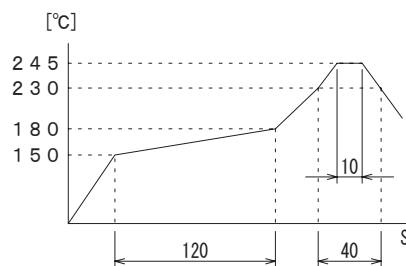

Reflow soldering: Two times max.

(2) Manual soldering

Device: Solder iron
380°C Max. 3sec Max.

Packaging Specifications

(1) Taping

Standard type: 500 pcs/reel.

Locking lever type: 250 pcs/reel.

One reel is packed into one carton (1 reel / carton).

The maximum number of consecutive missing pieces shall be 2.

Embossed tape dimensions are shown in the diagram below.

Fig.1 Embossed tape dimensions

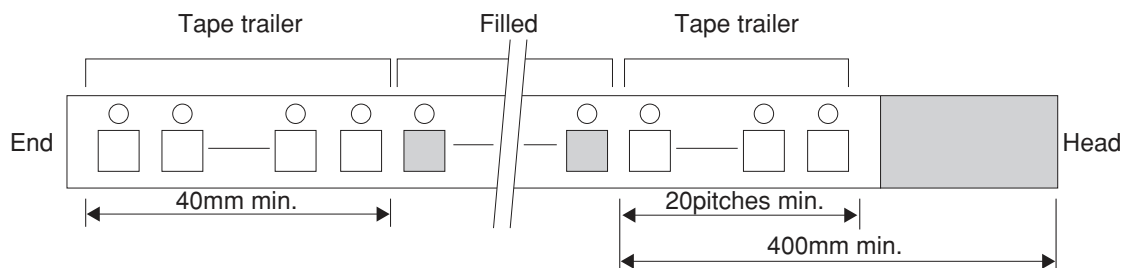

<Tape dimensions>

•Standard

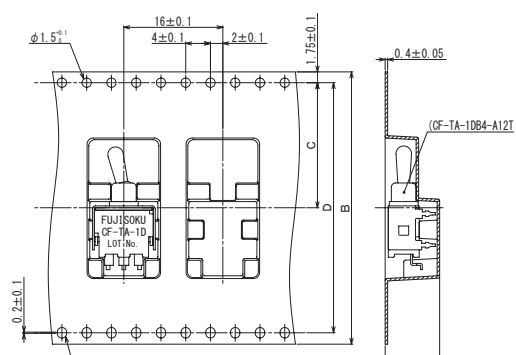

<Reel dimensions>

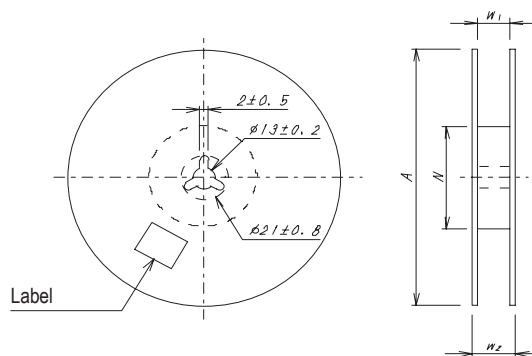

•Locking Lever

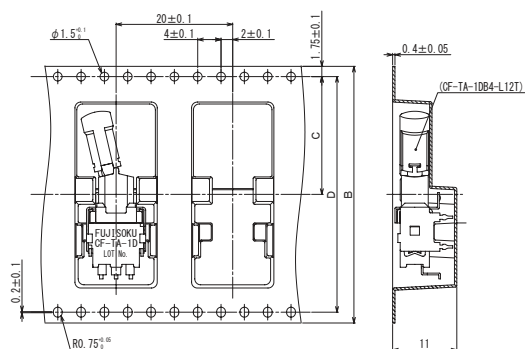

Unit (mm)

A	W ₁	W ₂	N
$\phi 330 \pm 2$	45.4 ± 1	49.4 ± 1	$\phi 80 \pm 1$

Unit (mm)

B	C	D
44	20.2 ± 0.1	40.4 ± 0.1

(2) Bulk

20 pcs. / plastic bag