

NHD-C12864KGZ-FSW-GBW

COG (Chip-On-Glass) Liquid Crystal Display Module

NHD-	Newhaven Display
C12864-	128 x 64 Pixels
KGZ-	Model
F-	Transflective
SW-	Side White LED Backlight
G-	STN - Gray
B-	6:00 Optimal View
W-	Wide Temperature
	RoHS Compliant

Newhaven Display International, Inc.

2661 Galvin Court,

Elgin IL, 60124

Ph: 847-844-8795

Fax: 847-844-8796

www.newhavendisplay.com

nhtech@newhavendisplay.com

nhsales@newhavendisplay.com

Document Revision History

Revision	Date	Description	Changed by
0	3/19/12	Initial Release	-
1	5/11/12	Electrical and Optical characteristics updated	AK
2	4/4/13	Backlight mating connector part number updated	AK
3	10/3/13	Example Code updated	ML
4	11/1/17	Mechanical Drawing and Electrical Characteristics Updated	SB
5	12/1/20	Updated Mechanical Drawing	AS

Functions and Features

- 128 x 64 pixels
- Built-in ST7565R controller
- 1/65 duty, 1/9 bias
- Parallel 8080 MPU interface
- RoHS Compliant

Mechanical Drawing

SYMBOL	REVISION	DATE

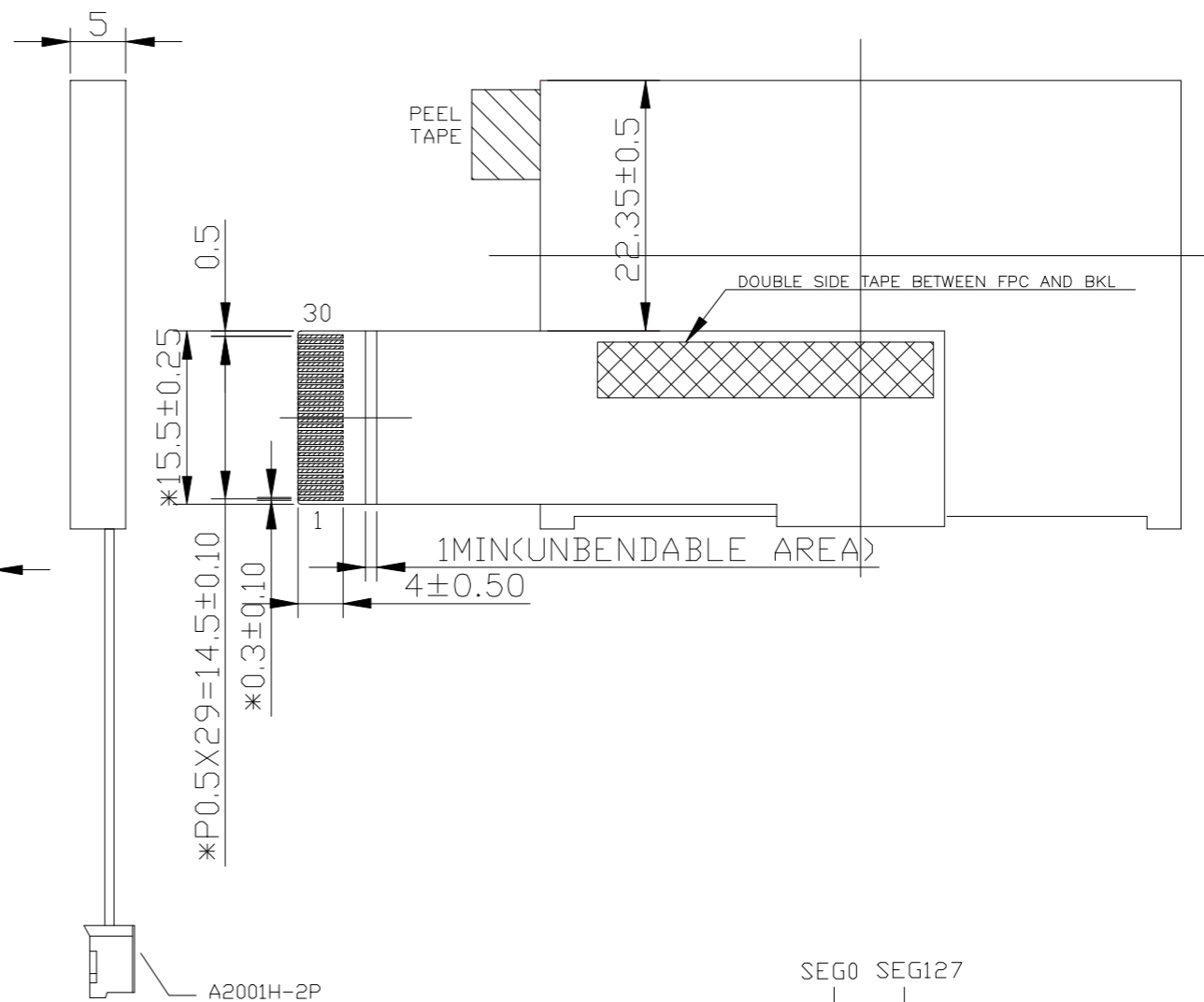
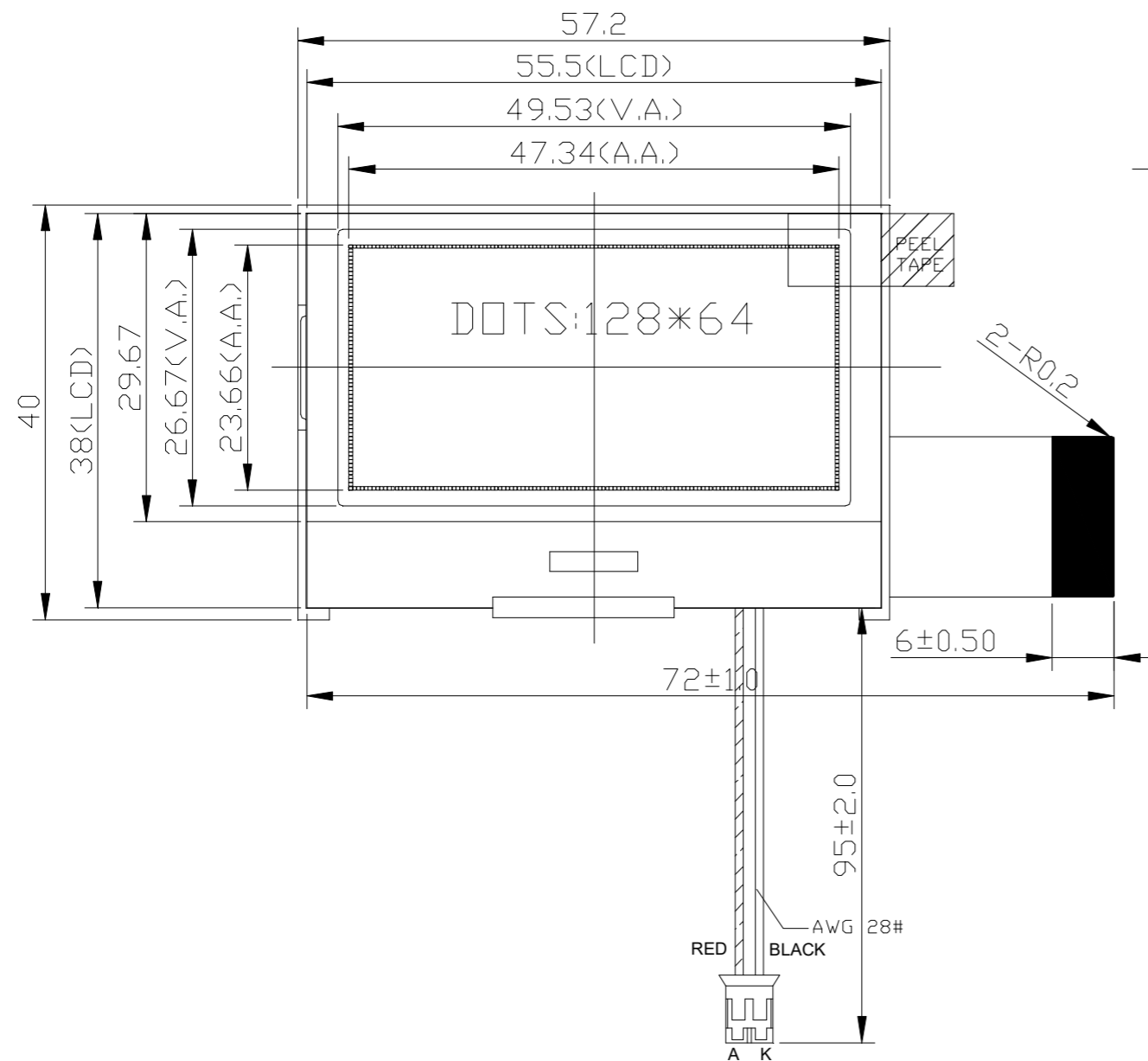

PIN	
NO.	SIGNAL
1	ESD-GND
2	/CS1
3	/RES
4	A0
5	/WR
6	/RD
7	D0
8	D1
9	D2
10	D3
11	D4
12	D5
13	D6
14	D7
15	VDD
16	VSS
17	VOUT
18	CAP3P
19	CAP1N
20	CAP1P
21	CAP2P
22	CAP2N
23	CAP4P
24	V4
25	V3
26	V2
27	V1
28	V0
29	ESD-GND
30	NC

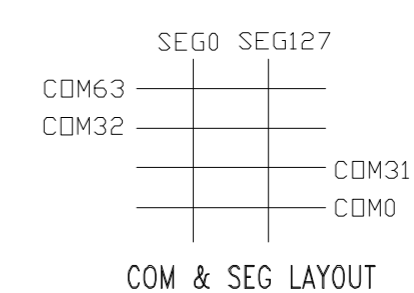

- Notes:**
- Driving: 1/64duty, 1/5bias
 - Voltage: VDD 3.0V, VLCD 8.8V
 - Display Type: STN Positive / Transflective / Gray
 - Optimal View: 6 O'Clock
 - Backlight: White LED, Edge Light
 - Driver IC: ST7565R

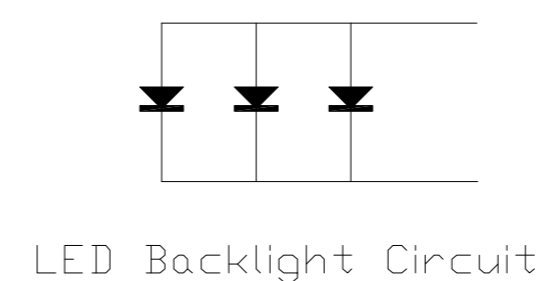
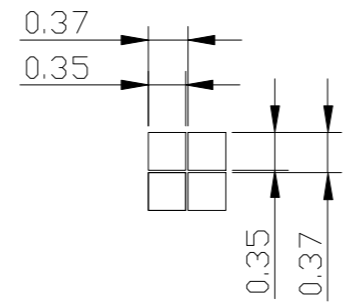

Standard Tolerance: (Unless otherwise specified) Linear: ±0.3mm			
	Drawing/Part Number: NHD-C12864KGZ-FSW-GBW	Revision: 1.0	
Unless otherwise specified: • Dimensions are in Millimeters • Third Angle Projection	Drawn By: A. Shah	Approved By: A. Shah	Size: A3
	Drawn Date: 12/01/2020	Approved Date: 12/01/2020	Scale: NS
Do Not Scale Drawing		Sheet 1 of 1	
This drawing is solely the property of Newhaven Display International, Inc. The information it contains is not to be disclosed, reproduced or copied in whole or part without written approval from Newhaven Display.			

Pin Description and Wiring Diagram

Pin No.	Symbol	External Connection	Function Description
1	ESD-GND	Power Supply	Ground (can be a No Connect)
2	/CS1	MPU	Active LOW Chip Select signal
3	/RES	MPU	Active LOW Reset signal
4	A0	MPU	Register Select: '0' = Command, '1' = Data
5	/WR	MPU	Active LOW Write signal
6	/RD	MPU	Active LOW Read signal
7-14	D0-D7	MPU	8-bit bi-directional data bus
15	V _{DD}	Power Supply	Supply Voltage for LCD and Logic (3.0V)
16	V _{SS}	Power Supply	Ground
17	V _{OUT}	Power Supply	1.0uF-2.2uF Capacitor to V _{SS}
18	C ₃₊	Power Supply	1.0uF-2.2uF Capacitor to C ₁₋ (Pin-19)
19	C ₁₋	Power Supply	1.0uF-2.2uF Capacitor to C ₃₊ (Pin-18) and C ₁₊ (Pin-20)
20	C ₁₊	Power Supply	1.0uF-2.2uF Capacitor to C ₁₋ (Pin-19)
21	C ₂₊	Power Supply	1.0uF-2.2uF Capacitor to C ₂₋ (Pin-22)
22	C ₂₋	Power Supply	1.0uF-2.2uF Capacitor to C ₂₊ (Pin-21) and C ₄₊ (Pin-23)
23	C ₄₊	Power Supply	1.0uF-2.2uF Capacitor to C ₂₋ (Pin-22)
24	V ₄	Power Supply	0.1uF-1.0uF Capacitor to V _{DD} or V _{SS}
25	V ₃	Power Supply	0.1uF-1.0uF Capacitor to V _{DD} or V _{SS}
26	V ₂	Power Supply	0.1uF-1.0uF Capacitor to V _{DD} or V _{SS}
27	V ₁	Power Supply	0.1uF-1.0uF Capacitor to V _{DD} or V _{SS}
28	V ₀	Power Supply	0.1uF-1.0uF Capacitor to V _{DD} or V _{SS}
29	ESD-GND	Power Supply	Ground (can be a No Connect)
30	NC	-	No Connect

Recommended LCD connector: 0.5mm pitch, 30 conductor FFC. Molex p/n: 52892-3095

Backlight connector: A2001H-2P **Mates with:** A2001WR-2P, A2001WR-S-2P, A2001WV-2P, A2001WV-S-2P

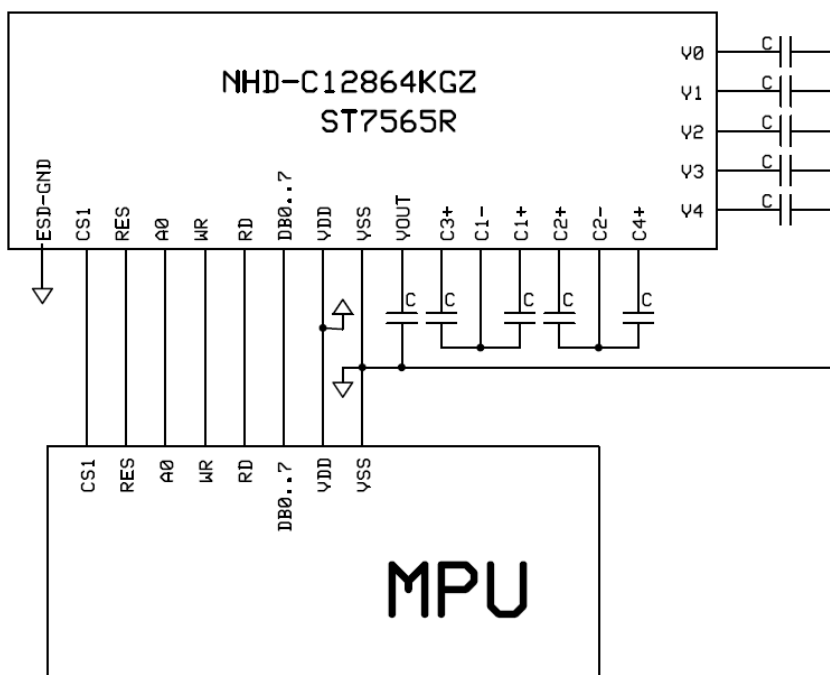

Electrical Characteristics

Item	Symbol	Condition	Min.	Typ.	Max.	Unit
Operating Temperature Range	T _{OP}	Absolute Max	-20	-	+70	°C
Storage Temperature Range	T _{ST}	Absolute Max	-30	-	+80	°C
Supply Voltage	V _{DD}	-	2.8	3.0	3.3	V
Supply Current	I _{DD}	V _{DD} =3.0V	0.2	0.5	1	mA
Supply for LCD (contrast)*	V _{LCD}	T _{OP} =25°C	8.6	8.8	9.0	V
"H" Level input	V _{IH}	-	0.8*V _{DD}	-	V _{DD}	V
"L" Level input	V _{IL}	-	V _{SS}	-	0.2*V _{DD}	V
"H" Level output	V _{OH}	-	0.8*V _{DD}	-	V _{DD}	V
"L" Level output	V _{OL}	-	V _{SS}	-	0.2*V _{DD}	V
Backlight Supply Current**	I _{LED}	-	-	60	90	mA
Backlight Supply Voltage	V _{LED}	I _{LED} = 60mA	2.8	3.0	3.2	V

*User should employ SW/HW methods for tuning contrast. (Refer to Electronic Volume Register)

**The LED of the backlight is driven by current; drive voltage is for reference only. Drive voltage must be selected to ensure backlight current drain is below MAX level stated.

Optical Characteristics

Item	Symbol	Condition	Min.	Typ.	Max.	Unit
Optimal Viewing Angles	Top	CR ≥ 2	-	40	-	°
	Bottom		-	60	-	°
	Left		-	60	-	°
	Right		-	60	-	°
Contrast Ratio	CR	-	2	5	-	-
Response Time	Rise	T _{OP} = 25°C	-	150	250	ms
	Fall		-	200	300	ms

Controller Information

Built-in ST7565R controller.

Please download specification at http://www.newhavendisplay.com/app_notes/ST7565R.pdf

Timing Characteristics

8080 MPU Interface (VDD=3.3V)

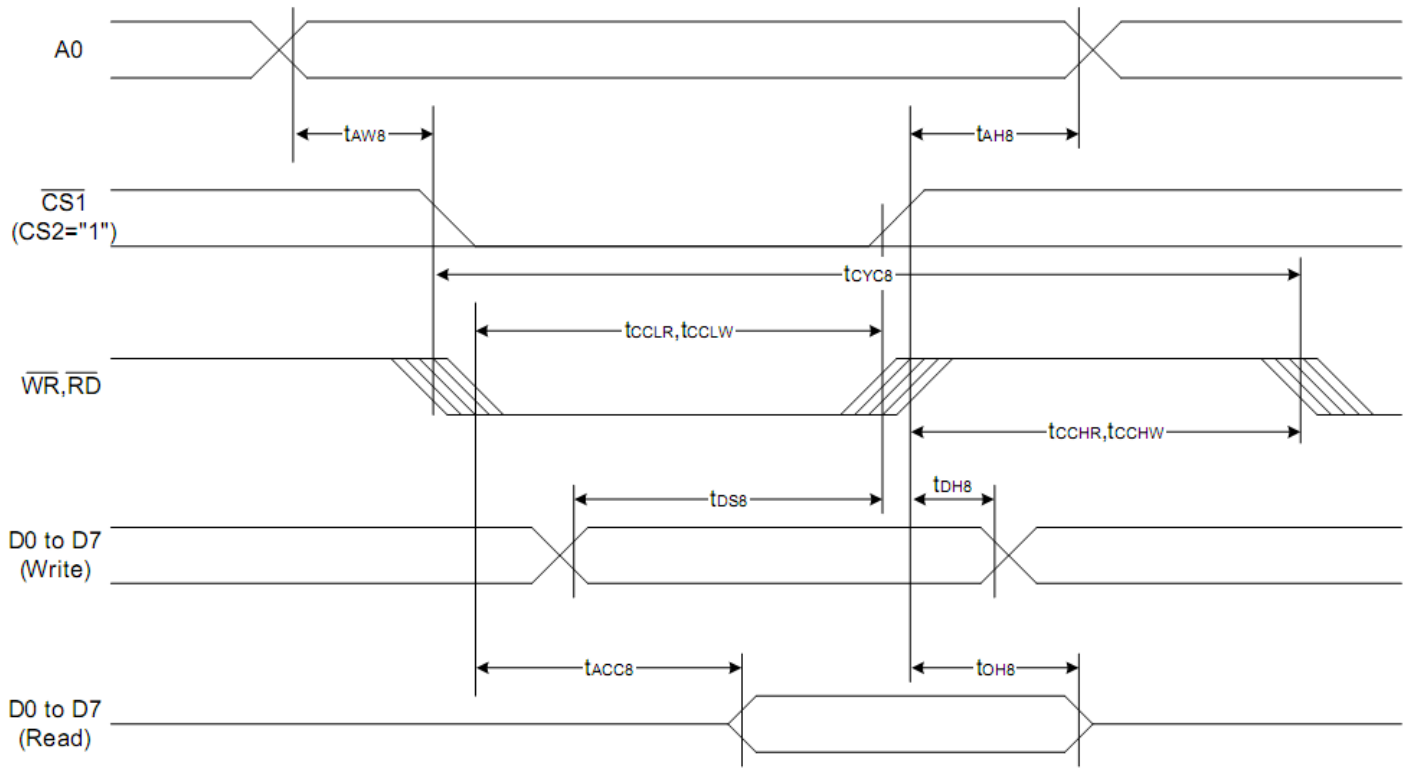

Item	Signal	Symbol	Condition	Rating		Units
				Min.	Max.	
Address hold time	A0	t_{AH8}		0	—	Ns
Address setup time		t_{AW8}		0	—	
System cycle time		t_{CYC8}		240	—	
Enable L pulse width (WRITE)	WR	t_{CCLW}		80	—	
Enable H pulse width (WRITE)		t_{CCHR}		80	—	
Enable L pulse width (READ)	RD	t_{CCLR}		140	—	
Enable H pulse width (READ)		t_{CCHR}		80	—	
WRITE Data setup time	D0 to D7	t_{DS8}		40	—	
WRITE Address hold time		t_{DH8}		0	—	
READ access time		t_{ACC8}	$C_L = 100 \text{ pF}$	—	70	
READ Output disable time		t_{OH8}	$C_L = 100 \text{ pF}$	5	50	

Table of Commands

Command	Command Code									Function			
	A0	/RD	/WR	D7	D6	D5	D4	D3	D2		D1	D0	
(1) Display ON/OFF	0	1	0	1	0	1	0	1	1	1	0	1	LCD display ON/OFF 0: OFF, 1: ON
(2) Display start line set	0	1	0	0	1	Display start address					0	Sets the display RAM display start line address	
(3) Page address set	0	1	0	1	0	1	Page address				0	Sets the display RAM page address	
(4) Column address set upper bit	0	1	0	0	0	0	1	Most significant column address			0	Sets the most significant 4 bits of the display RAM column address.	
Column address set lower bit				0	0	0	0	Least significant column address			0	Sets the least significant 4 bits of the display RAM column address.	
(5) Status read	0	0	1	Status			0	0	0	0	0	Reads the status data	
(6) Display data write	1	1	0	Write data						0	Writes to the display RAM		
(7) Display data read	1	0	1	Read data						0	Reads from the display RAM		
(8) ADC select	0	1	0	1	0	1	0	0	0	0	0	1	Sets the display RAM address SEG output correspondence 0: normal, 1: reverse
(9) Display normal/reverse	0	1	0	1	0	1	0	0	1	1	0	1	Sets the LCD display normal/ reverse 0: normal, 1: reverse
(10) Display all points ON/OFF	0	1	0	1	0	1	0	0	1	0	0	1	Display all points 0: normal display 1: all points ON
(11) LCD bias set	0	1	0	1	0	1	0	0	0	1	0	1	Sets the LCD drive voltage bias ratio 0: 1/9 bias, 1: 1/7 bias (ST7565R)
(12) Read-modify-write	0	1	0	1	1	1	0	0	0	0	0	0	Column address increment At write: +1 At read: 0
(13) End	0	1	0	1	1	1	0	1	1	1	0	0	Clear read/modify/write
(14) Reset	0	1	0	1	1	1	0	0	0	1	0	0	Internal reset
(15) Common output mode select	0	1	0	1	1	0	0	0	*	*	*	1	Select COM output scan direction 0: normal direction 1: reverse direction
(16) Power control set	0	1	0	0	0	1	0	1	Operating mode		0	0	Select internal power supply operating mode
(17) V ₀ voltage regulator internal resistor ratio set	0	1	0	0	0	1	0	0	Resistor ratio		0	0	Select internal resistor ratio(Rb/Ra) mode
(18) Electronic volume mode set	0	1	0	1	0	0	0	0	0	0	0	1	Set the V ₀ output voltage electronic volume register
Electronic volume register set				0	0	Electronic volume value					0		
(19) Sleep mode set	0	1	0	1	0	1	0	1	1	0	0	1	0: Sleep mode, 1: Normal mode
(20) Booster ratio set	0	1	0	1	1	1	1	1	0	0	0	0	select booster ratio 00: 2x,3x,4x 01: 5x 11: 6x
				0	0	0	0	0	0	0	0	step-up value	
(21) NOP	0	1	0	1	1	1	0	0	0	1	1	1	Command for non-operation
(22) Test	0	1	0	1	1	1	1	*	*	*	*	*	Command for IC test. Do not use this command

Example Initialization Code

```
/**
 *
 */

void comm_out(unsigned char c)
{
    CS1 = 0;
    AO = 0;           //LOW = command
    WRT = 0;
    P1 = c;
    WRT = 1;
    CS1 = 1;
}

/**
 *
 */

void data_out(unsigned char d)
{
    CS1 = 0;
    AO = 1;           //HIGH = data
    WRT = 0;
    P1 = d;
    WRT = 1;
    CS1 = 1;
}

/**
 *
 */

void disp()
{
    unsigned int i, j;
    unsigned char page=0xB0;
    for(i=0;i<8;i++)           //fill display with checkerboard pattern
    {
        comm_out(0x10);       //set column address
        comm_out(0x00);       //set column address
        comm_out(page);       //set page address
        for(j=0;j<64;j++)
        {
            data_out(0xAA);
            data_out(0x55);
        }
        page++;
    }
}

/**
 *
 */
```



```

/*****
/***** NHD-C12864KGZ DISPLAY INITIALIZATION *****/
/*****

void init()
{
    RDD = 1;
    WRT = 1;
    CS1 = 0;
    RST = 0;
    delay(150);
    RST = 1;
    delay(150);

    comm_out(0xA2); //added 1/9 bias
    comm_out(0xA0); //ADC segment driver direction (A0=Normal)
    comm_out(0xC0); //COM output scan direction (C0=Normal)
    comm_out(0x25); //resistor ratio
    comm_out(0x81); //electronic volume mode set
    comm_out(0x15); //electronic volume register set
    comm_out(0x2F); //operating mode
    comm_out(0x40); //start line set
    comm_out(0xAF); //display ON

    delay(10);
}

*****/

```

Quality Information

Test Item	Content of Test	Test Condition	Note
High Temperature storage	Endurance test applying the high storage temperature for a long time.	+80°C , 96hrs	2
Low Temperature storage	Endurance test applying the low storage temperature for a long time.	-30°C , 96hrs	1,2
High Temperature Operation	Endurance test applying the electric stress (voltage & current) and the high thermal stress for a long time.	+70°C , 96hrs	2
Low Temperature Operation	Endurance test applying the electric stress (voltage & current) and the low thermal stress for a long time.	-20°C , 96hrs	1,2
High Temperature / Humidity Storage	Endurance test applying the electric stress (voltage & current) and the high thermal with high humidity stress for a long time.	+40°C , 90% RH , 96hrs	1,2
Thermal Shock resistance	Endurance test applying the electric stress (voltage & current) during a cycle of low and high thermal stress.	-0°C 30min -> 25°C 5min -> 50°C 30min = 1 cycle For 10 cycles	
Vibration test	Endurance test applying vibration to simulate transportation and use.	10-55Hz, 1.5mm amplitude. 60 sec in each of 3 directions X,Y,Z For 15 minutes	3
Static electricity test	Endurance test applying electric static discharge.	VS=800V, RS=1.5kΩ, CS=100pF One time	

Note 1: No condensation to be observed.

Note 2: Conducted after 4 hours of storage at 25°C, 0%RH.

Note 3: Test performed on product itself, not inside a container.

Precautions for using LCDs/LCMs

See Precautions at www.newhavendisplay.com/specs/precautions.pdf

Warranty Information

See Terms & Conditions at http://www.newhavendisplay.com/index.php?main_page=terms