

IB IL 24 SEG/F-D ...

Inline Segment Terminal With Fuse and Diagnostics

AUTOMATIONWORX

Data Sheet
5658_en_03

© PHOENIX CONTACT - 01/2007

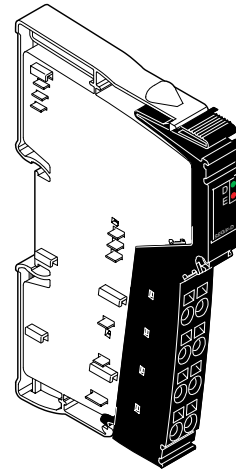

Description

The terminal is designed for use within an Inline station.

The segment terminal is used to create a protected partial circuit (segment circuit) within the main circuit.

The terminal is not used to supply power and has no elements for protection against polarity reversal and surge voltage.

This terminal has an LED for diagnostics and occupies two input data bits, which are used to indicate the presence of the supply voltage and the state of the fuse.

Features

- Automatic creation of a segment circuit within the main circuit
- Segment circuit protected by an internal fuse
- Diagnostic indicators
- Mapping of the status of the internal fuse and the main voltage to the input data



This data sheet is only valid in association with the IB IL SYS PRO UM E user manual or the Inline system manual for your bus system.



Make sure you always use the latest documentation.
It can be downloaded at www.download.phoenixcontact.com.
A conversion table is available on the Internet at
www.download.phoenixcontact.com/general/7000_en_00.pdf.



This data sheet is valid for all products listed on the following page:

Ordering Data

Products

Description	Type	Order No.	Pcs./Pck.
Inline Segment terminal with fuse and diagnostics; without accessories transmission speed of 500 kbps	IB IL 24 SEG/F-D	2836683	1
Inline Segment terminal with fuse and diagnostics; complete with accessories (connector and labeling field); transmission speed of 500 kbps	IB IL 24 SEG/F-D-PAC	2861904	1
Inline Segment terminal with fuse and diagnostics; without accessories transmission speed of 2 Mbps	IB IL 24 SEG/F-D-2MBD	2855033	1
Inline Segment terminal with fuse and diagnostics; complete with accessories (connector and labeling field); transmission speed of 2 Mbps	IB IL 24 SEG/F-D-2MBD-PAC	2861946	1



One of the connectors listed below is needed for the complete fitting of the IB IL 24 SEG/F-D and IB IL 24 SEG/F-D-2MBD terminals.

Accessories

Description	Type	Order No.	Pcs./Pkt
Connector (black, w/o color print)	IB IL SCN-PWR IN	2727462	10
Connector (black, with color print)	IB IL SCN-PWR IN-CP	2727637	10
Fuse	SI 5 x20 6,300 A T	5030512	10

Documentation

Description	Type	Order No.	Pcs./Pkt
"Configuring and Installing the INTERBUS Inline Product Range" user manual	IB IL SYS PRO UM E	2743048	1
"Automation Terminals of the Inline Product Range" user manual	IL SYS INST UM E	2698737	1

Technical Data

General Data

Housing dimensions (width x height x depth)	12.2 mm x 120 mm x 71.5 mm
Weight	44 g, approximately (without connector), 59 g, approximately (with connector)
Operating mode	Process data mode with 2 bits
Ambient temperature (operation)	-25°C to +55°C
Ambient temperature (storage/transport)	-25°C to +85°C
Permissible humidity (operation/storage/transport)	10% to 95%, according to DIN EN 61131-2
Air pressure (operation/storage/transport)	70 kPa to 106 kPa (up to 3000 m above sea level)
Degree of protection	IP20 according to IEC 60529
Protection class	Class 3 according to VDE 0106, IEC 60536
Connection data for Inline connector	
Connection method	Spring-cage terminals
Conductor cross section	0.2 mm ² to 1.5 mm ² (solid or stranded), 24 - 16 AWG

Interface

Local bus	Through data routing
-----------	----------------------

Transmission Speed

IB IL 24 SEG/F-D	500 kbps
IB IL 24 SEG/F-D-PAC	500 kbps
IB IL 24 SEG/F-D-2MBD	2 Mbps
IB IL 24 SEG/F-D-2MBD-PAC	2 Mbps

Power Consumption

	500 kbps	2 Mbps
Communications power U_L	7.5 V DC	7.5 V DC
Current consumption at U_L	25 mA, maximum	45 mA, maximum
Power consumption at U_L	0.19 W, maximum	0.34 W, maximum
Main voltage U_M	24 V DC (nominal value)	24 V DC (nominal value)
Nominal current consumption at U_M	4.0 A (nominal value)	4.0 A (nominal value)

Supply of the Module Electronics and the I/O Through the Bus Coupler/Power Terminal (U_L , U_M)

Connection method	Through potential routing
-------------------	---------------------------

24 V I/O Supply (U_M , U_S)

The main voltage U_M is supplied at the bus coupler or at a power terminal. The segment voltage U_S is provided automatically at this segment terminal and protected by the internal fuse.

Connections for a supply voltage are not provided on the segment terminal. The terminal points are **only** provided for measuring purposes.

Permissible Total Current in the Potential Jumpers of the Main and Segment Circuit/Nominal Current of the Terminal

	500 kbps	2 Mbps
Permissible total current in the potential jumpers	6.3 A	5.4 A
Nominal current of the terminal	4.0 A	4.0 A
Tolerance	+10%	+10%



The terminal is supplied with a 6.3 A slow-blow fuse.

Power Dissipation

Formula to Calculate the Power Dissipation of the Electronics (500 kbps)

$P_{TOT} = 0.180 \text{ W} + I_L^2 \times R_F$
 Where
 P_{TOT} Total power dissipation in the terminal
 I_L Load current in the segment circuit
 R_F Resistance of the fuse
 The resistance of the fuse R_F for a 6.3 AT fuse is approximately 12 mΩ.
 The power dissipation of the electronics for a theoretical maximum current of 6.3 A (nominal current = 4.0 A) is calculated as follows:
 $P_{TOT} = 0.18 \text{ W} + 39.69 \text{ A}^2 \times 0.012 \text{ } \Omega = 0.66 \text{ W}$

Formula to Calculate the Power Dissipation of the Electronics (2 Mbps)

$P_{TOT} = 0.34 \text{ W} + I_L^2 \times R_F$
 Where
 P_{TOT} Total power dissipation in the terminal
 I_L Load current in the segment circuit
 R_F Resistance of the fuse
 The resistance of the fuse R_F for a 6.3 AT fuse is approximately 12 mΩ.
 The power dissipation of the electronics for a theoretical maximum current of 5.4 A (nominal current = 4.0 A) is calculated as follows:
 $P_{TOT} = 0.34 \text{ W} + 29.16 \text{ A}^2 \times 0.012 \text{ } \Omega = 0.68 \text{ W}$

Power Dissipation of the Housing (P_{HOU}) (500 kbps and 2 Mbps)

$P_{HOU} = 0.7 \text{ W}$ in the total permissible ambient temperature range

Typical Power Dissipation of the Electronics Depending on the Load Current in the Segment Circuit

500 kbps

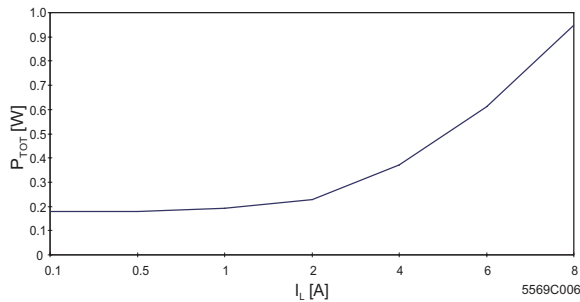

P [W] Power dissipation in W
 I_L [A] Load current in the segment circuit in A
 This test was carried out with a 6.3 AT fuse.

2 Mbps

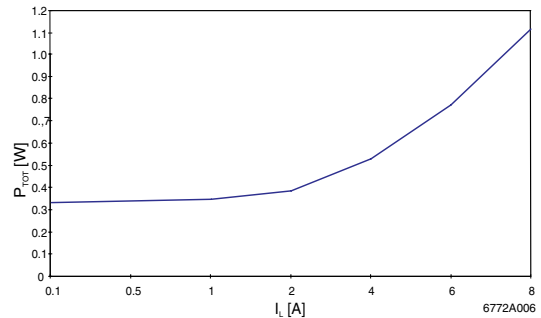

P [W] Power dissipation in W
 I_L [A] Load current in the segment circuit in A
 This test was carried out with a 6.3 AT fuse.

Derating of the Load Current in the Segment Circuit

No derating

Safeguards

Overload/short circuit in the segment circuit

Fuse 5 x 20 with 6.3 A slow-blow



Fuses with other values can also be used. The maximum fuse value must not exceed 6.3 A.



Note for the selection of fuses:
 For fuses with a value greater than 2 A, only slow-blow fuses may be used.

Surge voltage

Protection against polarity reversal

Protective elements in the power terminal or the bus coupler

Protective elements in the power terminal or the bus coupler

Electrical Isolation/Isolation of the Voltage Areas



To provide electrical isolation between the logic level and the I/O area, it is necessary to supply these areas via the bus coupler or via the bus coupler and a power terminal from separate power supply units. Interconnection of the power supply units in the 24 V area is not permitted. Please also observe the GND/PE connections on the power supply units (see also user manual).

Common Potentials

The 24 V main voltage, 24 V segment voltage, and GND have the same potential. FE is a separate potential area.

Separate Potentials in the System Consisting of Bus Coupler/Power Terminal and I/O Terminal

- Test Distance

5 V supply incoming remote bus/7.5 V supply (bus logic)

5 V supply outgoing remote bus/7.5 V supply (bus logic)

7.5 V supply (bus logic)/24 V supply (I/O)

24 V supply (I/O)/functional earth ground

- Test Voltage

500 V AC, 50 Hz, 1 min.

500 V AC, 50 Hz, 1 min.

500 V AC, 50 Hz, 1 min.

500 V AC, 50 Hz, 1 min.

Error Messages to the Higher-Level Control or Computer System

I/O error message if fuse has blown or is missing

I/O error message if supply voltage U_M is not present

Approvals

For the latest approvals, please visit www.download.phoenixcontact.com.

Local Diagnostic and Status Indicators and Terminal Point Assignment

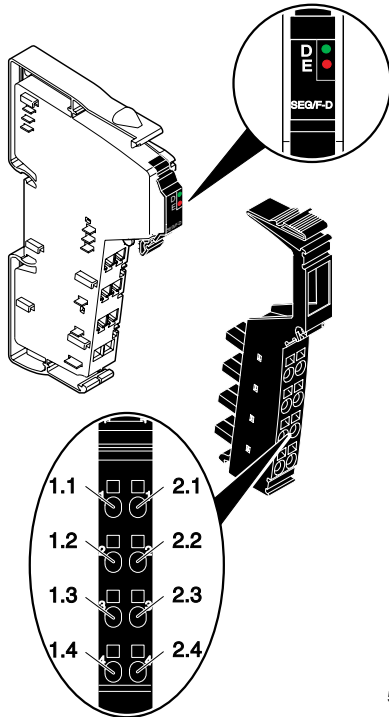

5658B003

Figure 1 Terminal with appropriate connector

Local Diagnostic Indicators

Des.	Color	Meaning
D	Green	Diagnostics
	ON:	Bus active
	Flashing:	
	0.5 Hz:	Communications power present, Bus not active
	2 Hz:	Communications power present, supply voltage U_M not present or fuse has blown.
4 Hz:	Communications power present, local bus error	
OFF:	Communications power not present, Bus not active	
E	Red	Fuse in segment circuit U_S
	OFF:	Fuse OK
	ON:	Fuse has blown



If supply voltage U_M is not present and the fuse has blown or is missing, an I/O error message is generated on the higher-level control or computer system.



A blown or missing fuse is indicated by both diagnostic indicators. The red E LED lights up and the green D LED flashes at 2 Hz.

Function Identification

Black

2 Mbps: white stripe in the vicinity of the LED D

Terminal Point Assignment

Terminal Point	Assignment
1.1, 2.1	Segment voltage U_S (after the fuse)
1.2, 2.2	Main voltage U_M
1.3, 2.3	GND of the supply voltages
1.4, 2.4	Functional earth ground (FE)



The terminal points are **only** provided for measuring purposes.

Internal Circuit Diagram

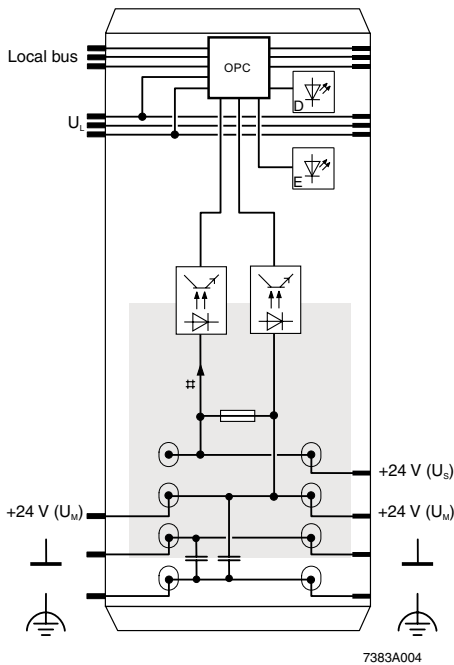







Figure 2 Internal wiring of the terminal points

Key:

-  Protocol chip
(bus logic including voltage conditioning)
-  LED with details of the indicator designation
"D" or "E" (see page 5)
-  Optocoupler
-  Fuse
-  Capacitive connection to functional earth
ground (FE)
-  Electrically isolated area



Other symbols used are explained in the IB IL SYS PRO UM E user manual or the system manual for your bus system.

Programming Data

Local Bus (INTERBUS)

ID code	BE _{hex} (190 _{dec})
Length code	C2 _{hex}
Process data channel	2 bits
Input address area	2 bits
Output address area	0 bits
Parameter channel (PCP)	0 bits
Register length (bus)	2 bits

Other Bus Systems



For the programming data/configuration data of other bus systems, please refer to the corresponding electronic device data sheet (e.g., GSD, EDS).

Process Data

Assignment of IN Process Data



The IN process data only maps the status of the fuse and the main voltage.

(Byte.bit) view		0.1	0.0
Assignment	Main voltage U_M present, fuse OK	1	1
	Main voltage U_M present, fuse blown or missing	1	0
	Main voltage U_M not present	0	0



For the assignment of the illustrated (byte.bit) - view to your INTERBUS control or computer system, please refer to the DB GB IBS SYS ADDRESS data sheet, Order No. 9000990.

© PHOENIX CONTACT 01/2007