

THIS DRAWING IS UNPUBLISHED. RELEASED FOR PUBLICATION 2009  
 © COPYRIGHT 2009 BY - ALL RIGHTS RESERVED.

REVISIONS					
P	LTR	DESCRIPTION	DATE	DWN	APVD
A5		ECR-10-005196	11FEB2010	VG	BR
A6		ECR-16-015318	16AUG2017	GR	MKO
A7		ECR-18-004438	06APR2018	GCM	JB

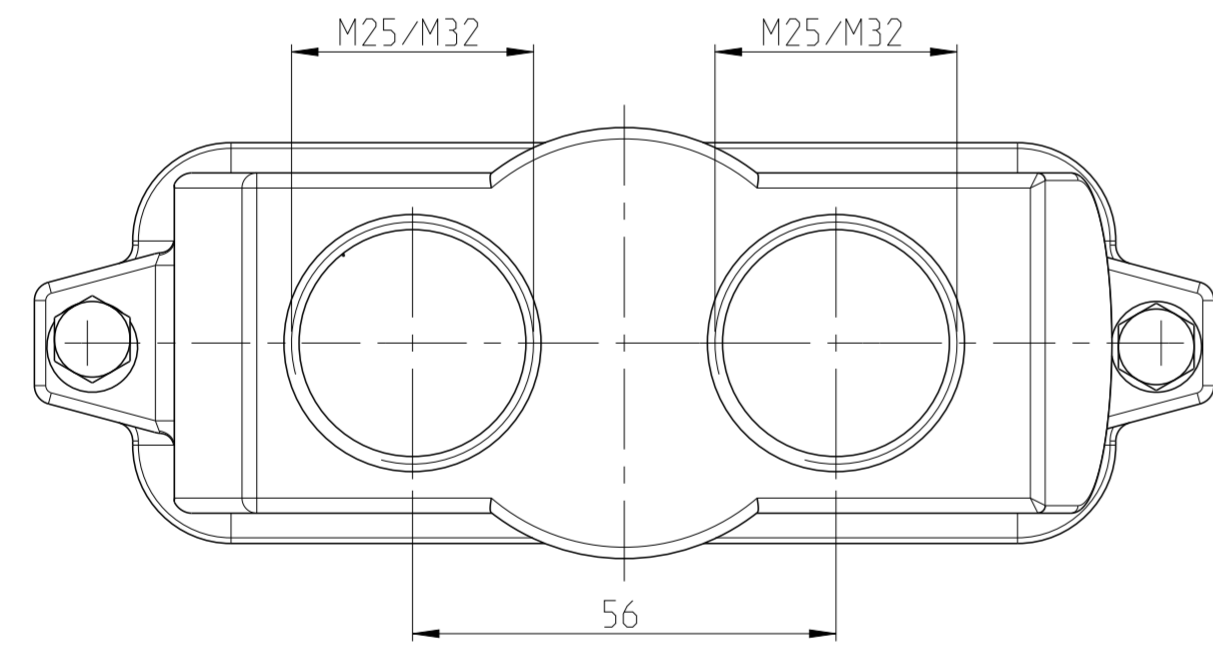
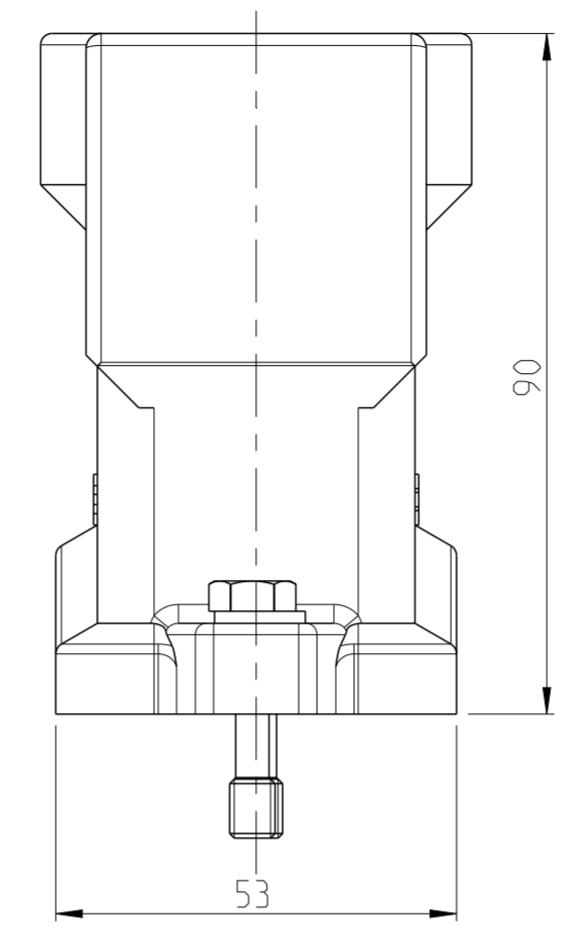
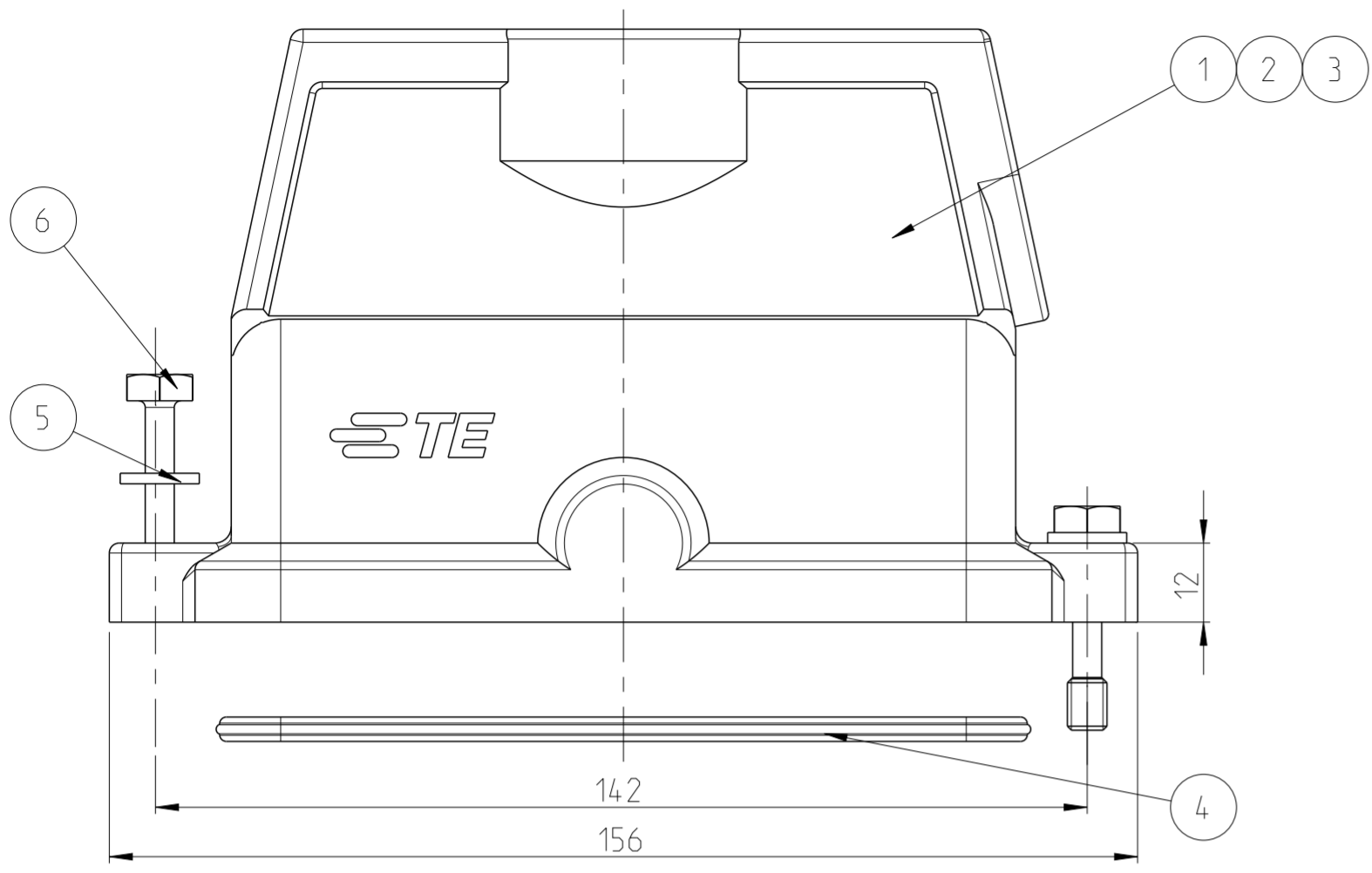

NOTES

- 1 SUITABLE HOUSINGS:  
CUSTOMER DRAWING: 1102665, 1102626, 1102628, 1108533, 1102624, 1102625, 1106472
- 2 STANDARDS:  
DIN EN 61984, DIN EN 60664-1
- 3 TOOL:  
HEXAGONAL DRIVE SIZE 10
- 4 VARNISH ON INSIDE AREA NOT NECESSARY
- 5 PACKAGING: 5 PIECES IN A CARTON BOX
- 6 KEY CHARACTERISTICS PER TEC- 407-55

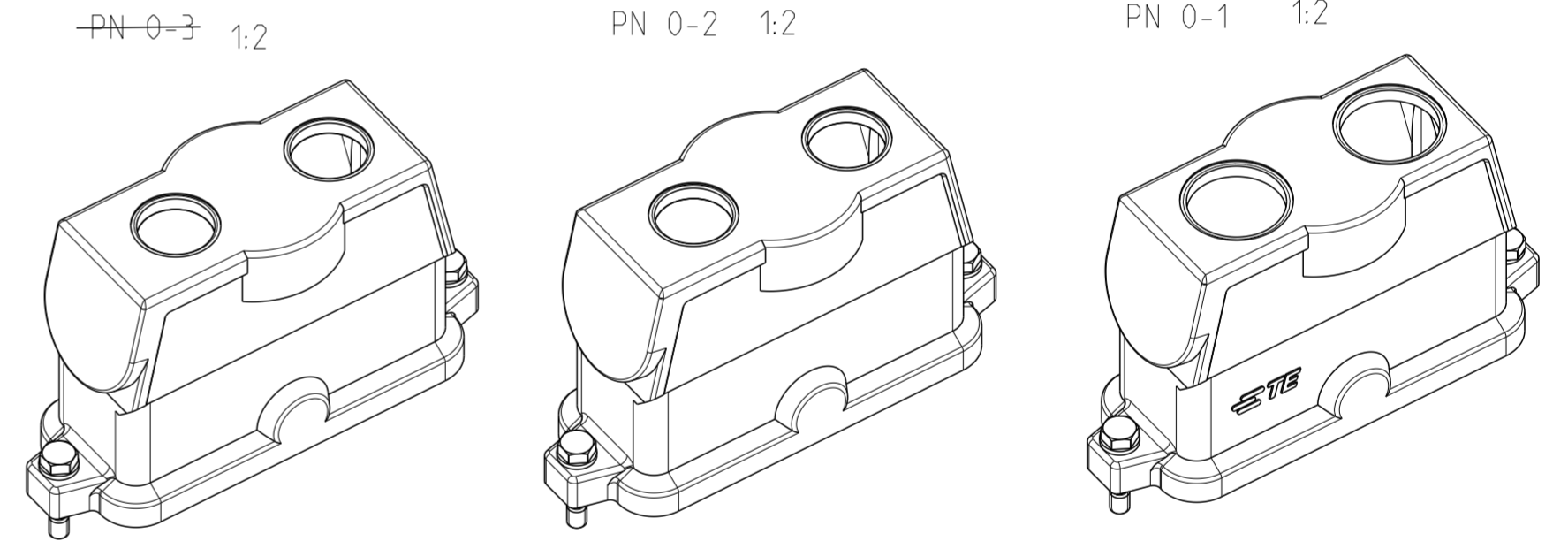

QTY	PN/QTY	DESCRIPTION	MATERIAL	COLOR/SURFACE	NOTE	ITEM
2	2	SCREW, HEXAGONAL BOLT	STAINL. STEEL	BLANK	M6x30, DIN 7964, RED. SHUNK	6
2	2	WASHER, PLAIN	STAINL. STEEL	BLANK	B6, EN ISO 7089, 200 HV	5
1	1	PROFILE SEAL	NEOPRENE	BLACK	SIZE 8	4
1	-	CONNECTOR HOUSING	ALU	BLACK	SIZE 8, THREAD M25	3
1	1	CONNECTOR HOUSING	ALU	BLACK	SIZE 8, THREAD M25, WITHOUT LOGO	2
1	-	CONNECTOR HOUSING	ALU	BLACK	SIZE 8, THREAD M32	1
0-3	0-2	0-1				

THIS DRAWING IS A CONTROLLED DOCUMENT.

DIMENSIONS: mm

TOLERANCES UNLESS OTHERWISE SPECIFIED:

0 PLC	±
1 PLC	±
2 PLC	±
3 PLC	±
4 PLC	±
ANGLES	±°
FINISH	-

MATERIAL: material\_2

finish\_spec\_2

APVD: H. BRAUN

CHK: G. WROBLEWSKI

DWN: V. GLUMM

11FEB2010

11FEB2010

11FEB2010

STE TE Connectivity

CONNECTOR HOUSING ASSY  
SERIES HIP-K.24/64, SIZE 8, STO

SIZE: A2

CAGE CODE: 00779

DRAWING NO: C-1102792

RESTRICTED TO

CUSTOMER DRAWING

SCALE: 5:1

SHEET: 1 OF 1

REV: A7