

### Ceramic Disc Capacitors for Safety Regulations

Type: **GL**

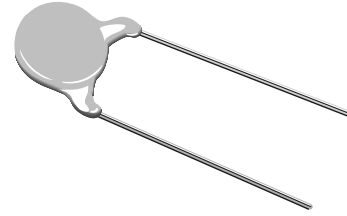

#### ■ Features

Ceramic disc capacitors, "Type GL," rated 250 VAC, are recognized by UL.

(Recognized type designation: Type GL).

#### ■ Recommended Applications

- Line bypass and across-the-line
- Switching surge killer, etc.

#### ■ Explanation of Part Numbers

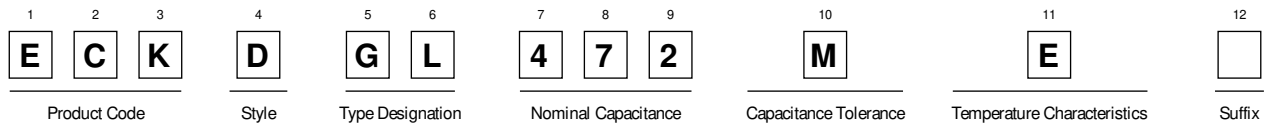

#### ■ Specifications

Operating temperature range	-25 to 85°C		
Rated voltage	<b>Applicable standard</b>		<b>Rated voltage</b>
	UL		250 VAC
	CSA		125 VAC
Dielectric withstanding voltage	1500 VAC (50/60 Hz) for 1 minute		
Capacitance	Within the tolerance, when measured at 1 kHz ± 20%, 1 Vrms and 20°C		
Dissipation factor (tan δ)	B/Y5P/2B4: 0.025 max.; E/Y5U/2E4: 0.025 max., V: 0.05 max.		
Insulation resistance	10,000 MΩ min. at 500 VDC and 1 minute electrification		
Temperature characteristics (Reference temperature: 20°C)	<b>T. C.</b>	<b>Capacitance Change</b>	<b>Temperature Range</b>
	B/Y5P/2B4	±10% max.	-25 to 85°C
	E/Y5U/2E4	+20/-55% max.	-25 to 85°C
	V	+30/-80% max.	0 to 70°C

### ■ Related Standards and Certificate Numbers (Type NS-A)

Related Standards	Certificate Number/File Number
UL 1414	E62674 (Rated 250 VAC)
CSA C22.2	LR58064-7 (Rated 125 VAC)

### ■ Dimensions in mm (not to scale)

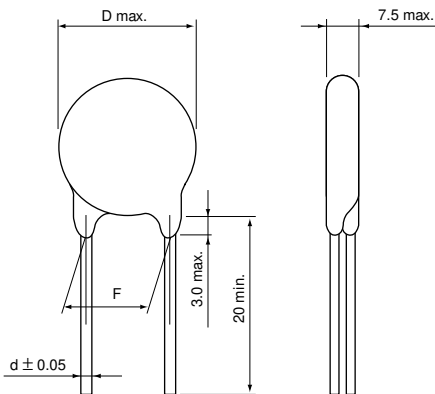

### ■ Typical Temperature Characteristics

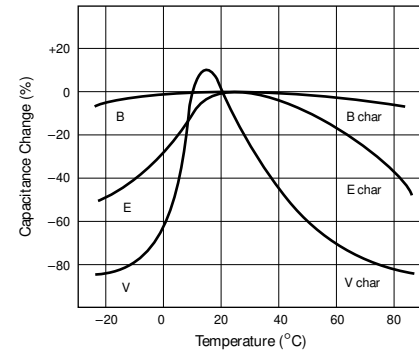

### ■ Ratings and Characteristics

Part Number	Nominal Capacitance (pF)	Tolerance (%)	Temperature Characteristics	Dimensions in mm			
				D max.	T max.	F	d
ECKDGL101MB	100	±20	B	8.0	5.5	7.5±1.5	0.65
ECKDGL151MB	150	— 20	B	8.0	5.5	7.5±1.5	0.65
CKDGL221MB	220	— 20	B	8.0	5.5	7.5±1.5	0.65
CKDGL331MB	330	— 20	B	8.0	5.5	7.5±1.5	0.65
CKDGL471MB	470	— 20	B	9.0	5.5	7.5±1.5	0.65
CKDGL681MB	680	— 20	B	9.0	5.5	7.5±1.5	0.65
CKDGL102MB	1000	— 20	E	9.0	5.5	7.5±1.5	0.65
CKDGL152MB	1500	— 20	E	11.0	5.5	7.5±1.5	0.65
CKDGL222MB	2200	— 20	E	12.0	5.5	7.5±1.5	0.65
CKDGL332MB	3300	— 20	E	15.0	5.5	10.0±1.5	0.65
CKDGL472MB	4700	— 20	E	17.0	5.5	10.0±1.5	0.65
CKDGL472ZV	4700	+80, -20	V	12.0	5.5	7.5±1.5	0.65
CKDGL103ZV	10000	+80, -20	V	17.0	5.5	10.0±1.5	0.65

Note: Radial taped versions are available on request.