

Evaluation Board for the **ADP5090** Ultralow Power Boost Regulator

GENERAL DESCRIPTION

The **ADP5090** is an ultralow, power synchronous, dc-to-dc boost regulator in a compact 3 mm × 3 mm LFCSP_WQ package. The **ADP5090** runs from input voltages of 0.38 V to 3.3 V and requires minimal external components to provide a high efficiency solution with an integrated power switch, a synchronous rectifier, and battery management.

The **EVAL-ADP5090** evaluation board provides an easy way to evaluate the device. This user guide describes how to quickly set up the board and deliver up to 3.5 V maximum voltage to the

SYS output using an external resistor divide. The internal switches turn on if the storage element voltage at the BAT pin is above the externally programmed SETSD voltage of 2.4 V. The PGOOD indicator toggles high when the SYS pin ramps up to 3 V.

Complete information about the **ADP5090** is available in the corresponding data sheet. Consult the data sheet in conjunction with this user guide when using the evaluation board.

THE **EVAL-ADP5090** EVALUATION BOARD

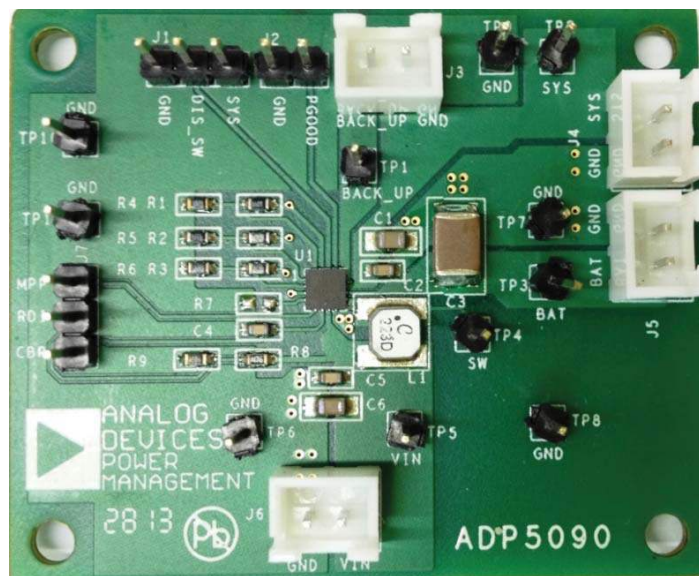

Figure 1. Photograph of the **EVAL-ADP5090** Evaluation Board

TABLE OF CONTENTS

General Description	1	Measuring the EVAL-ADP5090 Performance	4
The EVAL-ADP5090 Evaluation Board	1	Evaluation Board Schematics.....	6
Revision History	2	Evaluation Board Layout	7
Setting Up the Evaluation Board	3	Ordering Information.....	8
Powering Up the Evaluation Board.....	3	Bill of Materials.....	8

REVISION HISTORY

9/14—Revision 0: Initial Version

SETTING UP THE EVALUATION BOARD

POWERING UP THE EVALUATION BOARD

The [ADP5090](#) evaluation board is fully assembled and tested. Use the following setup procedures before applying power to the evaluation board,

Jumper Settings

Table 1 describes the jumper settings.

Table 1. Jumper Settings

Jumper	State or Connection	Function
J1 (DIS_SW)	SYS GND	Disables the main boost Enables the main boost
J2 (PGOOD)	Not applicable	Pull high when the SYS voltage ramps up to preset the SETPG rising threshold
J3 (RDIV)	MPPT Floating	With MPPT sensing function Without MPPT sensing function; provide an external voltage at the CBP pin as the MPPT voltage

Input Power Source Connection

Energy harvesting power sources are high impedance sources. As Figure 2 shows, a source meter configured as a current source with a voltage limit set to the open circuit voltage of the harvester is the best way to simulate the harvester. For a low output impedance power supply (voltage source), it is necessary to simulate the impedance of the harvester with a physical resistor, R, between the supply and the VIN pin. If the input current source includes a voltage meter, use the meter to monitor the input voltage as follows:

1. Connect the positive terminal of the power source to the VIN terminal (J6) on the evaluation board.
2. Connect the negative terminal of the power source to the GND terminal (J6) on the evaluation board.

If the input power supply does not include a current meter, connect a current meter in series with the input power supply as follows:

1. Connect the external series resistor of the power source to the positive terminal (+) of the current meter.
2. Connect the negative terminal of the power source to the GND terminal (J6) on the evaluation board.
3. Connect the negative terminal (-) of the current meter to the VIN terminal (J6) on the evaluation board.

Output Load Connection

Before connecting the load to the [EVAL-ADP5090](#) evaluation board, ensure that the SYS voltage is higher than the end of the cold-startup threshold (V_{SYS_TH} , 1.93 V typical), or that the PGOOD signal is high. If the load includes a current meter or if the current is not measured, connect the load directly to the evaluation board as follows:

1. Connect the positive load connection (+) to the SYS terminal (J4) on the evaluation board.
2. Connect the negative load connection (-) to the GND terminal (J4) on the evaluation board.

If a current meter is used, connect it in series with the load as follows:

1. Connect the positive terminal (+) of the current meter to the SYS terminal (J4) on the evaluation board.
2. Connect the negative terminal (-) of the current meter to the positive terminal (+) of the load.
3. Connect the negative terminal (-) of the load to the GND terminal (J4) on the evaluation board.

Storage Elements Connection

The [EVAL-ADP5090](#) can charge some types of energy storage elements, such as rechargeable batteries, super capacitors, and conventional capacitors. In general, the storage elements maintain constant power or peak power of the system that cannot directly come from the input source. It is necessary to consider any significant leakage current of batteries and super capacitors. For applications information, refer to the [ADP5090](#) data sheet.

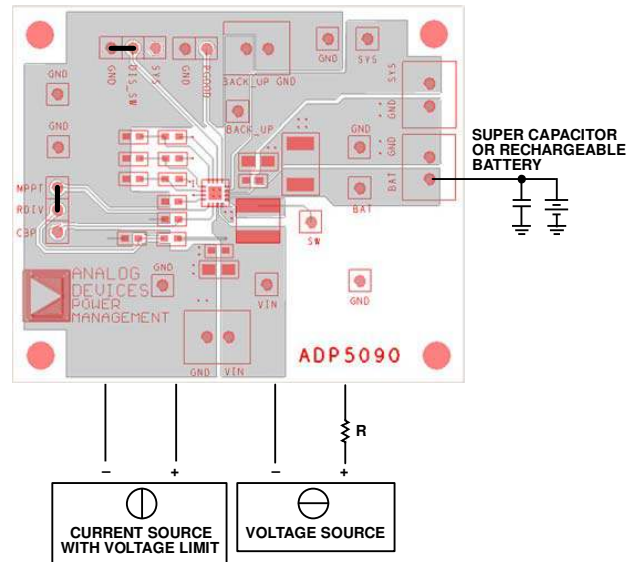

Figure 2. Setup for the [EVAL-ADP5090](#) Evaluation Board

Input and Output Voltmeter Connections

Measure the input and output voltages with voltmeters. Ensure that the voltmeters connect to the appropriate test points on the board. If the voltmeters are not connected to the correct test points, the measured voltages may be incorrect due to the voltage drop across the leads, or due to the connections between the board, the power source, and/or the load. To connect the voltmeters, use the following procedure:

1. Connect the positive terminal (+) of the input voltage measuring voltmeter to Test Point TP5 on the evaluation board.
2. Connect the negative terminal (–) of the input voltage measuring voltmeter to Test Point TP6 on the board.
3. Connect the positive terminal (+) of the output voltage measuring voltmeter to Test Point TP2 on the board.
4. Connect the negative terminal (–) of the output voltage measuring voltmeter to Test Point TP9 on the board.

Powering On the Evaluation Board

If the open circuit voltage (OCV) of the input current source is above a minimum input voltage of 0.38 V for cold-start (typical), and the input power is above the 16 μ W minimum input power of cold-start (typical), the [EVAL-ADP5090](#) enters cold-startup when the SYS voltage is below V_{SYS_TH} . When the SYS voltage is above V_{SYS_TH} , the board exits cold-startup and enables the main boost.

After cold-startup, the MPPT sampling circuit is active and the harvester OCV is detectable because there is no input current to create a droop across the impedance. The main boost runs and draws current until the VIN voltage drops to the sampled MPPT voltage stored at the CBP pin.

Optional BACK_UP Setup

An optional primary battery connected to the BACK_UP pin can accelerate the cold-startup or maintain the system load. When the voltage at the BACK_UP pin is higher than the voltage at the BAT pin, the [ADP5090](#) turns on the internal power MOSFETs between the BACK_UP pin and the SYS pin. When the BACK_UP pin voltage is lower than the BAT pin voltage, the internal power MOSFETs turn off.

MEASURING THE [EVAL-ADP5090](#) PERFORMANCE

Measuring the Switching Waveform

To observe the switching waveform with an oscilloscope, place the oscilloscope probe tip at Test Point TP4 with the probe ground connected to the GND pin. Set the oscilloscope to a dc coupling, 2 V/division, 10 μ sec/division time base. The switching waveform alternates between 0 V and the approximate SYS voltage.

Measuring Efficiency

Measure the efficiency, η , by comparing the input power with the output power. Figure 3 shows the test setup. Float the RDIV jumper (J3) and provide an external voltage at the CBP pin as the MPPT voltage so that the input voltage is regulated to this voltage. With a voltage source meter capable of sinking current to connect to the SYS pin, obtain the output voltage and output current.

$$\eta = \frac{V_{SYS} \times I_{SYS}}{V_{IN} \times I_{IN}}$$

Measuring the Inductor Current

Measure the inductor current by removing one end of the inductor from the pad on the board and using a wire connected between the pad and the inductor. Then, use a current probe to measure the inductor current.

Measuring the Output Voltage Ripple

To observe the output voltage ripple, place an oscilloscope probe across Output Capacitor C1 with the probe ground lead placed at the negative capacitor terminal (–) and the probe tip placed at the positive capacitor terminal (+). Set the oscilloscope to an ac coupling, 50 mV/division, 1 sec/division time base and a 20 MHz bandwidth.

A standard oscilloscope probe has a long wire ground clip. For high frequency measurements, this ground clip picks up high frequency noise and injects it into the measured output ripple.

To eliminate the noise injection, remove the oscilloscope probe sheath and wrap a nonshielded wire around the oscilloscope probe. By keeping the ground lengths of the oscilloscope probe as short as possible, the true ripple can be measured.

Output Voltage Change

The output voltage of the EVAL-ADP5090 is preset to 3.5 V. However, the output voltage can be adjusted using the following equation:

$$V_{SYS} = \frac{3}{2} V_{REF} \left(1 + \frac{R3}{R6} \right)$$

To prevent deeply discharging storage elements at the BAT pin, the voltage threshold can be programmed using the following equation:

$$V_{SETSD} = V_{REF} \left(1 + \frac{R2}{R5} \right)$$

where V_{REF} , the typical internal reference voltage, is 1.21 V.

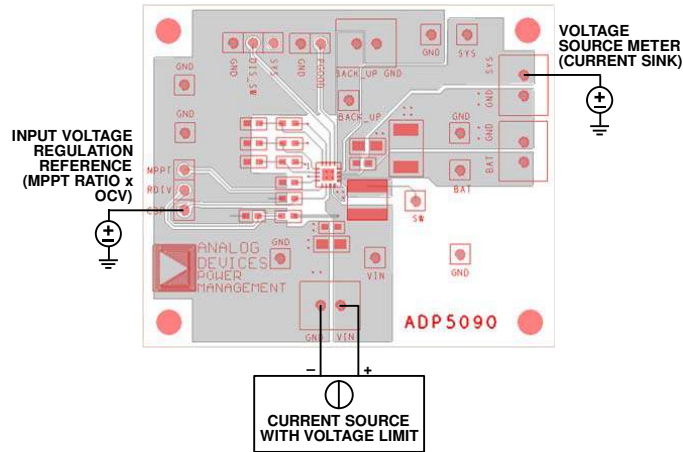

Figure 3. Test Setup for Measuring the Efficiency of the EVAL-ADP5090

12384-003

EVALUATION BOARD SCHEMATICS

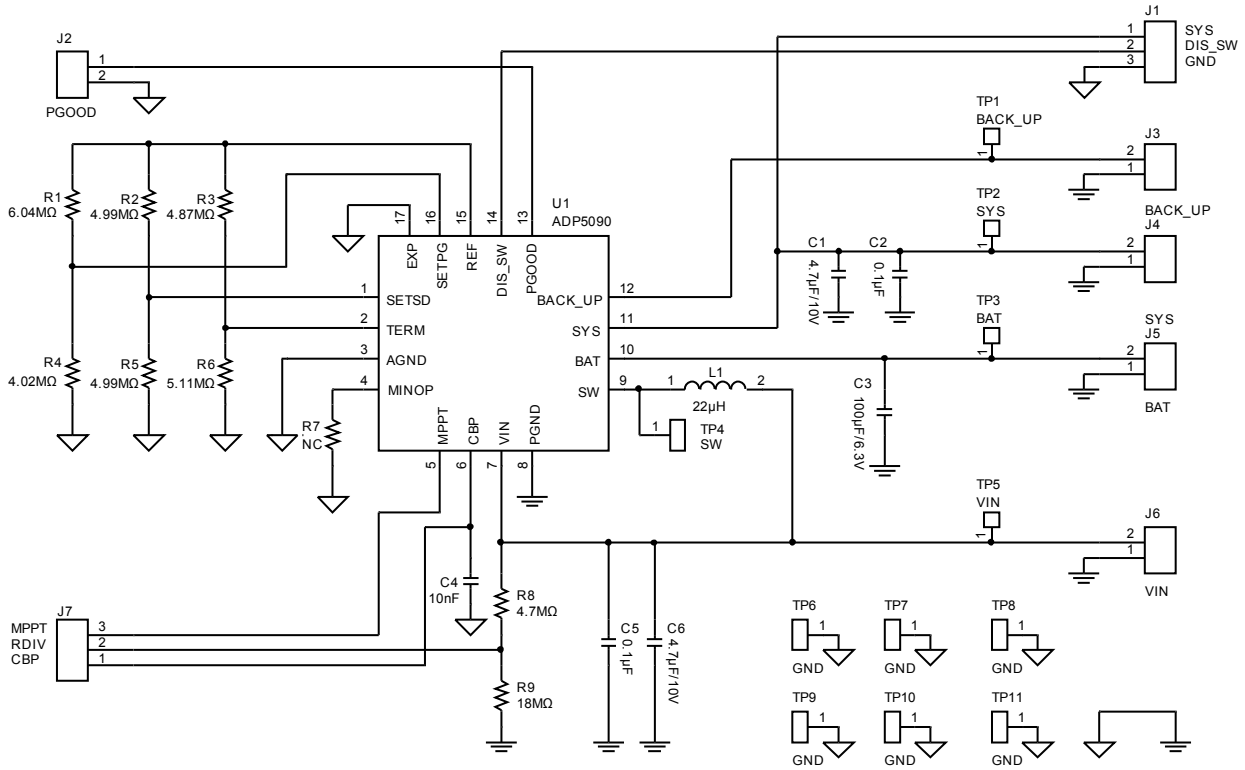

Figure 4. Schematic of the EVAL-ADP5090

12394-004

EVALUATION BOARD LAYOUT

Figure 5 and Figure 6 show the top and bottom layers of the EVAL-ADP5090.

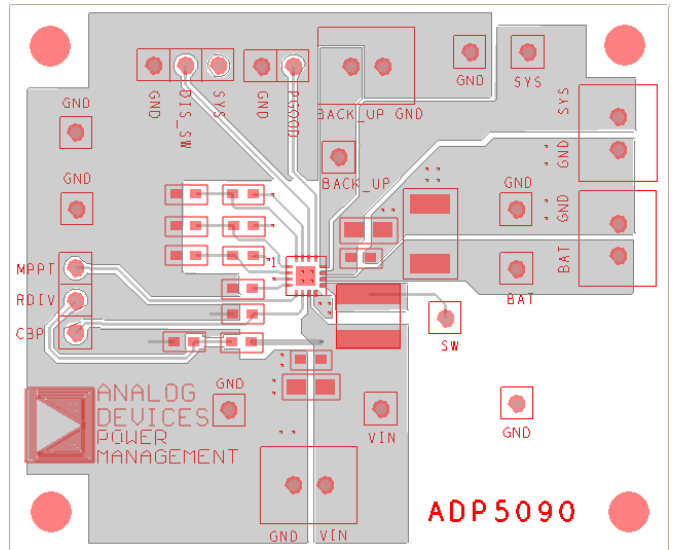

Figure 5. EVAL-ADP5090, Top Layer

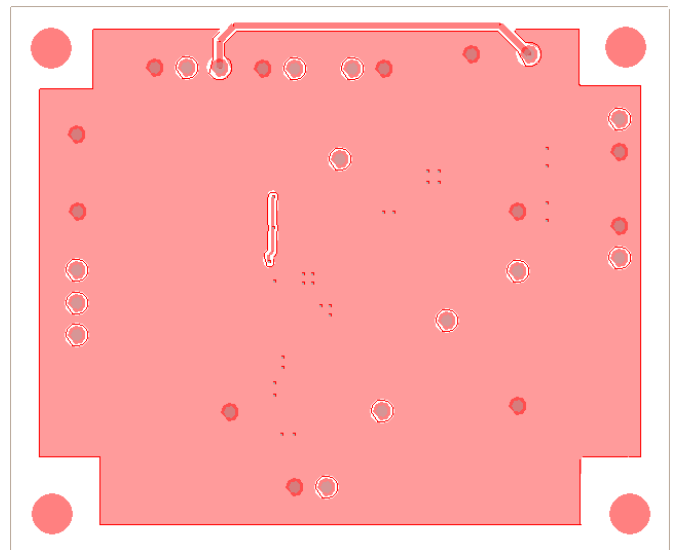

Figure 6. EVAL-ADP5090, Bottom Layer

ORDERING INFORMATION

BILL OF MATERIALS

Table 2. The **ADP5090** Evaluation Board Bill of Materials

Quantity	Reference Designator	Description	Part Number	PCB Footprint	Vendor
2	C1, C6	Capacitor, 4.7 μ F, 10 V	GRM21BR61A475KA73	C0805	Murata
2	C2, C5	Capacitor, 0.1 μ F	GRM188R71H104KA93	C0603	Murata
1	C3	Capacitor, 100 μ F, 6.3 V	C4532X5R0J107M280KA	C1812	TDK
1	C4	Capacitor, 10 nF	GRM188R71H103KA01	C0603	Murata
1	J1	DIS_SW	M20-9990246	SIP3	Harwin
1	J2	PGOOD	M20-9990245	SIP2	Harwin
1	J3	BACK_UP		SIP2_big	Harwin
1	J4	SYS		SIP2_big	Harwin
1	J5	BAT		SIP2_big	Harwin
1	J6	VIN		SIP2_big	Harwin
1	J7	RDIV	M20-9990246	SIP3	Harwin
1	L1	Inductor, 22 μ H	LPS4018-223MLB	Inductor_4x4	Coilcraft
		Inductor, 22 μ H	74437324220	Inductor_4x4	Wurth
1	R1	Resistor, 6.04 M Ω	CRCW06036M04FKTA	R0603	Vishay Dale
2	R2, R5	Resistor, 4.99 M Ω	CRCW06034M99FKEA	R0603	Vishay Dale
1	R3	Resistor, 4.87 M Ω	CRCW06034M87FKEA	R0603	Vishay Dale
1	R4	Resistor, 4.02 M Ω	CRCW06034M02FKEA	R0603	Vishay Dale
1	R6	Resistor, 5.11 M Ω	CRCW06035M11FKEA	R0603	Vishay Dale
1	R7	Resistor, 20k	CRCW060320K0FKEA	R0603	Vishay Dale
1	R8	Resistor, 4.7 M Ω	CRCW06034M70FKEA	R0603	Vishay Dale
1	R9	Resistor, 18 M Ω	RK73B1JTDD186J	R0603	KOA
1	TP1	BACK_UP	M20-9990245	SIP1	Harwin
1	TP2	SYS	M20-9990245	SIP1	Harwin
1	TP3	BAT	M20-9990245	SIP1	Harwin
1	TP4	SW	M20-9990245	SIP1	Harwin
1	TP5	VIN	M20-9990245	SIP1	Harwin
6	TP6, TP7, TP8, TP9, TP10, TP11	GND	M20-9990245	SIP1	Harwin
1	U1	IC	ADP5090ACPZ-1-R7	LFCSP16-3x3PL	Analog Devices



ESD Caution

ESD (electrostatic discharge) sensitive device. Charged devices and circuit boards can discharge without detection. Although this product features patented or proprietary protection circuitry, damage may occur on devices subjected to high energy ESD. Therefore, proper ESD precautions should be taken to avoid performance degradation or loss of functionality.

Legal Terms and Conditions

By using the evaluation board discussed herein (together with any tools, components documentation or support materials, the "Evaluation Board"), you are agreeing to be bound by the terms and conditions set forth below ("Agreement") unless you have purchased the Evaluation Board, in which case the Analog Devices Standard Terms and Conditions of Sale shall govern. Do not use the Evaluation Board until you have read and agreed to the Agreement. Your use of the Evaluation Board shall signify your acceptance of the Agreement. This Agreement is made by and between you ("Customer") and Analog Devices, Inc. ("ADI"), with its principal place of business at One Technology Way, Norwood, MA 02062, USA. Subject to the terms and conditions of the Agreement, ADI hereby grants to Customer a free, limited, personal, temporary, non-exclusive, non-sublicensable, non-transferable license to use the Evaluation Board FOR EVALUATION PURPOSES ONLY. Customer understands and agrees that the Evaluation Board is provided for the sole and exclusive purpose referenced above, and agrees not to use the Evaluation Board for any other purpose. Furthermore, the license granted is expressly made subject to the following additional limitations: Customer shall not (i) rent, lease, display, sell, transfer, assign, sublicense, or distribute the Evaluation Board; and (ii) permit any Third Party to access the Evaluation Board. As used herein, the term "Third Party" includes any entity other than ADI, Customer, their employees, affiliates and in-house consultants. The Evaluation Board is NOT sold to Customer; all rights not expressly granted herein, including ownership of the Evaluation Board, are reserved by ADI. CONFIDENTIALITY. This Agreement and the Evaluation Board shall all be considered the confidential and proprietary information of ADI. Customer may not disclose or transfer any portion of the Evaluation Board to any other party for any reason. Upon discontinuation of use of the Evaluation Board or termination of this Agreement, Customer agrees to promptly return the Evaluation Board to ADI. ADDITIONAL RESTRICTIONS. Customer may not disassemble, decompile or reverse engineer chips on the Evaluation Board. Customer shall inform ADI of any occurred damages or any modifications or alterations it makes to the Evaluation Board, including but not limited to soldering or any other activity that affects the material content of the Evaluation Board. Modifications to the Evaluation Board must comply with applicable law, including but not limited to the RoHS Directive. TERMINATION. ADI may terminate this Agreement at any time upon giving written notice to Customer. Customer agrees to return to ADI the Evaluation Board at that time. LIMITATION OF LIABILITY. THE EVALUATION BOARD PROVIDED HEREUNDER IS PROVIDED "AS IS" AND ADI MAKES NO WARRANTIES OR REPRESENTATIONS OF ANY KIND WITH RESPECT TO IT. ADI SPECIFICALLY DISCLAIMS ANY REPRESENTATIONS, ENDORSEMENTS, GUARANTEES, OR WARRANTIES, EXPRESS OR IMPLIED, RELATED TO THE EVALUATION BOARD INCLUDING, BUT NOT LIMITED TO, THE IMPLIED WARRANTY OF MERCHANTABILITY, TITLE, FITNESS FOR A PARTICULAR PURPOSE OR NON-INFRINGEMENT OF INTELLECTUAL PROPERTY RIGHTS. IN NO EVENT WILL ADI AND ITS LICENSORS BE LIABLE FOR ANY INCIDENTAL, SPECIAL, INDIRECT, OR CONSEQUENTIAL DAMAGES RESULTING FROM CUSTOMER'S POSSESSION OR USE OF THE EVALUATION BOARD, INCLUDING BUT NOT LIMITED TO LOST PROFITS, DELAY COSTS, LABOR COSTS OR LOSS OF GOODWILL. ADI'S TOTAL LIABILITY FROM ANY AND ALL CAUSES SHALL BE LIMITED TO THE AMOUNT OF ONE HUNDRED US DOLLARS (\$100.00). EXPORT. Customer agrees that it will not directly or indirectly export the Evaluation Board to another country, and that it will comply with all applicable United States federal laws and regulations relating to exports. GOVERNING LAW. This Agreement shall be governed by and construed in accordance with the substantive laws of the Commonwealth of Massachusetts (excluding conflict of law rules). Any legal action regarding this Agreement will be heard in the state or federal courts having jurisdiction in Suffolk County, Massachusetts, and Customer hereby submits to the personal jurisdiction and venue of such courts. The United Nations Convention on Contracts for the International Sale of Goods shall not apply to this Agreement and is expressly disclaimed.