



# PRODUCT SPECIFICATION

## LOW PROFILE RIGHT ANGLE MODULAR JACKS

### 1.0 SCOPE

This Product Specification covers the 1.27 mm (.050 inch) centerline (pitch) printed circuit board (PCB) modular jack connector series with selective gold and tin plating.

### 2.0 PRODUCT DESCRIPTION

#### 2.1 PRODUCT NAME AND SERIES NUMBER(S)

Low Profile Right Angle Modular Jacks 43223

#### 2.2 DIMENSIONS, MATERIALS, PLATINGS AND MARKINGS

See the appropriate sales drawings (SDA-43223) for information on dimensions, materials, plating and markings.

#### 2.3 SAFETY AGENCY APPROVALS

UL File Number.....E107635  
CSA File Number.....LR19980

### 3.0 REFERENCE DOCUMENTS

FCC Rules and Regulations, Part 68, Subpart F  
REA Bulletin 345-81, PE-76; Specification for modular telephone set hardware  
ANSI/EIA/TIA-568  
IEC-60603-7  
UL 1863  
MIL-STD-202; General requirements for test specifications

### 4.0 RATINGS

#### 4.1 VOLTAGE

56.5 V DC  
150 V<sub>RMS</sub> AC (Ringing voltage only)

#### 4.2 CURRENT

1.5 Amps @ 25°C

#### 4.3 TEMPERATURE

Operating: - 40°C to + 85°C  
Nonoperating:\* - 40°C to + 85°C  
\*Packaging materials should not exceed + 50°C

REVISION: <b>C1</b>	EGR/ECN INFORMATION: EC No: <b>UCP2008-0143</b> DATE: <b>8/3/2007</b>	TITLE: <b>PRODUCT SPECIFICATION LOW PROFILE RIGHT ANGLE MODULAR JACKS</b>	SHEET No. <b>1 of 5</b>
DOCUMENT NUMBER: <b>PS-43223-001</b>	CREATED / REVISED BY: <b>JBELL 7/23/2007</b>	CHECKED BY: <b>LSCHMIDT 7/24/2007</b>	APPROVED BY: <b>FSMITH 7/25/2007</b>



# PRODUCT SPECIFICATION

## 5.0 PERFORMANCE

### 5.1 ELECTRICAL REQUIREMENTS

	DESCRIPTION	TEST CONDITION	REQUIREMENT
	<b>Contact Resistance (Low Level)</b>	Mate connectors: apply a maximum voltage of <b>20 mV</b> and a current of <b>15 mA</b> . (Measurement locations in Section 7.0)	<b>10 milliohms</b> MAXIMUM [initial]
	<b>Insulation Resistance</b>	Unmated connector, mounted to a PCB: apply a voltage of <b>500 VDC</b> between adjacent terminals and between terminals to ground.	<b>500 Megohms</b> MINIMUM
	<b>Dielectric Withstanding Voltage</b>	Mate connectors: apply a voltage of <b>1000 VAC</b> for <b>1</b> minute between adjacent terminals and between terminals to ground.	No breakdown; current leakage < <b>5 mA</b>
	<b>Temperature Rise</b>	Mate connectors: measure the temperature rise at the rated current after: <b>96</b> hours	Temperature rise; <b>+30°C</b> MAXIMUM

REVISION: <b>C1</b>	EGR/ECN INFORMATION: EC No: <b>UCP2008-0143</b> DATE: <b>8/3/2007</b>	TITLE: <b>PRODUCT SPECIFICATION LOW PROFILE RIGHT ANGLE MODULAR JACKS</b>	SHEET No. <b>2 of 5</b>
DOCUMENT NUMBER: <b>PS-43223-001</b>	CREATED / REVISED BY: <b>JBELL 7/23/2007</b>	CHECKED BY: <b>LSCHMIDT 7/24/2007</b>	APPROVED BY: <b>FSMITH 7/25/2007</b>



# PRODUCT SPECIFICATION

## 5.2 MECHANICAL REQUIREMENTS

	DESCRIPTION	TEST CONDITION	REQUIREMENT
	<b>Connector Mate Force</b>	Mate connector at a rate of <b>25 ± 6 mm (1 ± ¼ inch)</b> per minute. (Gage dimensions in Section 7.0)	<b>22 N (5 lbf)</b> MAXIMUM insertion force
	<b>Durability</b>	Mate connectors up to <b>500</b> cycles at a maximum rate of <b>20</b> cycles per minute prior to Environmental Tests.	<b>10</b> milliohms MAXIMUM (change from initial)
	<b>Vibration (Random)</b>	Mate connectors and vibrate per MIL-STD-202	<b>10</b> milliohms MAXIMUM (change from initial) & Discontinuity < <b>1</b> microsecond
	<b>Plug Retention Force</b>	Apply an axial pullout force on the plug at a rate of <b>25 ± 6 mm (1 ± ¼ inch)</b> per minute.	<b>89 N (20 lbf)</b> MINIMUM retention force
	<b>PCB Separation Forces</b>	Apply a perpendicular load on the plug at a rate of <b>25 ± 6 mm (1 ± ¼ inch)</b> per minute.	<b>4.5 N (1 lbf)</b> MINIMUM withdrawal force before solder reflow <b>89 N (20 lbf)</b> MINIMUM withdrawal force after solder reflow

REVISION: <b>C1</b>	EGR/ECN INFORMATION: EC No: <b>UCP2008-0143</b> DATE: <b>8/3/2007</b>	TITLE: <b>PRODUCT SPECIFICATION LOW PROFILE RIGHT ANGLE MODULAR JACKS</b>	SHEET No. <b>3 of 5</b>
DOCUMENT NUMBER: <b>PS-43223-001</b>	CREATED / REVISED BY: <b>JBELL 7/23/2007</b>	CHECKED BY: <b>LSCHMIDT 7/24/2007</b>	APPROVED BY: <b>FSMITH 7/25/2007</b>



# PRODUCT SPECIFICATION

## 5.3 ENVIRONMENTAL REQUIREMENTS

	DESCRIPTION	TEST CONDITION	REQUIREMENT												
	<b>Thermal (Cycling)</b>	Connectors to be placed in <b>95%</b> relative humidity. Maximum temperature change is <b>15°C/hour</b> . Cycle linearly per chart below. Mate connectors; expose to <b>10</b> cycles of: <table border="1"> <thead> <tr> <th>Temperature °C</th> <th>Duration (Minutes)</th> </tr> </thead> <tbody> <tr> <td><b>30 to 5</b></td> <td><b>120</b></td> </tr> <tr> <td><b>5 to 30</b></td> <td><b>120</b></td> </tr> <tr> <td><b>Hold at 30</b></td> <td><b>240</b></td> </tr> <tr> <td><b>30 to 5</b></td> <td><b>180</b></td> </tr> <tr> <td><b>Hold at 5</b></td> <td><b>180</b></td> </tr> </tbody> </table>	Temperature °C	Duration (Minutes)	<b>30 to 5</b>	<b>120</b>	<b>5 to 30</b>	<b>120</b>	<b>Hold at 30</b>	<b>240</b>	<b>30 to 5</b>	<b>180</b>	<b>Hold at 5</b>	<b>180</b>	<b>10</b> milliohms MAXIMUM (change from initial) & Dielectric Withstanding Voltage: No Breakdown at <b>500 VAC</b> & Insulation Resistance: <b>500</b> Megohms MINIMUM & Visual: No Damage
Temperature °C	Duration (Minutes)														
<b>30 to 5</b>	<b>120</b>														
<b>5 to 30</b>	<b>120</b>														
<b>Hold at 30</b>	<b>240</b>														
<b>30 to 5</b>	<b>180</b>														
<b>Hold at 5</b>	<b>180</b>														
	<b>Solderability</b>	Dip solder tails in flux and immerse in solder Bath at <b>260±5°C</b> for <b>5±0.5</b> seconds	Solder Wetting Visual: <b>95%</b> of immersed area must show no voids, pin holes												

REVISION: <b>C1</b>	EGR/ECN INFORMATION: EC No: <b>UCP2008-0143</b> DATE: <b>8/3/2007</b>	TITLE: <b>PRODUCT SPECIFICATION LOW PROFILE RIGHT ANGLE MODULAR JACKS</b>	SHEET No. <b>4 of 5</b>
DOCUMENT NUMBER: <b>PS-43223-001</b>	CREATED / REVISED BY: <b>JBELL 7/23/2007</b>	CHECKED BY: <b>LSCHMIDT 7/24/2007</b>	APPROVED BY: <b>FSMITH 7/25/2007</b>



# PRODUCT SPECIFICATION

## 6.0 PACKAGING

Parts shall be packaged to protect against damage during handling, transit and storage. See appropriate sales drawings on Sheet 1 for packaging descriptions.

## 7.0 GAGES AND FIXTURES

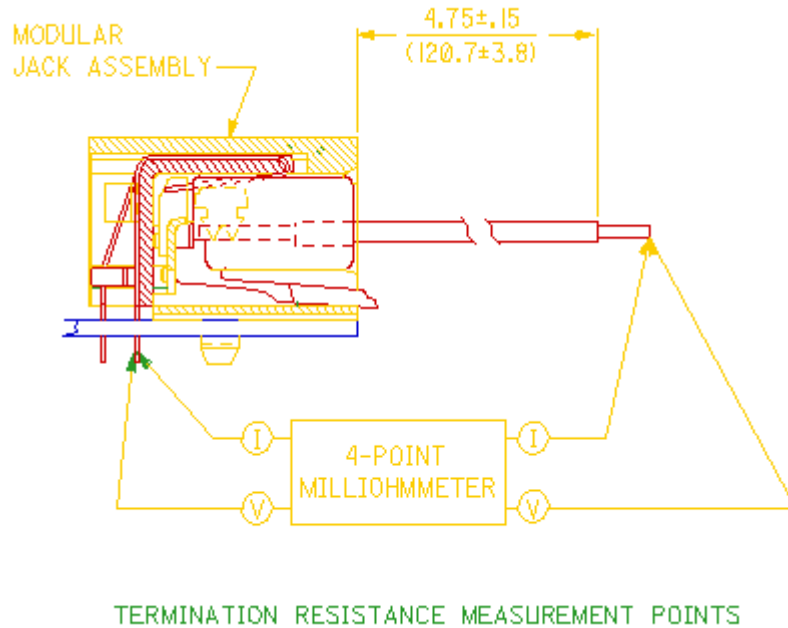

## 8.0 OTHER INFORMATION

REVISION: <b>C1</b>	EGR/ECN INFORMATION: EC No: <b>UCP2008-0143</b> DATE: <b>8/3/2007</b>	TITLE: <b>PRODUCT SPECIFICATION LOW PROFILE RIGHT ANGLE MODULAR JACKS</b>	SHEET No. <b>5 of 5</b>
DOCUMENT NUMBER: <b>PS-43223-001</b>	CREATED / REVISED BY: <b>JBELL 7/23/2007</b>	CHECKED BY: <b>LSCHMIDT 7/24/2007</b>	APPROVED BY: <b>FSMITH 7/25/2007</b>