

PRODUCT NO
SEE TABLE

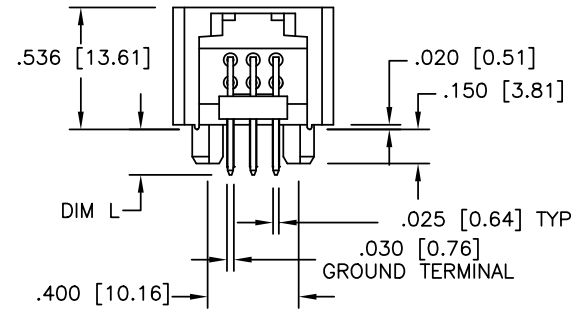
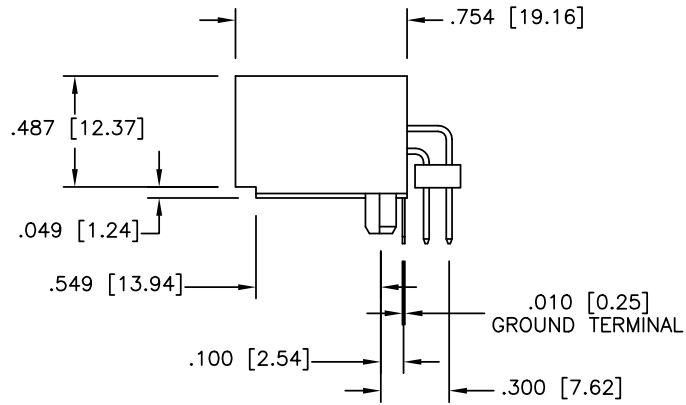
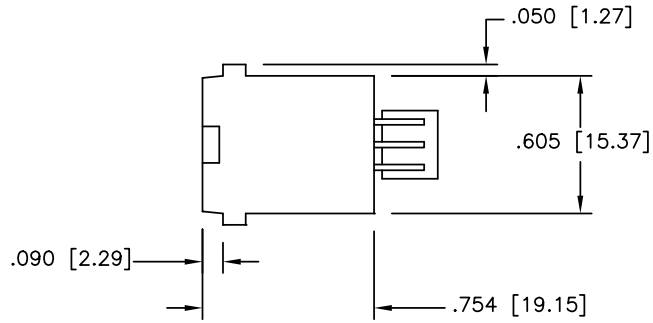

mat'l. code		surface ISO 1302 ✓		tolerance ISO 406 ISO 1101		projection ⊕		product family LATCH-N-LOK	
ltr ecn nodr date		tolerances unless otherwise specified		title		INCH/MM		2X3 LNL LOW PROFILE HEADER ASSEMBLY	
C	V00432	TFG	2/22/00	angles	linea	.XX±.01/0.X±0.3		dwg no	
D	V01703	TFG	7/21/00	0°±2'		.XXX±.005/0.XXX±0.13		sheet 1 of 2	
E	V10987	TFG	2/27/01			.XXX±.0020/0.XXX±0.05		size	
F	M05-0050	MHT	3/16/05	dr	N. CORNMANN	6/25/90		A3	
G	M06-0365	AGS	9/20/06	engr	D. HORCHLER	6/25/90		78097	
H	M09-0048	MHT	3/12/09	chr	D. HORCHLER	6/25/90		type Product Customer Drawing	
J	BL-N-00452	ZK	11/28/11	app	D. HORCHLER	6/25/90			
sheet	revision	J	J						
index	sheet	1	2						

FCI
FCIconnect.com
Copyright FCI

78097-XXXLF

LEAD FREE OPTION (6) (7)

COLOR (4)		
1	70343 LF GRAY	OBS
2	80166 OFF WHITE	
3	70634 DK GRAY	OBS
4	701 BLACK	
5	70514 SLATE GRAY	OBS
7	70455 SILVER GRAY	
8	80189 PEARL WHITE	OBS
9	70419 PEBBLE GRAY	

PLATING (3)	
0	30u" MIN OVER 50u"MIN Ni
3	30u" MIN OVER 50u"MIN Ni
5	50u" MIN OVER 50u"MIN Ni

PIN LENGTH	
	DIM L
0	.200/5.08
1	.130/3.30

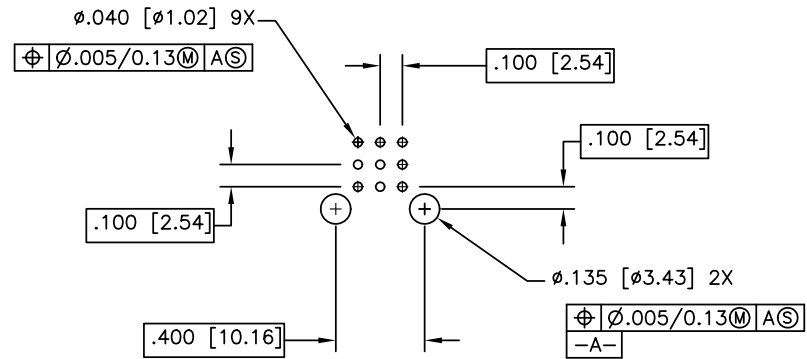

RECOMMENDED PCB LAYOUT

NOTES:

- HEADER SHROUD
MAT'L: HIGH TEMPERATURE THERMOPLASTIC,
UL-94V-0 RATED.
- GROUND CONTACT
MAT'L: COPPER ALLOY
PLATING: 100-160u"/2.54-4.06u TIN.
- SIGNAL CONTACT
MAT'L: COPPER ALLOY
PLATING OPTION: PERFORMANCE PLATING WILL BE EITHER GOLD OR GXT ON CONTACT AREA OR TAIL, OPTIONALLY (78-295u") TIN ON TAIL.
- NUMBERS SHOWN ARE FOR G.E. LEXAN AND ARE FOR REFERENCE ONLY.
- THIS ASSEMBLY U.L. APPROVED PER FILE E66906 VOL. 1, SEC. 84 AND CSA APPROVED PER MASTER FILE LR46923.
- ADD LF SUFFIX AT THE END OF PART NUMBER FOR LEAD FREE OPTION.
- THE HOUSING WILL WITHSTAND EXPOSURE TO 260°C PEAK TEMPERATURE FOR 15 SECONDS IN A WAVE SOLDER APPLICATION WITH A 1.5mm MINIMUM THICK CIRCUIT BOARD. SEE APPLICATION NOTES/PROCEDURES IF THEY ARE AVAILABLE.
- THIS PRODUCT MEETS EUROPEAN UNION DIRECTIVES AND OTHER COUNTRY REGULATION AS DESCRIBED IN GS-22-008.
- PRODUCT SPEC: GS-12-003

mat'l. code		surface ISO 1302 ✓	tolerance ISO 406 ISO 1101	projection ASME Y14.5	product family LATCH-N-LOK
l	tr	ec	n	o	d
date		tolerances unless otherwise specified			title
J		angles	line	INCH/MM	2X3 LNL LOW PROFILE HEADER ASSEMBLY
		0°±2°	XXX±.01/0.X±0.3 XXX±.005/0.XXX±0.13 XXX±.0020/0.XXX±0.05	scale 1:1	
		dr	N. CORNMAN	6/25/90	dwg no
		engr	D. HORCHLER	6/25/90	sheet 2 of 2
		chr	D. HORCHLER	6/25/90	size
		app	D. HORCHLER	6/25/90	78097
					A3
					type Product Customer Drawing
sheet	revision				
index	sheet				