

# FAN7314A — LCD Backlight Inverter Drive IC

## Features

- High-Efficiency Single-Stage Power Conversion
- Wide Input Voltage Range: 6V to 25.5V
- Backlight Lamp Ballast and Soft Dimming
- Minimal Required External Components
- Precision Voltage Reference Trimmed to 2%
- ZVS Half-Bridge Topology
- Soft-Start
- PWM Control at Fixed Frequency
- Analog and Burst Dimming Function
- Programmable Striking Frequency
- Open-Lamp Protection
- Open-Lamp Regulation
- Thermal Shutdown
- 20-Pin SOIC

## Applications

- LCD TV
- LCD Monitor

## Description

The FAN7314A provides all the control functions for a series parallel resonant converter as well as a pulse width modulation (PWM) controller to develop a supply voltage. Typical operating frequency range is between 30kHz and 250kHz, depending on the CCFL and the transformer's characteristics.

The FAN7314A is available in a 20-SOIC package.

**20-SOIC**



## Ordering Information

Part Number	Package	Operating Temperature	 Eco Status	Packing Method
FAN7314AM	20-SOIC	-25 to +85°C	RoHS	RAIL
FAN7314AMX	20-SOIC	-25 to +85°C	RoHS	TAPE & REEL

 For Fairchild's definition of "green" Eco Status, please visit: [http://www.fairchildsemi.com/company/green/rohs\\_green.html](http://www.fairchildsemi.com/company/green/rohs_green.html).

Protected under U.S. patent nos. 5,652,479.

## Important Note:

For complete performance specifications, please contact one of the following:

NA(TX)	Jinho Choi	<a href="mailto:jinho.choi@fairchildsemi.com">jinho.choi@fairchildsemi.com</a>	1-972-447-1316
EU(UK)	Justin Ahn	<a href="mailto:Justin.Ahn@Fairchildsemi.com">Justin.Ahn@Fairchildsemi.com</a>	+44(0)1793-856 828
KR	KI Jeon	<a href="mailto:Kwangil.Jeon@fairchildsemi.co.kr">Kwangil.Jeon@fairchildsemi.co.kr</a>	02-3498-0543
AP(HK)	SH Lee	<a href="mailto:seunghwan.lee@fairchildsemi.com">seunghwan.lee@fairchildsemi.com</a>	852-2722-8372
JP	Yasuhiko Itoh	<a href="mailto:Yasuhiko.Itoh@fairchildsemi.com">Yasuhiko.Itoh@fairchildsemi.com</a>	03-5275-8380

## Typical Application Circuit (LCD Backlight Inverter)

Application	Device	Input Voltage Range	Number of lamps
22-Inch LCD Monitor	FAN7314A	22V±5%	4

### 1. Features

- High-Efficiency Single-Stage Power Conversion
- P-N Half-Bridge Topology
- Reduces Required External Components
- Enhanced System Reliability through Protection Functions

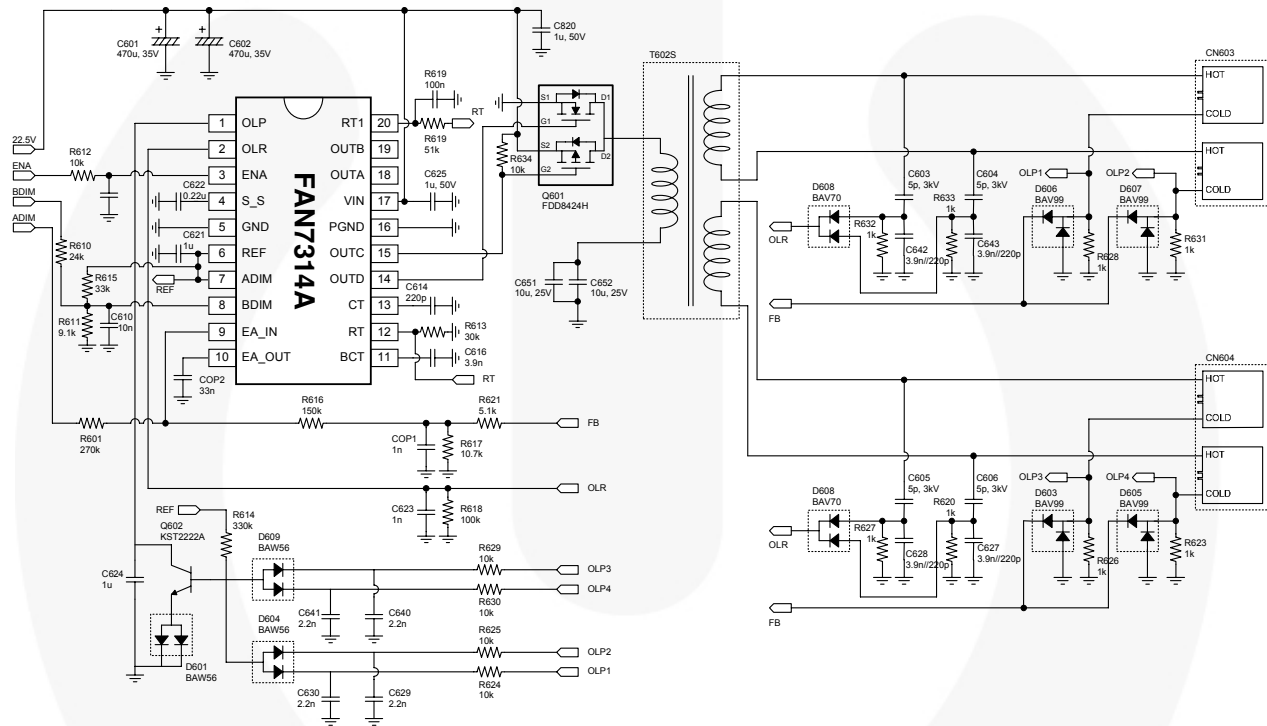

Figure 9. Typical Application Circuit

### 2. Transformer Specifications

- Supported by Clover Hitech (<http://www.cloverhitech.com>)
- PART NO : EEL-22W

Pin No.	Wire	Turns	Inductance	Leakage Inductance	Remarks
2 → 7	UTSC 0.1×12	19	83.0μH	16μH	1kHz, 1V
3 → 6					
1 → 8	1 UEW 0.04Ω	2300	1.4H	280mH	
4 → 5					



**TRADEMARKS**

The following includes registered and unregistered trademarks and service marks, owned by Fairchild Semiconductor and/or its global subsidiaries, and is not intended to be an exhaustive list of all such trademarks.

- |   |                        |   |   |
|---|------------------------|---|---|
| Build it Now™   | FPS™                   | PDP SPM™  | The Power Franchise®  |
| CorePLUSTM  | F-PFS™                 | Power-SPM™  |  |
| CorePOWER™  | FRFET®                 | PowerTrench®  | TinyBoost™  |
| CROSSVOLT™  | Global Power Resource™ | Programmable Active Droop™  | TinyBuck™   |
| CTL™  | Green FPST™            | QFET®   | TinyLogic™  |
| Current Transfer Logic™   | Green FPST™ e-Series™  | QST™  | TINYOPTO™   |
| EcoSPARK®   | GTO™                   | Quiet Series™   | TinyPower™  |
| EfficientMax™   | IntelliMAX™            | RapidConfigure™   | TinyPWM™  |
| EZSWITCH™ *   | ISOPLANAR™             | Saving our world, 1mW at a time™  | TinyWire™   |
|  | MegaBuck™              | SmartMax™   | μSerDes™  |
|  | MICROCOUPLER™          | SMART START™  |  |
| Fairchild®  | MicroFET™              | SPM®  | UHC®  |
| Fairchild Semiconductor®  | MicroPak™              | STEALTH™  | Ultra FRFET™  |
| FACT Quiet Series™  | MillerDrive™           | SuperFET™   | UniFET™   |
| FACT®   | MotionMax™             | SuperSOT™.3   | Vcx™  |
| FAST®   | Motion-SPM™            | SuperSOT™.6   | VisualMax™  |
| FastvCore™  | OPTOLOGIC®             | SuperSOT™.8   |   |
| FlashWriter® *  | OPTOPLANAR®            | SupreMOS™   |   |
|   |                        | SyncFET™  |   |
|   |                        |  |   |

\* EZSWITCH™ and FlashWriter® are trademarks of System General Corporation, used under license by Fairchild Semiconductor.

**DISCLAIMER**

FAIRCHILD SEMICONDUCTOR RESERVES THE RIGHT TO MAKE CHANGES WITHOUT FURTHER NOTICE TO ANY PRODUCTS HEREIN TO IMPROVE RELIABILITY, FUNCTION, OR DESIGN. FAIRCHILD DOES NOT ASSUME ANY LIABILITY ARISING OUT OF THE APPLICATION OR USE OF ANY PRODUCT OR CIRCUIT DESCRIBED HEREIN, NEITHER DOES IT CONVEY ANY LICENSE UNDER ITS PATENT RIGHTS, NOR THE RIGHTS OF OTHERS. THESE SPECIFICATIONS DO NOT EXPAND THE TERMS OF FAIRCHILD'S WORLDWIDE TERMS AND CONDITIONS, SPECIFICALLY THE WARRANTY THEREIN, WHICH COVERS THESE PRODUCTS.

**LIFE SUPPORT POLICY**

FAIRCHILD'S PRODUCTS ARE NOT AUTHORIZED FOR USE AS CRITICAL COMPONENTS IN LIFE SUPPORT DEVICES OR SYSTEMS WITHOUT THE EXPRESS WRITTEN APPROVAL OF FAIRCHILD SEMICONDUCTOR CORPORATION.

As used herein:

1. Life support devices or systems are devices or systems which, (a) are intended for surgical implant into the body or (b) support or sustain life, and (c) whose failure to perform when properly used in accordance with instructions for use provided in the labeling, can be reasonably expected to result in a significant injury of the user.
2. A critical component in any component of a life support, device, or system whose failure to perform can be reasonably expected to cause the failure of the life support device or system, or to affect its safety or effectiveness.

**ANTI-COUNTERFEITING POLICY**

Fairchild Semiconductor Corporation's Anti-Counterfeiting Policy. Fairchild's Anti-Counterfeiting Policy is also stated on our external website, [www.fairchildsemi.com](http://www.fairchildsemi.com), under Sales Support.

Counterfeiting of semiconductor parts is a growing problem in the industry. All manufacturers of semiconductor products are experiencing counterfeiting of their parts. Customers who inadvertently purchase counterfeit parts experience many problems such as loss of brand reputation, substandard performance, failed applications, and increased cost of production and manufacturing delays. Fairchild is taking strong measures to protect ourselves and our customers from the proliferation of counterfeit parts. Fairchild strongly encourages customers to purchase Fairchild parts either directly from Fairchild or from Authorized Fairchild Distributors who are listed by country on our web page cited above. Products customers buy either from Fairchild directly or from Authorized Fairchild Distributors are genuine parts, have full traceability, meet Fairchild's quality standards for handling and storage and provide access to Fairchild's full range of up-to-date technical and product information. Fairchild and our Authorized Distributors will stand behind all warranties and will appropriately address any warranty issues that may arise. Fairchild will not provide any warranty coverage or other assistance for parts bought from Unauthorized Sources. Fairchild is committed to combat this global problem and encourage our customers to do their part in stopping this practice by buying direct or from authorized distributors.

**PRODUCT STATUS DEFINITIONS**

**Definition of Terms**

Datasheet Identification	Product Status	Definition
Advance Information	Formative / In Design	Datasheet contains the design specifications for product development. Specifications may change in any manner without notice.
Preliminary	First Production	Datasheet contains preliminary data; supplementary data will be published at a later date. Fairchild Semiconductor reserves the right to make changes at any time without notice to improve design.
No Identification Needed	Full Production	Datasheet contains final specifications. Fairchild Semiconductor reserves the right to make changes at any time without notice to improve the design.
Obsolete	Not In Production	Datasheet contains specifications on a product that is discontinued by Fairchild Semiconductor. The datasheet is for reference information only.

Rev. 135