

REVISIONS			
REV.	DESCRIPTION	DATE	APPROVED
A	INITIAL RELEASE	07/18/18	D.N.

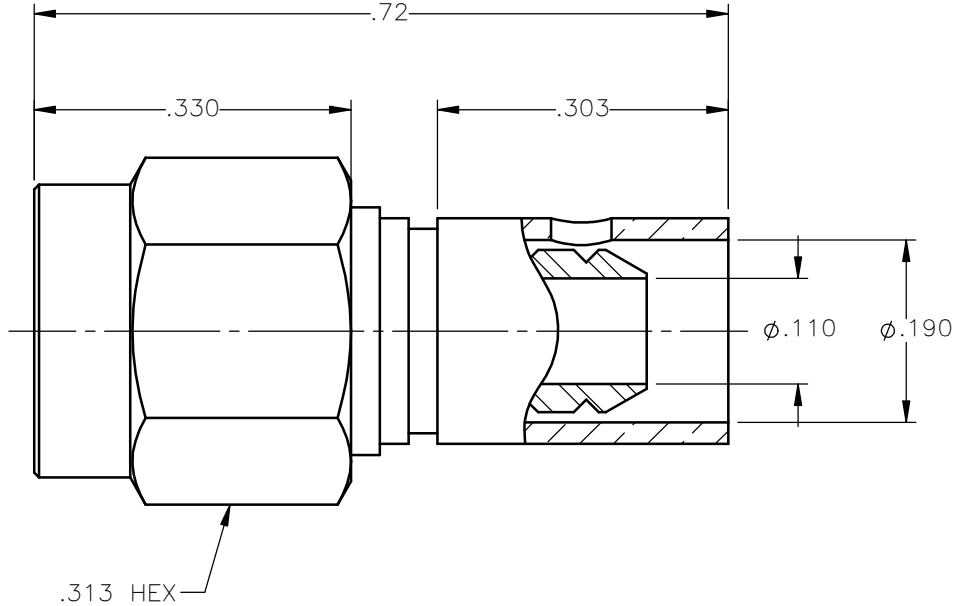

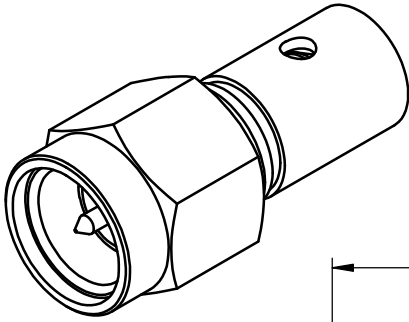

NOTES:

MATERIALS:

1. BODY & COUPLING NUT = STAINLESS STEEL PER ASTM A582, ALLOY 303, CONDITION "A".
2. INSULATOR = VIRGIN WHITE TEFLON PER ASTM D1710, GRADE 1, TYPE I, CLASS "B".
3. CONTACT & RETAINING RING = BERYLLIUM COPPER PER ASTM B196, ALLOY C17300, TEMPER TD04.
4. CRIMP SLEEVE = SEAMLESS LOWLEAD BRASS TUBE, ALLOY 330, SOFT ANNEAL TEMPER, .025/.060 GRAIN SIZE OR SEAMLESS COPPER TUBE PER ASTM B75, TYPE C12000, TEMPER: LIGHT ANNEAL O50 EXCEPT YIELD STRENGTH.
5. GASKET = SILICONE RUBBER PER ZZ-R-765, CLASS 2B, GRADE 65-75.
6. SHRINK SLEEVE = THERMOFIT SCL (NOT SHOWN)

FINISHES:

1. BODY = GOLD PLATE PER ASTM B488-11, TYPE II, 30µin MIN, GRADE C, OVER 50 TO 100µin STRESS FREE NICKEL PER AMS-QQ-N-290.
2. CONTACT = GOLD PLATE PER ASTM B488-11, TYPE II, 50µin MIN, GRADE C, OVER 100 TO 200µin STRESS FREE SULFAMATE NICKEL PER AMS-QQ-N-290.
3. CRIMP SLEEVE = GOLD PLATE PER ASTM B488-11, TYPE II, 30µin MIN, GRADE C OVER 100 TO 200µin COPPER STRIKE PER AMS 2418.
4. COUPLING NUT = PASSIVATE PER SAE-AMS-2700

UNLESS OTHERWISE SPECIFIED DIMENSIONS ARE IN INCHES TOLERANCES ON	DWN: DATE		Property of Radiall			
	D.N. DATE		This document cannot be reproduced or communicated to a third party without prior written permission of RADIALL.			
DECIMAL	ANGLE	CHKD: DATE	SMA STRAIGHT PLUG SOLDER TYPE FOR RG-180 & SIMILAR CABLES			
		C.E. DATE				
		APVD: DATE	SIZE	FSCM NO.	DWG NO.	REV
		J.M. DATE	A	19505	9001-1033-004	A
REFERENCE:	MATERIALS & FINISHES:	SCALE 5:1		THIRD ANGLE PROJECTION		SHEET 1 OF 1
ORIGINATED: D.N. DATE: 07/18/18	SEE NOTES					

9001-1033-004