

THIS DRAWING IS UNPUBLISHED. RELEASED FOR PUBLICATION
 © COPYRIGHT - BY TYCO ELECTRONICS CORPORATION. ALL RIGHTS RESERVED.

LOC	DIST	REVISIONS					
AG	53	P	LTR	DESCRIPTION	DATE	DWN	APVD
			A	REVISED PER ECO-06-001742	31JAN06	JDP	JGH

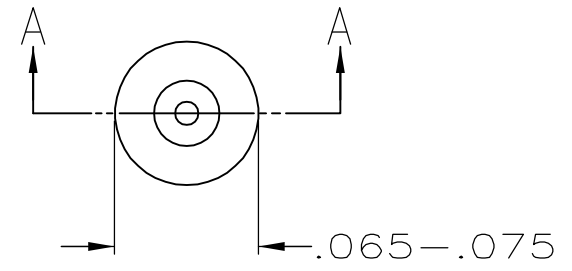

- MATERIAL:
 EYELET - COPPER PER ASTM B 152
 SPRING - BERYLLIUM COPPER PER ASTM B 194
- TIN PLATE PER ASTM B 545 .000100 MIN THICK.
- GOLD PLATE PER ASTM B 488 .000030 MIN THICK OVER NICKEL PER QQ-N-290 ON CONTACT AREA.
- TO INSURE 1/2 OZ MIN RETENTION DO NOT EXCEED .004 DIFFERENCE IN PIN DIA WHEN CHANGING TO A SMALLER DIA PIN
- HOLE SIZE FOR HAND INSERTION .053-.055

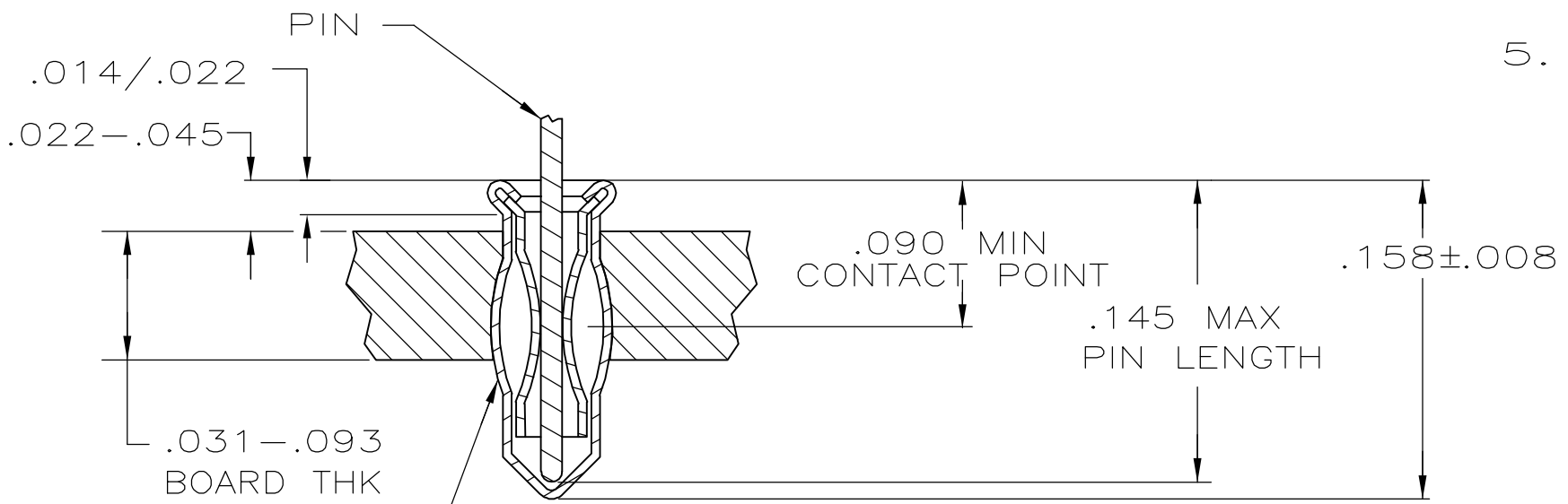

INSERTION MACHINE CAPABLE OF OVALIZING SOCKET FOR RETENTION IN PC BOARD WITH .052±.003 DIA HOLE PRIOR TO SOLDERING OPERATION

SECTION A-A

.090/.145	.014/.022	GOLD $\triangle 3$	TIN $\triangle 2$	5645951-5
	.020/.026	TIN $\triangle 2$		5645951-2
LENGTH	DIA $\triangle 4$	SPRING	EYELET	5645951-1
PIN		FINISH		PART NO

THIS DRAWING IS A CONTROLLED DOCUMENT.		DWN L. VARELA - DOCK5 19APR2005	Tyco Electronics Corporation Harrisburg, PA 17105-3608		
DIMENSIONS: INCHES	TOLERANCES UNLESS OTHERWISE SPECIFIED:	CHK J. HAVENER 19APR2005	NAME MINIATURE SPRING SOCKET ASSEMBLY SERIES 2 SHORT		
	0 PLC ± -	APVD J. HAVENER 19APR2005	PRODUCT SPEC 108-14008		
	1 PLC ± -		APPLICATION SPEC 114-13152		
MATERIAL	FINISH	WEIGHT	SIZE	CAGE CODE	DRAWING NO
NOTE 1	SEE TABLE	-	A3	00779	C=5645951
CUSTOMER DRAWING			SCALE	SHEET	REV
			NTS	1 OF 1	A