

ORDER NO.	WOODHEAD NO.	COLOR
130147-0117	29W81MB	YELLOW

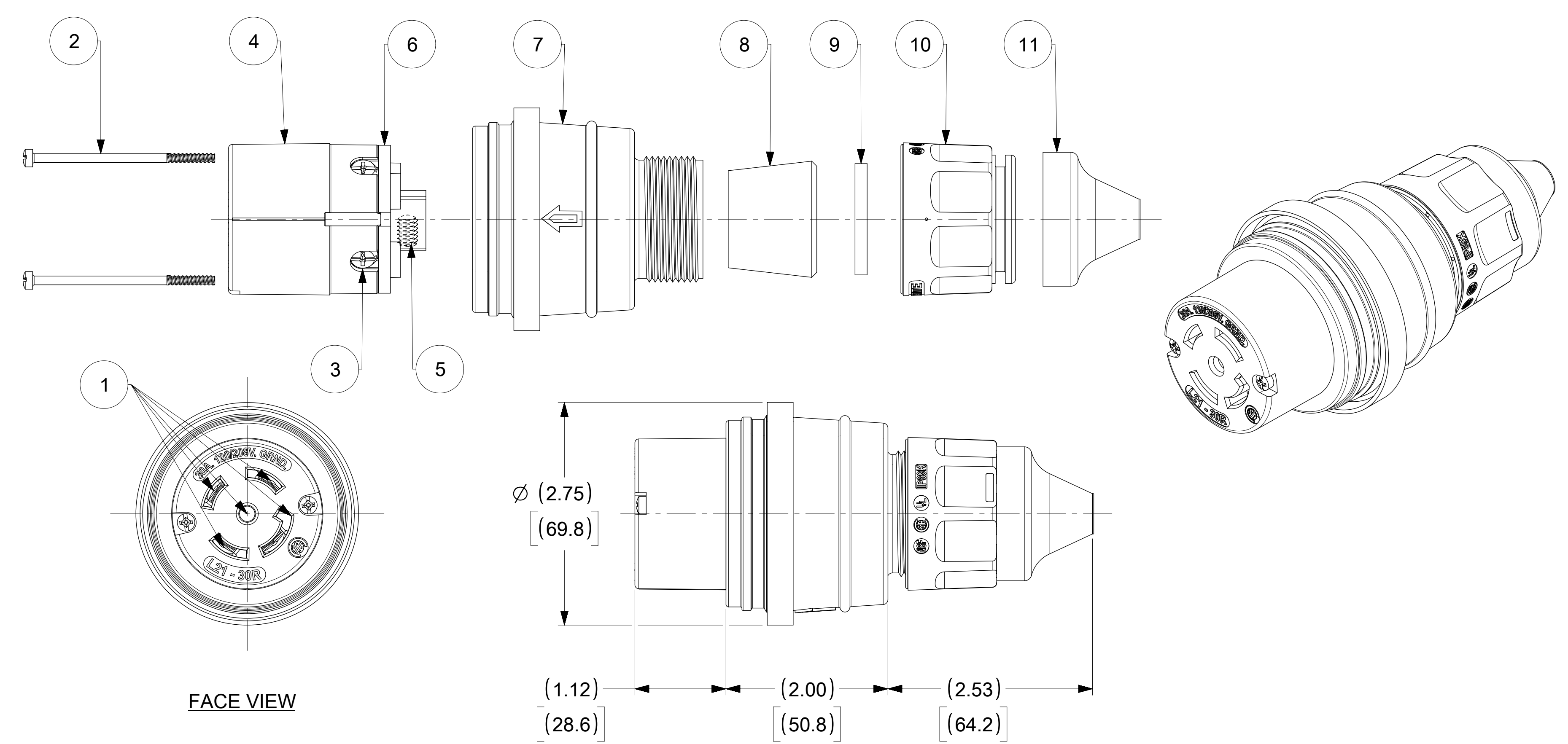

ITEM NO.	DESCRIPTIONS	MATERIAL	QTY.
1	BLADE	BRASS, NICKEL PLATED	5
2	RETAINING SCREWS	STAINLESS STEEL	2
3	CLAMP AND TERMINAL SCREW ASSY	BRASS, ZINC PLATED	4
4	INSERT	NYLON	1
5	SET SCREW	STAINLESS STEEL	1
6	TERMINAL COVER	POLYCARBONATE	1
7	HOUSING	SILICONE WITH NYLON THREAD	1
8	GROMMET	RUBBER	2
9	FRICTION RING	NYLON	1
10	COMPRESSION NUT	NYLON	1
11	CABLE GLOVE	SILICONE	1

NOTE:  
1. "ACCEPT CABLE RANGE FROM .562" TO 1.00"

SYMBOLS DIMENSION UNITS: INCH[MM] SCALE: NTS GENERAL TOLERANCES (UNLESS SPECIFIED): 4 PLACES ± ± 3 PLACES ± ± 2 PLACES ± ± 1 PLACE ± ± 0 PLACES ± ± ANGULAR TOL ± ° DRAFT WHERE APPLICABLE MUST REMAIN WITHIN DIMENSIONS		THIS DRAWING CONTAINS INFORMATION THAT IS PROPRIETARY TO MOLEX ELECTRONIC TECHNOLOGIES, LLC AND SHOULD NOT BE USED WITHOUT WRITTEN PERMISSION CURRENT REV DESC: EC NO: 617702 DRWN: SRPATIL 2019/02/20 CHK'D: DNGUYEN62 2019/05/24 APPR: HKNEELAND 2019/10/16 INITIAL REVISION: DRWN: SRPATIL 2019/02/20 APPR: HKNEELAND 2019/10/16 THIRD ANGLE PROJECTION DRAWING SERIES: C-SIZE 130147		<b>molex</b> WATERTITE CONNECTOR MOTOR BASE 4P5W L21-30 PRODUCT CUSTOMER DRAWING DOCUMENT NUMBER: 1301470117 DOC TYPE: PSD DOC PART: 000 REVISION: A MATERIAL NUMBER: SEE TABLE CUSTOMER: GENERAL MARKET SHEET NUMBER: 1 OF 1		
--	--	--	--	---	--	--