

Customer Information Sheet

DRAWING No.: P70-2300045R

IF IN DOUBT - ASK

©

NOT TO SCALE

THIRD ANGLE PROJECTION

ALL DIMENSIONS IN mm

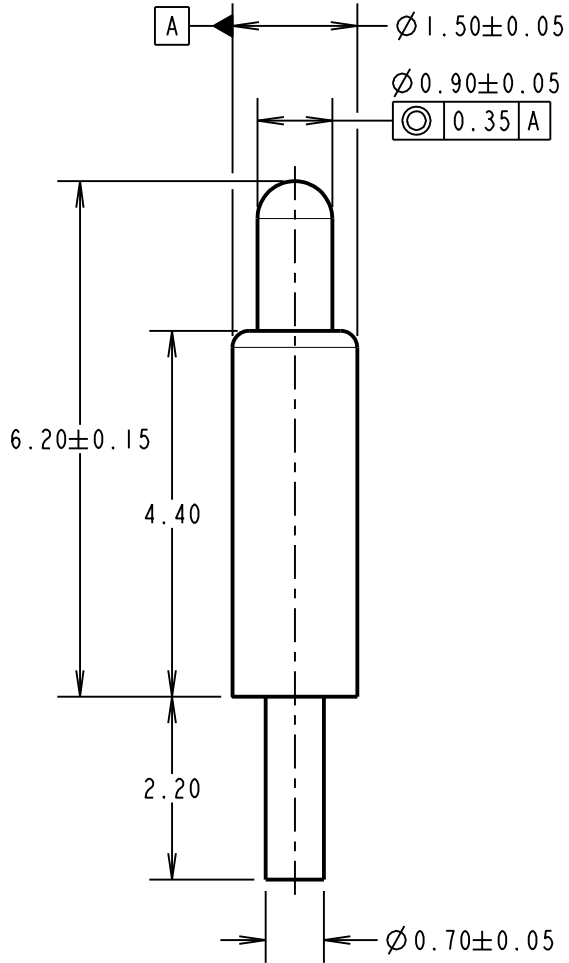

COMPONENT DETAILS

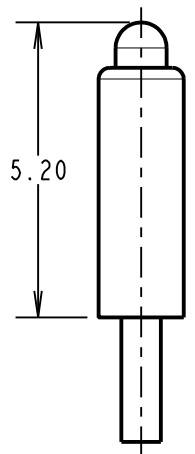

MAXIMUM WORKING HEIGHT

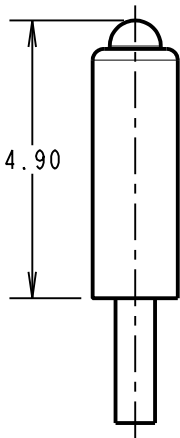

NORMAL WORKING HEIGHT

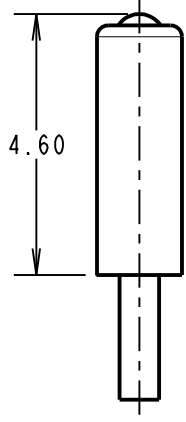

MINIMUM WORKING HEIGHT/MAX ALLOWED TRAVEL

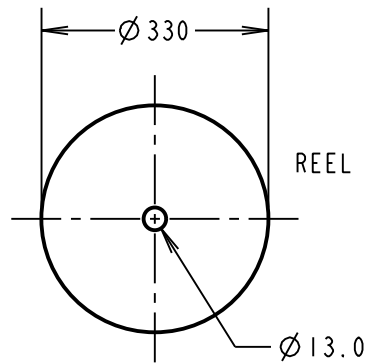
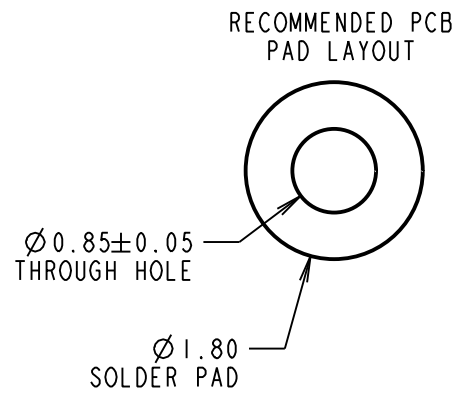

REEL DETAILS

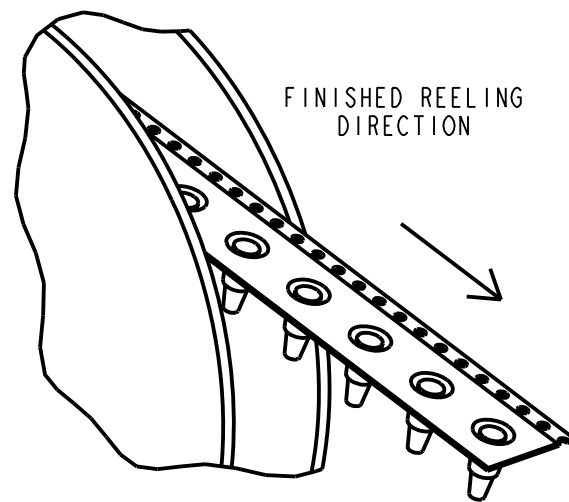
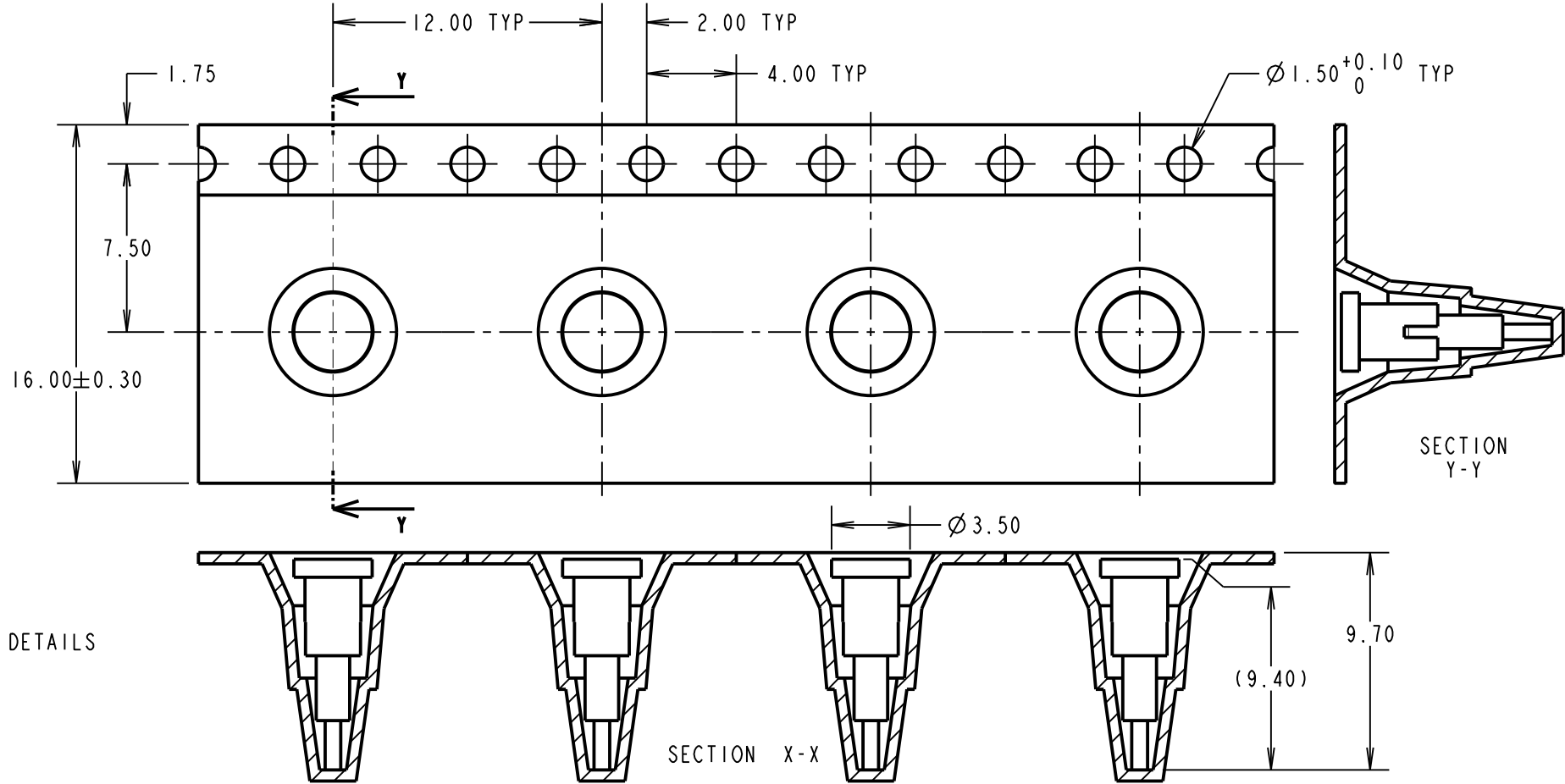

FINISHED REELING DIRECTION

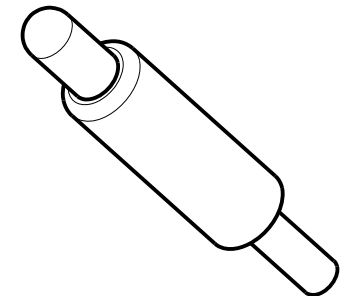

- NOTES:
 1. ALL PRODUCTS ARE RoHS COMPLIANT.
 2. PRODUCT IS TAPE AND REELED IN GENERAL ACCORDANCE WITH EIA-481 (ELECTRONIC INDUSTRIES ASSOCIATION).

SPECIFICATION:
 MATERIAL:
 BODY & PLUNGER = BRASS
 SPRING = STAINLESS STEEL WIRE
 PLATING:
 BODY = 0.1µm GOLD OVER 1.4µm NICKEL
 PLUNGER = 0.4µm GOLD OVER 1.4µm NICKEL
 ELECTRICAL:
 CONTACT RESISTANCE = 30mΩ MAX
 CURRENT RATING = 2.0A
 MECHANICAL:
 FORCE AT NORMAL HEIGHT = 0.83N ±0.25N
 DURABILITY = 10,000 CYCLES
 ENVIRONMENTAL:
 OPERATING TEMPERATURE = -40°C TO 85°C
 PACKING
 QUANTITY: 580 COMPONENTS PER REEL

RTP	3	02.07.21	30572
NAME	ISS.	DATE	CN/CO
APPROVED:		R.PORTLOCK	
CHECKED:		M.RUDKIN	
DRAWN:		S.BENNETT	
CUSTOMER REF.:			
ASSEMBLY DRG:			

HARWIN

www.harwin.com
 technical@harwin.com

THIS DRAWING AND ANY INFORMATION OR DESCRIPTIVE MATTER SET OUT HEREON ARE CONFIDENTIAL AND COPYRIGHT PROPERTY OF THE HARWIN GROUP AND MUST NOT BE DISCLOSED, LOANED, COPIED OR USED FOR MANUFACTURING, TENDERING OR FOR ANY OTHER PURPOSE WITHOUT THEIR WRITTEN PERMISSION.

TOLERANCES
 X. = ±1mm
 X.X = ±0.50mm
 X.XX = ±0.20mm
 X.XXX = ±0.01mm
 ANGLES = ±5°
 UNLESS STATED

MATERIAL:
 SEE ABOVE
 FINISH: SEE ABOVE
 S/AREA: mm²

TITLE: SMT SPRING LOADED POGO PIN WITH PEG, IN TAPE AND REEL
 DRAWING NUMBER: P70-2300045R
 SHT 2 OF 2