

PRODUCT DATA DRAWING

REVISION HISTORY			
REV	DESCRIPTION	DATE	APPROVED
01	PRELIMINARY	09/18/18	STW
-	REL. NRN 42893	01/02/19	STW

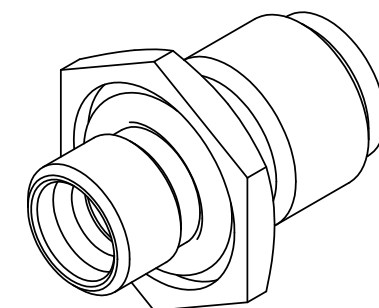
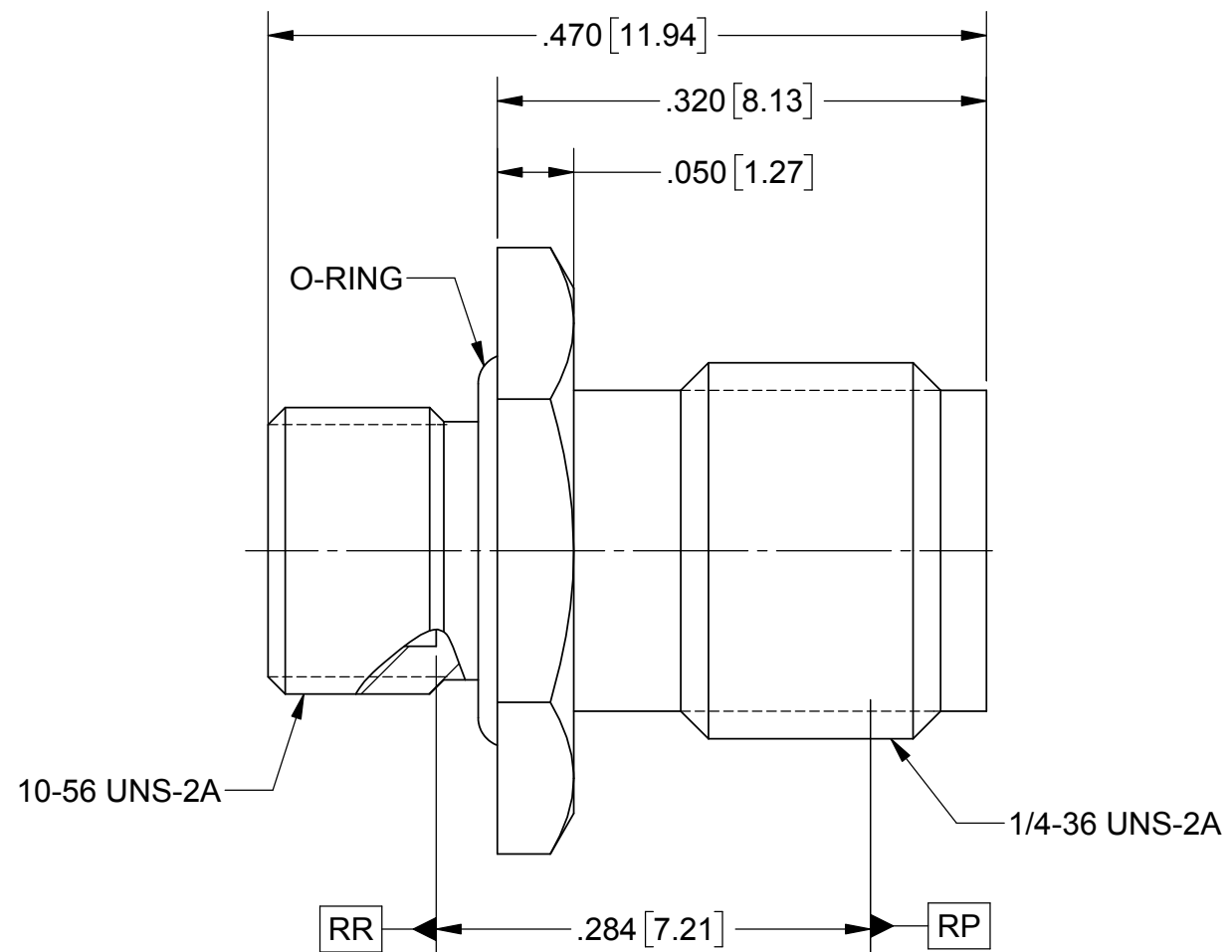
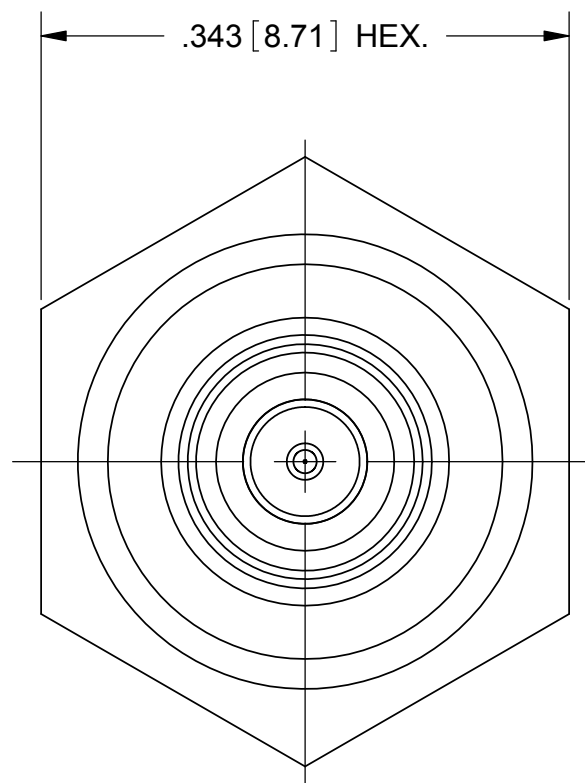

- MATERIAL:**
- BODY:** STAINLESS STEEL PER AMS 5640, ALLOY UNS S30300, TYPE 1 OR ASTM A582, TYPE 303, CONDITION A.
- CONTACT:** BERYLLIUM COPPER PER ASTM B196, ALLOY No. UNS C17300, TD04.
- INSULATOR:** PTFE PER ASTM D1710, TYPE I, GRADE 1, CLASS B.
- GLASS:** CORNING 7070 OR EQUIVALENT.
- PIN:** KOVAR PER ASTM F15.
- O-RING:** SILICONE RUBBER PER A-A-59588, CLASS 2B, GRADE 60 OR 70.
- FINISH:**

BODY, PIN & CONTACT: GOLD PER ASTM B488, TYPE II, CODE C, CLASS 1.27 OVER NICKEL PER AMS-QQ-N-290, CLASS 1, .00005" MIN.

PERFORMANCE:

IMPEDANCE: 50 OHMS
FREQ. RANGE: DC TO 18.0 GHZ
HERMETICITY: 1 X 10-8.

MATERIAL: SEE NOTES	DIMENSIONS ARE IN INCHES TOLERANCES: FRACTIONAL: ±1/64 ANGULAR: X° ±1'0" X'X' ±15'	UNLESS OTHERWISE SPECIFIED 1) ALL DIMENSIONS ARE IN INCHES (MILLIMETERS) 2) ALL DIMENSIONS ARE AFTER PLATING. 3) BREAK CORNERS & EDGES .005 R. MAX. 4) CHAM. 1ST & LAST THREADS. 5) SURFACE ROUGHNESS 63-MIL-STD-10. 6) DIA.'S ON COMMON CENTERS TO BE CONCENTRIC WITHIN .005 T.I.R. 7) REMOVE ALL BURRS	SV Microwave, Inc. 2400 Centrepark West Drive, Suite 100 West Palm Beach, FL 33409
FINISH: SEE NOTES	DECIMAL: X ±.030 .XX ±.010 .XXX ±.005	INTERPRET DIMENSIONS AND TOLERANCES PER ASME Y14.5M - 1994	TITLE: ADAPTER SMA FEM TO SMP FD MALE BLKHD MT HERMETICALLY SEALED
SURFACE AREA: N/A	THIRD ANGLE PROJECTION	DRAWN: JMC 09/18/18 CHECKED: STW 09/18/18 APPROVED: STW 09/18/18	SIZE: B CAGE CODE: 95077 DWG. NO.: SF1112-6162
PROPRIETARY THE INFORMATION CONTAINED IN THIS DRAWING IS THE SOLE PROPERTY OF SV MICROWAVE, INC. ANY REPRODUCTION IN PART OR AS A WHOLE WITHOUT THE WRITTEN PERMISSION OF SV MICROWAVE, INC IS PROHIBITED.			SCALE: 8:1 SHEET 1 OF 1