



Shown with FM403-0111
and WB-711 attached
(each sold separately)

MADE
IN THE **USA**

Alternative Products (each sold separately):

- BD119-0000: Public Safety Kit
Includes:
 - FM403-0111: Face Mask Dispenser - Locking
 - MP-070: Sign Holder - Vertical
 - KS022-0012: Dual-Sided Floor Stand

Companion Products (each sold separately):

- See KS022-0012 Dispenser Cross Reference

Product Description:

- Dual-Sided Floor Stand
- Holds automatic hand sanitizer dispensers, bulk mask dispensers, glove box dispensers, or wipe dispensers
- Column with square base
- Includes MP-070: Sign Holder - Vertical
 - Holds any 8.5"W x 11"H sign
- Assembly hardware included
- Column - Quartz Beige Powder-Coated Aluminum
- Base - Quartz Beige Powder-Coated Steel
- Sign Holder - Clear PETG Plastic

Primary Area for Product Usage:

- Public and private areas where hand sanitizing is encouraged

Dispenses:

- Holds mask, glove, wipe and other dispensers, as well as, mountable automatic hand sanitizer dispensers no larger than 10.00"W (25.4 cm)

Product Specifications (overall external dimensions):

- 17.00"W x 52.96"H x 17.00"D (43.2 cm x 134.5 cm x 43.2 cm)
Total height with sign holder: 64.57"H (164.0 cm)
- 16.4 lbs (7.4 kg) - approximated

Mounting Specifications:

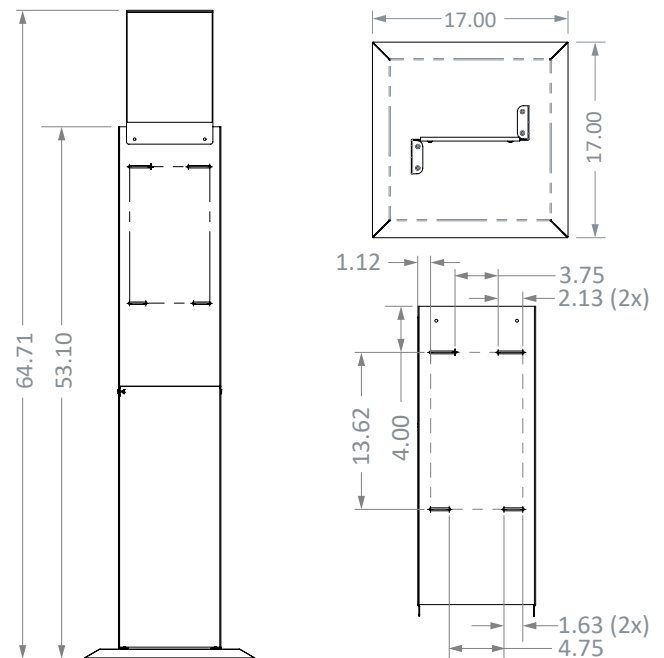

Package Specifications:

- Package Quantity: 1 per case
- 28"L x 18"W x 6"H (71.1 cm x 45.7 cm x 15.2 cm)
- 20.0 lbs (9.1 kg) - approximated





Installation

Always mount dispensers securely *prior* to loading with product.

- To secure base to column, place column over base (top of base is raised side).
- Using a Phillips screwdriver, attach all four panhead screws (10-32 x 5/16"). Tighten.

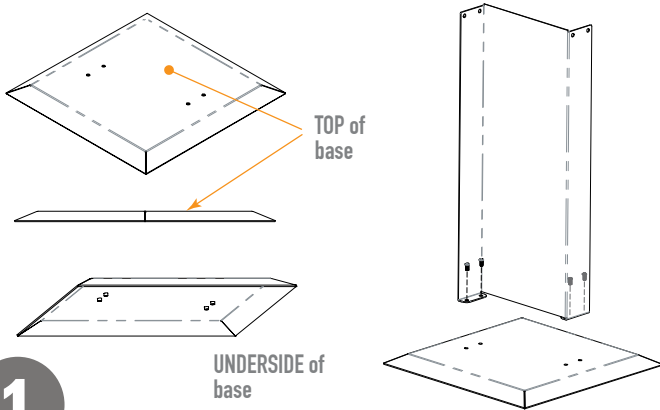
**1**

- Attach the top piece to the bottom assembly using 4 sets of the barrel screws.

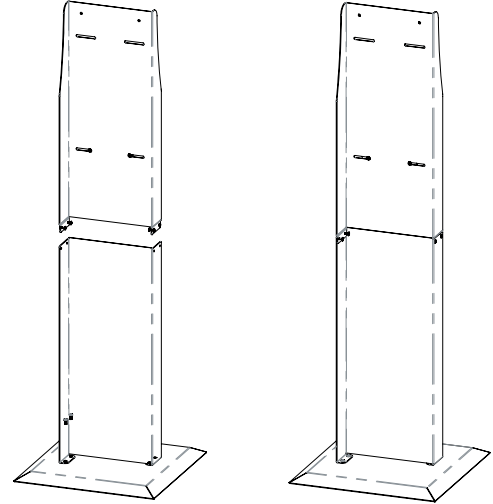
**2**

- Attach sign holder using 2 sets of barrel screws.
- Insert signage.
- Free alternate signs available for download at BowmanDispensers.com/free-signs

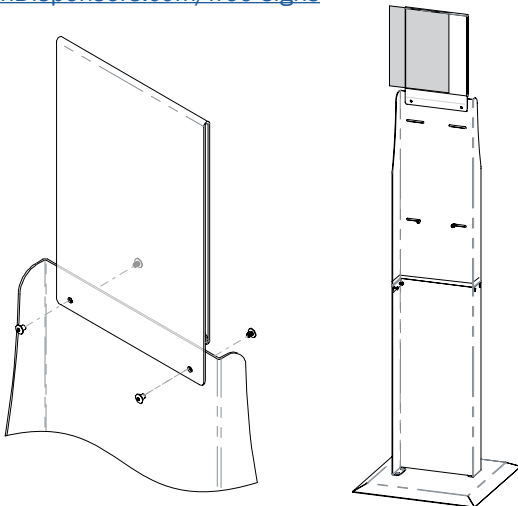
**3**

- Mount optional WB-711 or other dispenser (sold separately) on one side of the stand using slots and (2x) pair barrel screws.
- On the opposite side, mount empty hand sanitizer dispenser(s) (not sold by Bowman) or other dispensers (sold separately) with VHB tape (sold separately) or using the other set of slots.

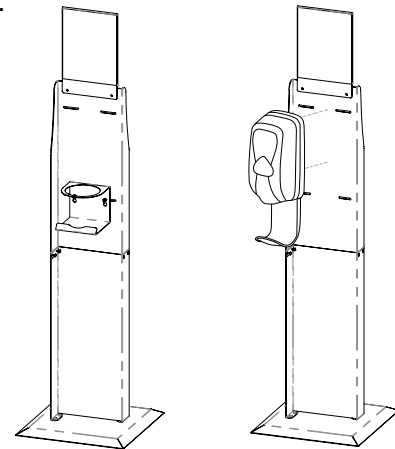
**4**

Parts included:

- Column
- Base
- Sign Holder
- Hardware
 - (4x) Panhead Screws (Phillips type 10-32 x 5/16")
 - (8x) Sets of barrel screws

Tools Required:

- Phillips and Flathead screwdrivers

**KS022-0012 Column**
Powder-Coated Aluminum**KS022-0012 Base**
Powder-Coated Steel**MP-070**
PETG Plastic**Material Characteristics****Designed for Long-Term Use**

Our powder-coated aluminum dispensers resist corrosion, chipping, and flaking. It is lightweight, yet high in strength. This material will provide long-lasting products that hold up well, even in tough environments.

Powder-coated aluminum is ideal for dispensers used in a healthcare or industrial settings. It is impact resistant and is not affected by extremes in temperature.

Dispensers made of powder-coated aluminum are clean, bright, and attractive, creating a professional appearance.

Designed for Long-Term Use

Our steel dispensers and stands are coated with polyester powders which makes them highly resistant to corrosion.

Powder-coated steel is ideal for dispensers used in a healthcare or an industrial setting because it is impact resistant and is not effected by extremes in temperature.

Dispensers and stands made of powder-coated steel are both attractive and functional, providing years of service.

Designed for Long-Term, Heavy-Duty Applications

Copolyester resin is designed for heavy-duty applications, and is used by BOWMAN® Dispensers. We never use acrylic in our products.

Copolyester (PETG) is typically 15-20 times tougher than general purpose acrylic. PETG is made to withstand handling and reduce losses due to breakage.

PETG resists a variety of chemicals and commonly used cleaning agents. It is tough and durable (not brittle), providing years of trouble-free functionality and long life.

Clear optical characteristics mean the viewer can see the content, read text, and see true colors through the material. It complies with FDA regulations for food contact.

Care and Cleaning

For best results, clean by washing the surface with a diluted solution of a mild, non-abrasive detergent in cold or warm water and a non-abrasive cloth. Standard hospital cleaning supplies can be used.

Dry with a soft cloth. Do not use any solvent-based materials, abrasives (e.g. Scotch-brite, steel wool), or apply excessive force during cleaning.

Most cleaning chemicals do not weaken the surface or cause damage to the material. Suggested cleaning method is to use a soft cloth, warm water, and mild soap.