

UCC23313 4-A Source, 5-A Sink, 3.75-kV_{RMS} Opto-Compatible Single Channel Isolated Gate Driver

1 Features

- 3.75-kV_{RMS} single channel isolated gate driver with opto-compatible input
- Pin-to-pin, drop in upgrade for opto isolated gate drivers
- 4.5-A source, 5.3-A sink, peak output current
- Maximum 33-V output driver supply voltage
- 8-V (B) and 12-V VCC UVLO options
- Rail-to-rail output
- 105-ns (maximum) propagation delay
- 25-ns (maximum) part-to-part delay matching
- 35-ns (maximum) pulse width distortion
- 150-kV/μs (minimum) common-mode transient immunity (CMTI)
- Isolation barrier life > 50 Years
- 13-V reverse polarity voltage handling capability on input stage supporting interlock
- Stretched SO-6 package with > 8.5-mm creepage and clearance
- Operating junction temperature, T_J: –40°C to +150°C
- Safety-related certifications (Planned):
 - 6000-V_{PK} basic isolation per DIN V VDE V0884-11: 2017-01
 - 3.75-kV_{RMS} isolation for 1 minute per UL 1577
 - CQC certification per GB4943.1-2011

2 Applications

- Industrial motor-control drives
- Industrial power supplies, UPS
- Solar inverters
- Induction heating

3 Description

The UCC23313 is an Opto-compatible, single-channel, isolated gate driver for IGBTs, MOSFETs and SiC MOSFETs, with 4.5-A source and 5.3-A sink peak output current and 3.75-kV_{RMS} basic isolation rating. The high supply voltage range of 33 V allows the use of bipolar supplies to effectively drive IGBTs and SiC power FETs. UCC23313 can drive both low side and high side power FETs. Key features and characteristics bring significant performance and reliability upgrades over standard opto-coupler based gate drivers while maintaining pin-to-pin compatibility in both schematic and layout design. Performance highlights include high common mode transient immunity (CMTI), low propagation delay, and small pulse width distortion. Tight process control results in small part-to-part skew. The input stage is an emulated diode (e-diode) which means long term reliability and excellent aging characteristics compared to traditional LEDs found in optocoupler gate drivers. It is offered in a stretched SO6 package with > 8.5-mm creepage and clearance, and a mold compound from material group I, which has a comparative tracking index (CTI) > 600 V. UCC23313's high performance and reliability makes it ideal for use in all types of motor drives, solar inverters, industrial power supplies, and appliances. The higher operating temperature opens up opportunities for applications not previously able to be supported by traditional optocouplers.

Device Information (1)

PART NUMBER	PACKAGE	BODY SIZE (NOM)
UCC23313	Stretched SO-6	7.5 mm x 4.68 mm

(1) For all available packages, see the orderable addendum at the end of the data sheet.

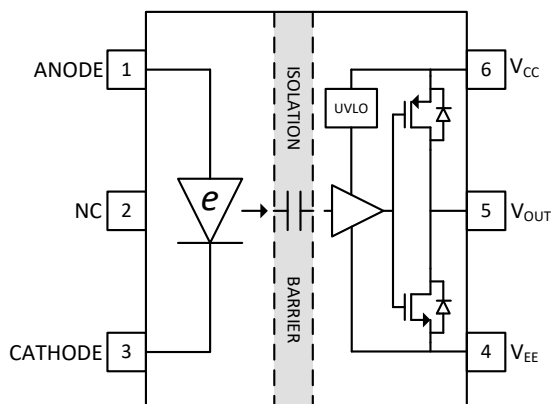

Functional Block Diagram



Table of Contents

1 Features	1	7 Parameter Measurement Information	13
2 Applications	1	7.1 Propagation Delay, rise time and fall time.....	13
3 Description	1	7.2 I _{OH} and I _{OL} testing.....	13
4 Revision History	2	7.3 CMTI Testing.....	13
5 Pin Configuration and Function	3	8 Detailed Description	14
Pin Functions.....	3	8.1 Overview.....	14
6 Specifications	4	8.2 Functional Block Diagram.....	15
6.1 Absolute Maximum Ratings.....	4	8.3 Feature Description.....	15
6.2 ESD Ratings.....	4	8.4 Device Functional Modes.....	19
6.3 Recommended Operating Conditions.....	4	9 Application and Implementation	20
6.4 Thermal Information.....	4	9.1 Application Information.....	20
6.5 Power Ratings.....	5	9.2 Typical Application.....	21
6.6 Insulation Specifications.....	6	10 Power Supply Recommendations	27
6.7 Safety-Related Certifications.....	7	11 Layout	28
6.8 Safety Limiting Values.....	7	11.1 Layout Guidelines.....	28
6.9 Electrical Characteristics.....	8	11.2 Layout Example.....	29
6.10 Switching Characteristics.....	8	11.3 PCB Material.....	31
6.11 Insulation Characteristics Curves.....	9	12 Mechanical, Packaging, and Orderable Information	32
6.12 Typical Characteristics.....	10		

4 Revision History

NOTE: Page numbers for previous revisions may differ from page numbers in the current version.

Changes from Revision A (October 2019) to Revision B (October 2020)	Page
• Added UCC23511B orderble to include 8-V UVLO option.....	8

Changes from Revision * (September 2019) to Revision A (October 2019)	Page
• Changed Minimum internal gap unit from mm to μm	6

5 Pin Configuration and Function

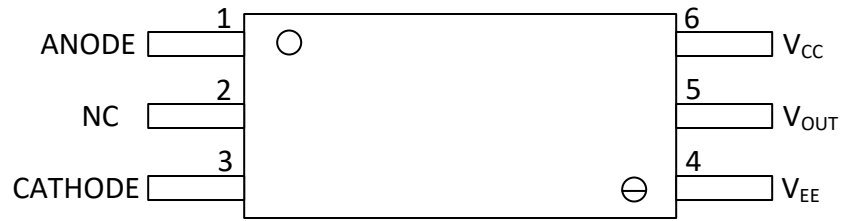

Figure 5-1. UCC23313 Package SO-6 Top View

Pin Functions

PIN		TYPE ⁽¹⁾	DESCRIPTION
NAME	NO. UCC23313		
ANODE	1	I	Anode
CATHODE	3	I	Cathode
NC	2	-	No Connection
V _{CC}	6	P	Positive output supply rail
V _{EE}	4	P	Negative output supply rail
V _{OUT}	5	O	Gate-drive output

(1) P = Power, G = Ground, I = Input, O = Output

6 Specifications

6.1 Absolute Maximum Ratings

Over operating free air temperature range (unless otherwise noted)⁽¹⁾

		MIN	MAX	UNIT
Average Input Current	$I_{F(AVG)}$	-	25	mA
Peak Transient Input Current	$I_{F(TRAN)} < 1\mu s \text{ pulse, } 300\text{pps}$		1	A
Reverse Input Voltage	$V_{R(MAX)}$		14	V
Output supply voltage	$V_{CC} - V_{EE}$	-0.3	35	V
Output signal voltage	$V_{OUT} - V_{CC}$		0.3	V
Output signal voltage	$V_{OUT} - V_{EE}$	-0.3		V
Junction temperature	T_J ⁽²⁾	-40	150	°C
Storage temperature	T_{stg}	-65	150	°C

- (1) Stresses beyond those listed under *Absolute Maximum Ratings* may cause permanent damage to the device. These are stress ratings only, which do not imply functional operation of the device at these or any other conditions beyond those indicated under *Recommended Operating Conditions*. Exposure to absolute-maximum-rated conditions for extended periods may affect device reliability.
- (2) To maintain the recommended operating conditions for T_J , see the *Thermal Information Section*.

6.2 ESD Ratings

			VALUE	UNIT
$V_{(ESD)}$	Electrostatic discharge	Human-body model (HBM), per AEC Q100-002 ⁽¹⁾	±4000	V
		Charged-device model (CDM), per AEC Q100-011	±1500	

- (1) AEC Q100-002 indicates that HBM stressing shall be in accordance with the ANSI/ESDA/JEDEC JS-001 specification.

6.3 Recommended Operating Conditions

Over operating free-air temperature range (unless otherwise noted)

		MIN	NOM	MAX	UNIT
V_{CC}	Output Supply Voltage($V_{CC} - V_{EE}$)	14		33	V
V_{CC}	Output Supply Voltage($V_{CC} - V_{EE}$)	10		33	V
I_F (ON)	Input Diode Forward Current (Diode "ON")	7		16	mA
V_F (OFF)	Anode voltage - Cathode voltage (Diode "OFF")	-13		0.9	V
T_J	Junction temperature	-40		150	°C
T_A	Ambient temperature	-40		125	°C

6.4 Thermal Information

THERMAL METRIC ⁽¹⁾		UCC23313		UNIT
		SO6		
		6 Pins		
$R_{\theta JA}$	Junction-to-ambient thermal resistance	126		°C/W
$R_{\theta JC(top)}$	Junction-to-case (top) thermal resistance	66.1		°C/W
$R_{\theta JB}$	Junction-to-board thermal resistance	62.8		°C/W
Ψ_{JT}	Junction-to-top characterization parameter	29.6		°C/W
Ψ_{JB}	Junction-to-board characterization parameter	60.8		°C/W

- (1) For more information about traditional and new thermal metrics, see the <http://www.ti.com/lit/SPRA953> application report.

6.5 Power Ratings

PARAMETER		TEST CONDITIONS	MIN	TYP	MAX	UNIT
P_D	Maximum power dissipation on input and output ⁽¹⁾	$V_{CC} = 20\text{ V}$, $I_F = 10\text{ mA}$ 10-kHz, 50% duty cycle, square wave, 180-nF load, $T_A = 25^\circ\text{C}$			750	mW
P_{D1}	Maximum input power dissipation ⁽²⁾				10	mW
P_{D2}	Maximum output power dissipation				740	mW

- (1) Derate at 6 mW/°C beyond 25°C ambient temperature
 (2) Recommended maximum $P_{D1} = 40\text{ mW}$. Absolute maximum $P_{D1} = 55\text{ mW}$

6.6 Insulation Specifications

PARAMETER		TEST CONDITIONS	SPECIFICATION	UNIT
CLR	External clearance ⁽¹⁾	Shortest terminal-to-terminal distance through air	>8.5	mm
CPG	External Creepage ⁽¹⁾	Shortest terminal-to-terminal distance across the package surface	>8.5	mm
DTI	Distance through the insulation	Minimum internal gap (internal clearance)	>17	μm
CTI	Comparative tracking index	DIN EN 60112 (VDE 0303-11); IEC 60112	>600	V
	Material Group	According to IEC 60664-1	I	
	Overvoltage category per IEC 60664-1	Rated mains voltage ≤ 600 V _{RMS}	I-IV	
		Rated mains voltage ≤ 1000 V _{RMS}	I-III	
DIN V VDE 0884-11 (VDE V 0884-11)⁽²⁾				
V _{IORM}	Maximum repetitive peak isolation voltage	AC voltage (bipolar)	990	V _{PK}
V _{IOWM}	Maximum isolation working voltage	AC voltage (sine wave); time-dependent dielectric breakdown (TDDb) test; see Figure 1	700	V _{RMS}
		DC voltage	990	V _{DC}
V _{IOTM}	Maximum transient isolation voltage	V _{TEST} = V _{IOTM} , t = 60 sec (qualification) V _{TEST} = 1.2 × V _{IOTM} , t = 1 s (100% production)	5300	V _{PK}
V _{IOSM}	Maximum surge isolation voltage ⁽³⁾	Test method per IEC 62368, 1.2/50 ms waveform, V _{TEST} = 1.6 × V _{IOSM} = 9600 V _{PK} (qualification)	6000	V _{PK}
q _{pd}	Apparent charge ⁽⁴⁾	Method a: After I/O safety test subgroup 2/3, V _{ini} = V _{IOTM} , t _{ini} = 60 s; V _{pd(m)} = 1.2 × V _{IORM} = 1188 V _{PK} , t _m = 10 s	≤5	pC
		Method a: After environmental tests subgroup 1, V _{ini} = V _{IOTM} , t _{ini} = 60 s; V _{pd(m)} = 1.6 × V _{IORM} = 1584 V _{PK} , t _m = 10 s	≤5	
		Method b1: At routine test (100% production) and preconditioning (type test), V _{ini} = V _{IOTM} , t _{ini} = 1 s; V _{pd(m)} = 1.875 × V _{IORM} = 1856 V _{PK} , t _m = 1 s	≤5	
C _{IO}	Barrier capacitance, input to output ⁽⁵⁾	V _{IO} = 0.4 × sin(2πft), f = 1 MHz	0.5	pF
R _{IO}	Insulation resistance, input to output ⁽⁵⁾	V _{IO} = 500 V, T _A = 25°C	>10 ¹²	Ω
		V _{IO} = 500 V, 100°C ≤ T _A ≤ 125°C	>10 ¹¹	
		V _{IO} = 500 V at T _S = 150°C	>10 ⁹	
	Pollution degree		2	
	Climatic category		40/125/21	
UL 1577				
V _{ISO}	Withstand isolation voltage	V _{TEST} = V _{ISO} = 3750 V _{RMS} , t = 60 s (qualification), V _{TEST} = 1.2 × V _{ISO} = 4500 V _{RMS} , t = 1 s (100% production)	3750	V _{RMS}

- Creepage and clearance requirements should be applied according to the specific equipment isolation standards of an application. Care should be taken to maintain the creepage and clearance distance of a board design to ensure that the mounting pads of the isolator on the printed-circuit board do not reduce this distance. Creepage and clearance on a printed-circuit board become equal in certain cases. Techniques such as inserting grooves, ribs, or both on a printed-circuit board are used to help increase these specifications.
- This coupler is suitable for *safe electrical insulation* only within the safety ratings. Compliance with the safety ratings shall be ensured by means of suitable protective circuits.
- Testing is carried out in air or oil to determine the intrinsic surge immunity of the isolation barrier.
- Apparent charge is electrical discharge caused by a partial discharge (pd).
- All pins on each side of the barrier tied together creating a two-pin device.

6.7 Safety-Related Certifications

VDE	UL	CQC
Plan to certify according to DIN V VDE V 0884-11: 2017-01	Plan to certify according to UL 1577 Component Recognition Program	Plan to certify according to GB4943.1-2011
Basic insulation Maximum transient isolation voltage, 5300 V _{PK} ; Maximum repetitive peak isolation voltage, 990 V _{PK} ; Maximum surge isolation voltage, 6000 V _{PK}	Single protection, 3750 V _{RMS}	
Certificate planned	Certificate planned	Certificate planned

6.8 Safety Limiting Values

PARAMETER		TEST CONDITIONS	MIN	TYP	MAX	UNIT
I _S	Safety input, output, or supply current	R _{qJA} = 126°C/W, V _I = 15 V, T _J = 150°C, T _A = 25°C			50	mA
		R _{qJA} = 126°C/W, V _I = 30 V, T _J = 150°C, T _A = 25°C			25	
P _S	Safety input, output, or total power	R _{qJA} = 126°C/W, T _J = 150°C, T _A = 25°C			750	mW
T _S	Maximum safety temperature ⁽¹⁾				150	°C

- (1) The maximum safety temperature, T_S, has the same value as the maximum junction temperature, T_J, specified for the device. The I_S and P_S parameters represent the safety current and safety power respectively. The maximum limits of I_S and P_S should not be exceeded. These limits vary with the ambient temperature, T_A. The junction-to-air thermal resistance, R_{qJA}, in the Thermal Information table is that of a device installed on a high-K test board for leaded surface-mount packages. Use these equations to calculate the value for each parameter: T_J = T_A + R_{qJA} · P, where P is the power dissipated in the device. T_{J(max)} = T_S = T_A + R_{qJA} · P_S, where T_{J(max)} is the maximum allowed junction temperature. P_S = I_S · V_I, where V_I is the maximum supply voltage.

6.9 Electrical Characteristics

Unless otherwise noted, all typical values are at $T_A = 25^\circ\text{C}$, $V_{CC}-V_{EE} = 15\text{V}$, $V_{EE} = \text{GND}$. All min and max specifications are at recommended operating conditions ($T_J = -40^\circ\text{C}$ to 150°C , $I_{F(\text{on})} = 7\text{ mA}$ to 16 mA , $V_{EE} = \text{GND}$, $V_{CC} = 15\text{ V}$ to 30 V , $V_{F(\text{off})} = -5\text{V}$ to 0.8V)

PARAMETER		TEST CONDITIONS	MIN	TYP	MAX	UNIT
INPUT						
I_{FLH}	Input forward threshold current low to High	$V_{OUT} > 5\text{ V}$, $C_g = 1\text{ nF}$	1.5	2.8	4	mA
V_F	Input Forward Voltage	$I_F = 10\text{ mA}$	1.8	2.1	2.4	V
V_{F_HL}	Threshold input voltage High to low	$V < 5\text{ V}$, $C_g = 1\text{ nF}$	0.9			V
$\Delta V_F/\Delta T$	Temp coefficient of Input forward voltage	$I_F = 10\text{ mA}$		1	1.35	mV/°C
V_R	Input Reverse Breakdown voltage	$I_R = 10\text{ uA}$	15			V
C_{IN}	Input Capacitance	$F = 0.5\text{ MHz}$		15		pF
OUTPUT						
I_{OH}	High Level Peak Output Current	$I_F = 10\text{ mA}$, $V_{CC} = 15\text{V}$, $C_{LOAD} = 0.18\text{uF}$, $C_{VDD} = 10\text{uF}$, pulse width $< 10\text{us}$	3	4.5		A
I_{OL}	Low Level Peak Output Current	$V_F = 0\text{ V}$, $V_{CC} = 15\text{V}$, $C_{LOAD} = 0.18\text{uF}$, $C_{VDD} = 10\text{uF}$, pulse width $< 10\text{us}$	3.5	5.3		A
V_{OH}	High Level Output Voltage	$I_F = 10\text{ mA}$, $I_O = -20\text{mA}$ (with respect to VCC)	0.07	0.18	0.36	V
		$I_F = 10\text{ mA}$, $I_O = 0\text{ mA}$		VCC		V
V_{OL}	Low Level Output Voltage	$V_F = 0\text{ V}$, $I_O = 20\text{ mA}$			25	mV
I_{CC_H}	Output Supply Current (Diode On)	$I_F = 10\text{ mA}$, $I_O = 0\text{ mA}$			2.2	mA
I_{CC_L}	Output Supply Current (Diode Off)	$V_F = 0\text{ V}$, $I_O = 0\text{ mA}$			2	mA
UNDER VOLTAGE LOCKOUT, UCC23313 (12-V UVLO Version)						
$UVLO_R$	Under Voltage Lockout VCC rising	V_{CC_Rising} , $I_F = 10\text{ mA}$	11	12.5	13.5	V
$UVLO_F$	Under Voltage Lockout VCC falling	$V_{CC_Falling}$, $I_F = 10\text{ mA}$	10	11.5	12.5	V
$UVLO_{HYS}$	UVLO Hysteresis			1.0		V
UNDER VOLTAGE LOCKOUT, UCC23313B (8-V UVLO Version)						
$UVLO_R$	Under Voltage Lockout VCC rising	V_{CC_Rising} , $I_F = 10\text{ mA}$	7.8	8.5	9.2	V
$UVLO_F$	Under Voltage Lockout VCC falling	$V_{CC_Falling}$, $I_F = 10\text{ mA}$	7.05	7.75	8.45	V
$UVLO_{HYS}$	UVLO Hysteresis			0.75		V

6.10 Switching Characteristics

Unless otherwise noted, all typical values are at $T_A = 25^\circ\text{C}$, $V_{CC}-V_{EE} = 30\text{ V}$, $V_{EE} = \text{GND}$. All min and max specifications are at recommended operating conditions ($T_J = -40$ to 150°C , $I_{F(\text{ON})} = 7\text{ mA}$ to 16 mA , $V_{EE} = \text{GND}$, $V_{CC} = 15\text{ V}$ to 30 V , $V_{F(\text{OFF})} = -5\text{V}$ to 0.8V)

PARAMETER		TEST CONDITIONS	MIN	TYP	MAX	UNIT
t_r	Output-signal Rise Time	$C_g = 1\text{ nF}$ $F_{SW} = 20\text{ kHz}$, (50% Duty Cycle) $V_{CC} = 15\text{V}$			28	ns
t_f	Output-signal Fall Time				25	ns
t_{PLH}	Propagation Delay, Low to High		70	105	ns	
t_{PHL}	Propagation Delay, High to Low		70	105	ns	
t_{PWD}	Pulse Width Distortion $ t_{PHL} - t_{PLH} $				35	ns
$t_{sk(pp)}$	Part-to-Part Skew in Propagation Delay Between any Two Parts ⁽¹⁾	$C_g = 1\text{ nF}$ $F_{SW} = 20\text{ kHz}$, (50% Duty Cycle) $V_{CC} = 15\text{V}$, $I_F = 10\text{mA}$			25	ns
t_{UVLO_rec}	UVLO Recovery Delay	V_{CC} Rising from 0V to 15V		20	30	μs

Unless otherwise noted, all typical values are at $T_A = 25^\circ\text{C}$, $V_{CC}-V_{EE} = 30\text{ V}$, $V_{EE} = \text{GND}$. All min and max specifications are at recommended operating conditions ($T_J = -40$ to 150°C , $I_{F(\text{ON})} = 7\text{ mA}$ to 16 mA , $V_{EE} = \text{GND}$, $V_{CC} = 15\text{ V}$ to 30 V , $V_{F(\text{OFF})} = -5\text{ V}$ to 0.8 V)

PARAMETER		TEST CONDITIONS	MIN	TYP	MAX	UNIT
CMT _H	Common-mode Transient Immunity (Output High)	$I_F = 10\text{ mA}$, $V_{CM} = 1500\text{ V}$, $V_{CC} = 30\text{ V}$, $T_A = 25^\circ\text{C}$	150			kV/ μs
CMT _L	Common-mode Transient Immunity (Output Low)	$V_F = 0\text{ V}$, $V_{CM} = 1500\text{ V}$, $V_{CC} = 30\text{ V}$, $T_A = 25^\circ\text{C}$	150			kV/ μs

- (1) $t_{sk(pp)}$ is the magnitude of the difference in propagation delay times between the output of different devices switching in the same direction while operating at identical supply voltages, temperature, input signals and loads ensured by characterization.

6.11 Insulation Characteristics Curves

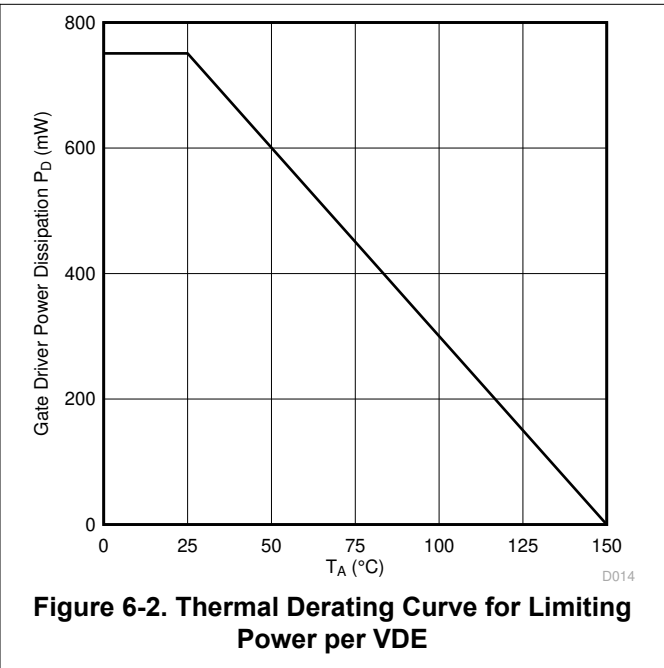
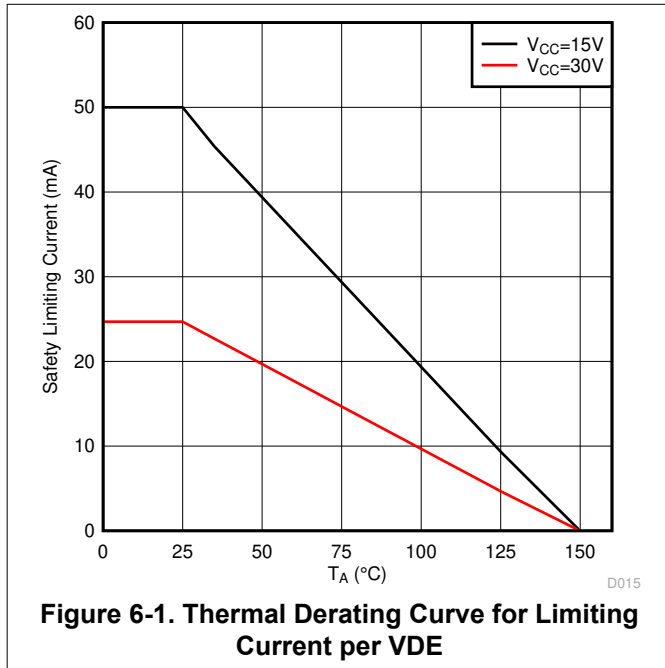

6.12 Typical Characteristics

$V_{CC} = 15\text{ V}$, $1\text{-}\mu\text{F}$ capacitor from V_{CC} to V_{EE} , $C_{LOAD} = 1\text{ nF}$ for timing tests and 180 nF for I_{OH} and I_{OL} tests, $T_J = -40^\circ\text{C}$ to $+150^\circ\text{C}$, (unless otherwise noted)

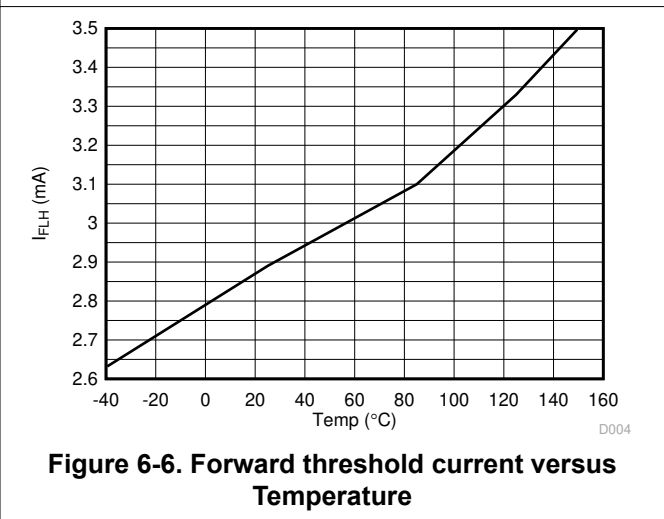
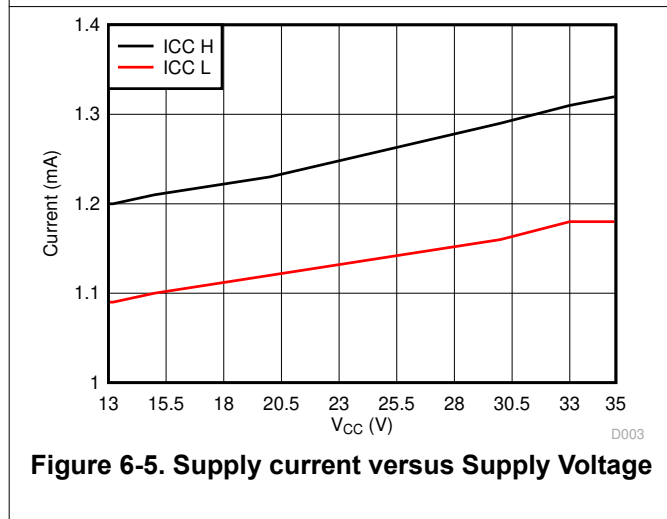
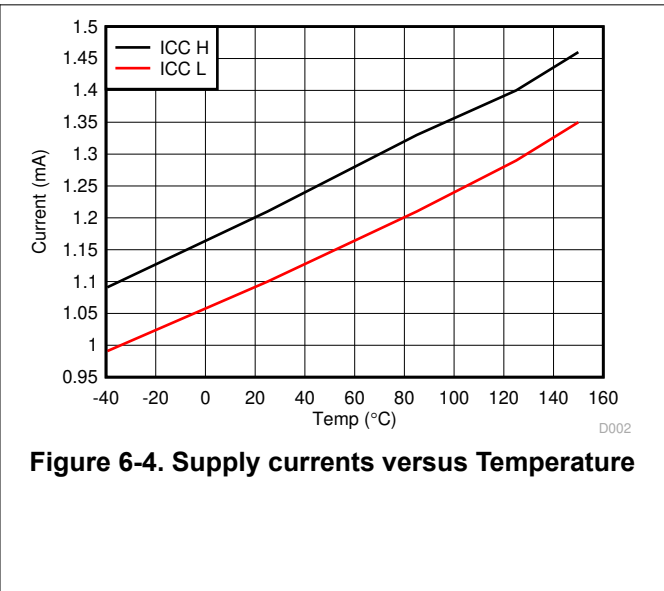
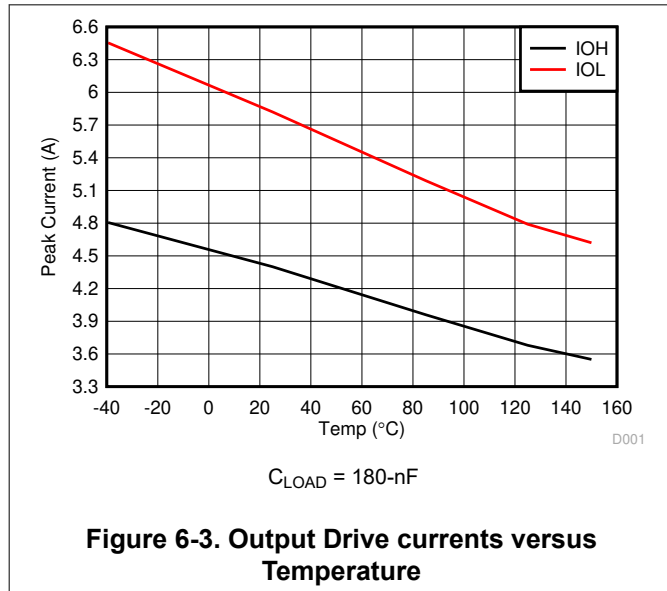

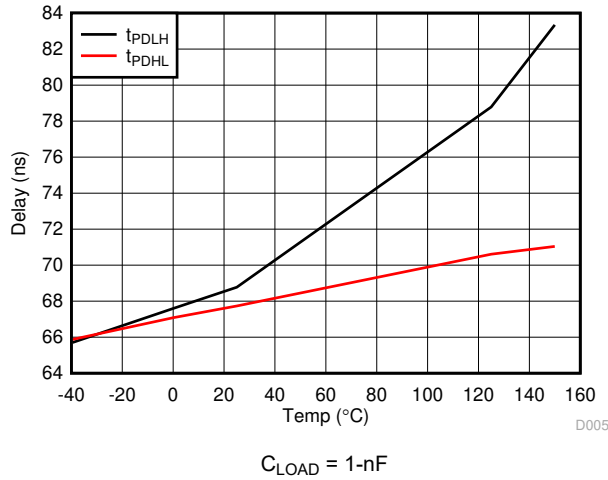

Figure 6-7. Propagation delay versus Temperature

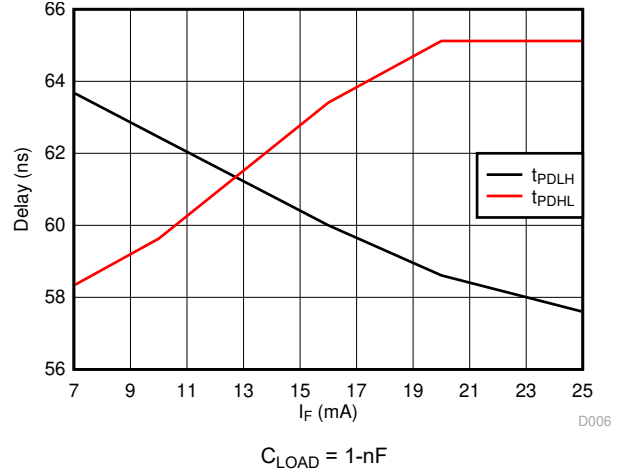
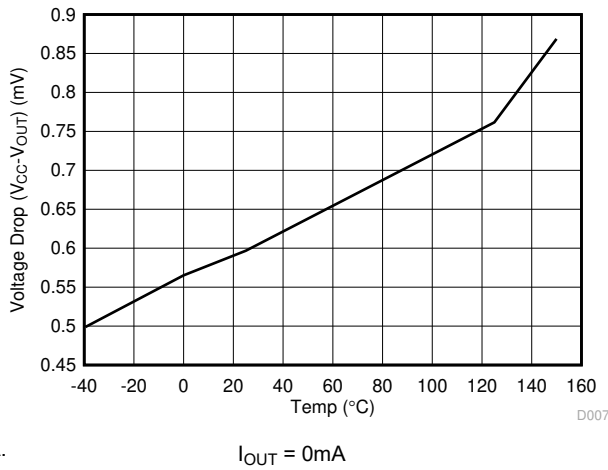
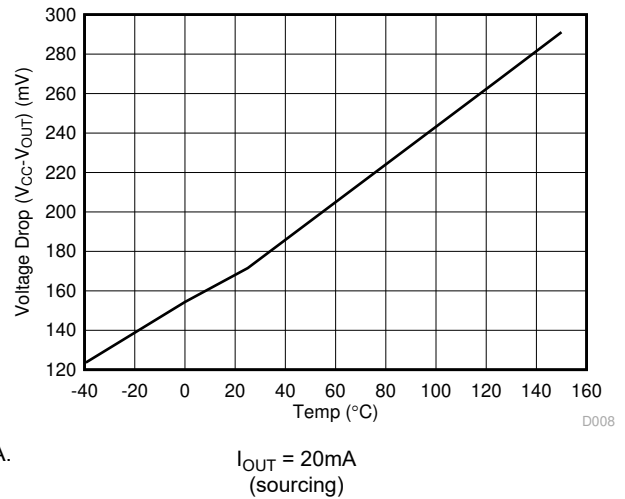

Figure 6-8. Propagation delay versus Forward current



A. $I_{OUT} = 0\text{mA}$
Figure 6-9. V_{OH} (No Load) versus Temperature



A. $I_{OUT} = 20\text{mA}$ (sourcing)
Figure 6-10. V_{OH} (20mA Load) versus Temperature

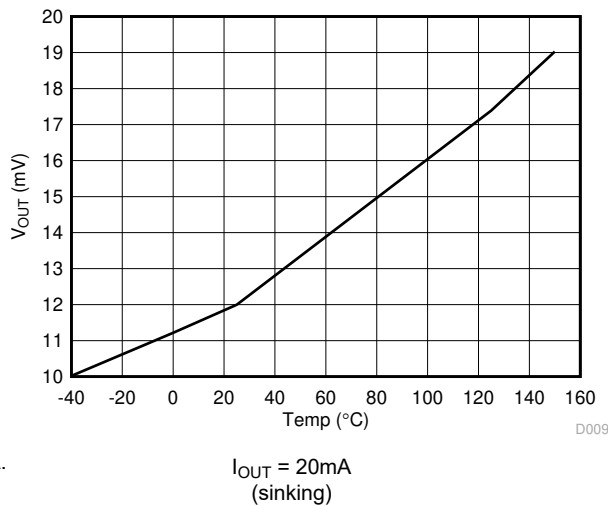

A. $I_{OUT} = 20\text{mA}$ (sinking)
Figure 6-11. V_{OL} versus Temperature

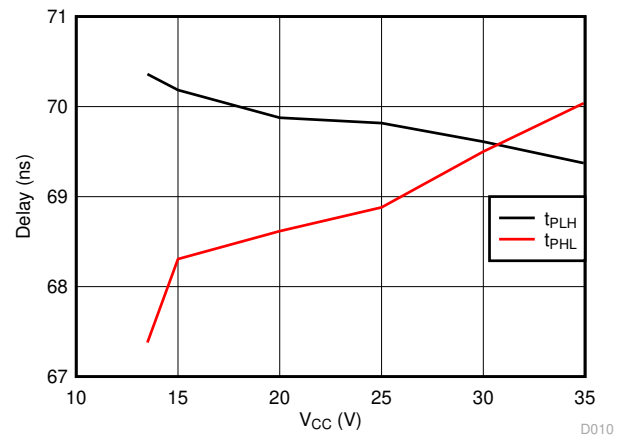

Figure 6-12. Propagation delay versus Supply voltage

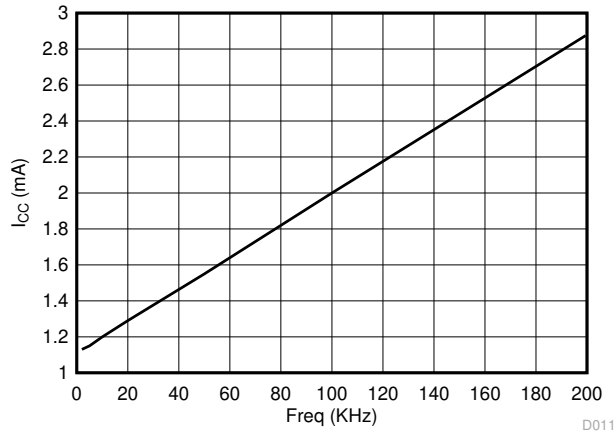
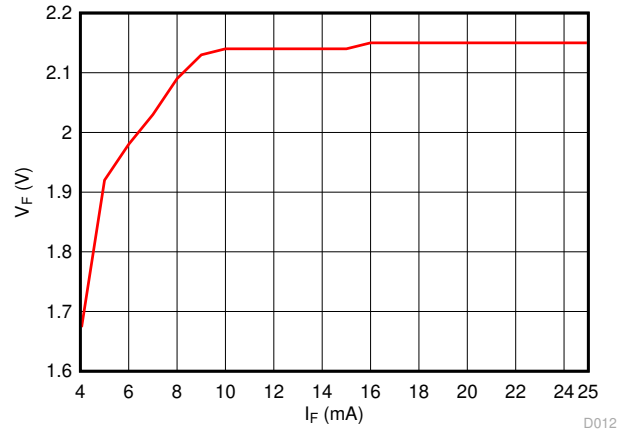

Figure 6-13. Supply current versus Frequency

D011



A.

T_A = 25°C

Figure 6-14. Forward current versus Forward voltage drop

D012

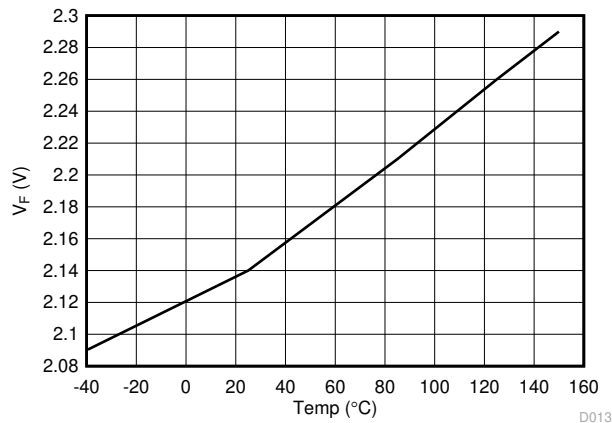

A.

I_F = 10mA

Figure 6-15. Forward voltage drop versus Temperature

D013

7 Parameter Measurement Information

7.1 Propagation Delay, rise time and fall time

Figure 7-1 shows the propagation delay from the input forward current I_F , to V_{OUT} . This figure also shows the circuit used to measure the rise (t_r) and fall (t_f) times and the propagation delays $t_{PD,LH}$ and $t_{PD,HL}$.

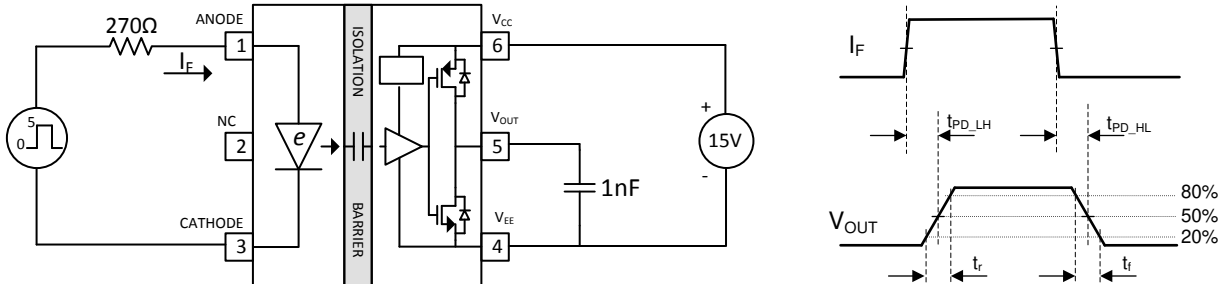

Figure 7-1. I_F to V_{OUT} Propagation Delay, Rise Time and Fall Time

7.2 I_{OH} and I_{OL} testing

Figure 7-2 shows the circuit used to measure the output drive currents I_{OH} and I_{OL} . A load capacitance of 180nF is used at the output. The peak dv/dt of the capacitor voltage is measured in order to determine the peak source and sink currents of the gate driver.

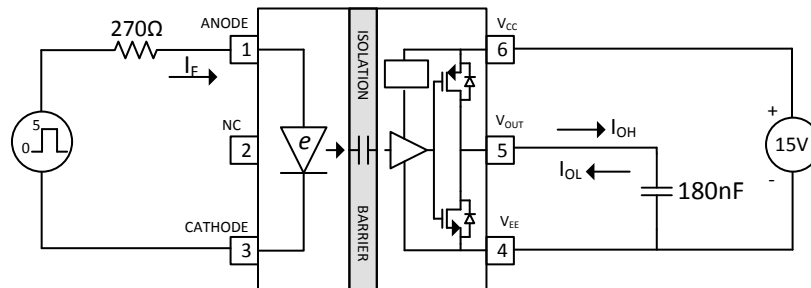

Figure 7-2. I_{OH} and I_{OL}

7.3 CMTI Testing

Figure 7-3 is the simplified diagram of the CMTI testing. Common mode voltage is set to 1500V. The test is performed with $I_F = 6mA$ ($V_{OUT} = High$) and $I_F = 0mA$ ($V_{OUT} = LOW$). The diagram also shows the fail criteria for both cases. During the application of the CMTI pulse with $I_F = 6mA$, if V_{OUT} drops from V_{CC} to $1/2V_{CC}$ it is considered as a failure. With $I_F = 0mA$, if V_{OUT} rises above 1V, it is considered as a failure.

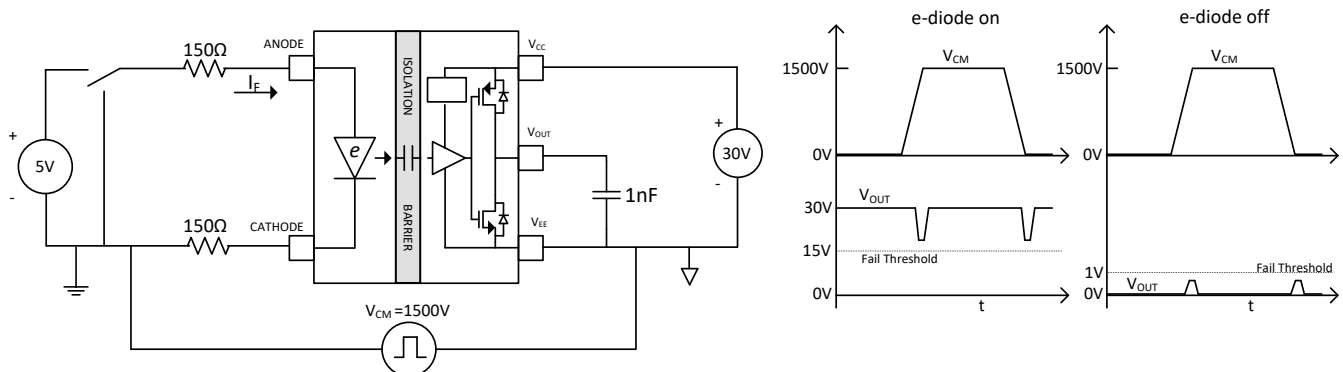

Figure 7-3. CMTI Test Circuit for UCC23313

8 Detailed Description

8.1 Overview

UCC23313 is a single channel isolated gate driver, with an opto-compatible input stage, that can drive IGBTs, MOSFETs and SiC FETs. It has 4A peak output current capability with max output driver supply voltage of 33V. The inputs and the outputs are galvanically isolated. UCC23313 is offered in an industry standard 6 pin (SO6) package with >8.5mm creepage and clearance. It has a working voltage of 700- V_{RMS} , isolation rating of 3.75 kV_{RMS} for 60s and a surge rating of 6 kV_{PK} . It is pin-to-pin compatible with standard opto isolated gate drivers. While standard opto isolated gate drivers use an LED as the input stage, UCC23313 uses an emulated diode (or "e-diode") as the input stage which does not use light emission to transmit signals across the isolation barrier. The input stage is isolated from the driver stage by dual, series HV SiO_2 capacitors in full differential configuration that not only provides isolation but also offers best-in-class common mode transient immunity of >150kV/us. The e-diode input stage along with capacitive isolation technology gives UCC23313 several performance advantages over standard opto isolated gate drivers. They are as follows:

- 1.
1. Since the e-diode does not use light emission for its operation, the reliability and aging characteristics of UCC23313 are naturally superior to those of standard opto isolated gate drivers.
2. Higher ambient operating temperature range of 125°C, compared to only 105°C for most opto isolated gate drivers
3. The e-diode forward voltage drop has less part-to-part variation and smaller variation across temperature. Hence, the operating point of the input stage is more stable and predictable across different parts and operating temperature.
4. Higher common mode transient immunity than opto isolated gate drivers
5. Smaller propagation delay than opto isolated gate drivers
6. Due to superior process controls achievable in capacitive isolation compared to opto isolation, there is less part-to-part skew in the prop delay, making the system design simpler and more robust
7. Smaller pulse width distortion than opto isolated gate drivers

The signal across the isolation has an on-off keying (OOK) modulation scheme to transmit the digital data across a silicon dioxide based isolation barrier (see [Figure 8-1](#)). The transmitter sends a high-frequency carrier across the barrier to represent one digital state and sends no signal to represent the other digital state. The receiver demodulates the signal after advanced signal conditioning and produces the output through a buffer stage. The UCC23313 also incorporates advanced circuit techniques to maximize the CMTI performance and minimize the radiated emissions from the high frequency carrier and IO buffer switching. [Figure 8-2](#) shows conceptual detail of how the OOK scheme works.

8.2 Functional Block Diagram

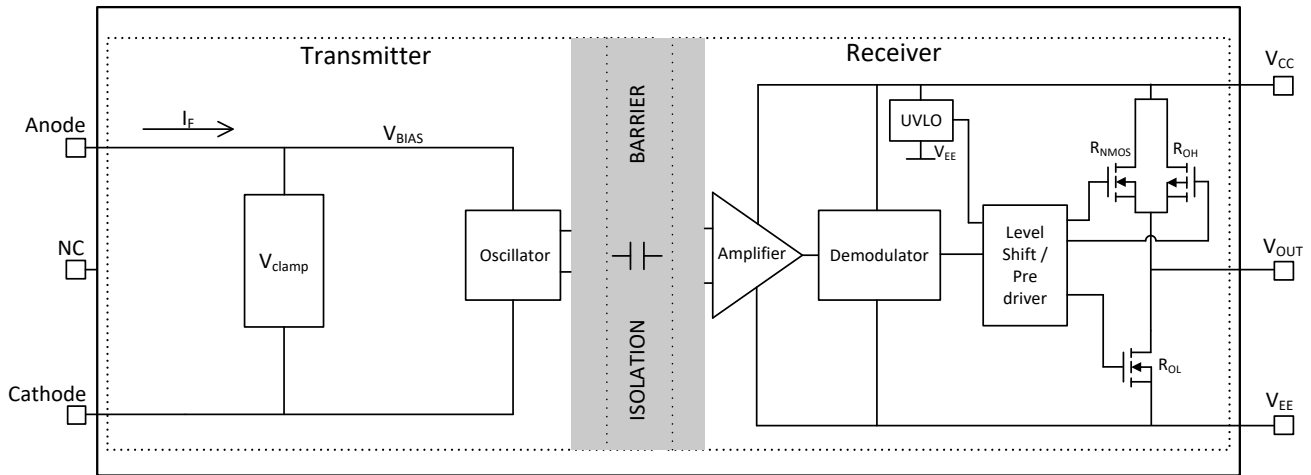

Figure 8-1. Conceptual Block Diagram of a Isolated Gate Driver with an Opto Emulated Input Stage (SO6 pkg)

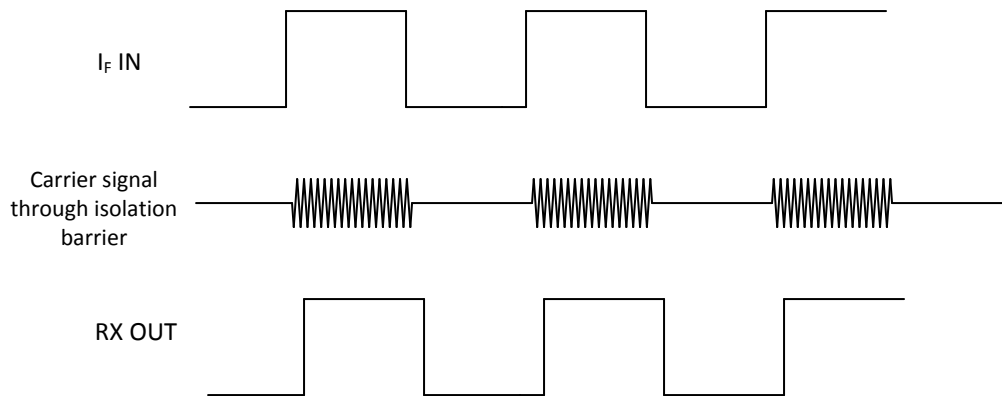

Figure 8-2. On-Off Keying (OOK) Based Modulation Scheme

8.3 Feature Description

8.3.1 Power Supply

Since the input stage is an emulated diode, no power supply is needed at the input.

The output supply, V_{CC} , supports a voltage range from 10 V to 33 V. For operation with bipolar supplies, the power device is turned off with a negative voltage on the gate with respect to the emitter or source. This configuration prevents the power device from unintentionally turning on because of current induced from the Miller effect. The typical values of the V_{CC} and V_{EE} output supplies for bipolar operation are 15V and -8V with respect to GND for IGBTs, and 20V and -5V for SiC MOSFETs.

For operation with unipolar supply, the V_{CC} supply is connected to 15V with respect to GND for IGBTs, and 20V for SiC MOSFETs. The V_{EE} supply is connected to 0V.

8.3.2 Input Stage

The input stage of UCC23313 is simply the e-diode and therefore has an Anode (Pin 1) and a Cathode (Pin 3). Pin 2 has no internal connection and can be left open or connected to ground. The input stage does not have a power and ground pin. When the e-diode is forward biased by applying a positive voltage to the Anode with respect to the Cathode, a forward current I_F flows into the e-diode. The forward voltage drop across the e-diode is 2.1V (typ). An external resistor should be used to limit the forward current. The recommended range for the forward current is 7mA to 16mA. When I_F exceeds the threshold current I_{FLH} (2.8mA typ.) a high frequency signal

is transmitted across the isolation barrier through the high voltage SiO₂ capacitors. The HF signal is detected by the receiver and V_{OUT} is driven high. See [Section 9.2.2.1](#) for information on selecting the input resistor. The dynamic impedance of the e-diode is very small (<1.0Ω) and the temperature coefficient of the e-diode forward voltage drop is <1.35mV/°C. This leads to excellent stability of the forward current I_F across all operating conditions. If the Anode voltage drops below V_{F_HL} (0.9V), or reverse biased, the gate driver output is driven low. The reverse breakdown voltage of the e-diode is >15V. So for normal operation, a reverse bias of up to 13V is allowed. The large reverse breakdown voltage of the e-diode enables UCC23313 to be operated in interlock architecture (see example in [Figure 8-3](#)) where V_{SUP} can be as high as 12V. The system designer has the flexibility to choose a 3.3V, 5.0V or up to 12V PWM signal source to drive the input stage of UCC23313 using an appropriate input resistor. The example shows two gate drivers driving a set of IGBTs. The inputs of the gate drivers are connected as shown and driven by two buffers that are controlled by the MCU. Interlock architecture prevents both the e-diodes from being "ON" at the same time, preventing shoot through in the IGBTs. It also ensures that if both PWM signals are erroneously stuck high (or low) simultaneously, both gate driver outputs will be driven low.

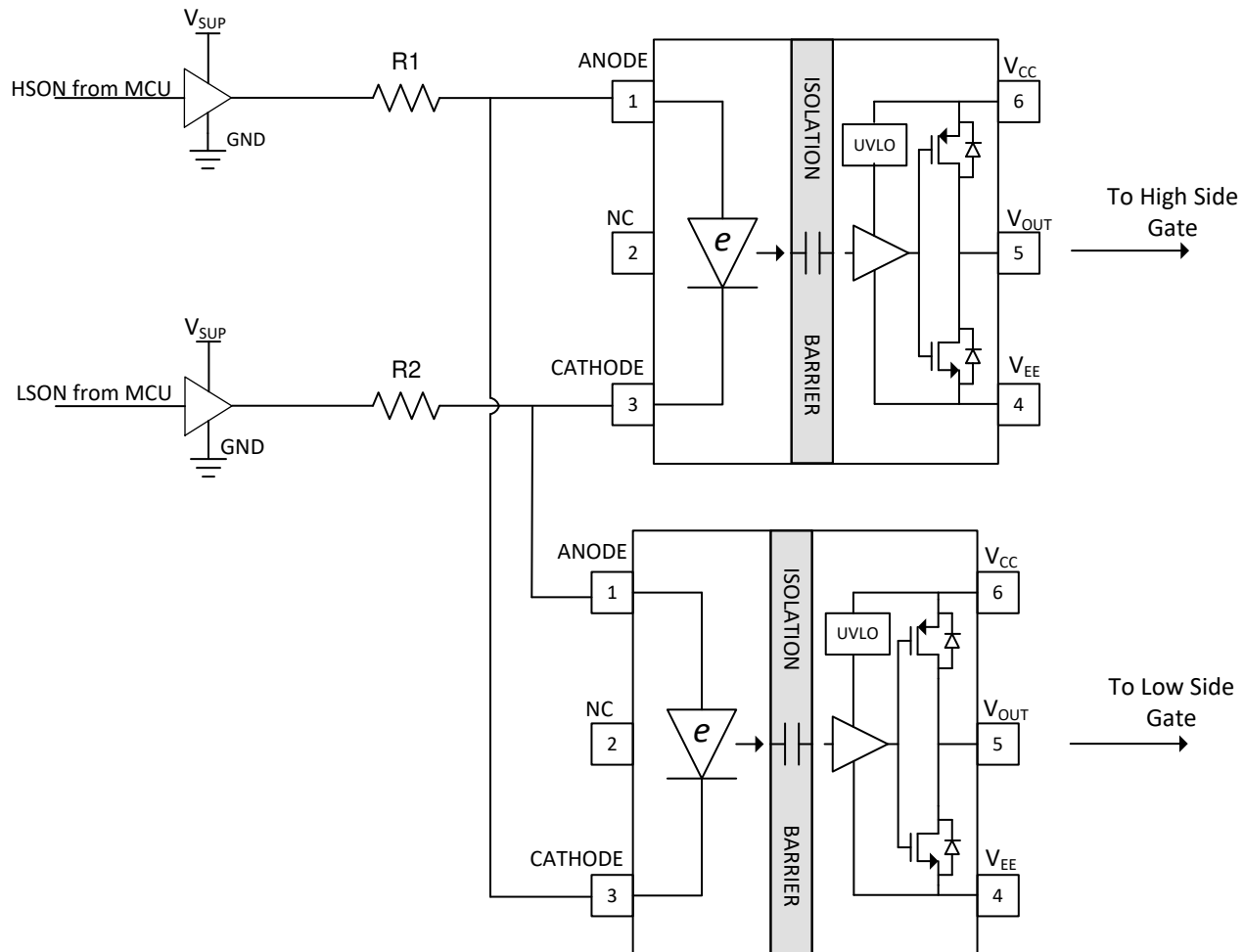

Figure 8-3. Interlock

8.3.3 Output Stage

The output stages of the UCC23313 family feature a pullup structure that delivers the highest peak-source current when it is most needed which is during the Miller plateau region of the power-switch turnon transition (when the power-switch drain or collector voltage experiences dV/dt). The output stage pullup structure features a P-channel MOSFET and an additional pull-up N-channel MOSFET in parallel. The function of the N-channel MOSFET is to provide a brief boost in the peak-sourcing current, enabling fast turnon. Fast turnon is accomplished by briefly turning on the N-channel MOSFET during a narrow instant when the output is changing

states from low to high. The on-resistance of this N-channel MOSFET (R_{NMOS}) is approximately 5.1 Ω when activated.

Table 8-1. UCC23313 On-Resistance

R_{NMOS}	R_{OH}	R_{OL}	UNIT
5.1	9.5	0.40	Ω

The R_{OH} parameter is a DC measurement and is representative of the on-resistance of the P-channel device only. This parameter is only for the P-channel device because the pullup N-channel device is held in the OFF state in DC condition and is turned on only for a brief instant when the output is changing states from low to high. Therefore, the effective resistance of the UCC23313 pullup stage during this brief turnon phase is much lower than what is represented by the R_{OH} parameter, yielding a faster turn on. The turnon-phase output resistance is the parallel combination $R_{OH} \parallel R_{NMOS}$.

The pulldown structure in the UCC23313 is simply composed of an N-channel MOSFET. The output voltage swing between V_{CC} and V_{EE} provides rail-to-rail operation because of the MOS-out stage which delivers very low dropout.

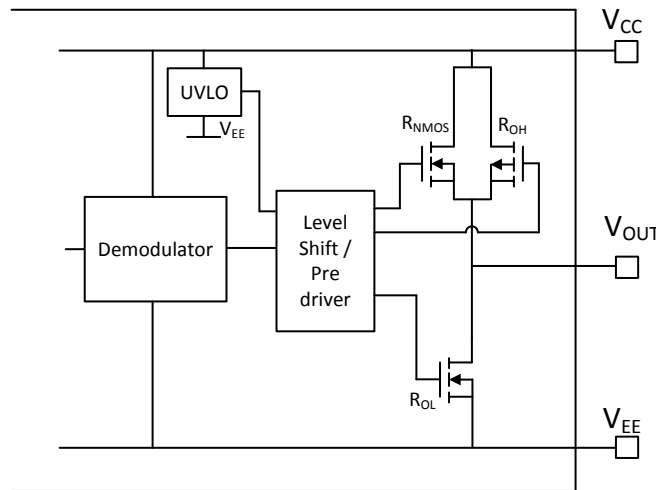

Figure 8-4. Output Stage

8.3.4 Protection Features

8.3.4.1 Undervoltage Lockout (UVLO)

UVLO function is implemented for V_{CC} and V_{EE} pins to prevent an under-driven condition on IGBTs and MOSFETs. When V_{CC} is lower than $UVLO_R$ at device start-up or lower than $UVLO_F$ after start-up, the voltage-supply UVLO feature holds the effected output low, regardless of the input forward current as shown in [Table 8-2](#). The V_{CC} UVLO protection has a hysteresis feature ($UVLO_{hys}$). This hysteresis prevents chatter when the power supply produces ground noise which allows the device to permit small drops in bias voltage, which occurs when the device starts switching and operating current consumption increases suddenly.

When V_{CC} drops below $UVLO_F$, a delay, t_{UVLO_rec} occurs on the output when the supply voltage rises above $UVLO_R$ again.

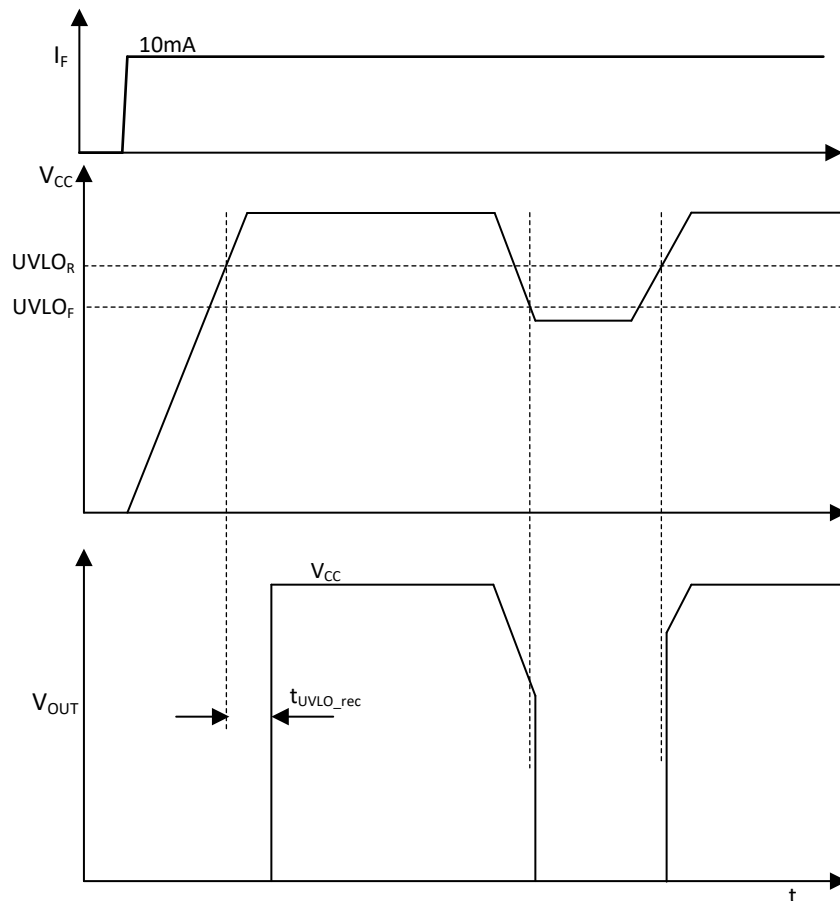

Figure 8-5. UVLO functionality

8.3.4.2 Active Pulldown

The active pull-down function is used to pull the IGBT or MOSFET gate to the low state when no power is connected to the V_{CC} supply. This feature prevents false IGBT and MOSFET turn-on by clamping V_{OUT} pin to approximately 2V.

When the output stage of the driver is in an unbiased condition (V_{CC} floating), the driver outputs (see [Figure 8-4](#)) are held low by an active clamp circuit that limits the voltage rise on the driver outputs. In this condition, the upper PMOS & NMOS are held off while the lower NMOS gate is tied to the driver output through an internal 500-k Ω resistor. In this configuration, the lower NMOS device effectively clamps the output (V_{OUT}) to less than 2V.

8.3.4.3 Short-Circuit Clamping

The short-circuit clamping function is used to clamp voltages at the driver output and pull the output pin V_{OUT} slightly higher than the V_{CC} voltage during short-circuit conditions. The short-circuit clamping function helps protect the IGBT or MOSFET gate from overvoltage breakdown or degradation. The short-circuit clamping function is implemented by adding a diode connection between the dedicated pins and the V_{CC} pin inside the driver. The internal diodes can conduct up to 500-mA current for a duration of 10 μ s and a continuous current of 20 mA. Use external Schottky diodes to improve current conduction capability as needed.

8.4 Device Functional Modes

Table 8-2 lists the functional modes for UCC23313

Table 8-2. Function Table for UCC23313 with VCC Rising

e-diode	VCC	V _{OUT}
OFF ($I_F < I_{FLH}$)	0V - 33V	Low
ON ($I_F > I_{FLH}$)	0V - UVLO _R	Low
ON ($I_F > I_{FLH}$)	UVLO _R - 33V	High

Table 8-3. Function Table for UCC23313 with VCC Falling

e-diode	VCC	V _{OUT}
OFF ($I_F < I_{FLH}$)	0V - 33V	Low
ON ($I_F > I_{FLH}$)	UVLO _F - 0V	Low
ON ($I_F > I_{FLH}$)	33V - UVLO _F	High

8.4.1 ESD Structure

Figure 8-6 shows the multiple diodes involved in the ESD protection components of the UCC23313 device. This provides pictorial representation of the absolute maximum rating for the device.

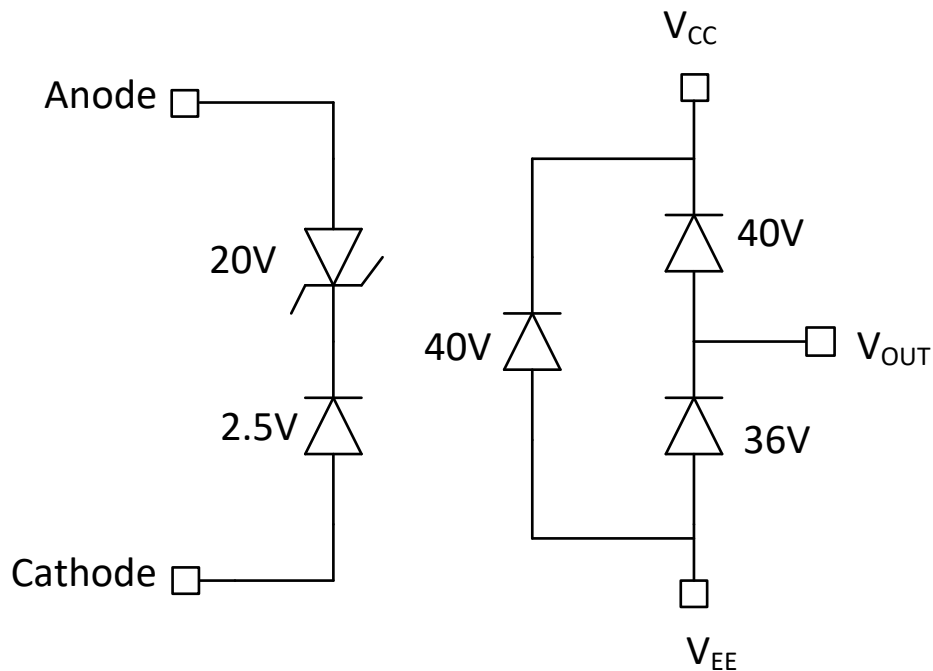

Figure 8-6. ESD Structure

9 Application and Implementation

Note

Information in the following applications sections is not part of the TI component specification, and TI does not warrant its accuracy or completeness. TI's customers are responsible for determining suitability of components for their purposes. Customers should validate and test their design implementation to confirm system functionality.

9.1 Application Information

UCC23313 is a single channel, isolated gate driver with opto-compatible input for power semiconductor devices, such as MOSFETs, IGBTs, or SiC MOSFETs. It is intended for use in applications such as motor control, industrial inverters, and switched-mode power supplies. It differs from standard opto isolated gate drivers as it does not have an LED input stage. Instead of an LED, it has an emulated diode (e-diode). To turn the e-diode "ON", a forward current in the range of 7mA to 16mA should be driven into the Anode. This will drive the gate driver output High and turn on the power FET. Typically, MCU's are not capable of providing the required forward current. Hence a buffer has to be used between the MCU and the input stage of UCC23313. Typical buffer power supplies are either 5V or 3.3V. A resistor is needed between the buffer and the input stage of UCC23313 to limit the current. It is simple, but important to choose the right value of resistance. The resistor tolerance, buffer supply voltage tolerance and output impedance of the buffer, have to be considered in the resistor selection. This will ensure that the e-diode forward current stays within the recommended range of 7mA to 16mA. Detailed design recommendations are given in the [Section 9.1](#). The current driven input stage offers excellent noise immunity that is need in high power motor drive systems, especially in cases where the MCU cannot be located close to the isolated gate driver. UCC23313 offers best in class CMTI performance of >150kV/us at 1500V common mode voltages.

The e-diode is capable of 25mA continuous in the forward direction. The forward voltage drop of the e-diode has a very tight part to part variation (1.8V min to 2.4V max). The temperature coefficient of the forward drop is <1.35mV/°C. The dynamic impedance of the e-diode in the forward biased region is ~1Ω. All of these factors contribute in excellent stability of the e-diode forward current. To turn the e-diode "OFF", the Anode - Cathode voltage should be <0.8V, or I_F should be < I_{FLH} . The e-diode can also be reverse biased up to 5V (7V abs max) in order to turn it off and bring the gate driver output low.

The output power supply for UCC23313 can be as high as 33V (35V abs max). The output power supply can be configured externally as a single isolated supply up to 33V or isolated bipolar supply such that $V_{CC}-V_{EE}$ does not exceed 33V, or it can be bootstrapped (with external diode & capacitor) if the system uses a single power supply with respect to the power ground. Typical quiescent power supply current from V_{CC} is 1.2mA (max 2.2mA).

9.2 Typical Application

The circuit in [Figure 9-1](#), shows a typical application for driving IGBTs.

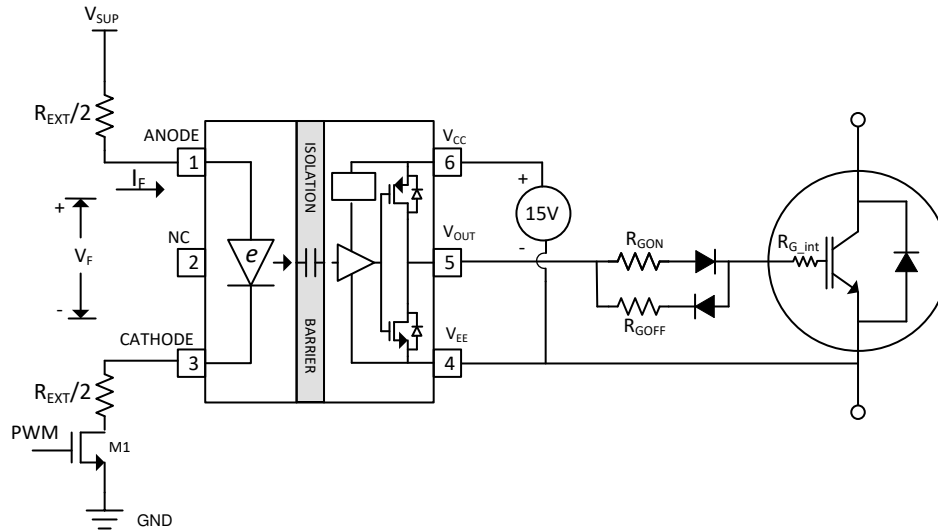

Figure 9-1. Typical Application Circuit for UCC23313 to Drive IGBT

9.2.1 Design Requirements

[Table 9-1](#) lists the recommended conditions to observe the input and output of the UCC23313 gate driver.

Table 9-1. UCC23313 Design Requirements

PARAMETER	VALUE	UNIT
V_{CC}	15	V
I_F	10	mA
Switching frequency	8	kHz

9.2.2 Detailed Design Procedure

9.2.2.1 Selecting the Input Resistor

The input resistor limits the current that flows into the e-diode when it is forward biased. The threshold current I_{FLH} is 2.8 mA typ. The recommended operating range for the forward current is 7 mA to 16 mA (e-diode ON). All the electrical specifications are guaranteed in this range. The resistor should be selected such that for typical operating conditions, I_F is 10 mA. Following are the list of factors that will affect the exact value of this current:

1. Supply Voltage V_{SUP} variation
2. Manufacturer's tolerance for the resistor and variation due to temperature
3. e-diode forward voltage drop variation (at $I_F=10$ mA, $V_F=$ typ 2.1 V, min 1.8 V, max 2.4 V, with a temperature coefficient < 1.35 mV/°C and dynamic impedance $< 1 \Omega$)

See [Figure 9-2](#) for the schematic using a single NMOS and split resistor combination to drive the input stage of UCC23313. The input resistor can be selected using the equation shown.

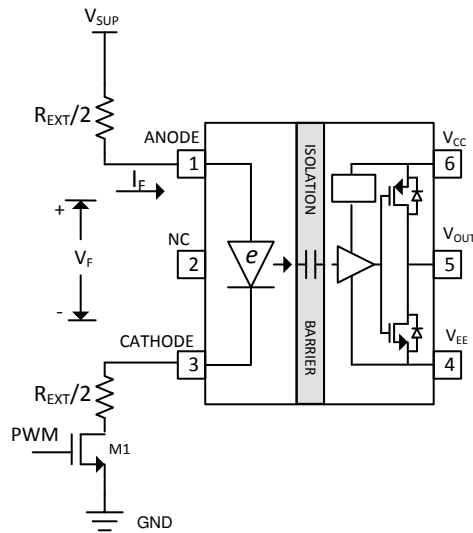

$$R_{EXT} = \frac{V_{SUP} - V_F}{I_F} - R_{M1}$$

Figure 9-2. Configuration 1: Driving the input stage of UCC23313 with a single NMOS and split resistors

Driving the input stage of UCC23313 using a single buffer is shown in [Figure 9-3](#) and using 2 buffers is shown in [Figure 9-4](#)

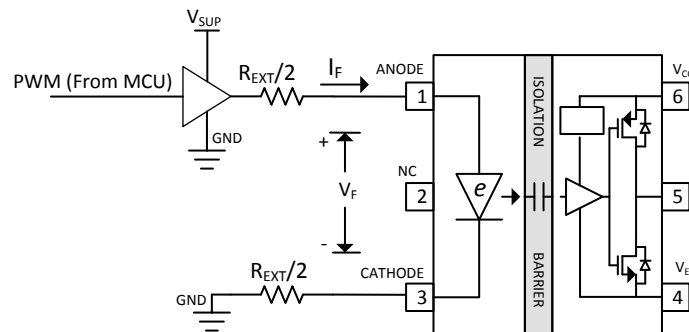

$$R_{EXT} = \frac{V_{SUP} - V_F}{I_F} - R_{OH_buf}$$

Figure 9-3. Configuration 2: Driving the input stage of UCC23313 with one Buffer and split resistors

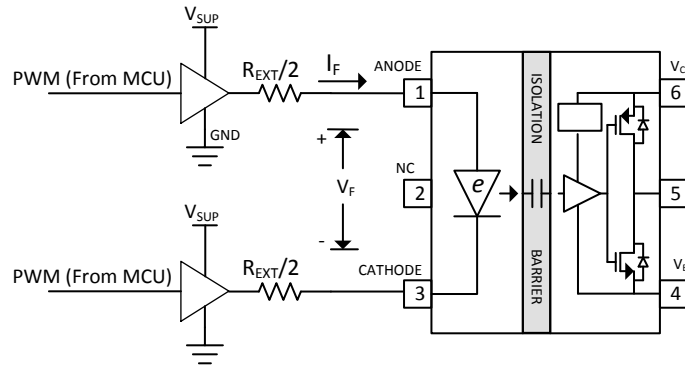

$$R_{EXT} = \frac{V_{SUP} - V_F}{I_F} - (R_{OH_buf} + R_{OL_buf})$$

Figure 9-4. Configuration 3: Driving the input stage of UCC23313 with 2 buffers and split resistors

Table 9-2 shows the range of values for R_{EXT} for the 3 different configurations shown in Figure 9-2, Figure 9-3 and Figure 9-4. The assumptions used in deriving the range for R_{EXT} are as follows:

1. Target forward current I_F is 7mA min, 10mA typ and 16mA max
2. e-diode forward voltage drop is 1.8V to 2.4V
3. V_{SUP} (Buffer supply voltage) is 5V with $\pm 5\%$ tolerance
4. Manufacturer's tolerance for R_{EXT} is 1%
5. NMOS resistance is 0.25 Ω to 1.0 Ω (for configuration 1)
6. R_{OH} (buffer output impedance in output "High" state) is 13 Ω min, 18 Ω typ and 22 Ω max
7. R_{OL} (buffer output impedance in "Low" state) is 10 Ω min, 14 Ω typ and 17 Ω max

Table 9-2. R_{EXT} Values to Drive The Input Stage

Configuration	$R_{EXT} \Omega$		
	Min	Typ	Max
Single NMOS and R_{EXT}	218	290	331
Single Buffer and R_{EXT}	204	272	311
Two Buffers and R_{EXT}	194	259	294

9.2.2.2 Gate Driver Output Resistor

The external gate-driver resistors, $R_{G(ON)}$ and $R_{G(OFF)}$ are used to:

1. Limit ringing caused by parasitic inductances and capacitances
2. Limit ringing caused by high voltage or high current switching dv/dt , di/dt , and body-diode reverse recovery
3. Fine-tune gate drive strength, specifically peak sink and source current to optimize the switching loss
4. Reduce electromagnetic interference (EMI)

The output stage has a pull up structure consisting of a P-channel MOSFET and an N-channel MOSFET in parallel. The combined peak source current is 4.5 A Use Equation 1 to estimate the peak source current as an example.

$$I_{OH} = \min \left[4.5A, \frac{V_{CC} - V_{GDF}}{(R_{NMOS} || R_{OH} + R_{GON} + R_{GFET_INT})} \right] \quad (1)$$

where

- R_{GON} is the external turnon resistance.
- R_{GFET_Int} is the power transistor internal gate resistance, found in the power transistor data sheet. We will assume 0Ω for our example
- I_{OH} is the peak source current which is the minimum value between 4.5A, the gate-driver peak source current, and the calculated value based on the gate-drive loop resistance.
- V_{GDF} is the forward voltage drop for each of the diodes in series with R_{GON} and R_{GOFF} . The diode drop for this example is 0.7 V.

In this example, the peak source current is approximately 1.7A as calculated in [Equation 2](#).

$$I_{OH} = \min \left[4.5A, \frac{15 - 0.7}{(5.1\Omega || 9.5\Omega + 5\Omega + 0\Omega)} \right] = 1.72A \quad (3)$$

Similarly, use [Equation 3](#) to calculate the peak sink current.

$$I_{OL} = \min \left[5.3A, \frac{V_{CC} - V_{GDF}}{(R_{OL} + R_{GOFF} + R_{GFET_INT})} \right] \quad (4)$$

where

- R_{GOFF} is the external turnoff resistance.
- I_{OL} is the peak sink current which is the minimum value between 5.3A, the gate-driver peak sink current, and the calculated value based on the gate-drive loop resistance.

In this example, the peak sink current is the minimum of [Equation 4](#) and 1.38A.

$$I_{OL} = \min \left[5.3A, \frac{15 - 0.7}{(0.4\Omega + 10\Omega + 0\Omega)} \right] = 1.38A \quad (5)$$

The diodes shown in series with each, R_{GON} and R_{GOFF} , in [Figure 9-1](#) ensure the gate drive current flows through the intended path, respectively, during turn-on and turn-off. Note that the diode forward drop will reduce the voltage level at the gate of the power switch. To achieve rail-to-rail gate voltage levels, add a resistor from the V_{OUT} pin to the power switch gate, with a resistance value approximately 20 times higher than R_{GON} and R_{GOFF} . For the examples described in this section, a good choice is 100 Ω to 200 Ω .

Note

The estimated peak current is also influenced by PCB layout and load capacitance. Parasitic inductance in the gate-driver loop can slow down the peak gate-drive current and introduce overshoot and undershoot. Therefore, TI strongly recommends that the gate-driver loop should be minimized. Conversely, the peak source and sink current is dominated by loop parasitics when the load capacitance (C_{ISS}) of the power transistor is very small (typically less than 1 nF) because the rising and falling time is too small and close to the parasitic ringing period.

9.2.2.3 Estimate Gate-Driver Power Loss

The total loss, P_G , in the gate-driver subsystem includes the power losses (P_{GD}) of the UCC23313 device and the power losses in the peripheral circuitry, such as the external gate-drive resistor.

The P_{GD} value is the key power loss which determines the thermal safety-related limits of the UCC23313 device, and it can be estimated by calculating losses from several components.

The first component is the static power loss, P_{GDQ} , which includes power dissipated in the input stage (P_{GDQ_IN}) as well as the quiescent power dissipated in the output stage (P_{GDQ_OUT}) when operating with a certain switching frequency under no load. P_{GDQ_IN} is determined by I_F and \bar{V}_F and is given by [Equation 5](#). The

P_{GDQ_OUT} parameter is measured on the bench with no load connected to V_{OUT} pin at a given V_{CC} , switching frequency, and ambient temperature. In this example, V_{CC} is 15 V. The current on the power supply, with PWM switching at 10 kHz, is measured to be $I_{CC} = 1.33$ mA. Therefore, use Equation 6 to calculate P_{GDQ_OUT} .

$$P_{GDQ_IN} = \frac{1}{2} * V_F * I_F \tag{6}$$

$$P_{GDQ_OUT} = V_{CC} * I_{CC} \tag{7}$$

The total quiescent power (without any load capacitance) dissipated in the gate driver is given by the sum of Equation 5 and Equation 6 as shown in Equation 7

$$P_{GDQ} = P_{GDQ_IN} + P_{GDQ_OUT} = 10 \text{ mW} + 20\text{mW} = 30\text{mW} \tag{8}$$

The second component is the switching operation loss, P_{GDSW} , with a given load capacitance which the driver charges and discharges the load during each switching cycle. Use Equation 8 to calculate the total dynamic loss from load switching, P_{GSW} .

$$P_{GSW} = V_{CC2} \times Q_G \times f_{SW} \tag{9}$$

where

- Q_G is the gate charge of the power transistor at V_{CC} .

So, for this example application the total dynamic loss from load switching is approximately 18 mW as calculated in Equation 9.

$$P_{GSW} = 15 \text{ V} \times 120 \text{ nC} \times 10 \text{ kHz} = 18 \text{ mW} \tag{10}$$

Q_G represents the total gate charge of the power transistor switching 520 V at 50 A, and is subject to change with different testing conditions. The UCC23313 gate-driver loss on the output stage, P_{GDO} , is part of P_{GSW} . P_{GDO} is equal to P_{GSW} if the external gate-driver resistance and power-transistor internal resistance are 0 Ω , and all the gate driver-loss will be dissipated inside the UCC23313. If an external turn-on and turn-off resistance exists, the total loss is distributed between the gate driver pull-up/down resistance, external gate resistance, and power-transistor internal resistance. Importantly, the pull-up/down resistance is a linear and fixed resistance if the source/sink current is not saturated to 4.5A/5.3A, however, it will be non-linear if the source/sink current is saturated. Therefore, P_{GDO} is different in these two scenarios.

Case 1 - Linear Pull-Up/Down Resistor:

$$P_{GDO} = \frac{P_{GSW}}{2} \left[\frac{R_{OH} || R_{NMOS}}{R_{OH} || R_{NMOS} + R_{GON} + R_{GFET_int}} + \frac{R_{OL}}{R_{OL} + R_{GOFF} + R_{GFET_int}} \right] \tag{11}$$

In this design example, all the predicted source and sink currents are less than 4.5 A and 5.3 A, therefore, use Equation 10 to estimate the UCC23313 gate-driver loss.

$$P_{GDO} = \frac{18 \text{ mW}}{2} \left[\frac{9.5\Omega || 5.1\Omega}{9.5\Omega || 5.1\Omega + 5.1\Omega + 0\Omega} + \frac{0.4\Omega}{0.4\Omega + 10\Omega + 0\Omega} \right] = 3.9 \text{ mW} \tag{12}$$

Case 2 - Nonlinear Pull-Up/Down Resistor:

$$P_{GDO} = f_{sw} \times \left[4.5A \times \int_0^{T_{R_Sys}} (V_{CC} - V_{OUT}(t)) dt + 5.3A \times \int_0^{T_{F_Sys}} V_{OUT}(t) dt \right] \quad (13)$$

where

- $V_{OUT}(t)$ is the gate-driver OUT pin voltage during the turnon and turnoff period. In cases where the output is saturated for some time, this value can be simplified as a constant-current source (4.5 A at turnon and 5.3 A at turnoff) charging or discharging a load capacitor. Then, the $V_{OUT}(t)$ waveform will be linear and the T_{R_Sys} and T_{F_Sys} can be easily predicted.

For some scenarios, if only one of the pullup or pulldown circuits is saturated and another one is not, the P_{GDO} is a combination of case 1 and case 2, and the equations can be easily identified for the pullup and pulldown based on this discussion.

Use [Equation 13](#) to calculate the total gate-driver loss dissipated in the UCC23313 gate driver, P_{GD} .

$$P_{GD} = P_{GDQ} + P_{GDO} = 30mW + 3.9mW = 33.9mW \quad (14)$$

9.2.2.4 Estimating Junction Temperature

Use [Equation 14](#) to estimate the junction temperature (T_J) of UCC23313.

$$T_J = T_C + \Psi_{JT} \times P_{GD} \quad (15)$$

where

- T_C is the UCC23313 case-top temperature measured with a thermocouple or some other instrument.
- Ψ_{JT} is the junction-to-top characterization parameter from the table.

Using the junction-to-top characterization parameter (Ψ_{JT}) instead of the junction-to-case thermal resistance ($R_{\theta JC}$) can greatly improve the accuracy of the junction temperature estimation. The majority of the thermal energy of most ICs is released into the PCB through the package leads, whereas only a small percentage of the total energy is released through the top of the case (where thermocouple measurements are usually conducted). The $R_{\theta JC}$ resistance can only be used effectively when most of the thermal energy is released through the case, such as with metal packages or when a heat sink is applied to an IC package. In all other cases, use of $R_{\theta JC}$ will inaccurately estimate the true junction temperature. The Ψ_{JT} parameter is experimentally derived by assuming that the dominant energy leaving through the top of the IC will be similar in both the testing environment and the application environment. As long as the recommended layout guidelines are observed, junction temperature estimations can be made accurately to within a few degrees Celsius.

9.2.2.5 Selecting V_{CC} Capacitor

Bypass capacitors for V_{CC} is essential for achieving reliable performance. TI recommends choosing low-ESR and low-ESL, surface-mount, multi-layer ceramic capacitors (MLCC) with sufficient voltage ratings, temperature coefficients, and capacitance tolerances. A 50-V, 10- μ F MLCC and a 50-V, 0.22- μ F MLCC are selected for the C_{VCC} capacitor. If the bias power supply output is located a relatively long distance from the V_{CC} pin, a tantalum or electrolytic capacitor with a value greater than 10 μ F should be used in parallel with C_{VCC} .

Note

DC bias on some MLCCs will impact the actual capacitance value. For example, a 25-V, 1- μ F X7R capacitor is measured to be only 500 nF when a DC bias of 15- V_{DC} is applied.

10 Power Supply Recommendations

The recommended input supply voltage (V_{CC}) for the UCC23313 device is from 10 V or 14 V to 33 V. The lower limit of the range of output bias-supply voltage (V_{CC}) is determined by the internal UVLO protection feature of the device. V_{CC} voltage should not fall below the UVLO threshold for normal operation, or else the gate-driver outputs can become clamped low for more than 20 μ s by the UVLO protection feature. The higher limit of the V_{CC} range depends on the maximum gate voltage of the power device that is driven by the UCC23313 device, and should not exceed the recommended maximum V_{CC} of 33 V. A local bypass capacitor should be placed between the V_{CC} and V_{EE} pins, with a value of 220-nF to 10- μ F for device biasing. TI recommends placing an additional 100-nF capacitor in parallel with the device biasing capacitor for high frequency filtering. Both capacitors should be positioned as close to the device as possible. Low-ESR, ceramic surface-mount capacitors are recommended.

If only a single, primary-side power supply is available in an application, isolated power can be generated for the secondary side with the help of a transformer driver such as Texas Instruments' [SN6501](#) or [SN6505A](#). For such applications, detailed power supply design and transformer selection recommendations are available in [SN6501 Transformer Driver for Isolated Power Supplies data sheet](#) and [SN6505A Low-Noise 1-A Transformer Drivers for Isolated Power Supplies data sheet](#).

11 Layout

11.1 Layout Guidelines

Designers must pay close attention to PCB layout to achieve optimum performance for the UCC23313. Some key guidelines are:

- Component placement:
 - Low-ESR and low-ESL capacitors must be connected close to the device between the V_{CC} and V_{EE} pins to bypass noise and to support high peak currents when turning on the external power transistor.
 - To avoid large negative transients on the V_{EE} pins connected to the switch node, the parasitic inductances between the source of the top transistor and the source of the bottom transistor must be minimized.
- Grounding considerations:
 - Limiting the high peak currents that charge and discharge the transistor gates to a minimal physical area is essential. This limitation decreases the loop inductance and minimizes noise on the gate terminals of the transistors. The gate driver must be placed as close as possible to the transistors.
- High-voltage considerations:
 - To ensure isolation performance between the primary and secondary side, avoid placing any PCB traces or copper below the driver device. A PCB cutout or groove is recommended in order to prevent contamination that may compromise the isolation performance.
- Thermal considerations:
 - A large amount of power may be dissipated by the UCC23313 if the driving voltage is high, the load is heavy, or the switching frequency is high. Proper PCB layout can help dissipate heat from the device to the PCB and minimize junction-to-board thermal impedance (θ_{JB}).
 - Increasing the PCB copper connecting to the V_{CC} and V_{EE} pins is recommended, with priority on maximizing the connection to V_{EE} . However, the previously mentioned high-voltage PCB considerations must be maintained.
 - If the system has multiple layers, TI also recommends connecting the V_{CC} and V_{EE} pins to internal ground or power planes through multiple vias of adequate size. These vias should be located close to the IC pins to maximize thermal conductivity. However, keep in mind that no traces or coppers from different high voltage planes are overlapping.

11.2 Layout Example

Figure 11-1 shows a PCB layout example with the signals and key components labeled.

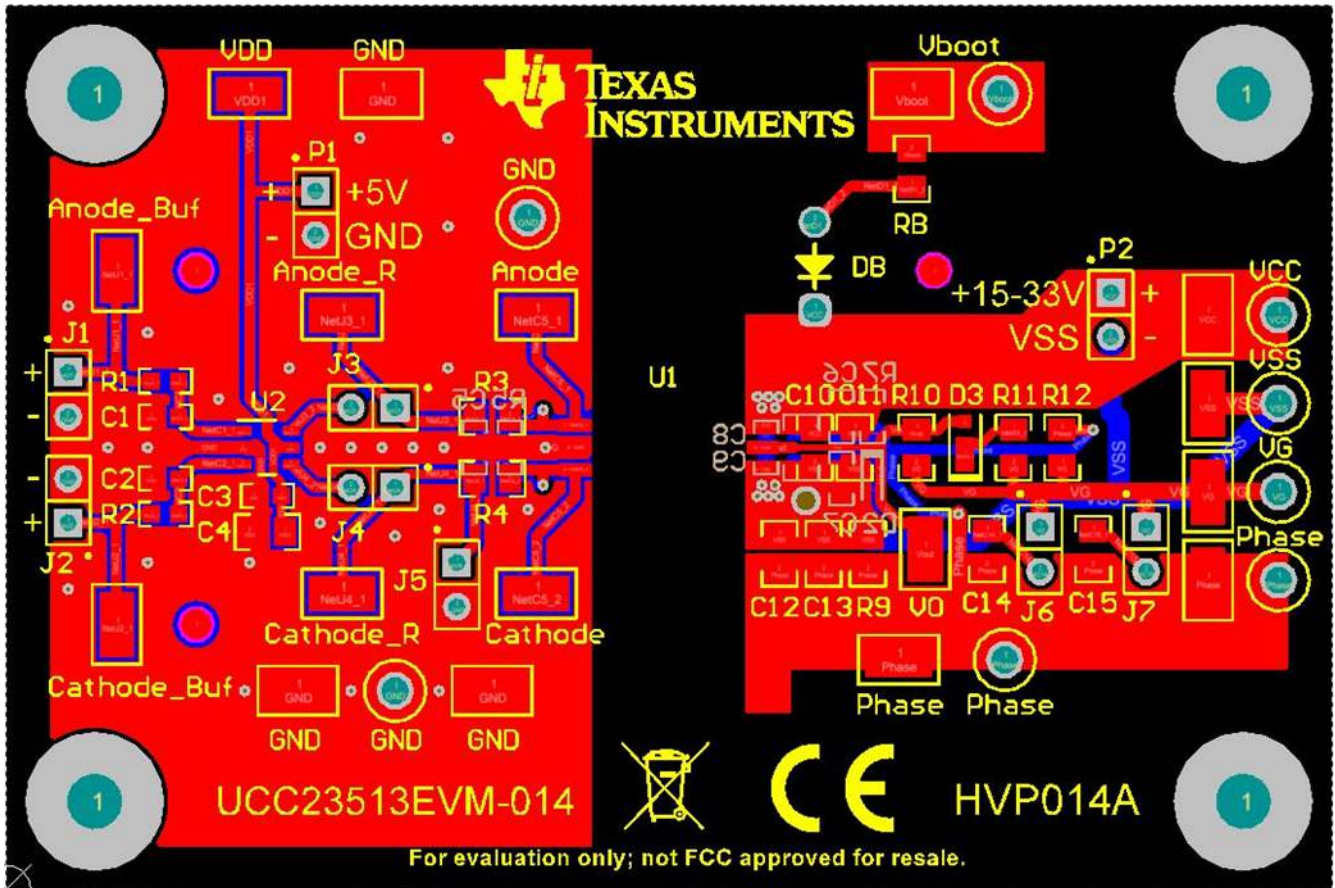

A. No PCB traces or copper are located between the primary and secondary side, which ensures isolation performance.

Figure 11-1. Layout Example

Figure 11-2 and Figure 11-3 show the top and bottom layer traces and copper.

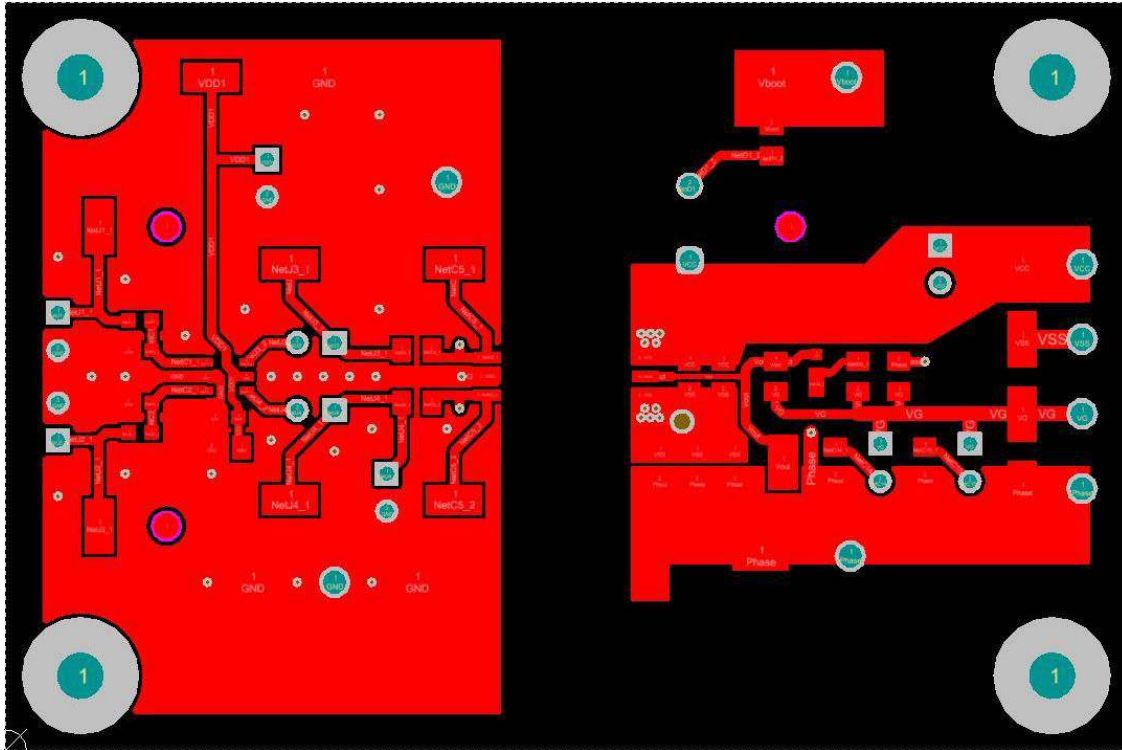

Figure 11-2. Top-Layer Traces and Copper

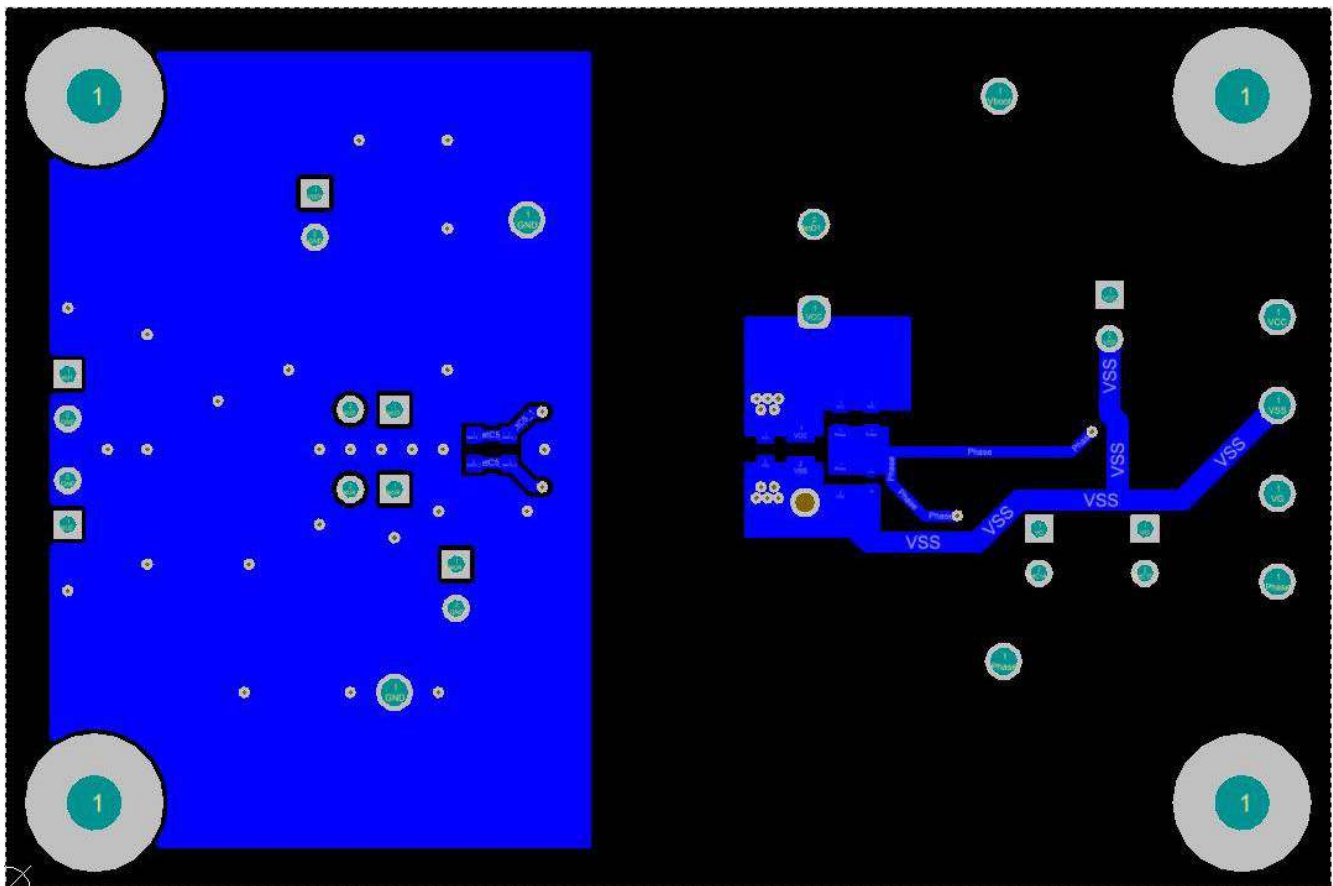
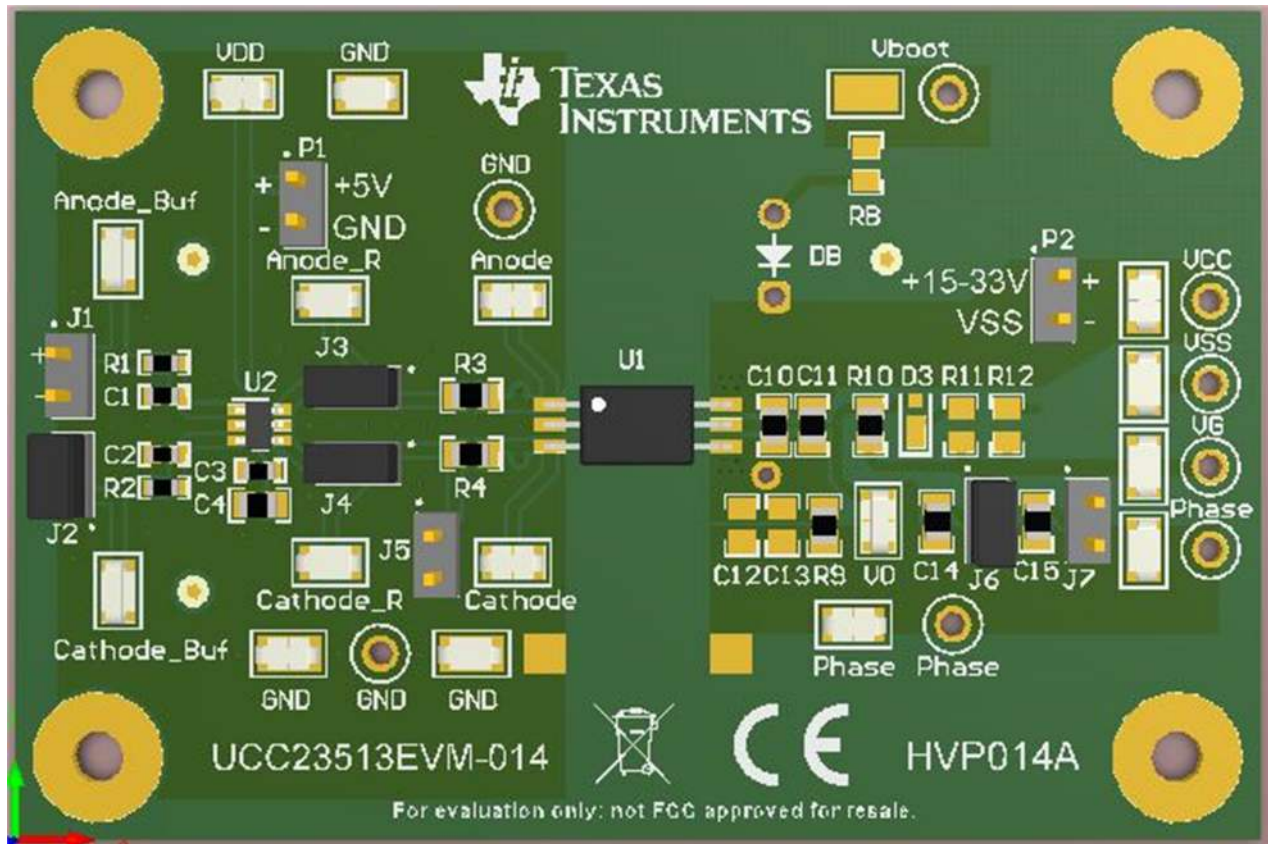

Figure 11-3. Bottom-Layer Traces and Copper (Flipped)

Figure 11-4 shows the 3D layout of the top view of the PCB.



A. The location of the PCB cutout between primary side and secondary sides ensures isolation performance.

Figure 11-4. 3-D PCB View

11.3 PCB Material

Use standard FR-4 UL94V-0 printed circuit board. This PCB is preferred over cheaper alternatives because of lower dielectric losses at high frequencies, less moisture absorption, greater strength and stiffness, and the self-extinguishing flammability-characteristics.

12 Mechanical, Packaging, and Orderable Information

The following pages include mechanical, packaging, and orderable information. This information is the most current data available for the designated devices. This data is subject to change without notice and revision of this document. For browser-based versions of this data sheet, refer to the left-hand navigation.

PACKAGING INFORMATION

Orderable Device	Status (1)	Package Type	Package Drawing	Pins	Package Qty	Eco Plan (2)	Lead finish/ Ball material (6)	MSL Peak Temp (3)	Op Temp (°C)	Device Marking (4/5)	Samples
UCC23313BDWY	ACTIVE	SOIC	DWY	6	100	RoHS & Green	NIPDAU	Level-2-260C-1 YEAR	-40 to 125	UC23313B	Samples
UCC23313BDWYR	ACTIVE	SOIC	DWY	6	850	RoHS & Green	NIPDAU	Level-2-260C-1 YEAR	-40 to 125	UC23313B	Samples
UCC23313DWY	ACTIVE	SOIC	DWY	6	100	RoHS & Green	NIPDAU	Level-2-260C-1 YEAR	-40 to 125	UCC23313	Samples
UCC23313DWYR	ACTIVE	SOIC	DWY	6	850	RoHS & Green	NIPDAU	Level-2-260C-1 YEAR	-40 to 125	UCC23313	Samples

(1) The marketing status values are defined as follows:

ACTIVE: Product device recommended for new designs.

LIFEBUY: TI has announced that the device will be discontinued, and a lifetime-buy period is in effect.

NRND: Not recommended for new designs. Device is in production to support existing customers, but TI does not recommend using this part in a new design.

PREVIEW: Device has been announced but is not in production. Samples may or may not be available.

OBSOLETE: TI has discontinued the production of the device.

(2) **RoHS:** TI defines "RoHS" to mean semiconductor products that are compliant with the current EU RoHS requirements for all 10 RoHS substances, including the requirement that RoHS substance do not exceed 0.1% by weight in homogeneous materials. Where designed to be soldered at high temperatures, "RoHS" products are suitable for use in specified lead-free processes. TI may reference these types of products as "Pb-Free".

RoHS Exempt: TI defines "RoHS Exempt" to mean products that contain lead but are compliant with EU RoHS pursuant to a specific EU RoHS exemption.

Green: TI defines "Green" to mean the content of Chlorine (Cl) and Bromine (Br) based flame retardants meet JS709B low halogen requirements of <=1000ppm threshold. Antimony trioxide based flame retardants must also meet the <=1000ppm threshold requirement.

(3) **MSL, Peak Temp.** - The Moisture Sensitivity Level rating according to the JEDEC industry standard classifications, and peak solder temperature.

(4) There may be additional marking, which relates to the logo, the lot trace code information, or the environmental category on the device.

(5) Multiple Device Markings will be inside parentheses. Only one Device Marking contained in parentheses and separated by a "-" will appear on a device. If a line is indented then it is a continuation of the previous line and the two combined represent the entire Device Marking for that device.

(6) **Lead finish/Ball material** - Orderable Devices may have multiple material finish options. Finish options are separated by a vertical ruled line. Lead finish/Ball material values may wrap to two lines if the finish value exceeds the maximum column width.

Important Information and Disclaimer: The information provided on this page represents TI's knowledge and belief as of the date that it is provided. TI bases its knowledge and belief on information provided by third parties, and makes no representation or warranty as to the accuracy of such information. Efforts are underway to better integrate information from third parties. TI has taken and

continues to take reasonable steps to provide representative and accurate information but may not have conducted destructive testing or chemical analysis on incoming materials and chemicals. TI and TI suppliers consider certain information to be proprietary, and thus CAS numbers and other limited information may not be available for release.

In no event shall TI's liability arising out of such information exceed the total purchase price of the TI part(s) at issue in this document sold by TI to Customer on an annual basis.

OTHER QUALIFIED VERSIONS OF UCC23313 :

- Automotive: [UCC23313-Q1](#)

NOTE: Qualified Version Definitions:

- Automotive - Q100 devices qualified for high-reliability automotive applications targeting zero defects

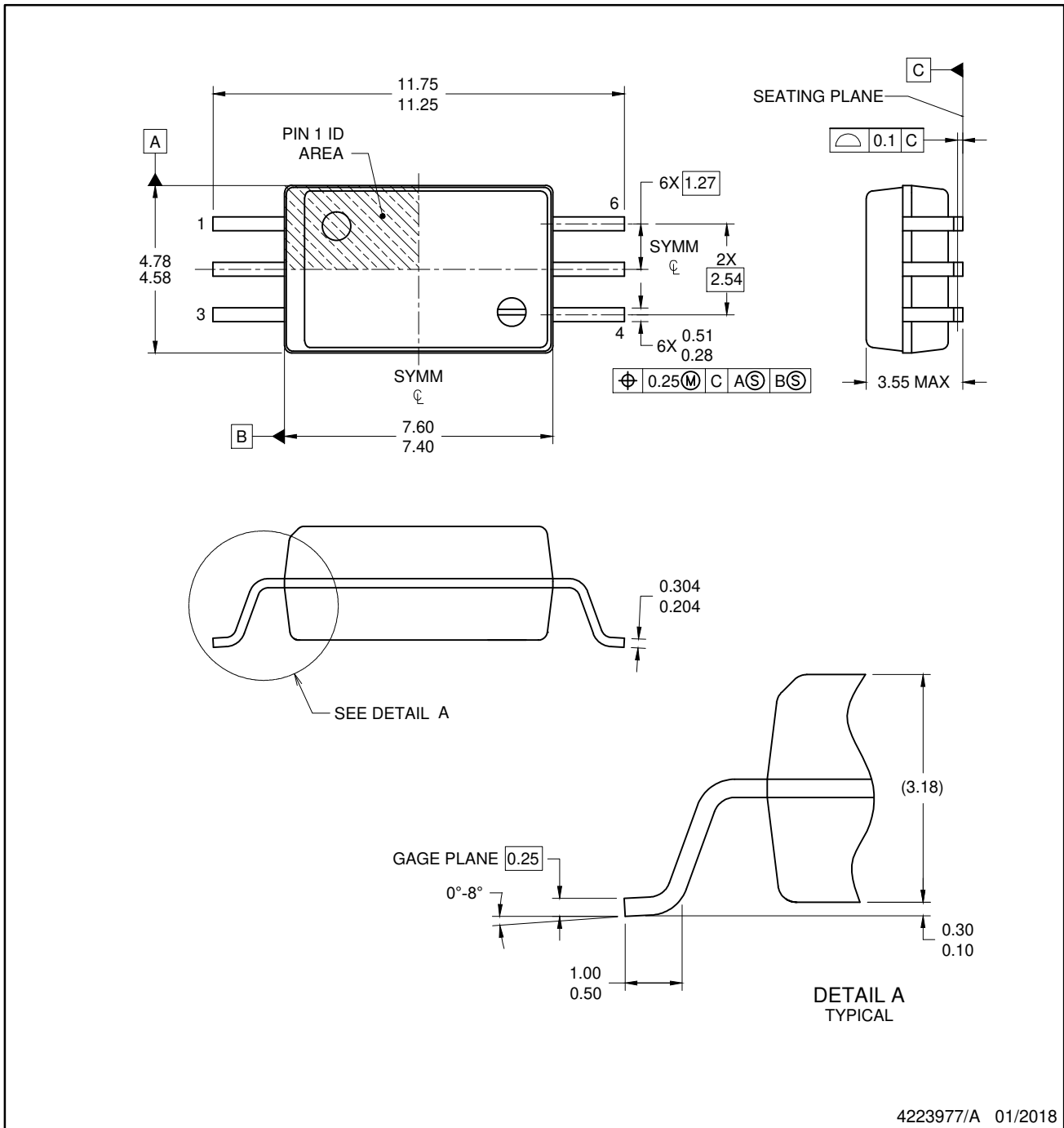

4223977/A 01/2018

NOTES:

1. All linear dimensions are in millimeters. Any dimensions in parenthesis are for reference only. Dimensioning and tolerancing per ASME Y14.5M.
2. This drawing is subject to change without notice.
3. This dimension does not include mold flash, protrusions, or gate burrs. Mold flash, protrusions, or gate burrs shall not exceed 0.15 per side.
4. This dimension does not include interlead flash. Interlead flash shall not exceed 0.70 per side.

EXAMPLE BOARD LAYOUT

SOIC - 3.55 mm max height

DWY0006A

SOIC

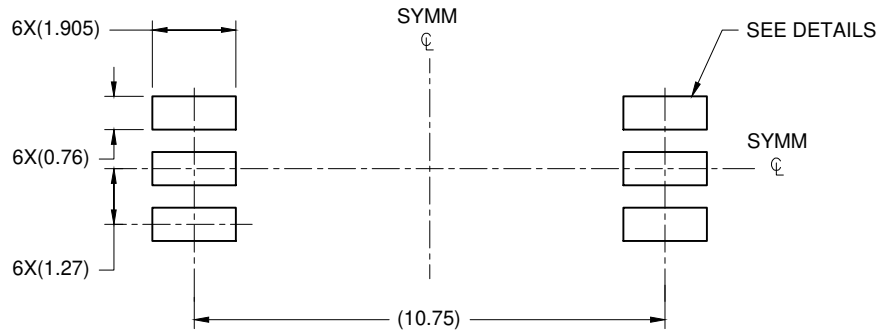

LAND PATTERN EXAMPLE
SCALE:6X

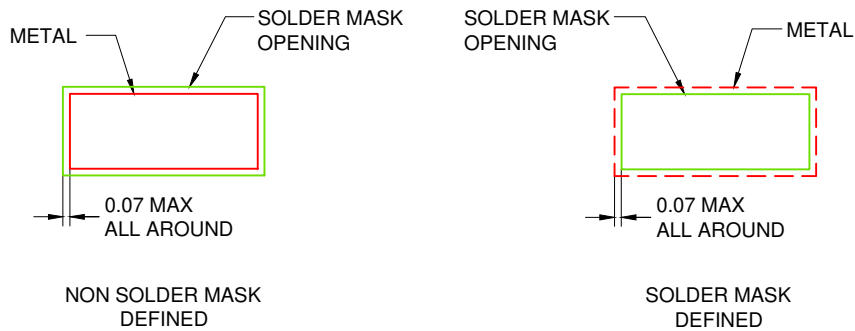

SOLDER MASK DETAILS

4223977/A 01/2018

NOTES: (continued)

5. Publication IPC-7351 may have alternate designs.
6. Solder mask tolerances between and around signal pads can vary based on board fabrication site.

EXAMPLE STENCIL DESIGN

SOIC - 3.55 mm max height

DWY0006A

SOIC

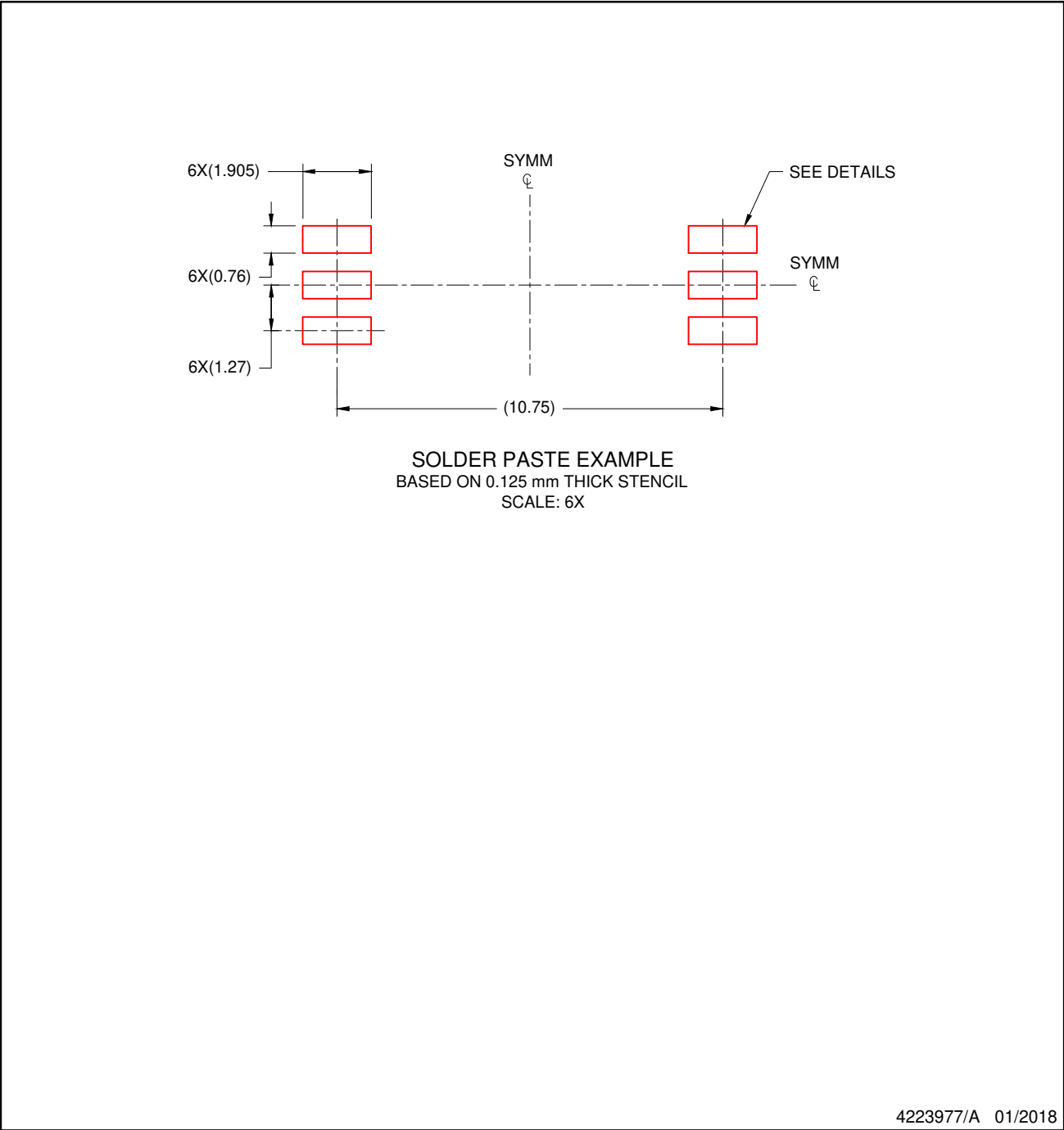

NOTES: (continued)

- 7. Laser cutting apertures with trapezoidal walls and rounded corners may offer better paste release. IPC-7525 may have alternate design recommendations.
- 8. Board assembly site may have different recommendations for stencil design.

IMPORTANT NOTICE AND DISCLAIMER

TI PROVIDES TECHNICAL AND RELIABILITY DATA (INCLUDING DATASHEETS), DESIGN RESOURCES (INCLUDING REFERENCE DESIGNS), APPLICATION OR OTHER DESIGN ADVICE, WEB TOOLS, SAFETY INFORMATION, AND OTHER RESOURCES "AS IS" AND WITH ALL FAULTS, AND DISCLAIMS ALL WARRANTIES, EXPRESS AND IMPLIED, INCLUDING WITHOUT LIMITATION ANY IMPLIED WARRANTIES OF MERCHANTABILITY, FITNESS FOR A PARTICULAR PURPOSE OR NON-INFRINGEMENT OF THIRD PARTY INTELLECTUAL PROPERTY RIGHTS.

These resources are intended for skilled developers designing with TI products. You are solely responsible for (1) selecting the appropriate TI products for your application, (2) designing, validating and testing your application, and (3) ensuring your application meets applicable standards, and any other safety, security, or other requirements. These resources are subject to change without notice. TI grants you permission to use these resources only for development of an application that uses the TI products described in the resource. Other reproduction and display of these resources is prohibited. No license is granted to any other TI intellectual property right or to any third party intellectual property right. TI disclaims responsibility for, and you will fully indemnify TI and its representatives against, any claims, damages, costs, losses, and liabilities arising out of your use of these resources.

TI's products are provided subject to TI's Terms of Sale (<https://www.ti.com/legal/termsofsale.html>) or other applicable terms available either on [ti.com](https://www.ti.com) or provided in conjunction with such TI products. TI's provision of these resources does not expand or otherwise alter TI's applicable warranties or warranty disclaimers for TI products.

Mailing Address: Texas Instruments, Post Office Box 655303, Dallas, Texas 75265
Copyright © 2021, Texas Instruments Incorporated