

NOTE : (2) POLARIZATION PEGS ARE SHOWN. HOWEVER, ASSEMBLIES MAY BE MANUFACTURED WITH (1) PEG ONLY.

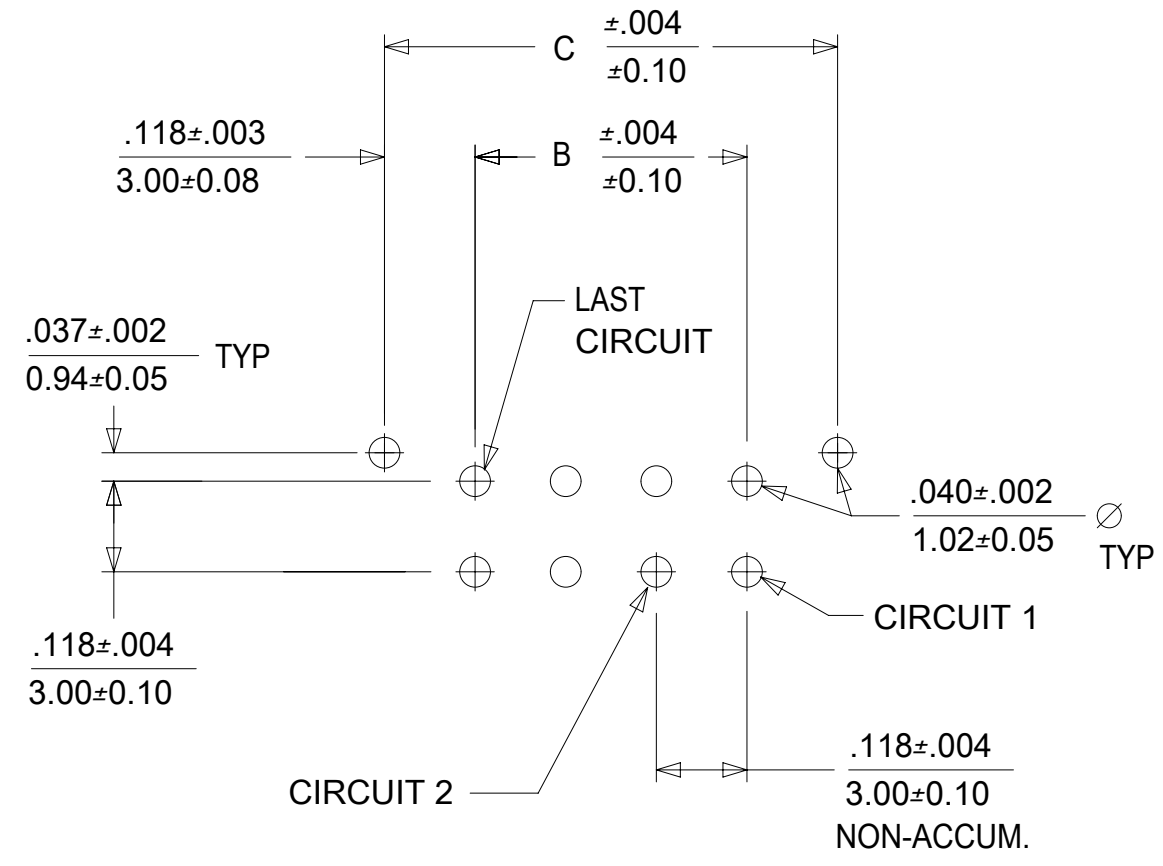
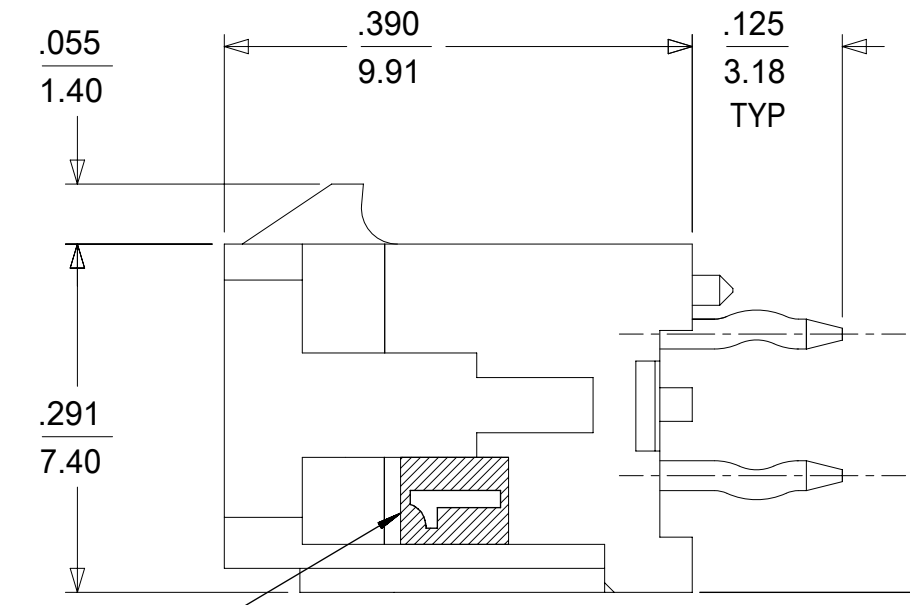
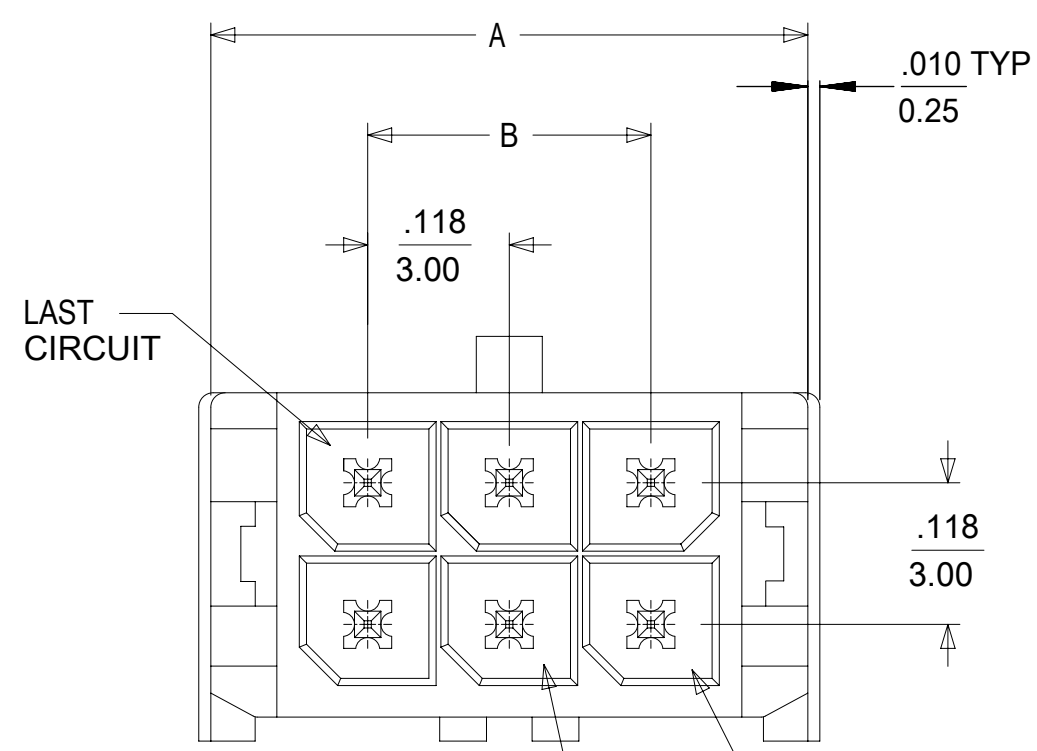

PCB LAYOUT: COMPONENT SIDE
RECOMMEND PCB THICKNESS: .062/1.57

CKTS	A	B	C
02	.262 6.65	NA	.236 6.00
04	.380 9.65	.118 3.00	.354 9.00
06	.498 12.65	.236 6.00	.472 12.00
08	.616 15.65	.354 9.00	.591 15.00
10	.734 18.65	.472 12.00	.709 18.00
12	.852 21.65	.591 15.00	.827 21.00
14	.970 24.65	.709 18.00	.945 24.00
16	1.088 27.65	.827 21.00	1.063 27.00
18	1.206 30.65	.945 24.00	1.181 30.00
20	1.325 33.65	1.063 27.00	1.299 33.00
22	1.443 36.65	1.181 30.00	1.417 36.00
24	1.561 39.65	1.299 33.00	1.535 39.00

NOTES:

- HOUSING MATERIAL: GLASS FILLED LIQUID CRYSTAL POLYMER, UL94V-0, COLOR: BLACK
TERMINAL MATERIAL: BRASS ALLOY
- FINISH: A = .000060/(0.00152) MIN. REFLOWED MATTE TIN OVER .000050/(0.00127) MIN. NICKEL PLATE. (FINISH IS BRIGHT IN APPEARANCE, THICKNESS AS APPLIED PRIOR TO REFLOW)
B = .000015/(0.00038) MIN. SELECT GOLD IN CONTACT AREA; .000100/(0.00254) MIN. SELECT MATTE TIN ON SOLDER TAILS; BOTH OVER .000050/(0.00127) MIN. NICKEL PLATE.
C = .000030/(0.00076) MIN. SELECT GOLD IN CONTACT AREA; .000100/(0.00254) MIN. SELECT MATTE TIN ON SOLDER TAILS; BOTH OVER .000050/(0.00127) MIN. NICKEL PLATE.
- PRODUCT SPECIFICATION: PS-43045
- PACKAGING: TAPE & REEL (WITH DISPOSABLE CAPS) PER 430450008-PK.
- MATES WITH MICRO FIT (3.0) RECEPTACLE SERIES 43025
- THIS PART CONFORMS TO CLASS B REQUIREMENTS OF COSMETIC SPECIFICATION PS-45499-002.
- CIRCUIT SIZES 2-6: "D" IS .265/6.74 FOR .010/0.25 STEP
CIRCUIT SIZES 8-24: "D" IS .063/1.60 FOR .010/0.25 STEP.
- TEXT ON PART IS FOR REFERENCE ONLY. TEXT AND TEXT LOCATION MAY VARY DEPENDING ON PART NUMBER AND/OR TOOL.

CIRCUIT "1" IDENTIFIED ON THIS SURFACE (APPROX. LOCATION SHOWN FOR REF.)

CKTS	TOOLED	FINISH A MATERIAL NO:	FINISH B MATERIAL NO:	FINISH C MATERIAL NO:
02	YES	43045-0283	43045-0284	43045-0285
04	YES	43045-0483	43045-0484	43045-0485
06	YES	43045-0683	43045-0684	43045-0685
08	YES	43045-0883	43045-0884	43045-0885
10	YES	43045-1083	43045-1084	43045-1085
12	YES	43045-1283	43045-1284	43045-1285
14	YES	43045-1483	43045-1484	43045-1485
16	YES	43045-1683	43045-1684	43045-1685
18	YES	43045-1883	43045-1884	43045-1885
20	YES	43045-2083	43045-2084	43045-2085
22	NO	43045-2283	43045-2284	43045-2285
24	YES	43045-2483	43045-2484	43045-2485

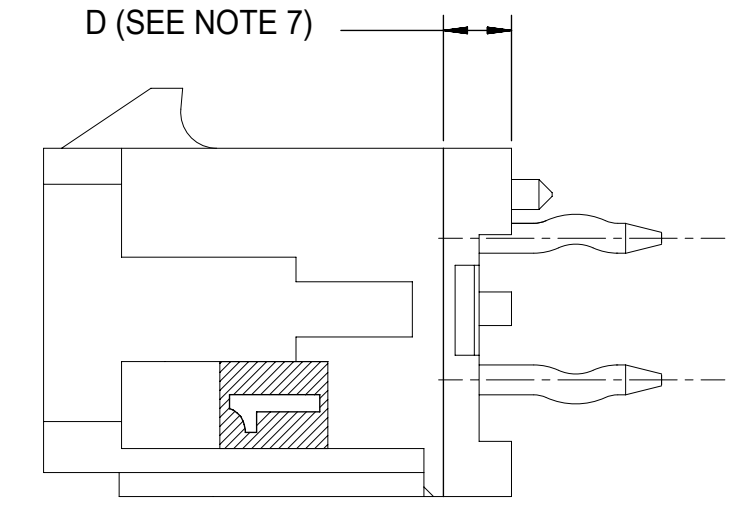

SHOWN WITH DISPOSABLE CAP
SEE NOTE 4

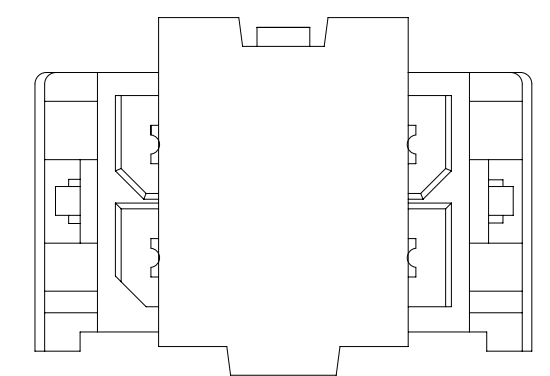

SYMBOLS		THIS DRAWING CONTAINS INFORMATION THAT IS PROPRIETARY TO MOLEX ELECTRONIC TECHNOLOGIES, LLC AND SHOULD NOT BE USED WITHOUT WRITTEN PERMISSION		CURRENT REV DESC: MICROFIT PK SPEC				
▽ = 0	IN/MM	SCALE	NTS	REF				
▽ = 0	GENERAL TOLERANCES (UNLESS SPECIFIED)		EC NO: 611607					
▽ = 0	MM	INCH	DRWN: SALHAMY	2018/12/28				
▽ = 0	4 PLACES ±	±	CHK'D: SSOUSEK	2019/08/09				
▽ = 0	3 PLACES ±	± 0.01	APPR: FSMITH	2019/08/15	PRODUCT CUSTOMER DRAWING			
▽ = 0	2 PLACES ±	± 0.014	INITIAL REVISION:					
▽ = 0	1 PLACE ±	± 0.36	DRWN: TRBENES	2009/02/16	DOCUMENT NUMBER	DOC TYPE	DOC PART	REVISION
▽ = 0	0 PLACES ±	±	APPR: FSMITH	2009/02/16	SD-43045-030	PSD	001	B6
▽ = 0	ANGULAR TOL ±	± 0.5 °	THIRD ANGLE PROJECTION		MATERIAL NUMBER	CUSTOMER	SHEET NUMBER	
▽ = 0	DRAFT WHERE APPLICABLE MUST REMAIN WITHIN DIMENSIONS		C-SIZE	43045	SEE CHART	GENERAL MARKET	1 OF 1	