

Wideband RF LDMOS Integrated Power Amplifier 15 W, 28 V, 1800 – 2200 MHz

Description

The PTMA210152M is a wideband, matched, 15-watt, 2-stage LDMOS integrated amplifier intended for wideband driver applications in the 1800 to 2200 MHz band. This device is offered in a 20-lead thermally-enhanced overmolded package for cool and reliable operation.

PTMA210152M
Package PG-DSO-20-63

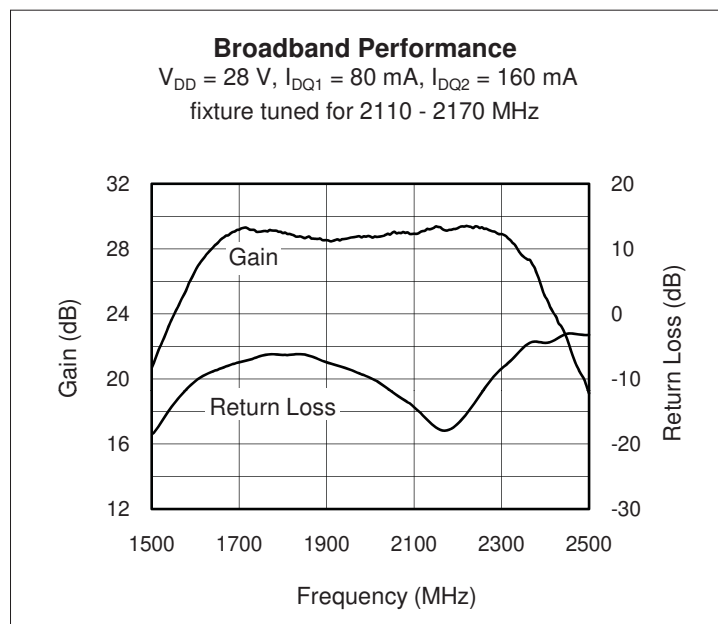

Features

- Designed for wide RF bandwidth and low memory effects
- Broadband input on-chip matching
- Typical two-carrier WCDMA performance at 2140 MHz, 28 V, 7 W avg.
 - Gain = 28.5 dB
 - Power Added Efficiency = 33 %
 - IMD3 = -32 dBc
- Typical CW performance at 2140 MHz, 28 V
 - Output power at P_{1dB} ~ 20 W
 - Efficiency > 49%
- Integrated ESD protection. Meets HBM Class 1B (minimum), per JESD22-A114F.
- Capable of handling 10:1 VSWR @ 28 V, 15 W (CW) output power
- Thermally-enhanced RoHS-compliant package

RF Characteristics

Two-carrier WCDMA Specifications (not subject to production test—verified by design/characterization in Infineon test fixture)
 $V_{DS} = 28\text{ V}$, $I_{DQ1} = 80\text{ mA}$, $I_{DQ2} = 160\text{ mA}$, $f = 2110 - 2170\text{ MHz}$, $P_{OUT} = 7\text{ W}$ average

Characteristic	Symbol	Min	Typ	Max	Unit
Gain	G_{ps}	—	28.5	—	dB
Power Added Efficiency	PAE	—	33	—	%
Input Return Loss	IRL	—	-14	—	dB
Adjacent Channel Power Ratio	ACPR	—	-36	—	dBc
Third Order Intermodulation Distortion	IMD3	—	-32	—	dBc
Spurs Load 3:1	—	—	-60	—	dBc
Gain Flatness	ΔG	—	0.43	—	dB

All published data at $T_{CASE} = 25^\circ\text{C}$ unless otherwise indicated

ESD: Electrostatic discharge sensitive device—observe handling precautions!

RF Characteristics (cont.)

Two-tone Measurement (tested in Infineon test fixture)

 $V_{DD} = 28\text{ V}$, $I_{DQ1} = 80\text{ mA}$, $I_{DQ2} = 160\text{ mA}$, $P_{OUT} = 8\text{ W AVG}$, $f = 2140\text{ MHz}$, tone spacing = 1 MHz

Characteristic	Symbol	Min	Typ	Max	Unit
Gain	G_{ps}	27.5	28.5	30	dB
Drain Efficiency	η_D	33	34	—	%
Third Order Intermodulation Distortion	IMD3	—	-33	-31	dBc
Input Return Loss	IRL	—	-14	-10	dB

DC Characteristics

Stage 1 Characteristic	Conditions	Symbol	Min	Typ	Max	Unit
Drain Leakage Current	$V_{DS} = 28\text{ V}$, $V_{GS} = 0\text{ V}$	I_{DSS}	—	—	1.0	μA
	$V_{DS} = 63\text{ V}$, $V_{GS} = 0\text{ V}$	I_{DSS}	—	—	10.0	μA
On-State Resistance	$V_{GS} = 10\text{ V}$, $V_{DS} = 0.1\text{ V}$	$R_{DS(on)}$	—	3.5	—	Ω
Operating Gate Voltage	$V_{DS} = 28\text{ V}$, $I_{DQ} = 80\text{ mA}$	V_{GS}	2	2.5	3	V
Gate Leakage Current	$V_{GS} = 10\text{ V}$, $V_{DS} = 0\text{ V}$	I_{GSS}	—	—	1.0	μA

Stage 2 Characteristic	Conditions	Symbol	Min	Typ	Max	Unit
Drain-Source Breakdown Voltage	$V_{GS} = 0\text{ V}$, $I_{DS} = 10\text{ mA}$	$V_{(BR)DSS}$	65	—	—	V
Drain Leakage Current	$V_{DS} = 28\text{ V}$, $V_{GS} = 0\text{ V}$	I_{DSS}	—	—	1.0	μA
	$V_{DS} = 63\text{ V}$, $V_{GS} = 0\text{ V}$	I_{DSS}	—	—	10.0	μA
On-State Resistance	$V_{GS} = 10\text{ V}$, $V_{DS} = 0.1\text{ V}$	$R_{DS(on)}$	—	0.6	—	Ω
Operating Gate Voltage	$V_{DS} = 28\text{ V}$, $I_{DQ} = 160\text{ mA}$	V_{GS}	2	2.5	3	V
Gate Leakage Current	$V_{GS} = 10\text{ V}$, $V_{DS} = 0\text{ V}$	I_{GSS}	—	—	1.0	μA

Maximum Ratings

Parameter	Symbol	Value	Unit	
Drain-Source Voltage	V_{DSS}	65	V	
Gate-Source Voltage	V_{GS}	-0.5 to +12	V	
Junction Temperature	T_J	200	°C	
Input Power	P_{IN}	15	dBm	
Total Device Dissipation	P_D	70	W	
Above 25°C derate by		0.4	W/°C	
Storage Temperature Range	T_{STG}	-40 to +150	°C	
Thermal Resistance ($T_{CASE} = 70^\circ\text{C}$, 15 W CW)	Stage 1	$R_{\theta JC}$	10.7	°C/W
	Stage 2	$R_{\theta JC}$	2.9	°C/W

Moisture Sensitivity Level

Level	Test Standard	Package Temperature	Unit
3	IPC/JEDEC J-STD-020	260	°C

Ordering Information

Type and Version	Order Code	Package and Description	Shipping
PTMA210152M V1	PTMA210152MV1AUMA1	PG-DSO-20-63, molded plastic	Tape & Reel, 250 pcs
PTMA210152M V1 R500	PTMA210152MV1R500AUMA1	PG-DSO-20-63, molded plastic	Tape & Reel, 500 pcs

Typical Performance, circuit tuned for 2140 MHz (data taken in a production test fixture)

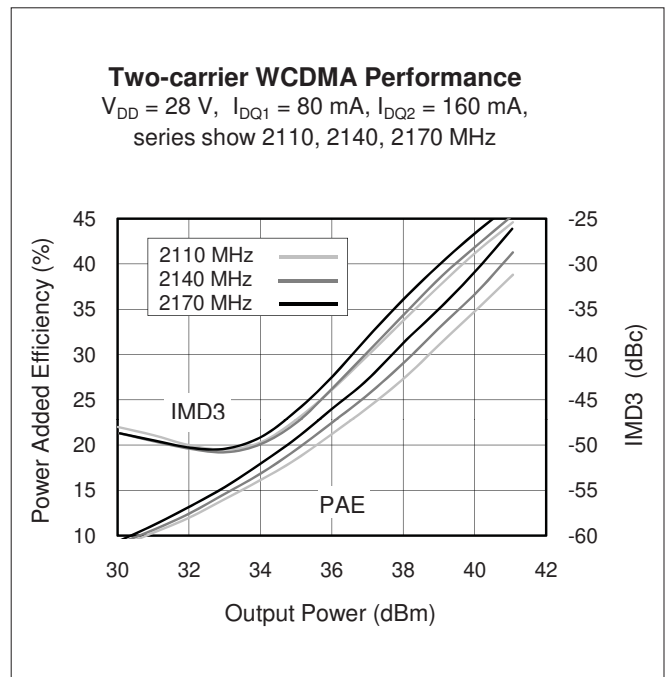
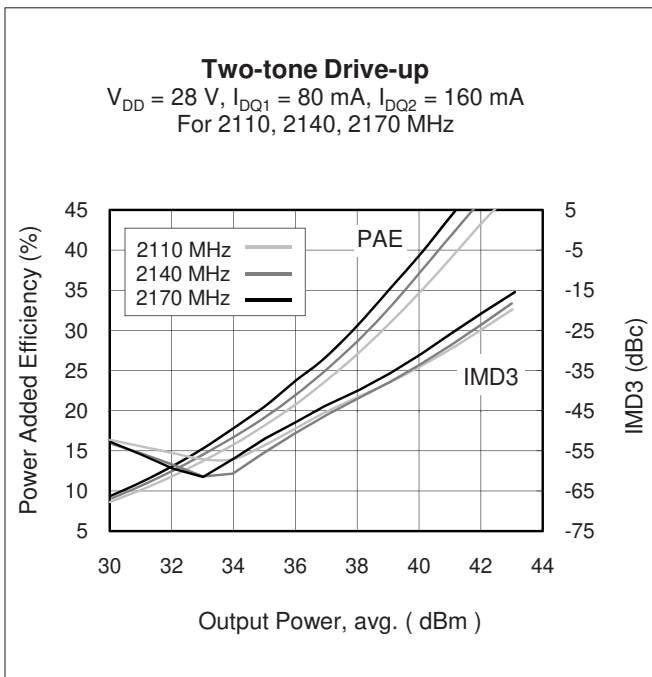
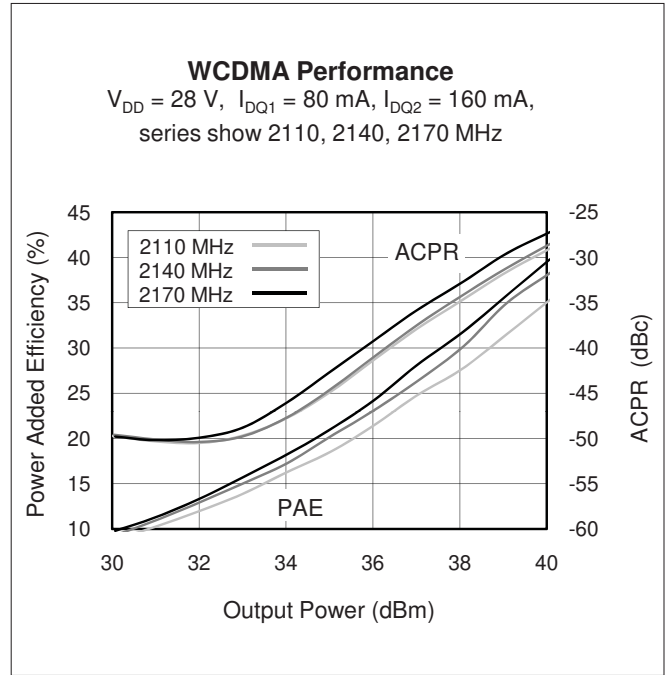
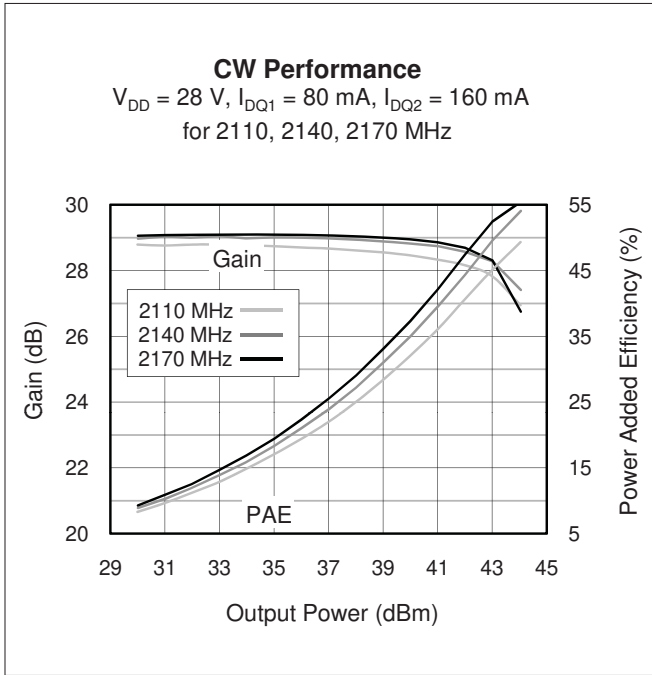

Typical Performance—2140 MHz (cont.)

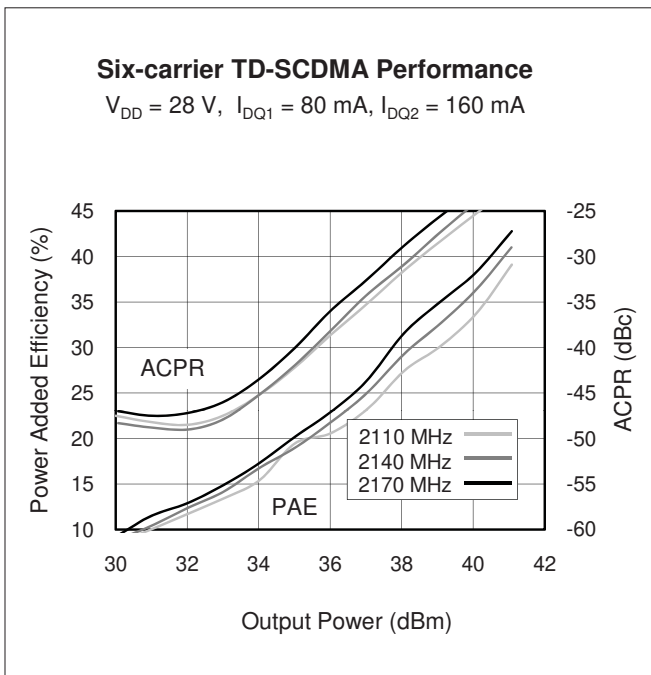
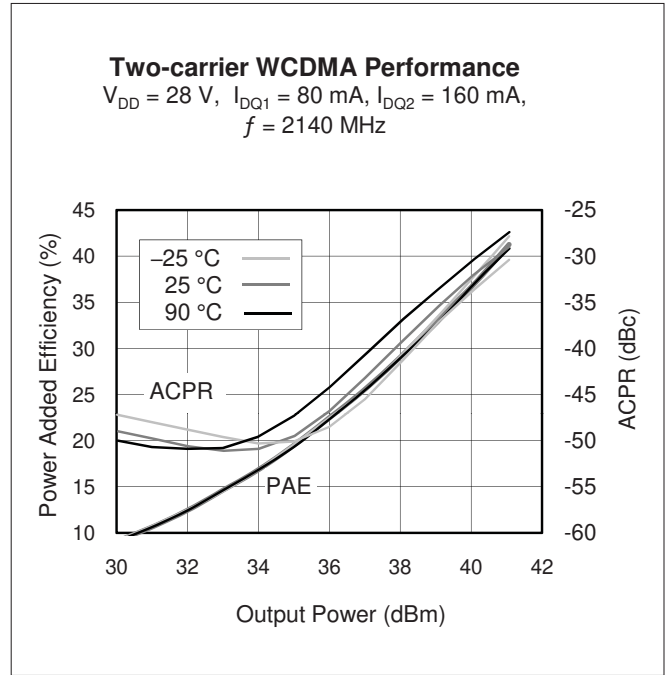
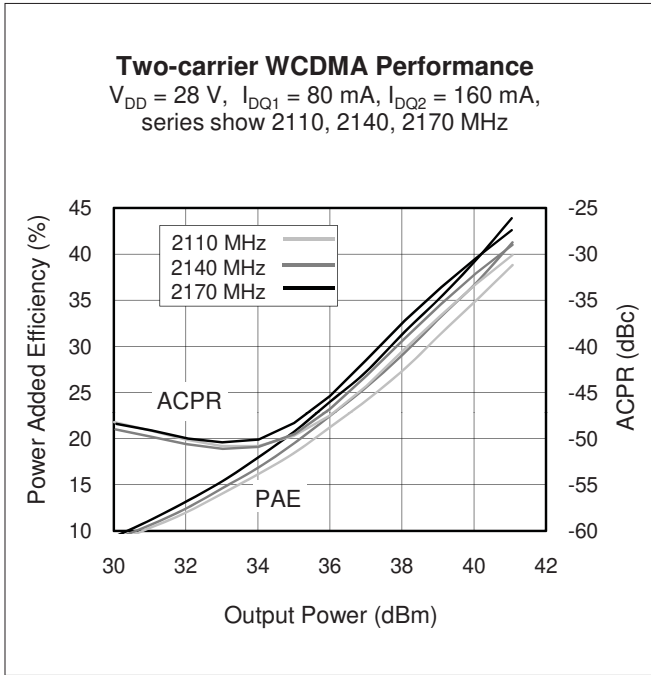

Broadband Circuit Impedance—2140 MHz

Frequency MHz	Z Load Ω	
	R	jX
2110	1.89	-5.84
2114	1.87	-5.80
2118	1.85	-5.76
2122	1.84	-5.72
2126	1.82	-5.67
2130	1.80	-5.63
2134	1.78	-5.60
2138	1.77	-5.55
2142	1.75	-5.51
2146	1.73	-5.47
2150	1.71	-5.42
2154	1.70	-5.38
2158	1.68	-5.34
2162	1.66	-5.30
2166	1.65	-5.25
2170	1.63	-5.21

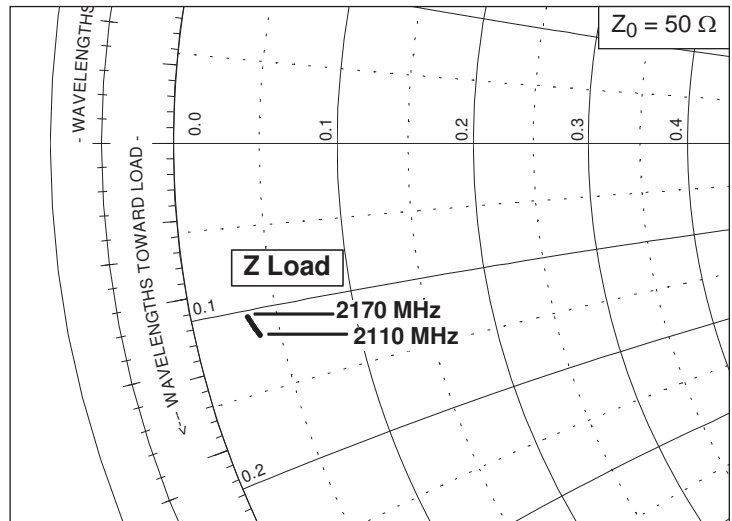
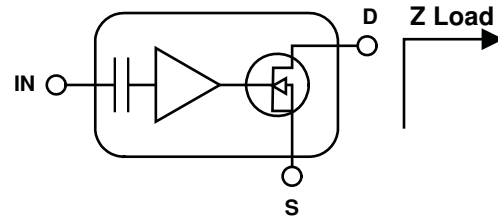

See next page for reference circuit information

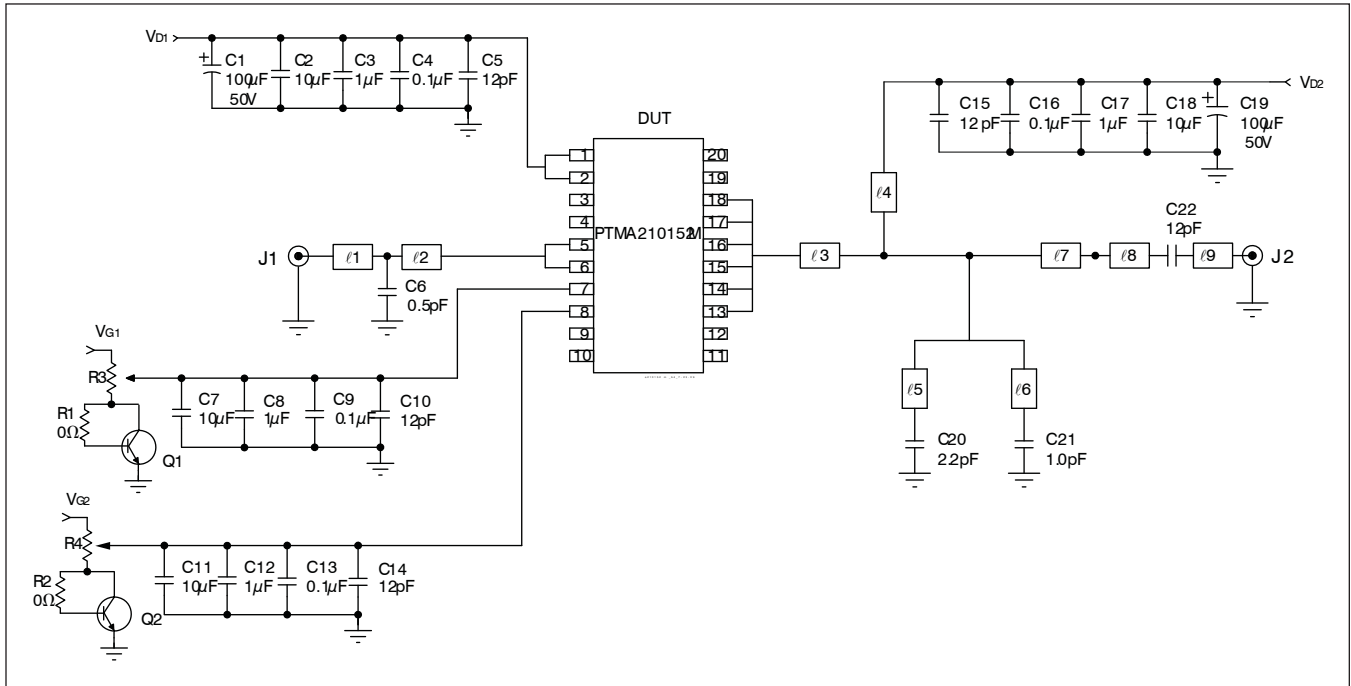
Reference Circuit—tuned for 2140 MHz

Reference circuit schematic for $f = 2140$ MHz
Circuit Assembly Information

DUT PTMA210152M, LDMOS IC

Reference Fixture Part No. LTN/PTMA210152M

PCB Rogers RO4350: 0.76 mm [.030"] thick, $\epsilon_r = 3.48$, 1 oz. copper

Find Gerber files for this reference fixture on the Infineon Web site at (<http://www.infineon.com/rfpower>)

Microstrip	Electrical Characteristics at 2140 MHz	Dimensions: L x W (mm)	Dimensions: L x W (in.)
l1	0.206λ , 50 Ω	17.48 x 1.70	0.688 x 0.067
l2	0.111λ , 50 Ω	9.40 x 1.70	0.370 x 0.067
l3	0.052λ , 11 Ω^*	4.09 x 12.83	0.161 x 0.505
l4	0.301λ , 61 Ω	25.91 x 1.19	1.020 x 0.047
l5	0.004λ , 71 Ω	0.38 x 0.89	0.015 x 0.035
l6	0.004λ , 71 Ω	0.38 x 0.89	0.015 x 0.035
l7	0.090λ , 34 Ω	7.47 x 3.00	0.294 x 0.118
l8	0.243λ , 44 Ω	20.40 x 2.11	0.803 x 0.083
l9	0.058λ , 50 Ω	4.95 x 1.70	0.195 x 0.067

**Calculated at 10.5*

Reference Circuit—2140 MHz (cont.)

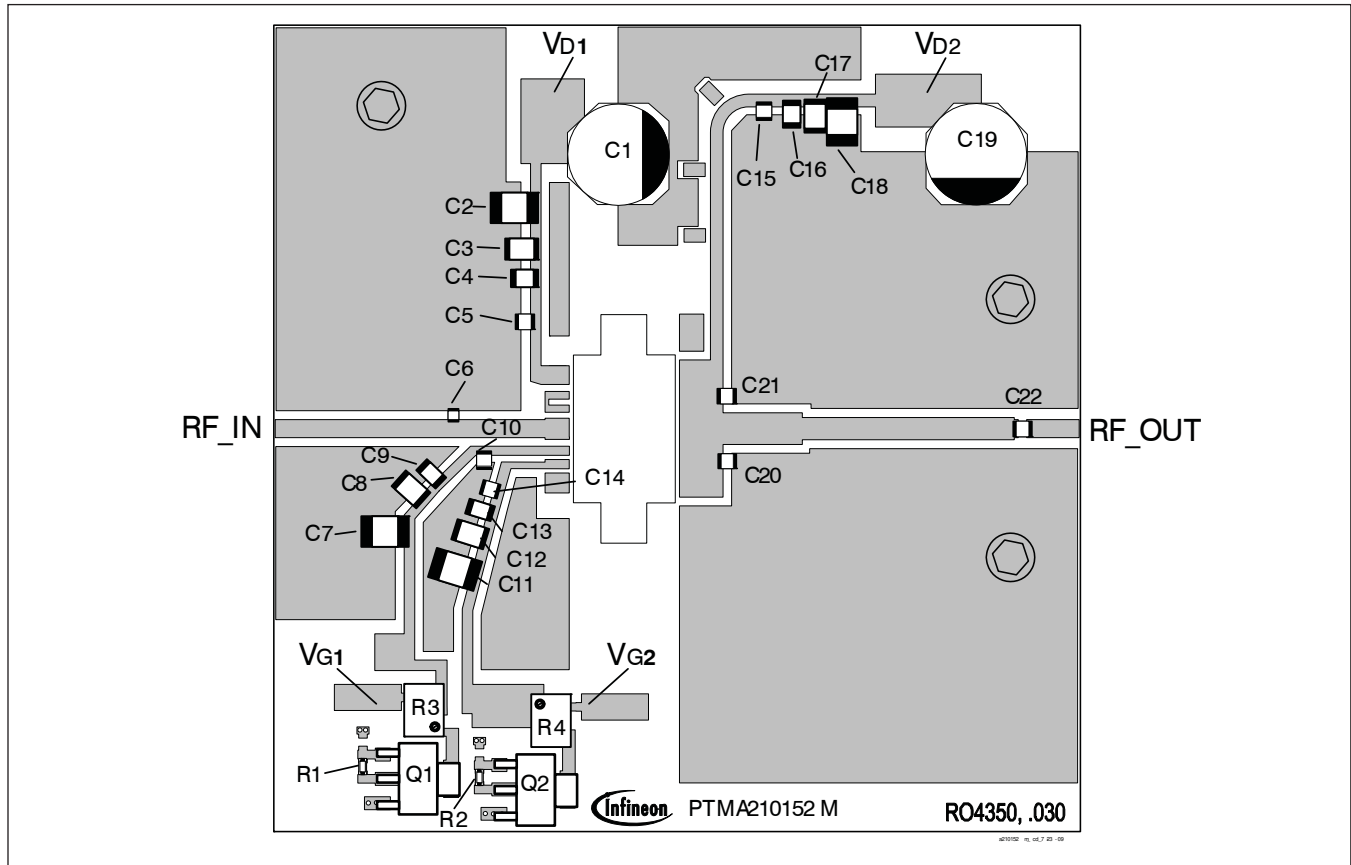

Reference circuit assembly diagram (not to scale)

Component	Description	Suggested Manufacturer	P/N or Comment
C3, C8, C12, C17	Ceramic capacitor, 1 μ F	Digi-Key	445-1411-2-ND
C4, C9, C13, C16	Capacitor, 0.1 μ F	Digi-Key	PCC104BCT-ND
C2, C7, C11, C18	Tantalum capacitor, 10 μ F, 50 V	Digi-Key	P5571-ND
C1, C19	Electrolytic capacitor, 100 μ F, 50 V	Digi-Key	PCE3718CT-ND
C6	Ceramic capacitor, 0.5 pF	ATC	600S 0R5 CT
C20	Ceramic capacitor, 2.2 pF	ATC	600S 2R2 CT
C21	Ceramic capacitor, 1.0 pF	ATC	600S 1R0 CT
C5, C10, C14, C15, C22	Ceramic capacitor, 12 pF	ATC	600S 120 JT
Q1, Q2	Transistor	Infineon Technologies	BCP56
R1, R2	Chip resistor, 0 ohms	Digi-Key	P00ECT-ND
R3, R4	Potentiometer, 2 k ohms	Digi-Key	3224W-202ETR-ND

Typical Performance, circuit tuned for 1840 MHz (data taken in a production test fixture)

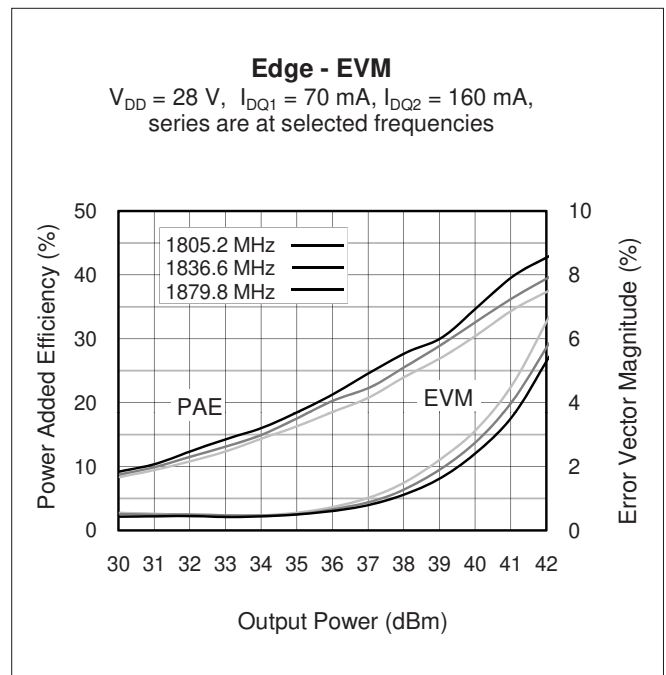
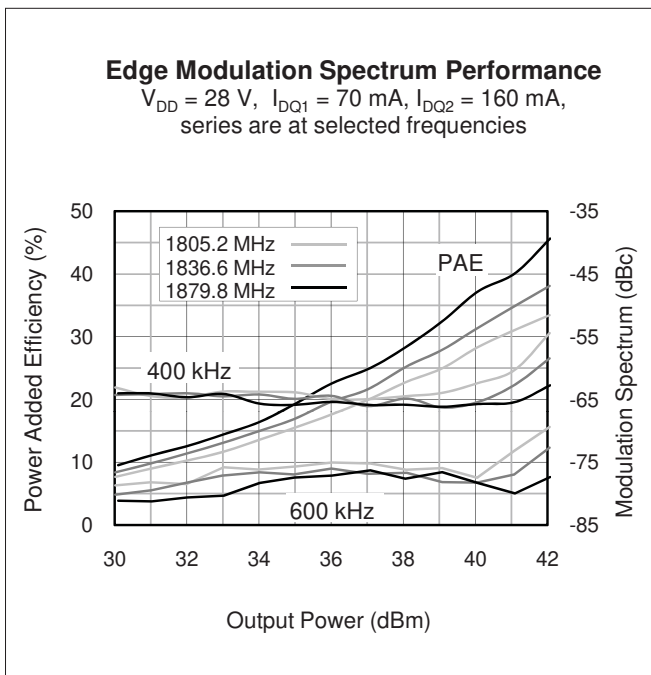
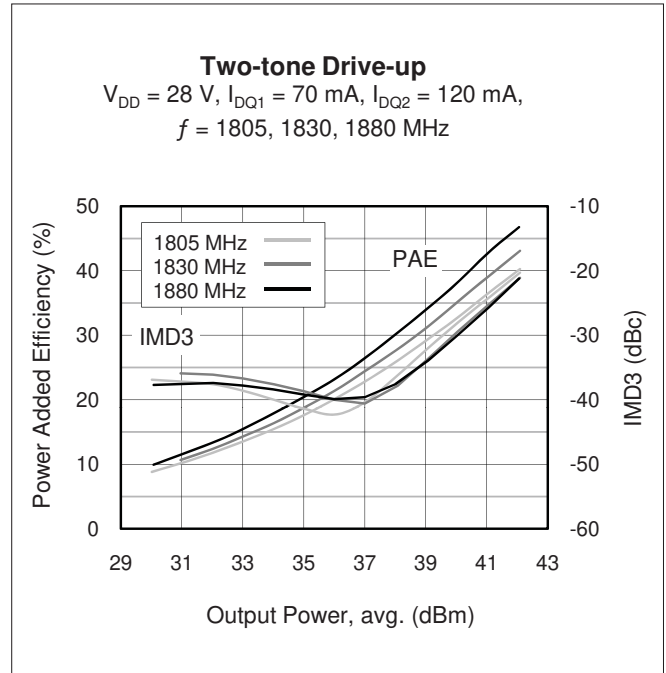
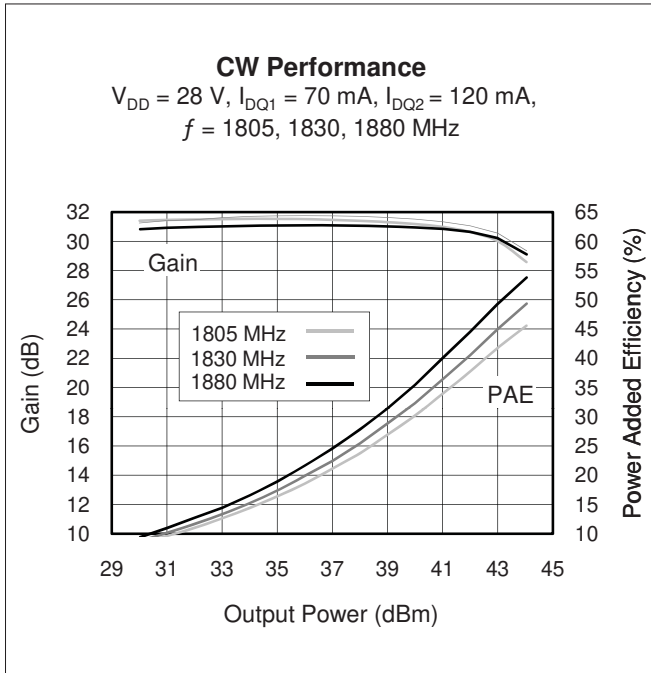

Broadband Circuit Impedance—1840 MHz

Frequency MHz	Z Load Ω	
	R	jX
1800	4.34	-7.66
1810	4.28	-7.57
1820	4.21	-7.48
1830	4.15	-7.40
1840	4.09	-7.30
1850	4.03	-7.21
1860	3.96	-7.12
1870	3.90	-7.03
1880	3.85	-6.94
1890	3.79	-6.85
1900	3.73	-6.76
1910	3.67	-6.67
1920	3.62	-6.57
1930	3.56	-6.48
1940	3.50	-6.39
1950	3.45	-6.30
1960	3.40	-6.21
1970	3.34	-6.11
1980	3.29	-6.02
1990	3.24	-5.93
2000	3.19	-5.84

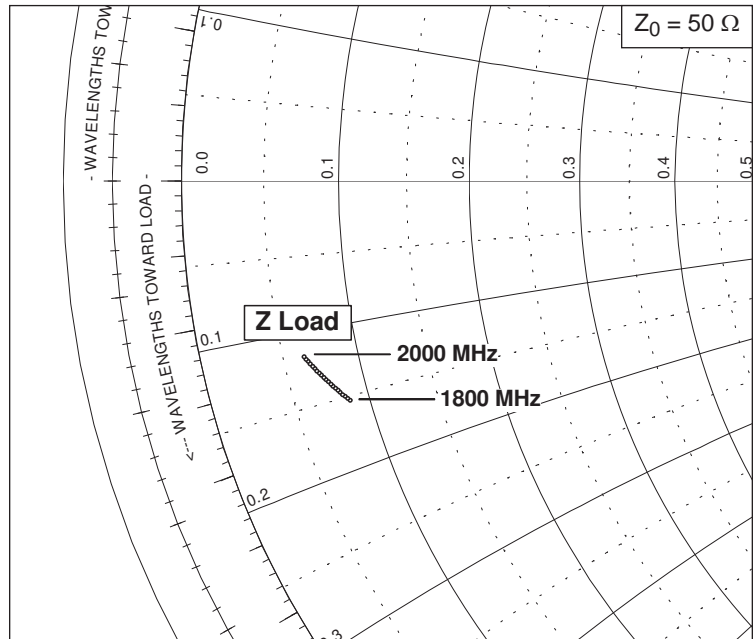
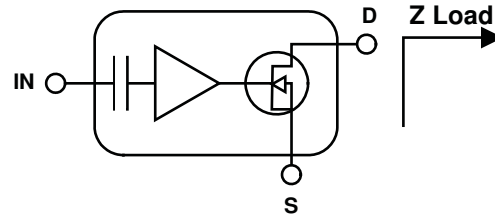

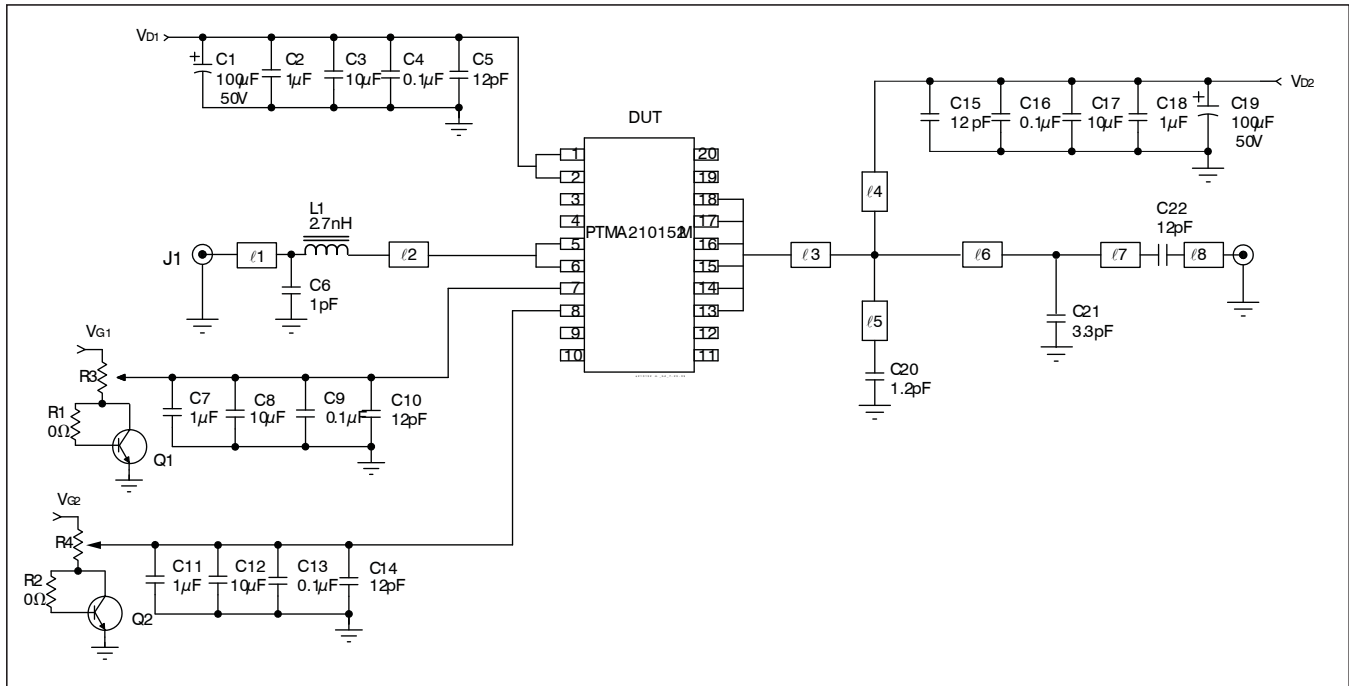
Reference Circuit, tuned for 1840 MHz

Reference circuit schematic for $f = 1840$ MHz
Circuit Assembly Information

DUT PTMA210152M, LDMOS IC

Test Fixture Part No. LTN/PTMA210152M-18

PCB Rogers RO4350: 0.76 mm [.030"] thick, $\epsilon_r = 3.48$, 1 oz. copper

Find Gerber files for this test fixture on the Infineon Web site at (<http://www.infineon.com/rfpower>)

Microstrip	Electrical Characteristics at 1840 MHz	Dimensions: L x W (mm)	Dimensions: L x W (in.)
l1	0.077λ , 50Ω	7.59 x 1.70	0.299 x 0.067
l2	0.250λ , 50Ω	24.66 x 1.70	0.971 x 0.067
l3	0.045λ , $11 \Omega^*$	4.09 x 12.83	0.161 x 0.505
l4	0.259λ , 61Ω	25.91 x 1.19	1.020 x 0.047
l5	0.004λ , 71Ω	0.38 x 0.89	0.015 x 0.035
l6	0.018λ , 44Ω	1.73 x 2.08	0.068 x 0.082
l7	0.268λ , 44Ω	26.16 x 2.08	1.030 x 0.082
l8	0.050λ , 50Ω	4.95 x 1.70	0.195 x 0.067

**Calculated at 10.5*

Reference Circuit—1840 MHz (cont.)

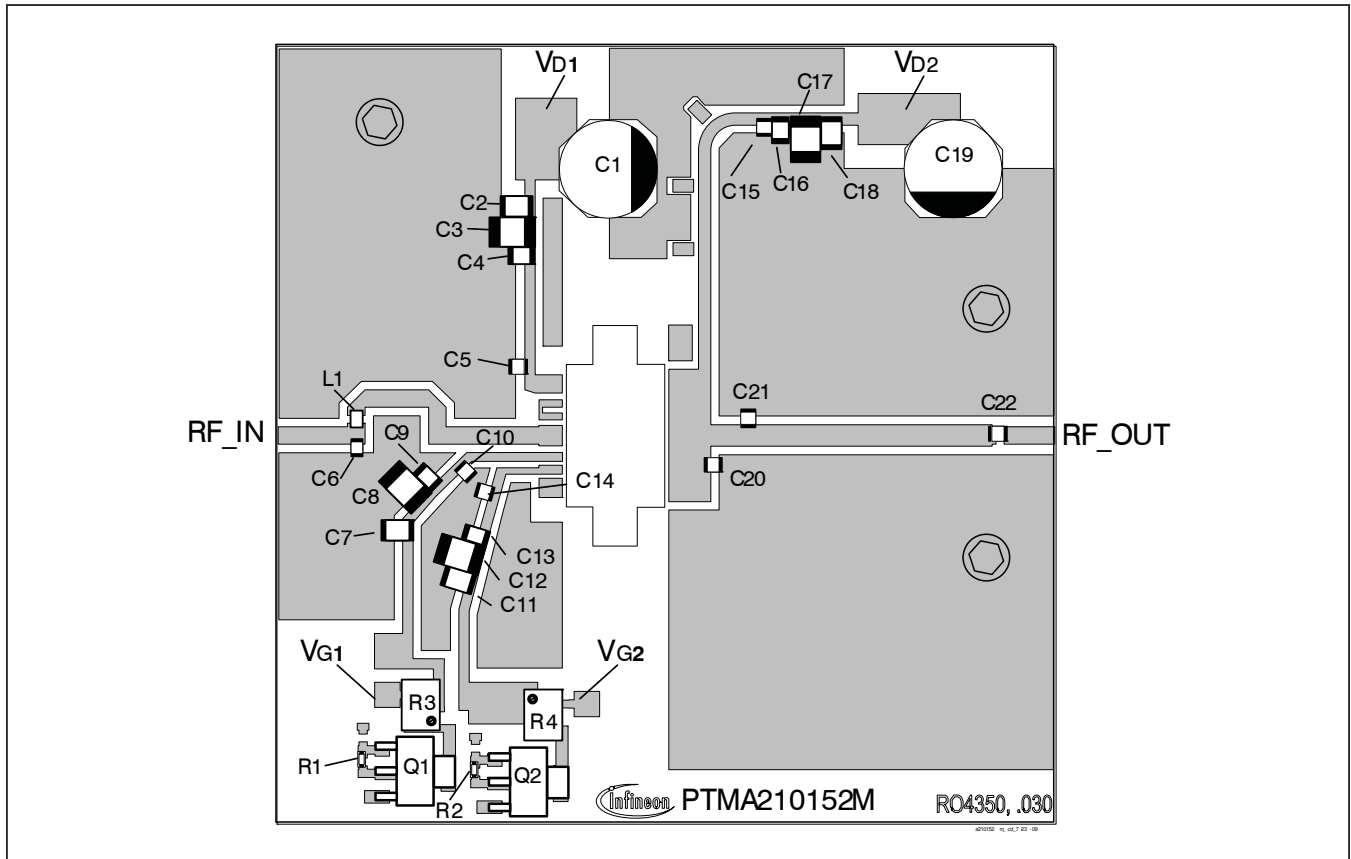

Reference circuit assembly diagram (not to scale)

Component	Description	Suggested Manufacturer	P/N or Comment
C3, C8, C12, C17	Ceramic capacitor, 1 μ F	Digi-Key	445-1411-2-ND
C4, C9, C13, C16	Capacitor, 0.1 μ F	Digi-Key	PCC104BCT-ND
C2, C7, C11, C18	Tantalum capacitor, 10 μ F, 50 V	Digi-Key	P5571-ND
C1, C19	Electrolytic capacitor, 100 μ F, 50 V	Digi-Key	PCE3718CT-ND
C6	Ceramic capacitor, 1.0 pF	ATC	600S 1R0 CT
C20	Ceramic capacitor, 1.2 pF	ATC	600S 1R2 CT
C21	Ceramic capacitor, 3.3 pF	ATC	600S 3R3 CT
C5, C10, C14, C15, C22	Ceramic capacitor, 12 pF	ATC	600S 120 JT
Q1, Q2	Transistor	Infineon Technologies	BCP56
R1, R2	Chip resistor, 0 ohms	Digi-Key	P00ECT-ND
R3, R4	Potentiometer, 2 k ohms	Digi-Key	3224W-202ETR-ND
L1	Inductor, 2.7 nH	Digi-Key	PCD1287CT-ND

Pinout Diagram (top view)

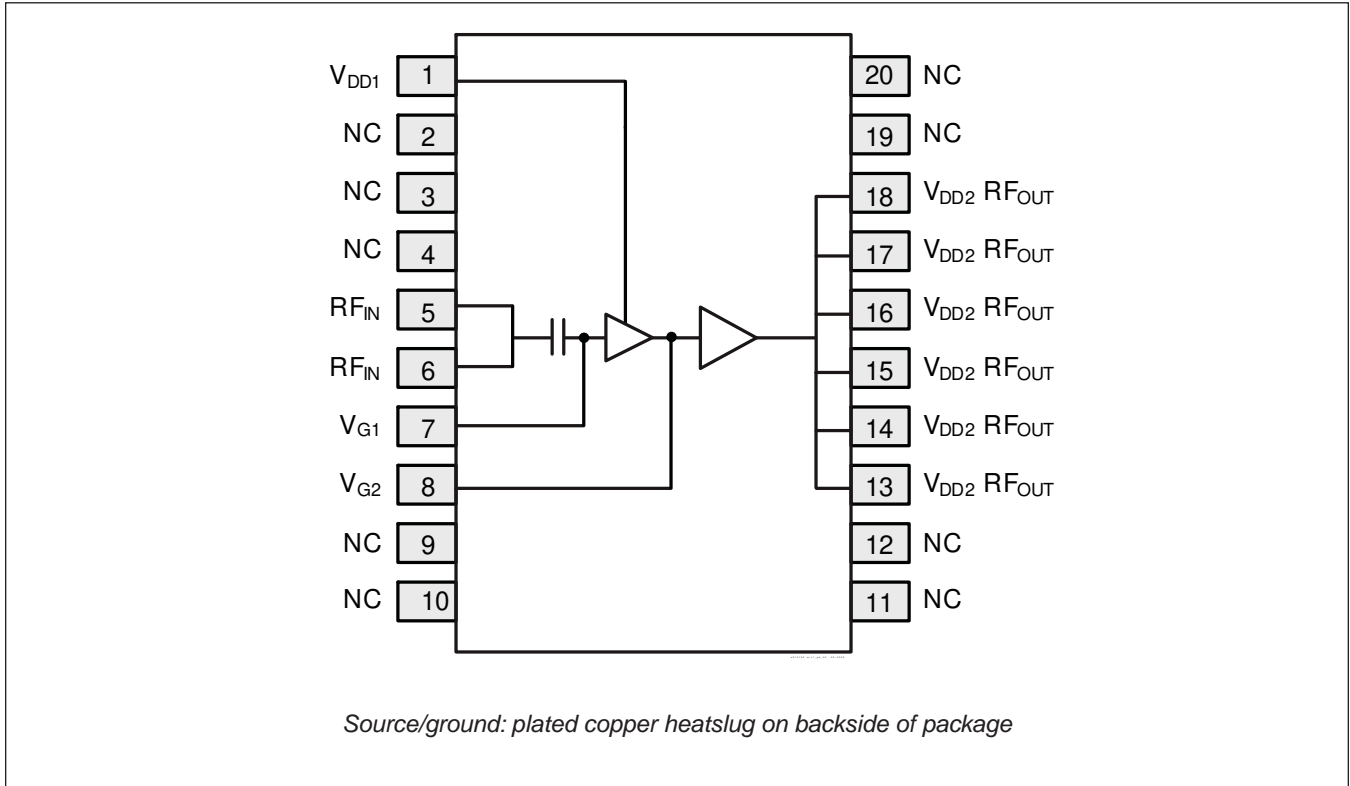

Find the latest and most complete information about products and packaging at the Infineon Internet page <http://www.infineon.com/rfpower>

Package Outline Specifications

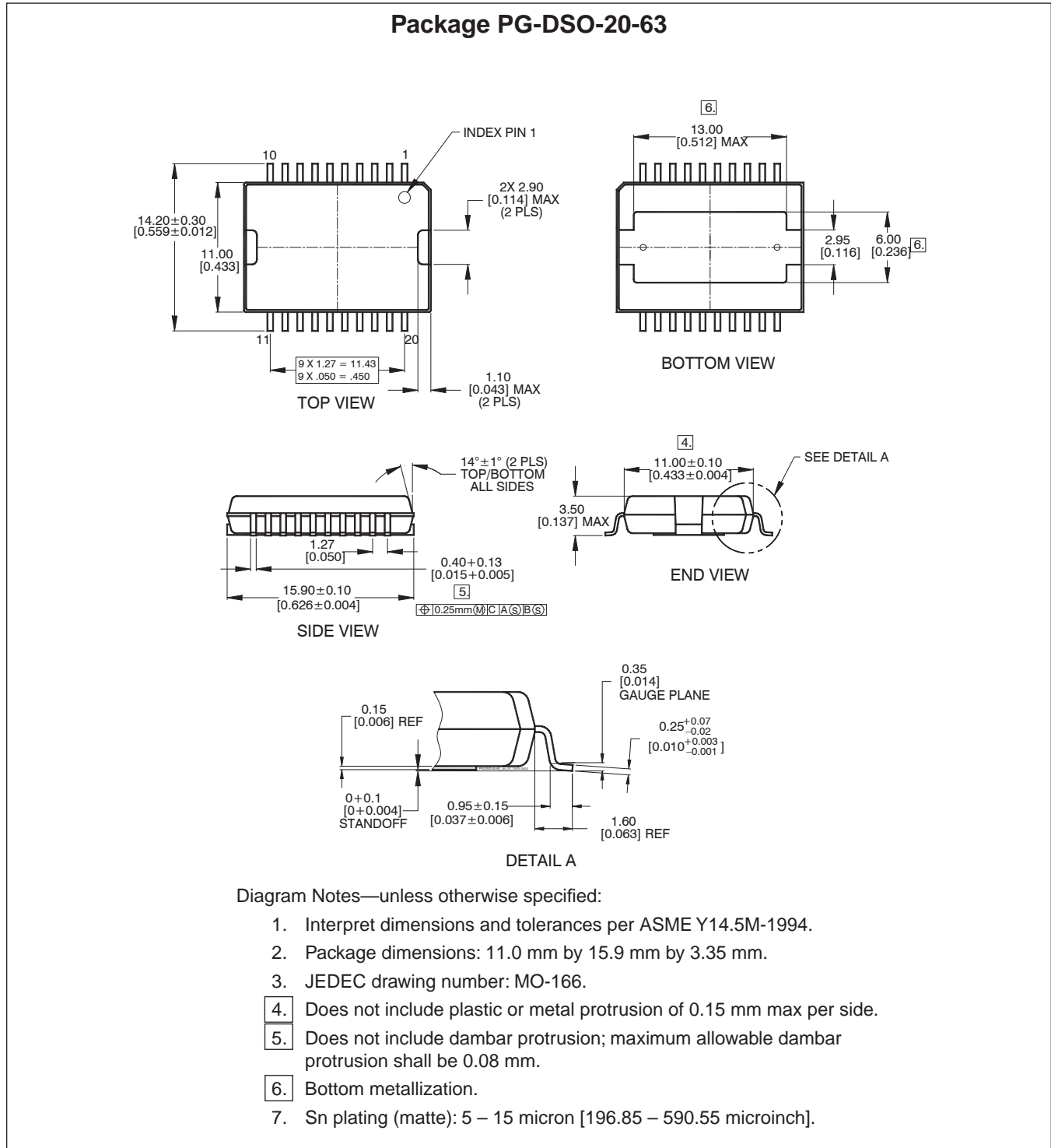

Refer to Application Note "Recommendations for Printed Circuit Board Assembly of Infineon DSO and SSOP Packages" for additional information.

Revision History

Revision	Date	Data Sheet	Page	Subjects (major changes since last revision)
01	2009-06-15	Preliminary	all	Preliminary specification for new product in development.
02	2009-08-11	Production	all	Add 1840 MHz characterization.
03	2009-09-02	Production	14	Update pinout diagram.
04	2010-04-16	Production	3; 14	Add moisture sensitivity information; update package outline notes.
05	2010-10-28	Production	6, 11	Recalculate electrical characteristics.
06	2011-04-25	Production	4, 6	Removed graphs.
07	2011-06-10	Production	2	Clarify DC characteristics per stage
08	2011-06-11	Production	2	Revise RF table to better reflect test specifications.
09	2014-05-07	Production	3	Add shipping option.

We Listen to Your Comments

Any information within this document that you feel is wrong, unclear or missing at all?
 Your feedback will help us to continuously improve the quality of this document.
 Please send your proposal (including a reference to this document) to:

highpowerRF@infineon.com

To request other information, contact us at:
 +1 877 465 3667 (1-877-GO-LDMOS) USA
 or +1 408 776 0600 International

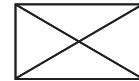

Edition 2014-05-07

Published by
Infineon Technologies AG
 85579 Neubiberg, Germany

© 2009 Infineon Technologies AG
 All Rights Reserved.

Legal Disclaimer

The information given in this document shall in no event be regarded as a guarantee of conditions or characteristics. With respect to any examples or hints given herein, any typical values stated herein and/or any information regarding the application of the device, Infineon Technologies hereby disclaims any and all warranties and liabilities of any kind, including without limitation, warranties of non-infringement of intellectual property rights of any third party.

Information

For further information on technology, delivery terms and conditions and prices, please contact the nearest Infineon Technologies Office (www.infineon.com/rfpower).

Warnings

Due to technical requirements, components may contain dangerous substances. For information on the types in question, please contact the nearest Infineon Technologies Office.

Infineon Technologies components may be used in life-support devices or systems only with the express written approval of Infineon Technologies, if a failure of such components can reasonably be expected to cause the failure of that life-support device or system or to affect the safety or effectiveness of that device or system. Life support devices or systems are intended to be implanted in the human body or to support and/or maintain and sustain and/or protect human life. If they fail, it is reasonable to assume that the health of the user or other persons may be endangered.