



The Future of Analog IC Technology®

EVQ6526-U-00A

0.9A, 28V

**Six Half-Bridge Motor Driver
Evaluation Board**

DESCRIPTION

The MPQ6526 is a six half-bridge DMOS output driver with integrated power MOSFETs. It can drive up to six different loads. The input voltage ranges from 7V to 28V, with the up to 0.9A output current capability.

The six half-bridges of MPQ6526 can be controlled separately from a standard serial data interface, and have various diagnostic functions. It has very low quiescent current in standby mode make a wide range of applications possible.

Fully protection includes short-circuit protection, under-voltage protection and thermal shutdown.

ELECTRICAL SPECIFICATIONS

Parameter	Symbol	Value	Units
Input Voltage	V_{IN}	7 – 28	V
Maximum Output Current	I_{OUT-L}	0.9	A

FEATURES

- Wide 7V to 28V Operating Input Range
- Up to 0.9A Output Current for Each Channel
- Total Max Current 2.4A (all outputs combined)
- R_{dson} (HS + LS) Typically 1.1 Ω at 25°C, Maximum 2 Ω at 150°C
- Very Low Quiescent Current $I_{VS} < 6\mu A$ in Standby Mode Versus Total Temperature Range
- Serial Data Interface
- Short-Circuit Protection
- Under-Voltage Protection

APPLICATIONS

- Drive various loads in automotive and industrial applications
- DC Motors

All MPS parts are lead-free, halogen free, and adhere to the RoHS directive. For MPS green status, please visit MPS website under Quality Assurance. "MPS" and "The Future of Analog IC Technology" are Registered Trademarks of Monolithic Power Systems, Inc.

EVQ6526-U-00A EVALUATION BOARD

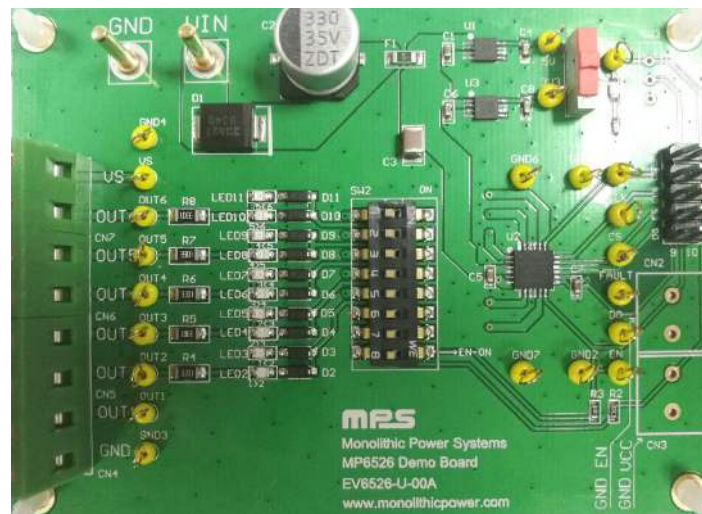

(L x W x H) 3.73" x 2.74" x 0.4"
(9.33cm x 6.85cm x 1cm)

Board Number	MPS IC Number
EVQ6526-U-00A	MPQ6526

EVALUATION BOARD SCHEMATIC

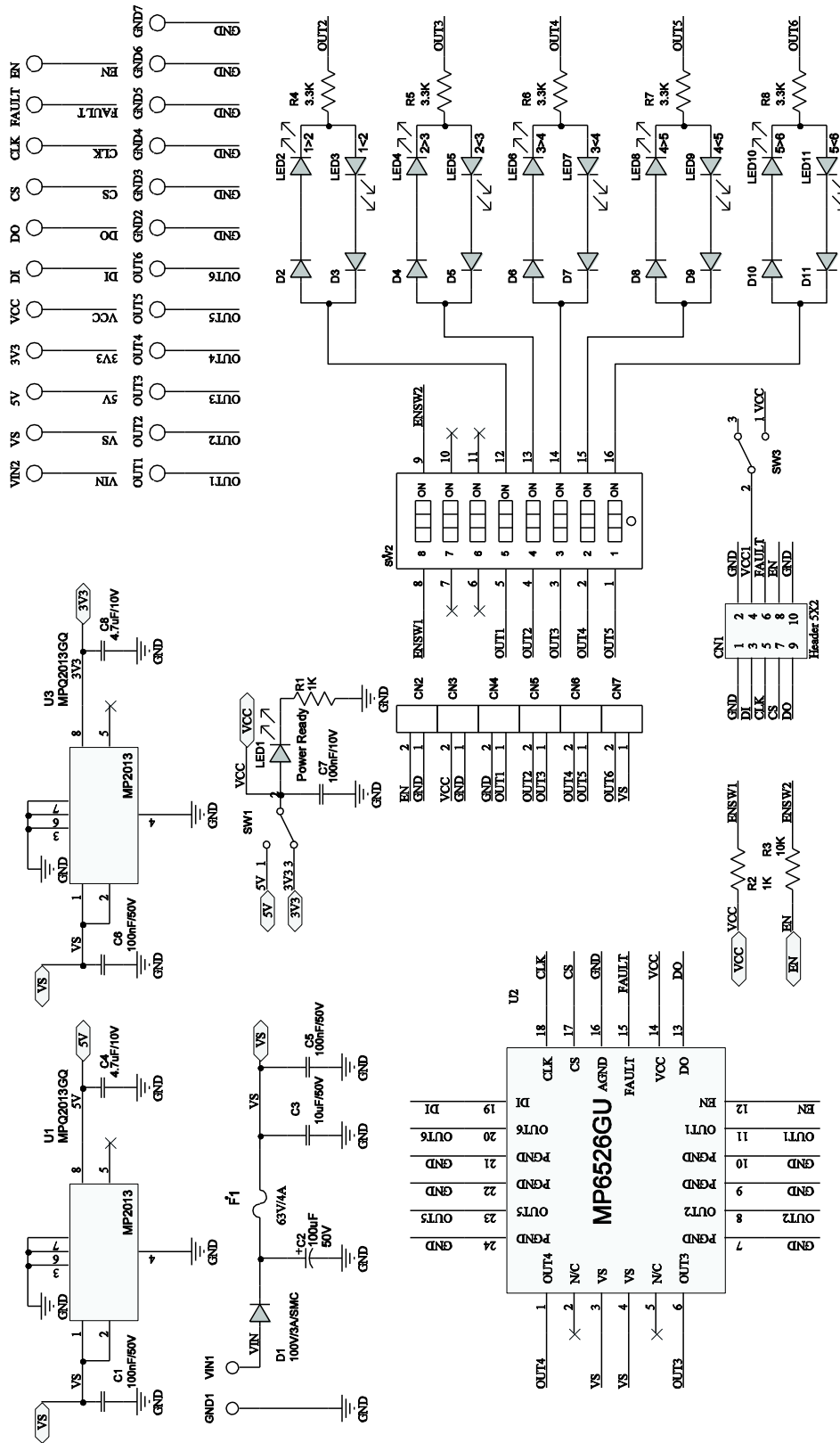

EVQ6526-U-00A BILL OF MATERIALS

Qty	Ref	Value	Description	Package	Manufacturer	Part Number
22	5V, 3.3V, CLK, CS, DI, DO, EN, FAULT, GND2, GND3, GND4, GND5, GND6, GND7, OUT1, OUT2, OUT3, OUT4, OUT5, OUT6, VCC, VS1		Test Point			
2	C4, C8	1 μ F/10V	Ceramic Capacitor; 10V;X7R	0603	Murata	GRM188R71A105KA61D
4	C1, C5, C6, C7	100nF/50V	Ceramic Capacitor; 50V;X7R	0603	Murata	GCJ188R71H104KA12D
1	C2	330 μ F	Electrolytic Capacitor;35V ;Electrolytic;S MD	SMD	Jianghai	VZ1-35V330
1	C3	10 μ F/50V	Capacitor;50V	1210	TDK	C3225X7R1H106K
1	CN1		Header, 5x2- Pin, Dual row			
2	CN2, CN3	NS				
4	CN4, CN5, CN6, CN7		CONN/2PIN/2 MM			
1	D1	B340	Diode;40V;3A;	SMC	Diodes	B340
10	D2, D3, D4, D5, D6, D7, D8, D9, D10, D11	1N4148W	Diode;75V; 0.15A;	SOD-123	Diodes	1N4148W
1	F1	CC12H4A	Fuse;63V;4A;	1206	COOPER	CC12H4A
2	GND, VIN		Connector, 2mm			
11	LED1, LED2, LED3, LED4, LED5, LED6, LED7, LED8, LED9, LED10, LED11	BL- HUF35A- TRB	LED;Red;	0805	BRIGHT LED	BL-HUF35A-TRB
1	R1	1k	Film Res., 1%	0603	Yageo	RC0603FR-071KL
2	R2, R3	10k	Film Res., 1%	0603	Yageo	RC0603FR-0710KL
5	R4, R5, R6, R7, R8	3.3k	Film Resistor;1%	1206	Yageo	RC0603FR-071KL
1	SW1		Switch		Würth	450301014042
1	SW2		8 Bit Dial Switch	SMD	Würth	418121270808

EVQ6526-U-00A BILL OF MATERIALS *(continued)*

Qty	Ref	Value	Description	Package	Manufacturer	Part Number
1	SW3	NS				
1	U1	MPQ2013 AGQ-5-Z	5V step down regulator		MPS	MPQ2013AGQ-5-Z R10
1	U3	MPQ2013 AGQ-33-Z	3.3V step down regulator		MPS	MPQ2013AGQ-33-Z R7
1	U2	MPQ6526	Six half-bridge motor driver with serial input control	QFN5x5	MPS	MPQ6526GU-R3

PRINTED CIRCUIT BOARD LAYOUT

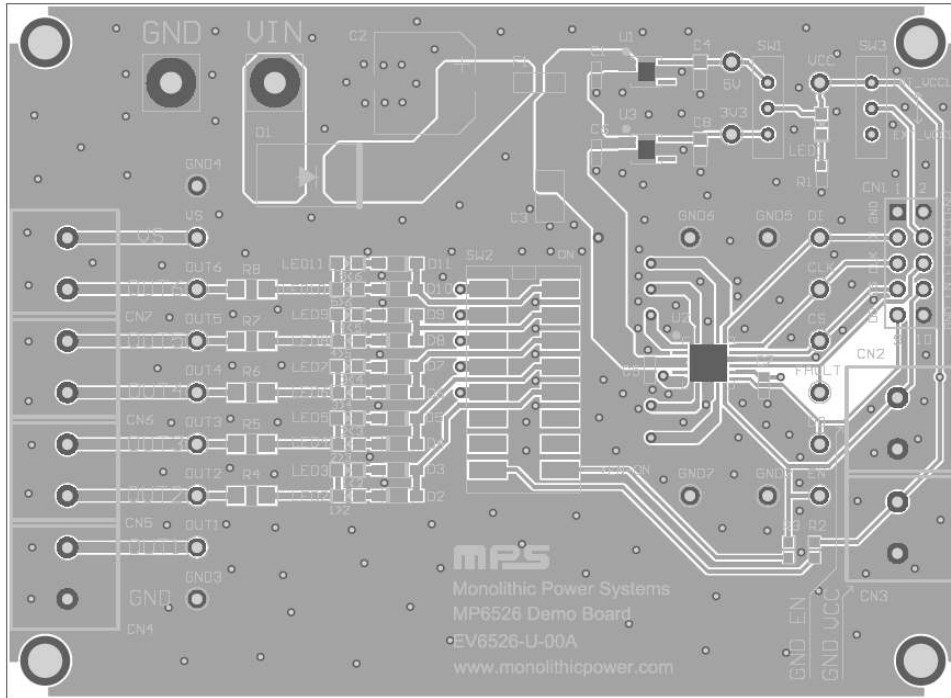

Figure 1—Top Layer

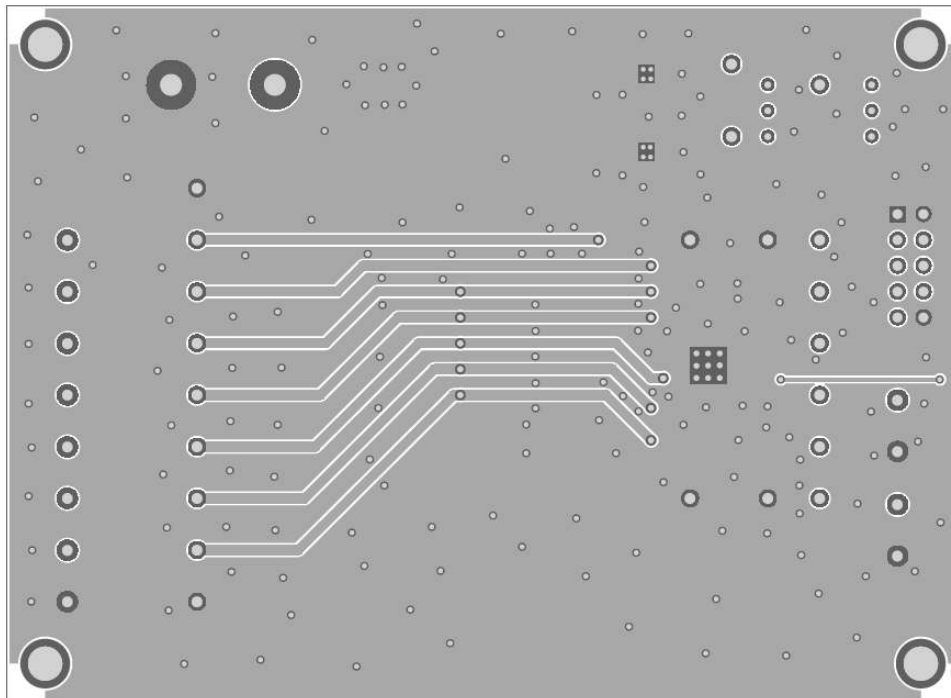

Figure 2—Bottom Layer

QUICK START GUIDE

1. Power Requirements

- a. Power supply range: 7V to 28V, 3A Max.

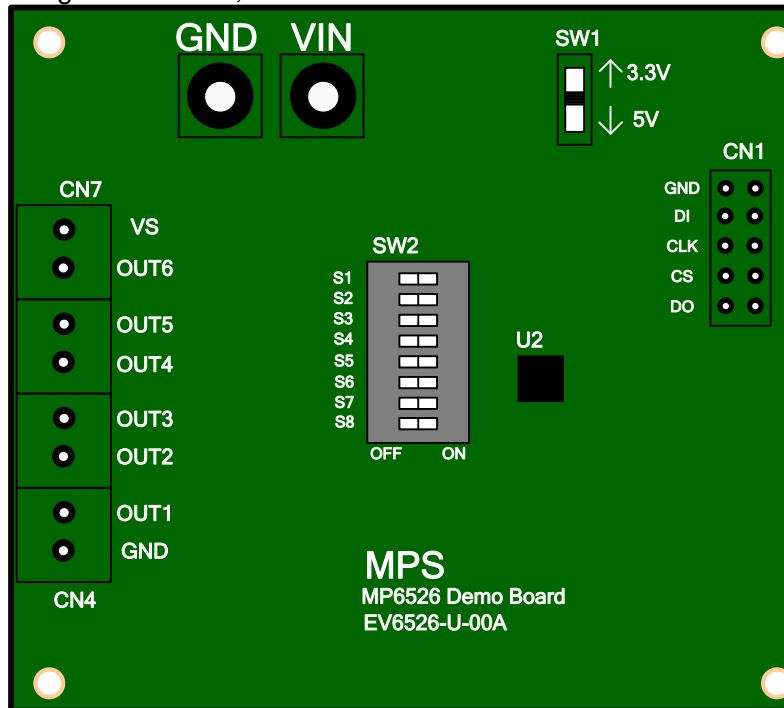

Figure 3 — EVQ6526-U-00A Bird's-eye View

2. Setup Condition

- a. Adjust the power supply VIN with recommended operating range (7V to 28V).
- b. Input for VCC power supply is on board (5V or 3.3V, use SW1 to adjust).
- c. Easy adaptation of loads by CN4 - CN7.
- d. EN alternatively connected to VCC or GND, selected by S8 of SW2.
- e. Serial data interface control via CN1 connectors.

3. Monitors

- a. For full-bridge application, indicate rotation direction of DC motors can be observed by LEDs if S1 – S5 of SW2 switches ON position.
- b. All pins are easily accessible via test points.
- c. A low output at FAULT indicates that the IC has detected an over-temperature or over-current condition.

NOTICE: The information in this document is subject to change without notice. Users should warrant and guarantee that third party Intellectual Property rights are not infringed upon when integrating MPS products into any application. MPS will not assume any legal responsibility for any said applications.