

Evaluating the **ADF4371** Microwave Wideband Synthesizer with Integrated VCO

FEATURES

Selfcontained board, including **ADF4371** frequency synthesizer with integrated VCO, loop filter (180 kHz), USB interface, and voltage regulators

Windows®-based software allows control of synthesizer functions from a PC

Externally powered by 6 V

EVALUATIONKIT CONTENTS

EV-ADF4371SD2Z evaluation board

EQUIPMENT NEEDED

Windows-based PC with USB port for evaluation software

System demonstration platform, serial only (**SDP-S**)

EVAL-SDP-CS1Z controller board

Power supply (6 V)

Spectrum analyzer

50 Ω terminators

Low noise REF_{IN} source (optional)

DOCUMENTS NEEDED

ADF4371 data sheet

EV-ADF4371SD2Z user guide

REQUIRED SOFTWARE

ACE software, Version 1.10 or newer

ADF4371 plugin, Version 0.1.6 or newer

GENERAL DESCRIPTION

The EV-ADF4371SD2Z evaluates the performance of the **ADF4371** frequency synthesizer with an integrated voltage controlled oscillator (VCO) for phase-locked loops (PLLs). A photograph of the evaluation board is shown in Figure 1. The evaluation board contains the **ADF4371** frequency synthesizer with an integrated VCO, a USB interface, power supply connectors, and subminiature Version A (SMA) connectors.

This board requires an **SDP-S** board (not supplied with the kit). The **SDP-S** allows software programming of the EV-ADF4371SD2Z device.

Full specifications for the **ADF4371** frequency synthesizer are available in the product data sheet, which must be consulted in conjunction with this user guide when working with the evaluation board.

EV-AD4371SD2Z EVALUATION BOARD PHOTOGRAPH

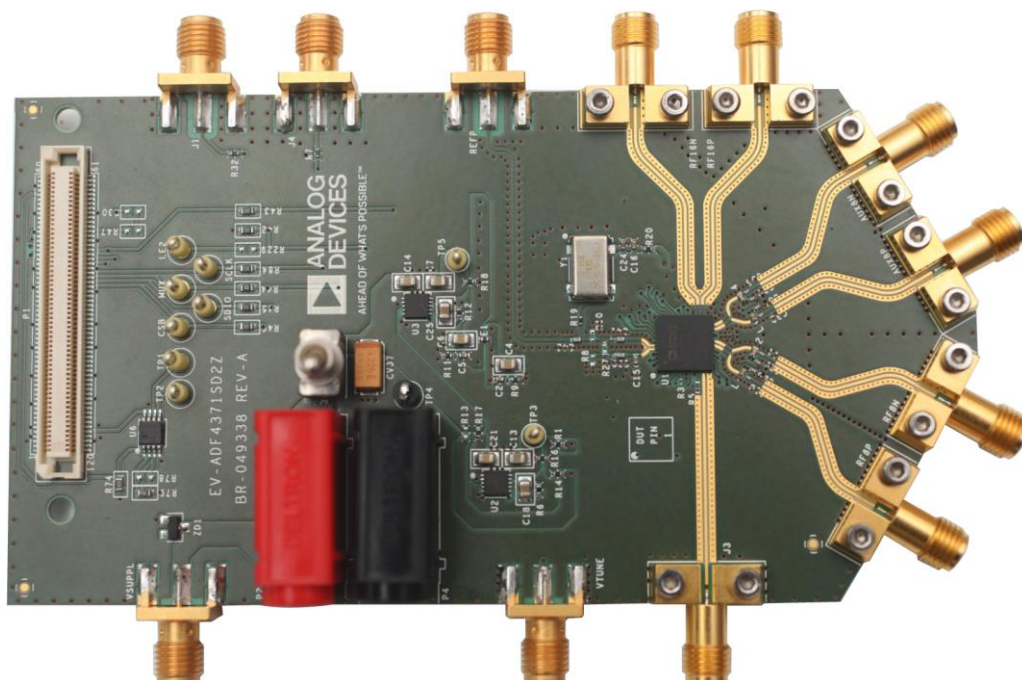

Figure 1.

17296-001

TABLE OF CONTENTS

Features	1	RF Output.....	4
Evaluation Kit Contents.....	1	Loop Filter.....	4
Equipment Needed.....	1	Additional Optimization on Loop Filter.....	4
Documents Needed.....	1	Reference Source	4
Required Software	1	Default Configuration	4
General Description	1	Doubler and Quadrupler Output.....	4
Revision History	2	Evaluation Board Software.....	6
Evaluation Board Photograph.....	1	Main Controls.....	7
Getting Started	3	Quadrupler Output Controls.....	7
Software Installation Procedures.....	3	Evaluation and Test	9
Evaluation Board Setup Procedures.....	3	Evaluation Board Schematics and Artwork.....	10
Evaluation Board Hardware.....	4	Ordering Information.....	20
Power Supplies	4	Bill of Materials.....	20

REVISION HISTORY

1/2019—Revision 0: Initial Version

GETTING STARTED

SOFTWARE INSTALLATION PROCEDURES

To install the [ACE](#) software and [ADF4371](#) plugin, perform the following steps:

1. Install the latest version of the [ACE](#) software platform.
2. If the [ADF4371](#) plugin appears automatically, proceed to Step 4.
3. Double click the [ADF4371](#) plugin file, **Board.ADF371.0.1.6.acezip**.
4. Check that the [ADF4371](#) plugin appears when the EV-ADF4371SD2Z board is attached through the system demonstration platform (SDP) connector to the PC.

EVALUATION BOARD SETUP PROCEDURES

To run the software, perform the following steps:

1. Select **Start > All Programs > Analog Devices > ACE**.
2. On the **Select Device and Connection** tab, choose **ADF4371** and the **ADF4371 board** appears under attached hardware.
3. When connecting the EV-ADF4371SD2Z board, allow 5 sec to 10 sec for the label on the status bar to change.

EVALUATION BOARD HARDWARE

The EV-ADF4371SD2Z requires the [SDP-S](#) platform that uses the [EVAL-SDP-CS1Z](#). The [SDP-B](#) is not recommended.

The EV-ADF4371SD2Z schematics are shown in Figure 10, Figure 11, Figure 12, and Figure 13. The silkscreens for the evaluation board are shown in Figure 14 and Figure 15.

POWER SUPPLIES

The EV-ADF4371SD2Z board is powered by a 6 V power supply connected to the VSUPPL SMA, or the red banana plug, P2. Connect GND to the black banana plug, P4.

The power supply circuitry has two [LT3045](#), high performance, low noise, and low dropout (LDO) regulators.

One [LT3045](#) is used to generate 5 V to drive the VCO supply pins. The remaining supplies are powered from the other [LT3045](#), which is set to 3.3 V voltage.

Use Switch S1 to switch the 6 V to the board on and off.

RF OUTPUT

The EV-ADF4371SD2Z has three pairs of SMA, 3.5 mm output connectors: RF8P/RF8N, AUX8P/AUX8N, and RF16P/RF16N (differential outputs). The EV-ADF4371SD2Z board has one single 2.92 mm connector, J3, for the RF32P pin. RF32 is also differential, but the RF32N pin is terminated by a 50 Ω on-board resistor. Because they are sensitive to impedance mismatch, connect the radio frequency (RF) outputs to equal load impedances.

If only one port of a differential pair is used, terminate the complementary port with an equal load terminator (in general, a 50 Ω terminator).

LOOP FILTER

The loop filter schematic is included in the board schematic in Figure 10. Figure 2 shows the loop filter component placement. The loop filter on the evaluation board is optimized for fractional mode performance with a phase frequency detector (PFD) frequency of 100 MHz and 1.8 mA charge pump current. The values of the loop filter components are as follows:

- Resistors: RCPOUT = 91 Ω , R2 = 400 Ω , R4 = 200 Ω , R15 = 0 Ω
- Capacitors: C20 = 220 pF, C19 = 0.018 μ F, C23 = 330 pF

The lowest rms jitter is achieved in integer mode by using a high PFD frequency. This jitter can be tested by using the same filter with a PFD frequency of 200 MHz (enabling the doubler) and 2.4 mA charge pump current. Additional optimization is still possible depending on target frequency and integration limits.

In general, narrower loop filter bandwidths have lower spurious signals. Wide loop filters in integer N mode can achieve <50 fs jitter with very clean reference frequency input (REF_{IN}) signals.

ADDITIONAL OPTIMIZATION ON LOOP FILTER

The PLL loop bandwidth can be optimized for different parameters like reference spurs or VCO noise, depending on the system requirements.

Reducing Σ - Δ Modulator (SDM) Noise

In fractional mode, SDM noise becomes apparent and starts to contribute to overall phase noise. This noise can be reduced to insignificant levels by using a series resistor between the CPOUT pin and the loop filter. Place this resistor close to the CPOUT pin. Select a reasonable resistor value that does not affect the loop bandwidth and phase margin of the designed loop filter. In most cases, a 91 Ω resistor value produces the best results. This resistor is not required in integer mode (SDM not enabled) or when a narrow-band loop filter (SDM noise attenuated) is used. This resistor is labeled as RCPOUT in schematics.

Optimizing Spurious Signals

On the evaluation board, the loop filter is placed at the secondary side of the board to create a more compact layout and so that the board is more tolerant to external signals. Using a capacitor on the same side with the [ADF4371](#) (the primary side) results in higher isolation on internally generated spurious signals. For this purpose, a small valued capacitor (10 pF) can be placed close to the VTUNE pin to achieve lower spurious signal levels.

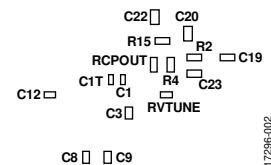

Figure 2. Loop Filter Component Placement

REFERENCE SOURCE

The EV-ADF4371SD2Z board is supplied with a low noise 100 MHz crystal oscillator (XO) from Crystek (CCHD-575-50-100.000).

To use an external single-ended REF_{IN}, connect a low noise reference source to the REFP SMA connector. Remove Resistor R19 (0 Ω) and Resistor R20 (0 Ω) to remove power from the crystal and break the connection to the REFP input.

DEFAULT CONFIGURATION

All components necessary for local oscillator (LO) generation are inserted on the EV-ADF4371SD2Z board. The EV-ADF4371SD2Z board is shipped with 100 MHz XO, the [ADF4371](#) synthesizer with an integrated VCO, and a 180 kHz loop filter (charge pump current (I_{CP}) = 1.8 mA).

DOUBLER AND QUADRUPLER OUTPUT

The [ADF4371](#) contains a frequency doubler and quadrupler to double the 4 GHz to 8 GHz VCO signal on RF16P and RF16N and quadruple the VCO signal on RF32P and RF32N. It is advised to not enable the doubler and quadrupler at the same time.

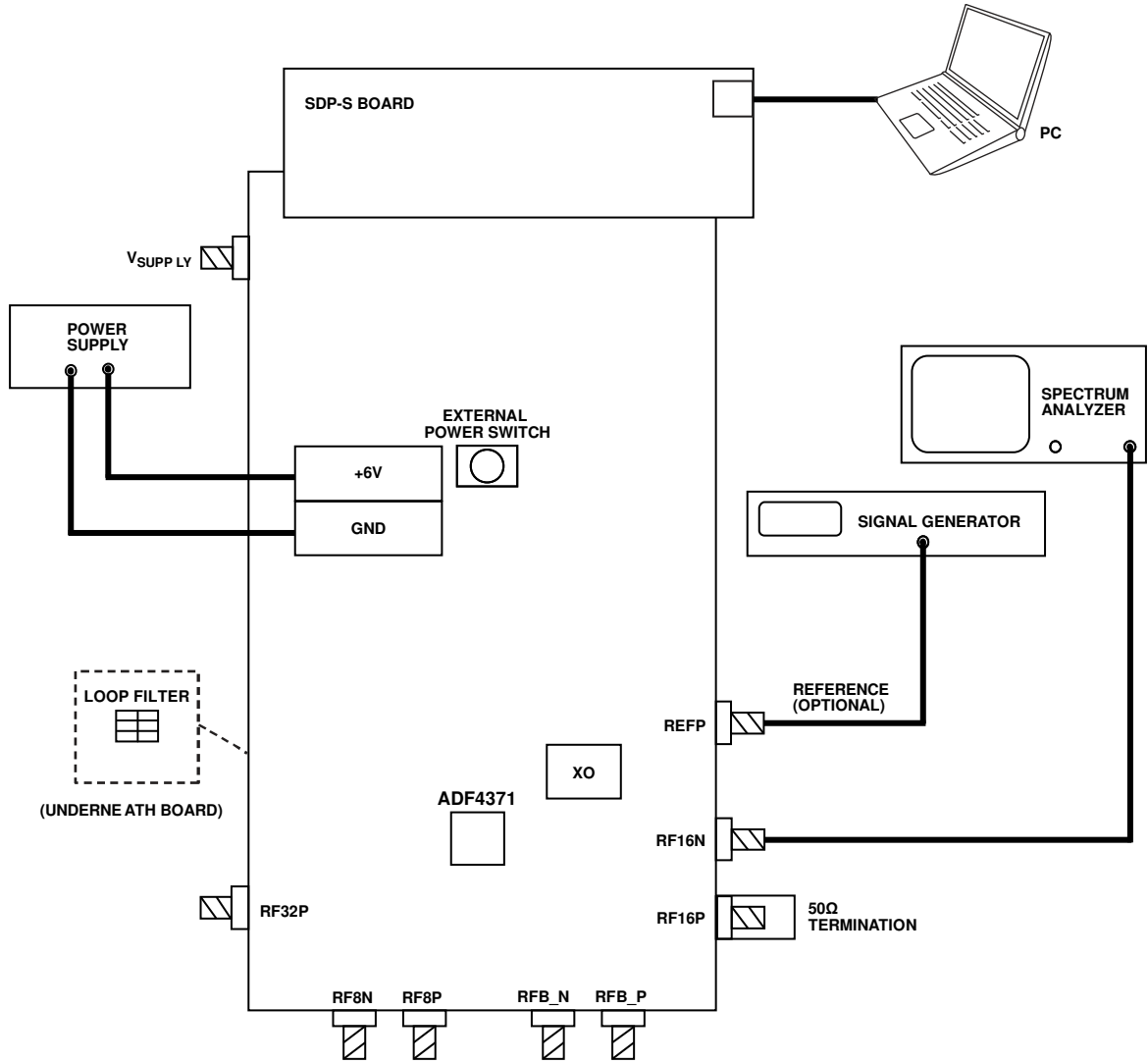

Figure 3. Evaluation Board Setup Diagram

17296-013

EVALUATION BOARD SOFTWARE

The [ACE](#) software is the main platform that is used to control the EV-ADF4371SD2Z. The [ADF4371](#) plugin includes user interfaces that relate to the [ADF4371](#) and allow evaluation of the device. Use the following steps to open the main control window for [ADF4371](#).

1. Launch the [ACE](#) application. With the [SDP-S](#) board connected to the EV-ADF4371SD2Z, the attached hardware

appears in the graphical user interface (GUI) as shown in Figure 4.

2. Double click the **ADF4371 Board** icon, and the tab shown in Figure 5 appears.
3. Double click the **ADF4371** icon that appears on the board GUI to open the main control window shown in Figure 8.

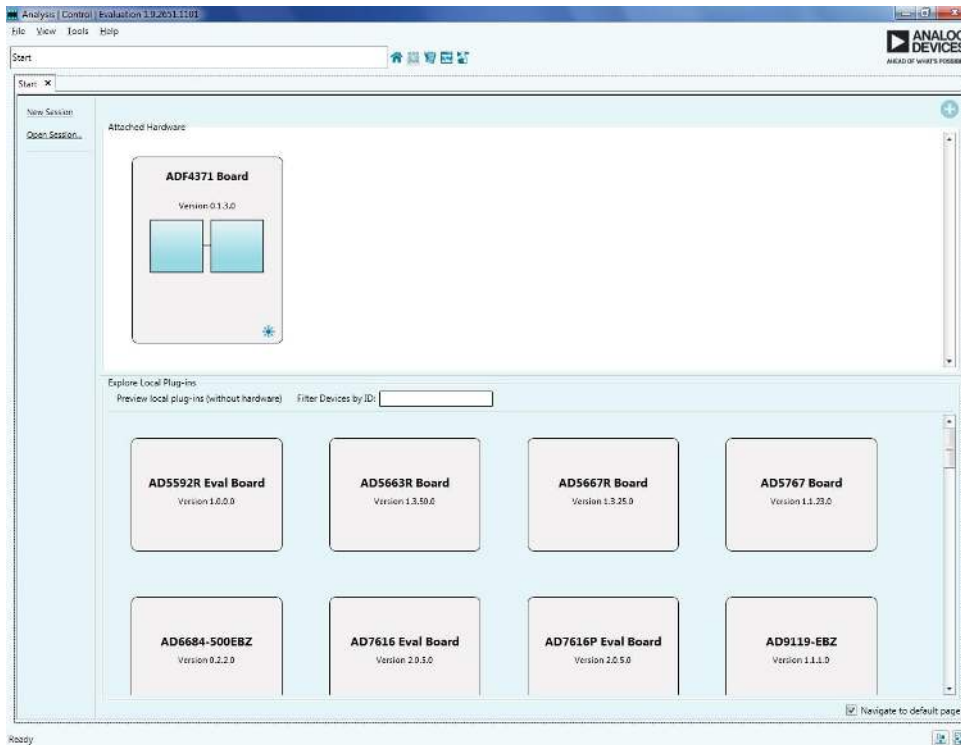

Figure 4. ACE Start Page, Attached Hardware (ADF4371 Evaluation Board)

17296-004

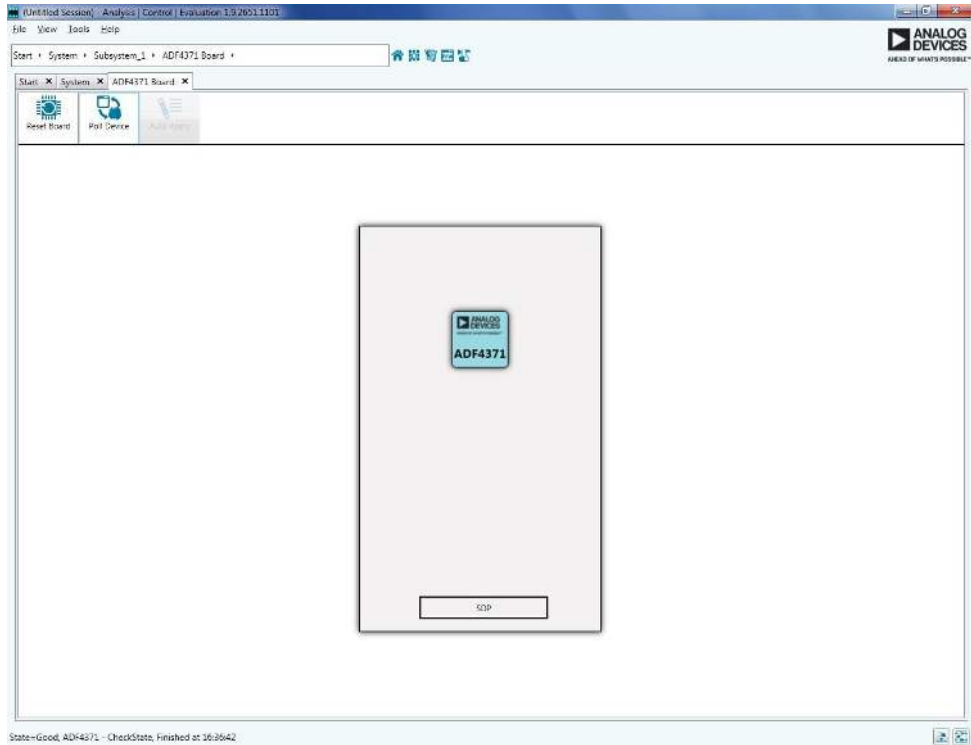

Figure 5. ACE Board Page, Device Selection

MAIN CONTROLS

The main controls are available in the high level register map shown in Figure 8. To modify registers, perform the following steps:

1. Click **Write All Registers/ Initialize** to load all registers and initialize the device.
2. Modify the registers as desired.
3. Click **Apply Changes** to load modified settings to the device. This action loads the updated registers only. All registers can be reloaded using the **Write All Registers/ Initialize** button.

QUADRUPLER OUTPUT CONTROLS

For the main, auxiliary, and doubler outputs, the optimal harmonic performance is achieved by using the automatic filter outputs. However, for the quadrupler output, some additional software settings may need to be adjusted to achieve optimal performance.

The settings are available in the **Outputs** section (shown in Figure 6). The output settings include the **Tracking Filter Mux** box that can be set to automatic or manual, the **Quad Bias** box that varies from the lowest setting 0 to the highest of 3, and the **Quad Band Filter** box that varies from 0 to 7.

The bias and filter settings in Table 1 are recommended for quadrupler output.

Table 1. Filter and Bias Setting for Quadrupled Output

Frequency (GHz)	Filter	Bias
<18	7	3
18 to 19	3	3
19 to 20.5	1	0
20.5 to 26	0	0
>26	0	1

The recommended settings for quadrupler frequencies from 16 GHz to 18 GHz are shown in Figure 6. The summarized filter performance is shown in Figure 7.



Figure 6. Recommended Quadrupler Filter Settings, 16 GHz to 18 GHz

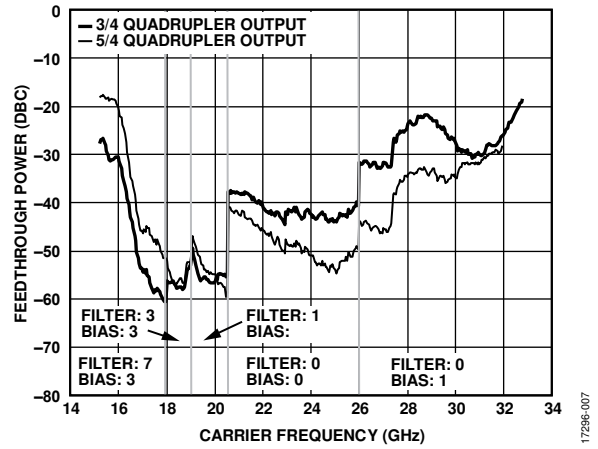

Figure 7. Aggregated Quadrupler Filter Performance, 3/4 Quadrupler Output and 5/4 Quadrupler Output

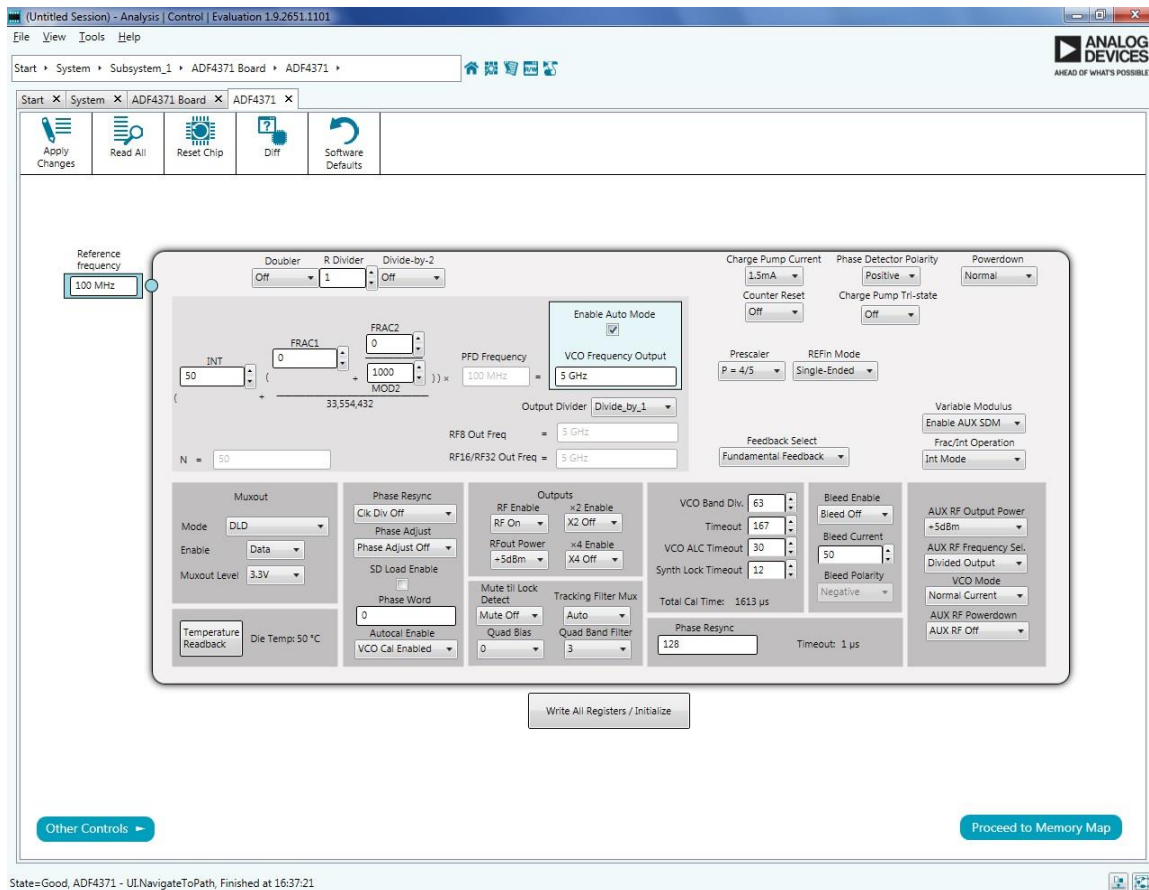

Figure 8. Software Front Panel Display, Main Controls

EVALUATION AND TEST

To evaluate and test the performance of the ADF4371, prepare the hardware and software setup as explained in the Evaluation Board Hardware section and the Evaluation Board Software section.

Run the software and set the VCO Frequency Output to 5 GHz. Measure the output spectrum and single sideband phase noise on a spectrum analyzer. Figure 9 shows a phase noise plot of the SMA RF8P pin equal to 5 GHz.

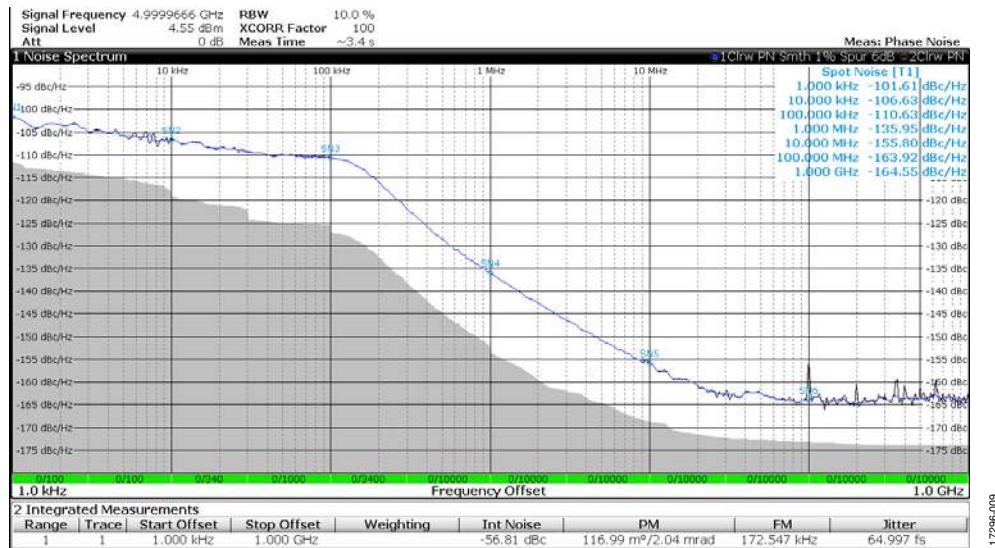

Figure 9. Single Sideband Phase Noise

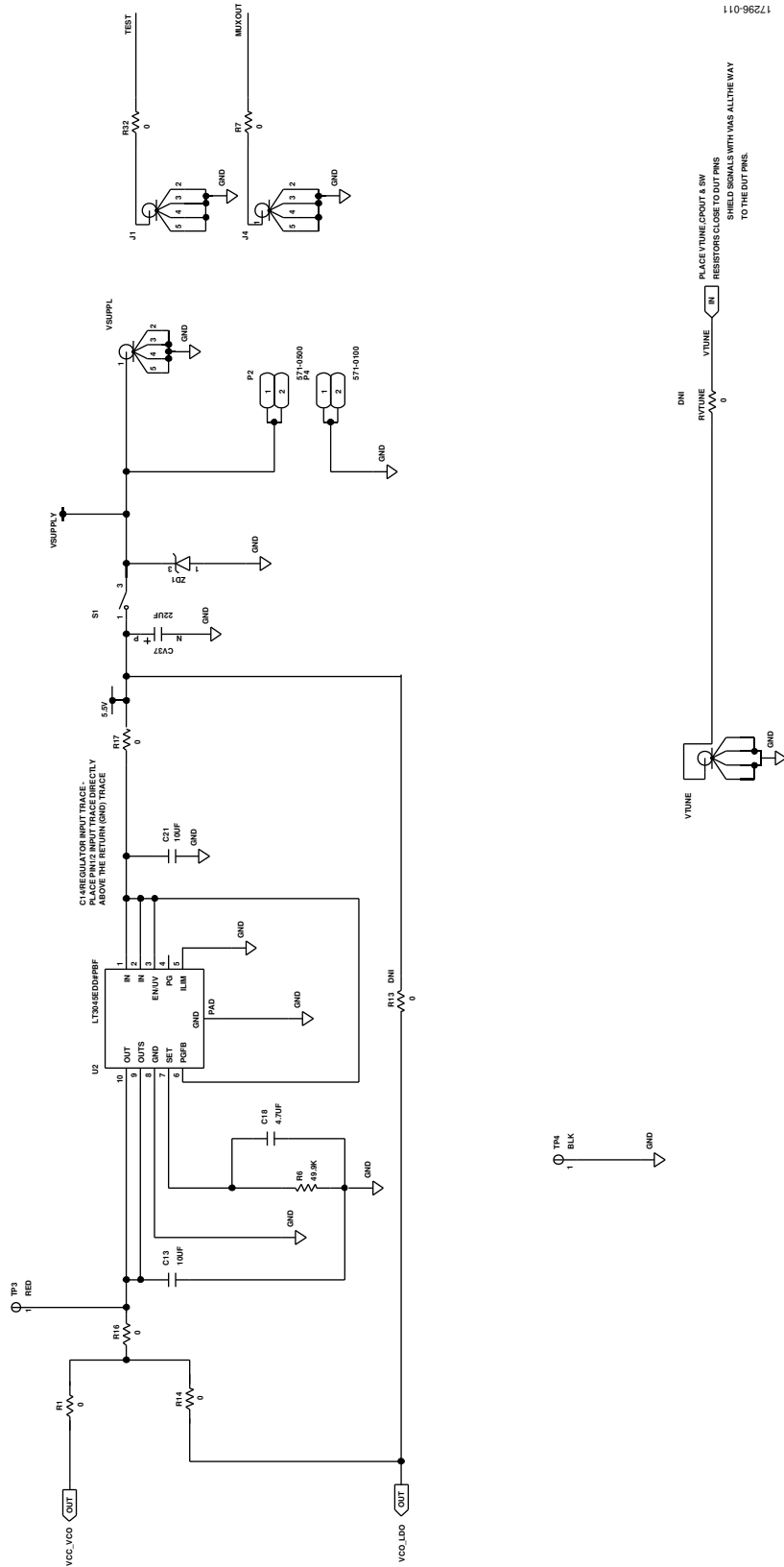
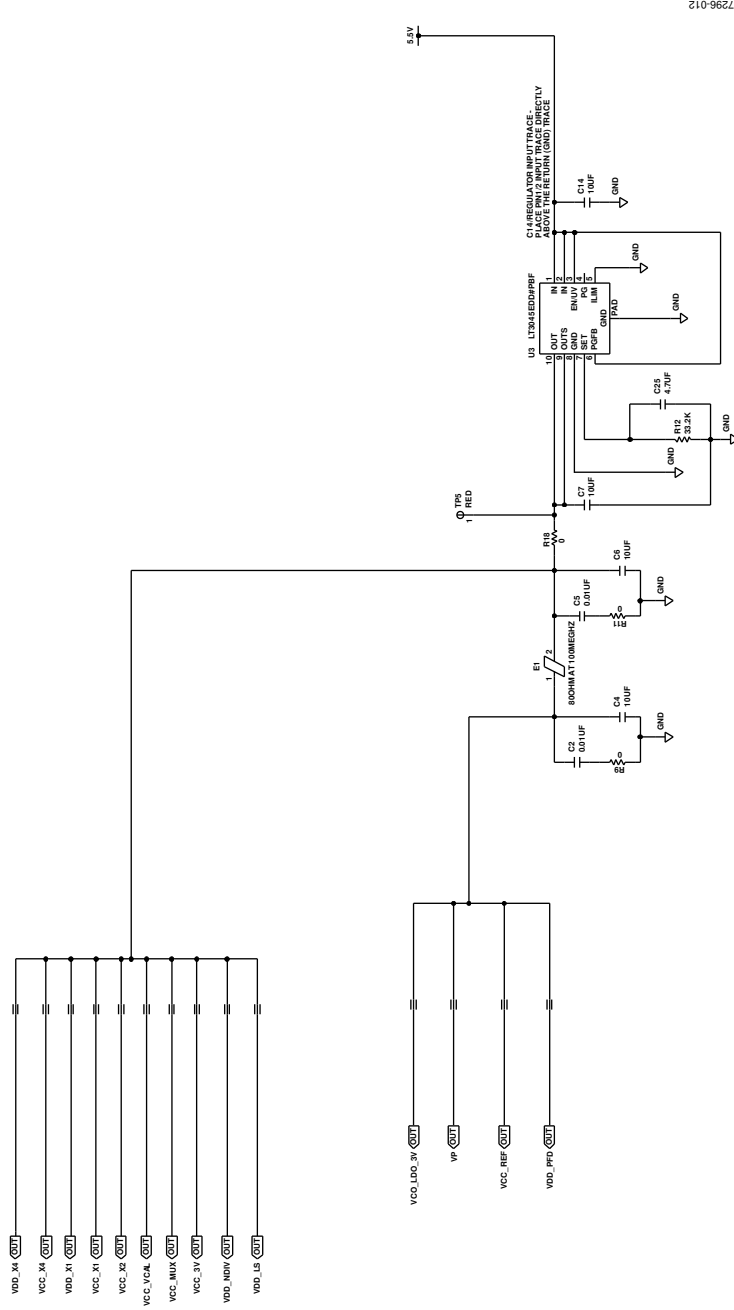

Figure 11. Evaluation Board Schematic, 5V LDO Regulator



17296-012

R1V1 WILL BE USED IF THE REG. OPS NEED TO SHORT TOGETHER.
 R1V2 WILL BE USED IF THE REG. OPS NEED TO SHORT TOGETHER.
 R1V3 WILL BE USED IF THE REG. OPS NEED TO SHORT TOGETHER.

Figure 12. Evaluation Board Schematic, 3.3 V LDO Regulator

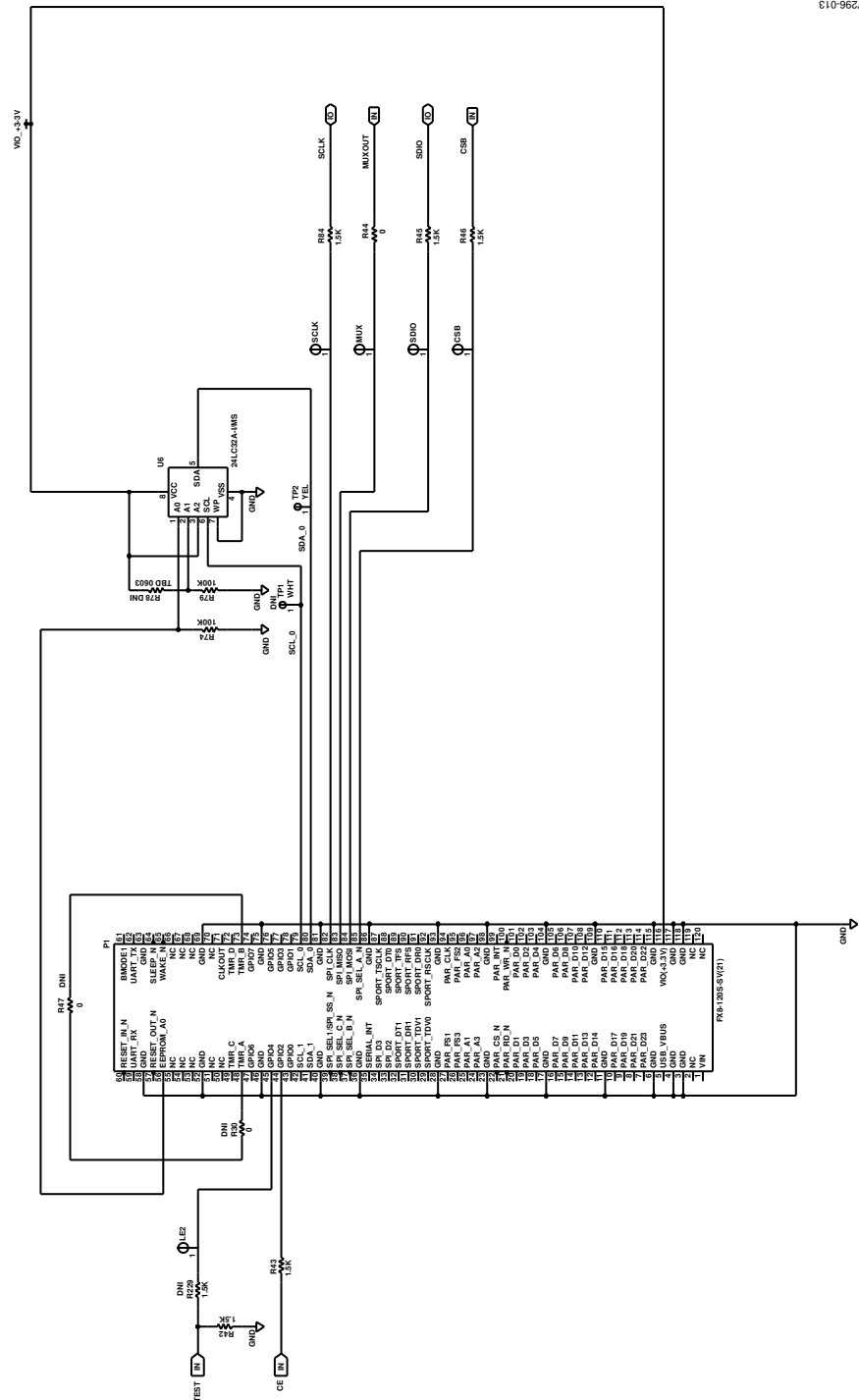

17296-013

Figure 13. Evaluation Board Schematic, Board Connector

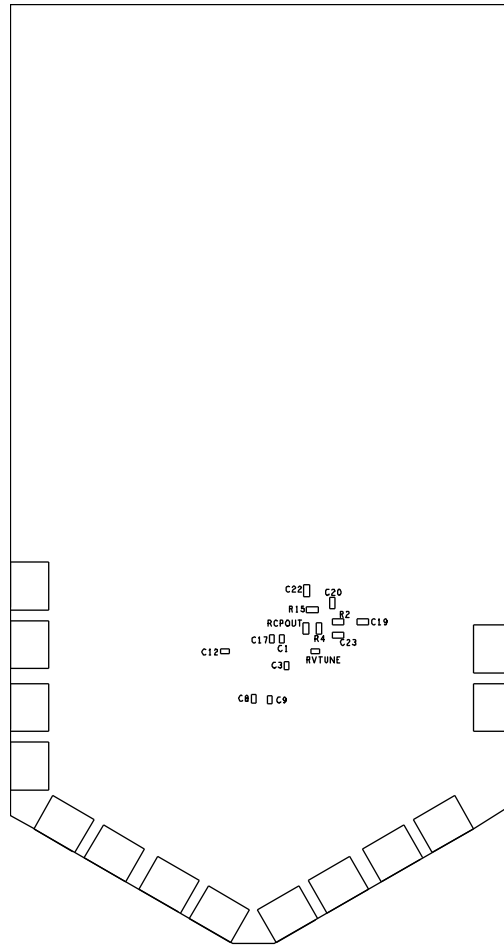

17296-015

Figure 15. Evaluation Board Silk Screen, Bottom Side

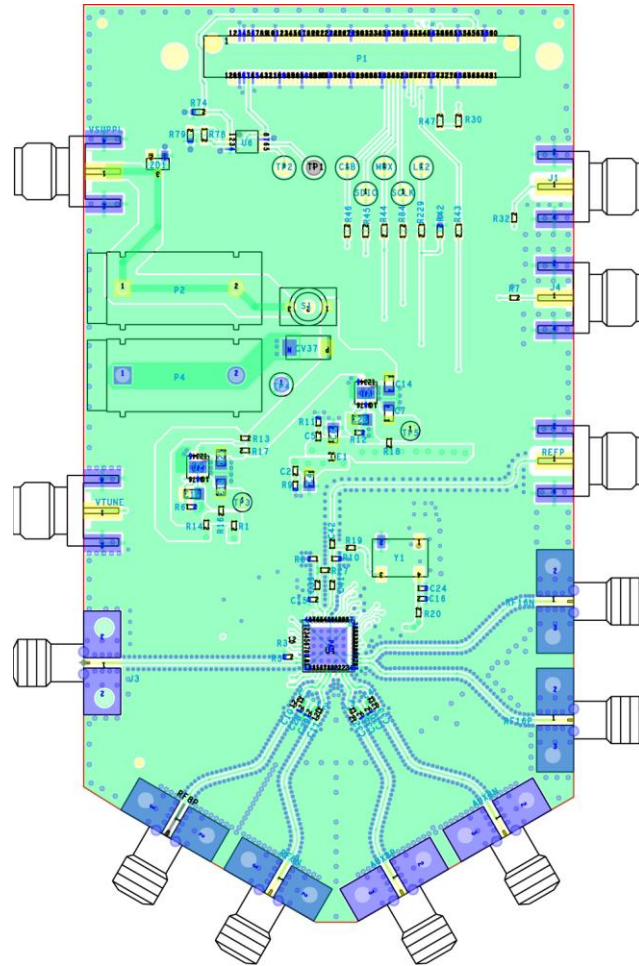

Figure 16. Evaluation Board Layer 1, Primary

17296-016

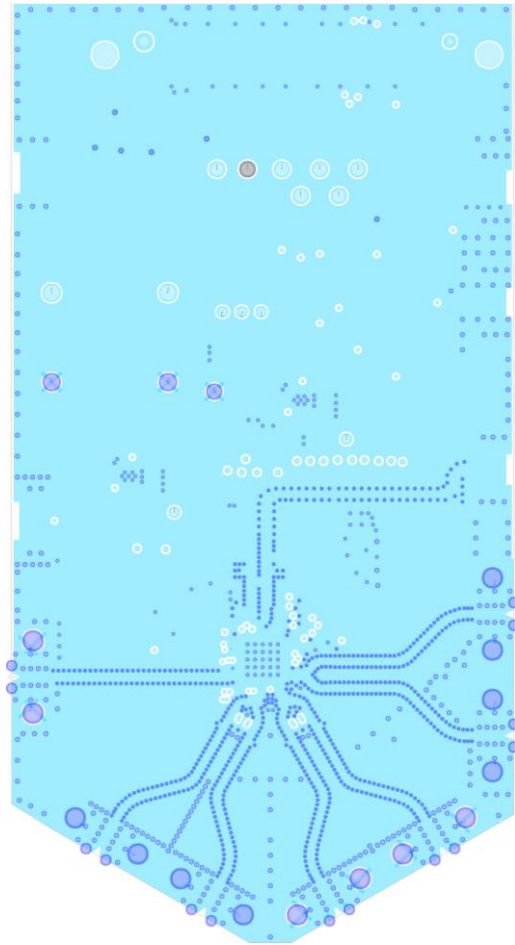
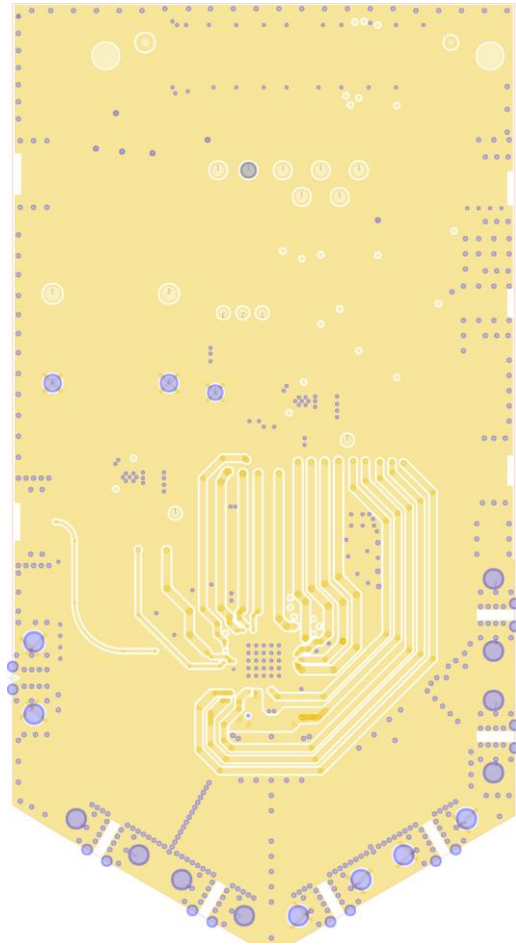
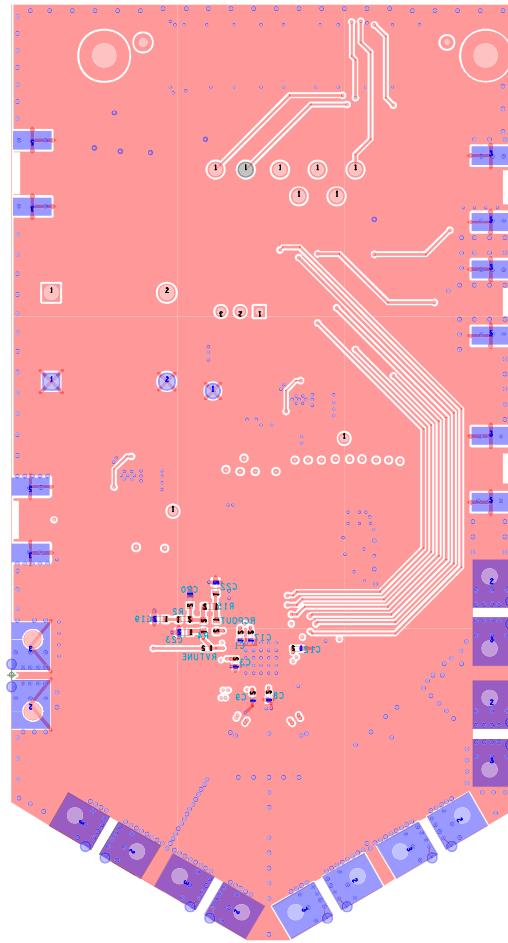

Figure 17. Evaluation Board Layer 2, Ground



17296-018

Figure 18. Evaluation Board Layer 3, Power



17298-019

Figure 19. Evaluation Board Layer 4, Secondary

ORDERING INFORMATION

BILL OF MATERIALS

Table 2.

Reference Designator	Description	Value	Manufacturer	Part Number
AUX8N, AUX8P, RF8N, RF8P, RF16N, RF16P	Printed circuit boards (PCBs), SMA, right angle jack connectors	32K243-40ML5	Rosenberger	32K243-40ML5
C1, C3, C8, C9, C12, C17, C24	Capacitors, ceramic, X6S	1 μ F	TDK	C1005X6S1C105K050BC
C10, C11, C28, C29, C30, C35	Ceramic capacitors, C0G (NP0), general-purpose	10 pF	Murata	GRM0335C1E100JA01D
C4, C6, C7, C13, C14, C21	Ceramic capacitors, X5R, general-purpose	10 μ F	Murata	GRM21BR61C106KE15L
C2, C5, C15, C16	Ceramic capacitors, X7R, general-purpose	0.01 μ F	Murata	GRM155R71E103KA01D
C18, C25	Ceramic capacitors, X5R, general-purpose	4.7 μ F	Murata	GRM21BR61E475KA12L
C19	Ceramic capacitor, X7R 0603	0.018 μ F	AVX	06033C183JAT2A
C20	Chip capacitor, C0G, 0603	220 pF	TDK	C1608C0G1H221J
C23	Capacitor, ceramic, NP0	330 pF	TDK	CGJ3E3C0G2D331J080AA
C32, C33	Multilayer ceramic capacitors (MLCCs), NP0, RF and microwave	10 pF	American Technical Ceramics	400Z100FT16T
C39, C41, C42	Ceramic capacitors, C0G (NP0), general-purpose	1000 pF	Murata	GRM1555C1H102JA01
CSB, LE2, MUX, SCLK, SDIO, TP2	PCB test point connectors	Yellow	Components Corporation	TP-104-01-04
CV37	Tantalum solid electrolytic ceramic	22 μ F	AVX	TCJC226M025R0100
E1	Chip ferrite bead	80 Ω at 100 MHz	Murata	BLM15PX800SN1D
J1, J4, REFP, VSUPPL, VTUNE	PCBs, coaxial, SMA, end launch connectors	142-0701-801	Cinch Connectivity Solutions	142-0701-801
J3	PCB, SMA, right angle jack connector	02K243-40M	Rosenberger	02K243-40M
L1, L2, L3, L4	Chip inductors	7.4 nH	Coilcraft	0302CS-7N4XJLU
P1	PCB, vertical type receptacle, surface-mount device (SMD) connector	FX8-120S-SV(21)	Hirose	FX8-120S-SV(21)
P2	PCB, single socket connector	Red	Deltron	571-0500
P4	PCB, single socket connector	Black	Deltron	571-0100
R1, R7, R9, R11, R14, R16, R17, R18, R19, R20, R32	Thick film, chip resistors	0 Ω	Multicomp	MC00625W040210R
R12	Thick film, chip resistor	33.2 k Ω	Vishay	CRCW040233K2FKED
R15, R44	Film, SMD resistors, 0603	0 Ω	Multicomp	MC0603WG00000T5E-TC
R2	Precision, thin film, chip resistor	400 Ω	Vishay	PAT0603E4000BST1
R27	High frequency, thin film, chip resistor	100 Ω	Vishay	FC0402E1000BST1
R4	Thick film, chip resistor	200 Ω	Multicomp	MC 0.063W 0603 1% 200R
R42, R43, R45, R46, R84	Thick film, chip resistors	1.5 k Ω	Multicomp	MC 0.063W 0603 1% 1K5
R5	High frequency, chip resistor	50 Ω	Vishay	FC0402E50R0BST1
R6	Antisurge, high power, thick film, chip resistor	49.9 k Ω	Vishay	RCS040249K9FKED
R74, R79	Thick film, chip resistors	100 k Ω	Multicomp	MC 0.063W 0603 1% 100K
RCPOUT	Thick film, chip resistor	91 Ω	Yageo	RC0603FR-0791RL
S1	Single-pole single-throw, momentary switch	TT11AGPC104	TE Connectivity	TT11AGPC104
TP3, TP5	PCB test point connectors	Red	Keystone Electronics	5000
TP4	PCB test point connector	Black	Keystone Electronics	5006

Reference Designator	Description	Value	Manufacturer	Part Number
U1	Microwave, wideband synthesizer with integrated VCO	ADF4371BCCZ	Analog Devices, Inc.	ADF4371BCCZ
U2, U3	20 V, 500 mA, ultralow noise, ultrahigh power supply rejection ratio (PSRR), linear regulators	LT3045EDD#PBF	Analog Devices, Inc.	LT3045EDD#PBF
U6	32 kB, serial electronically erasable programmable read-only memory (EEPROM)	24LC32A-I/MS	Microchip Technology	24LC32A-I/MS
Y1	Ultralow, phase noise XO, high density, complementary metal-oxide semiconductor (HCMOS)	100 MHz	Crystek	CCHD-575-50-100.000
ZD1	BZX84C 6.8 V, Zener, SOT-23 diode	BZX84-C6V8	Philips	BZX84-C6V8

**ESD Caution**

ESD (electrostatic discharge) sensitive device. Charged devices and circuit boards can discharge without detection. Although this product features patented or proprietary protection circuitry, damage may occur on devices subjected to high energy ESD. Therefore, proper ESD precautions should be taken to avoid performance degradation or loss of functionality.

Legal Terms and Conditions

By using the evaluation board discussed herein (together with any tools, components documentation or support materials, the "Evaluation Board"), you are agreeing to be bound by the terms and conditions set forth below ("Agreement") unless you have purchased the Evaluation Board, in which case the Analog Devices Standard Terms and Conditions of Sale shall govern. Do not use the Evaluation Board until you have read and agreed to the Agreement. Your use of the Evaluation Board shall signify your acceptance of the Agreement. This Agreement is made by and between you ("Customer") and Analog Devices, Inc. ("ADI"), with its principal place of business at One Technology Way, Norwood, MA 02062, USA. Subject to the terms and conditions of the Agreement, ADI hereby grants to Customer a free, limited, personal, temporary, non-exclusive, non-sublicensable, non-transferable license to use the Evaluation Board FOR EVALUATION PURPOSES ONLY. Customer understands and agrees that the Evaluation Board is provided for the sole and exclusive purpose referenced above, and agrees not to use the Evaluation Board for any other purpose. Furthermore, the license granted is expressly made subject to the following additional limitations: Customer shall not (i) rent, lease, display, sell, transfer, assign, sublicense, or distribute the Evaluation Board; and (ii) permit any Third Party to access the Evaluation Board. As used herein, the term "Third Party" includes any entity other than ADI, Customer, their employees, affiliates and in-house consultants. The Evaluation Board is NOT sold to Customer; all rights not expressly granted herein, including ownership of the Evaluation Board, are reserved by ADI. CONFIDENTIALITY. This Agreement and the Evaluation Board shall all be considered the confidential and proprietary information of ADI. Customer may not disclose or transfer any portion of the Evaluation Board to any other party for any reason. Upon discontinuation of use of the Evaluation Board or termination of this Agreement, Customer agrees to promptly return the Evaluation Board to ADI. ADDITIONAL RESTRICTIONS. Customer may not disassemble, decompile or reverse engineer chips on the Evaluation Board. Customer shall inform ADI of any occurred damages or any modifications or alterations it makes to the Evaluation Board, including but not limited to soldering or any other activity that affects the material content of the Evaluation Board. Modifications to the Evaluation Board must comply with applicable law, including but not limited to the RoHS Directive. TERMINATION. ADI may terminate this Agreement at any time upon giving written notice to Customer. Customer agrees to return to ADI the Evaluation Board at that time. LIMITATION OF LIABILITY. THE EVALUATION BOARD PROVIDED HEREUNDER IS PROVIDED "AS IS" AND ADI MAKES NO WARRANTIES OR REPRESENTATIONS OF ANY KIND WITH RESPECT TO IT. ADI SPECIFICALLY DISCLAIMS ANY REPRESENTATIONS, ENDORSEMENTS, GUARANTEES, OR WARRANTIES, EXPRESS OR IMPLIED, RELATED TO THE EVALUATION BOARD INCLUDING, BUT NOT LIMITED TO, THE IMPLIED WARRANTY OF MERCHANTABILITY, TITLE, FITNESS FOR A PARTICULAR PURPOSE OR NON-INFRINGEMENT OF INTELLECTUAL PROPERTY RIGHTS. IN NO EVENT WILL ADI AND ITS LICENSORS BE LIABLE FOR ANY INCIDENTAL, SPECIAL, INDIRECT, OR CONSEQUENTIAL DAMAGES RESULTING FROM CUSTOMER'S POSSESSION OR USE OF THE EVALUATION BOARD, INCLUDING BUT NOT LIMITED TO LOST PROFITS, DELAY COSTS, LABOR COSTS OR LOSS OF GOODWILL. ADI'S TOTAL LIABILITY FROM ANY AND ALL CAUSES SHALL BE LIMITED TO THE AMOUNT OF ONE HUNDRED US DOLLARS (\$100.00). EXPORT. Customer agrees that it will not directly or indirectly export the Evaluation Board to another country, and that it will comply with all applicable United States federal laws and regulations relating to exports. GOVERNING LAW. This Agreement shall be governed by and construed in accordance with the substantive laws of the Commonwealth of Massachusetts (excluding conflict of law rules). Any legal action regarding this Agreement will be heard in the state or federal courts having jurisdiction in Suffolk County, Massachusetts, and Customer hereby submits to the personal jurisdiction and venue of such courts. The United Nations Convention on Contracts for the International Sale of Goods shall not apply to this Agreement and is expressly disclaimed.

©2019 Analog Devices, Inc. All rights reserved. Trademarks and registered trademarks are the property of their respective owners.
UG17296-0-11/19(0)



www.analog.com