

# Quick Start Guide for Demo Board DC311

---

Demo board DC311 is a 4-phase VRM9.0 power supply providing up to 60A current. Typical applications include power supplies for high speed microprocessors, memory arrays, FPGAs and ASICs. It utilizes one LTC1709EG-9 and one LTC1629 to configure 4-phase operation.

## Specs:

- $V_{IN}$ : 12V typical
- $V_{OUT}$ : Controlled by 5-Bit VID, Default at 1.6V
- $I_{OUT}$ : 60Amax (continuous operation with 100LFM air flow)

## Quick start guide:

Refer to Figure 1 for proper measurement equipment setup and follow the procedure below:

1. Connect the input power source to J1 and J2 using wires capable of handling 12A current.
2. Connect the output load to J3 and J4 using wires with a 70A current rating. If the circuit is to be tested with the constant current mode electronic load, the load current should be preset at low value, say 1A, to start the circuit. Otherwise, the I-V characteristics of the electronic load will interact with the foldback current limiting function of the control IC.
3. Turn on the input power supply and bring the load up to full load after the output voltage reaches the steady state value.

4. **Load transient test:** this demo board has a built-in dynamic load test circuit, which is capable of implementing a 0A to 60A load step.

**The step amplitude, up slope and down slope can be adjusted by R30, R35 and R29, respectively.** The step load current and output voltage may be measured from BNC connectors J5 and J6, respectively. The following procedure is recommended for the load transient test:

- After the output voltage reaches the steady state, set the DC output current to the lower level of the load step.
- Apply  $\pm 12\text{V}$  power to the +12V (E3), PGND (E5) and -12V (E4) terminals and open jumper **JP1**.
- Adjust R30, R35 and R29 to program the step amplitude, up-slope and down-slope of load step, respectively.

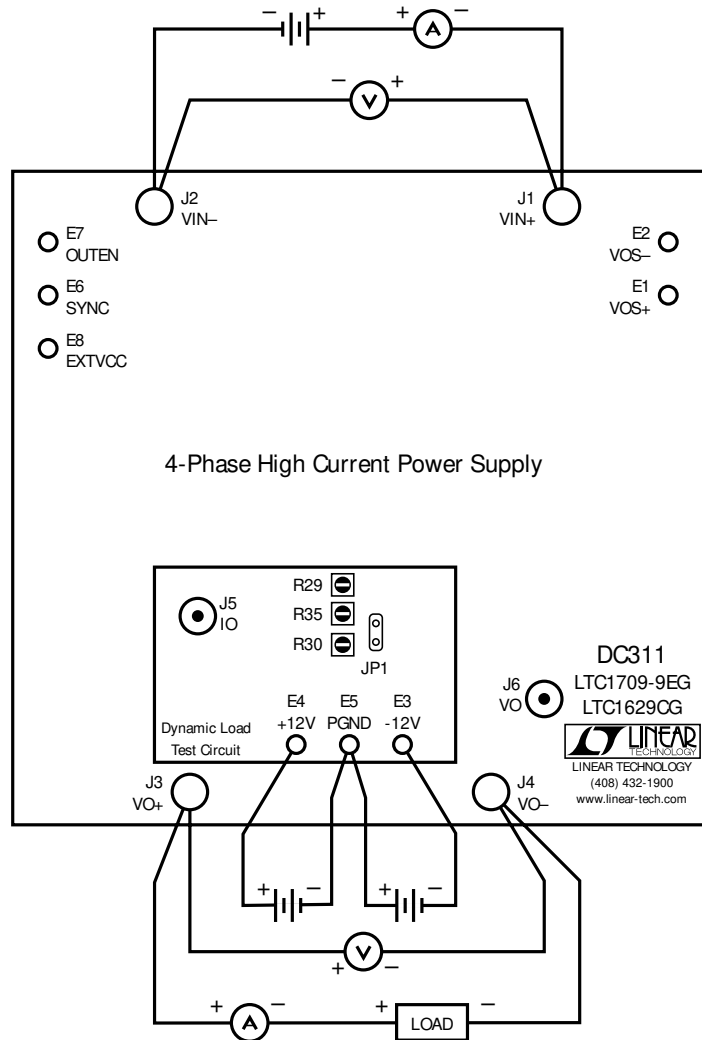

**Figure 1. Proper Measurement Equipment Setup**