

S12R-SSRDSO-NCSL5-001

Gear Tooth Speed Switch

- Ferrous target activated Speed Switch
- 8 to 32V DC Powered
- 150 VAC Normally Closed Form B Relay
- Stainless 12x1mm x 45mm housing
- Shielded 2 pair 22 AWG 105°C PVC, 5 foot



CUSTOMER FOCUSED ENGINEERING + MODULAR DESIGN

Part Description: **S12R-SSRDSO-NCSL5-001**

Housing	Sensor Type & Function	Electrical Option	Connection Type	User Defined Frequency
S = Stainless Steel, Thread Pitch M12x1, 45mm Long	Speed Switch Gear Tooth & Ferrous Targets	Relay Output Normally Closed	SL5 = Ind. Shielded 2 Pair 22AWG -20 to 105°C PVC	Switch Frequency <u>xxx</u> in Hz

Modify, update, or enhance any sensor with our modular features and functionality.

HOUSING - Aluminum, stainless steel, plastic, threaded, flange mount, customer specific

ELECTRICAL - Every sensor function available in various electrical options (NPN, PNP, TTL, etc.)

CONNECTION - Deutsch, Amphenol, many other brands, free end wires, pigtailed, any length

Need a Custom Sensor Solution?... Send us your application specific requirements at sensorso.com

'Steel Gears & Ferrous Target Actuated Speed Switch with Relay Output'

Overspeed, Underspeed, Zero-Speed

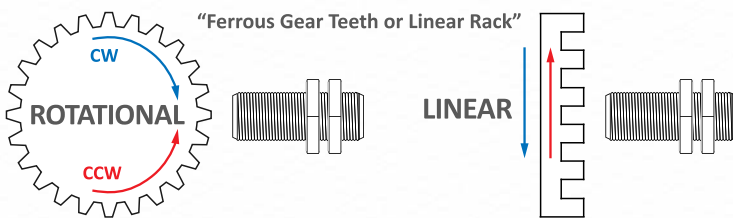

OUTPUTS

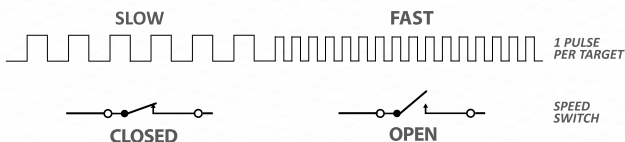

DESCRIPTION

- Speed switch output turns on/off dependent on factory programmed frequency.
- 001 Hz switch point functions as "0 speed" indicator. For other switch speeds contact Sensor Solutions.
- Single channel digital square wave output for resolving actual speed.
- Detects gears and other ferrous targets using Hall Effect Technology
- Capable of detecting 0-32 pitch gears, bolt heads, holes in steel plates, and other ferrous targets
- No orientation required. Use lock nuts to set air gap within range of target

FEATURES

- Ferrous Target Speed Switch
- No Orientation Required
- Add -xxx in Hz to End of PN – contact factory for custom switch point models

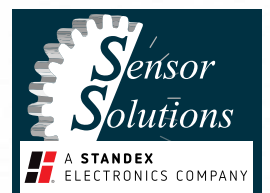

Type - SSG

S12R-SSRDSO-NC SL5-001

Gear Tooth Speed Switch

OTHER OPTIONS

As well as these Ferrous Target Speed Switches, we offer Magnet / Magnet Tape activated Speed Switches, and Gear Tooth Speed Switches designed to work with standard gears. We have options for relay outputs, NPN outputs, and TTL outputs.

Note: Check our website or contact us to discuss any of our magnetic speed, count, and position detection sensors.

Electrical Specifications	Conditions	Min	Max	Unit
Temperature Range	Operating	-40	+110	Deg C
Supply Voltage, Vcc	Over temperature	+8	+32	Volts DC
Supply Current	Into Vcc	6	24	mA
Contact Resistance	Initial	-	0.10	Ohms
Overspeed TRIP Frequency	Relay opens	0.98	1.01	Hz
100% Final Tested at factory				
Underspeed Release Freq.	Relay closes	0.94	0.97	Hz
100% Final Tested at factory				
Relay Closing Bounce Time	T=25C	-	3	mS
ESD (like product qualified)	Nondestructive	-	2000	Volts
EMI (like product qualified)	20k to 1 G Hz	-	20	V / M

Rev C

S12R, Housing, 303 Stainless Steel, M12x1, 45mm Long

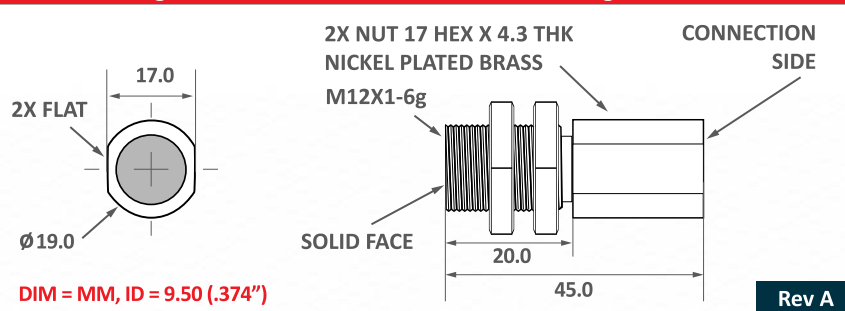

Rev A

SL5, Ind. Shielded 2 Pair 22 AWG -20 to 105°C PVC

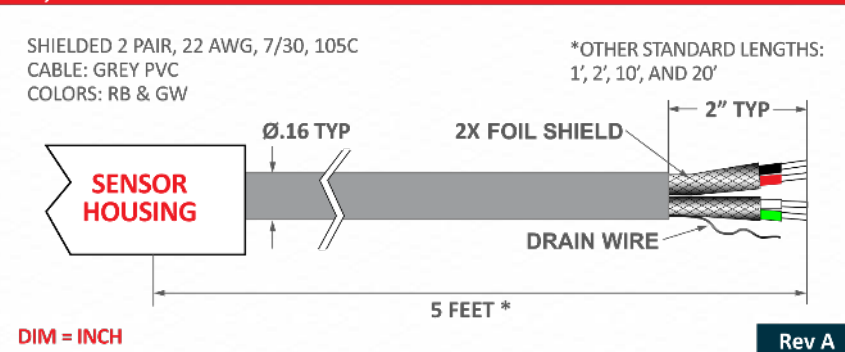

Rev A

Absolute Max Limits	Min	Max	Unit
Supply Voltage, Vcc-Gnd	-16	+32	Volts
Voltage at Relay	-	150	Volts AC
Voltage at Relay	-	120	Volts DC
Switching Current, T = 25C	-	1	Amp
Switching Current, T = 70C	-	.46	Amp
Switching Power, T = 25C	-	30	Watts
Isolation, Surge Voltage Between Supply and Relay	-	1.5	k Volts

Environmental Specifications

Corrosion Resistance	500 hours salt spray ASTM B-117
Installation Torque	23 Foot-Pounds Maximum
Enclosure	Nema 1,3,4,6,13 & IEC IP67
Vibration	10 G's 2 to 2000 Hz Sinusoidal
Mechanical Shock	100 G's, 11 mS Half-Sine

Sensor Characteristics

Output State at 0 Speed: Relay Closed

Air Gap Range, Targets	Min	Typ	Max
Large >1/4" wide and >1/4" apart	.000"	.070"	.140"*
Med. >1/8" wide and >1/8" apart	.000"	.045"	.080"*
Small >1/16" wide and >1/8" apart	.000"	.028"	.030"*
8 Pitch Gear (.393" tooth to tooth)	.000"	.015"	.085"*
TRIP Frequency Accuracy, Relay OPEN	.98%	1.0%	1.01%*
RELEASE Frequency Accuracy, Relay CLOSED	.99%***	1.0%	1.02%
STOP DETECT TIME, Relay closes after sudden stop	1 second (Typ.)		

* Gap the sensor less than MAX GAP.

** Relay is guaranteed OPEN if teeth are passing by faster than 1.02 * Trip Frequency.

***Relay is guaranteed CLOSED if teeth are passing by slower than 0.99 * Release Frequency

Convert RPM to Hz

Over/Under Speed Trip Points are in Hz, pulses per second.

To convert RPM (Revolutions per Minute) to Hz, you need to know the target's pulses per revolution, "N". A 20-tooth target produces 20 pulses, so N=20.

$$\text{Hz} = \text{RPM} * (N / 60). \text{ Or } \text{RPM} = \text{Hz} * (60 / N).$$

Example: For a 20-tooth target and 500 Hz trip point, RPM = 500 * (60 / 20) so the output switches low at 1500 RPM.

Connections Chart

Red	Vcc	Black	Ground
White	Relay Output	Green	Relay Common

SL5-SSRDSO

OTHER MATING CONNECTORS AND CABLES AVAILABLE

S12R-SSRDSO-NC SL5-001

Gear Tooth Speed Switch

Sensor Function

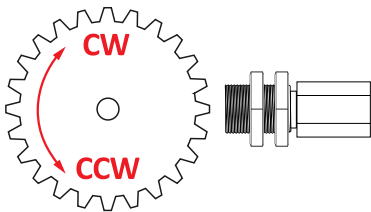

THIS SENSOR WORKS WITH ANY ORIENTATION!

S12R-SSRDSO

Marking

DATE CODE, THIS SURFACE

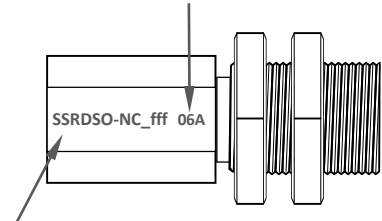

CHARACTERISTIC-OPTION_NC Relay Output
MARKED ON THIS SURFACE
fff = SWITCH FREQUENCY IN Hz #

NC, Relay Output

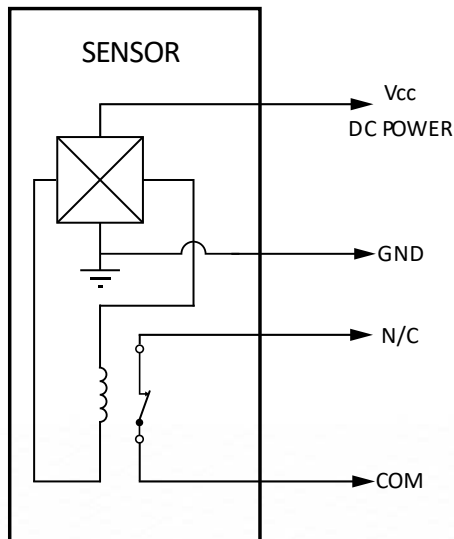

Date Code 'YYM'

YY = YEAR, M = MONTH

A	JAN	D	APR	H	JUL	L	OCT
B	FEB	E	MAY	J	AUG	M	NOV
C	MAR	G	JUN	K	SEP	N	DEC

Handling Instructions

**DO NOT CONTACT
FACE TO FACE**

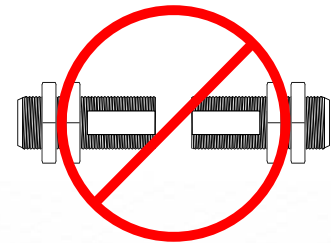

**CONTACT WITH OTHER MAGNETS MAY
REDUCE THE MAXIMUM OPERATING GAP**

Please note: All technical specifications on this series datasheet refer to the standard product range. Modifications in the sense of technical progress are reserved. For general information only. For more specific information, please consult the product datasheet, available upon request.

This series datasheet could contain technical inaccuracies or typographical errors. Changes are periodically made to the information herein. These change will be incorporated in future revisions.

For deviating values, most current specifications and products please contact your nearest sales office.