

FEATURES

- *Guaranteed* 10ppm/°C Temperature Coefficient
- *Guaranteed* 1Ω Maximum Dynamic Impedance
- *Guaranteed* 20μV Maximum Wideband Noise
- Wide Operating Current Range 0.6mA to 15mA

APPLICATIONS

- Transducers
- A/D and D/A Converters
- Calibration Standards
- Instrumentation Reference

DESCRIPTION

The LM129 temperature compensated 6.9V zener references provide excellent stability over time and temperature, very low dynamic impedance and a wide operating current range. The device achieves low dynamic impedance by incorporating a high gain shunt regulator around the zener. The excellent noise performance of the device is achieved by using a “buried zener” design which eliminates surface noise phenomenon associated with ordinary zeners. To serve a wide variety of applications, the LM129 is available in several temperature coefficient grades and two package styles. A 20mA positive current source application is shown below.

LT, LTC and LT are registered trademarks of Linear Technology Corporation.

TYPICAL APPLICATION

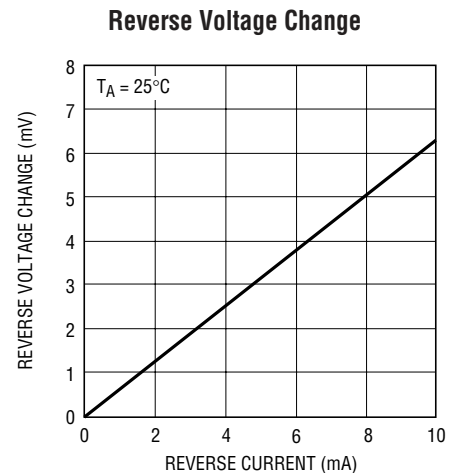
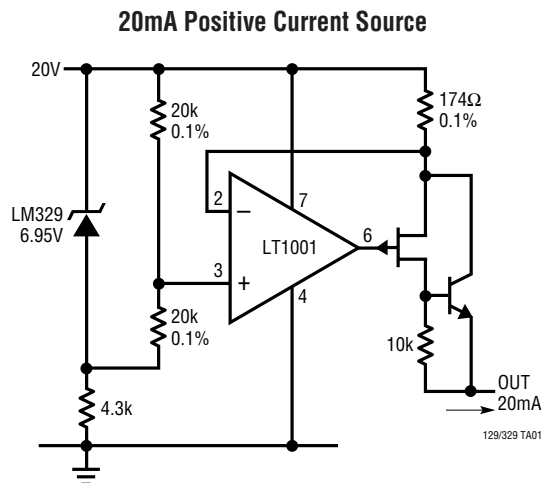

LM129/LM329

ABSOLUTE MAXIMUM RATINGS (Note 1)

Operating Temperature Range	Lead Temperature (Soldering, 10 sec)..... 300°C
LM129 (OBSOLETE) -55°C to 125°C	Reverse Breakdown Current 30mA
LM329 0°C to 70°C	Forward Current 2mA
Storage Temperature Range -65°C to 150°C	

PACKAGE/ORDER INFORMATION

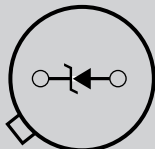
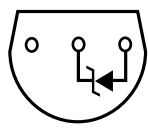
BOTTOM VIEW	ORDER PART NUMBER	BOTTOM VIEW	ORDER PART NUMBER
 <p>H PACKAGE 2-LEAD TO-46 METAL CAN $T_{JMAX} = 150^{\circ}C$, $\theta_{JA} = 440^{\circ}C/W$, $\theta_{JC} = 80^{\circ}C/W$</p> <p>OBSOLETE PACKAGE Consider the Z Package for Alternate Source</p>	LM129AH LM329AH	 <p>Z PACKAGE 3-LEAD PLASTIC TO-92 $T_{JMAX} = 150^{\circ}C$, $\theta_{JA} = 160^{\circ}C/W$</p>	LM329AZ
	LM129BH LM329BH		LM329BZ
	LM129CH LM329CH		LM329CZ
	LM329DH		LM329DZ

Consult LTC Marketing for availability of LM329AZ, LM329CZ and LM329DZ

ELECTRICAL CHARACTERISTICS

The ● denotes the specifications which apply over the full operating temperature range, otherwise specifications are at $T_A = 25^{\circ}C$. (Note 2)

SYMBOL	PARAMETER	CONDITIONS	LM129A/ LM129B/LM129C			LM329A/LM329B/ LM329C/LM329D			UNITS
			MIN	TYP	MAX	MIN	TYP	MAX	
V_Z	Reverse Breakdown Voltage	$T_A = 25^{\circ}C$, $0.6mA \leq I_R \leq 15mA$	6.7	6.9	7.2	6.6	6.9	7.25	V
$\frac{\Delta V_Z}{\Delta I_R}$	Reverse Breakdown Voltage Change with Current	$T_A = 25^{\circ}C$, $0.6mA \leq I_R \leq 15mA$ $1mA \leq I_R \leq 15mA$		9 12	14		9 12	20	mV mV
$\frac{\Delta V_Z}{\Delta Temp}$	Temperature Coefficient	$I_R = 1mA$, LM129A/LM329A ● LM129A/LM329B ● LM129A/LM329C ● LM329D ●		6 15 30	10 20 50		6 15 30 50	10 20 50 100	ppm/°C ppm/°C ppm/°C ppm/°C
	Change in Temperature Coefficient	$1mA \leq I_R \leq 15mA$		1			1		ppm/°C
r_Z	Dynamic Impedance	$T_A = 25^{\circ}C$, $I_R = 1mA$ $1mA \leq I_R \leq 15mA$		0.6 0.8	1		0.8 1	2	Ω Ω
e_n	RMS Noise	$T_A = 25^{\circ}C$, $10Hz \leq f \leq 10kHz$		7	20		7	100	μV
$\frac{\Delta V_Z}{\Delta Time}$	Long Term Stability	$T_A = 45^{\circ}C \pm 0.1^{\circ}C$, $I_R = 1mA \pm 0.3\%$		20			20		ppm/kHr

Note 1: Absolute Maximum Ratings are those values beyond which the life of a device may be impaired.

Note 2: To determine the junction temperature as a function of the ambient temperature, see θ_{JA} for each package.

TYPICAL PERFORMANCE CHARACTERISTICS

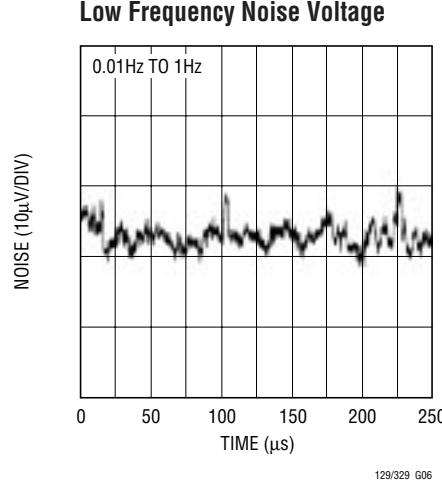
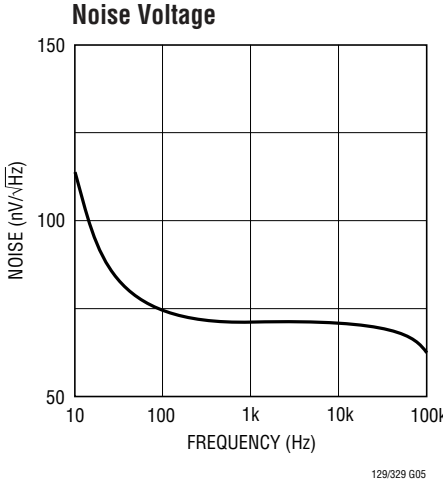
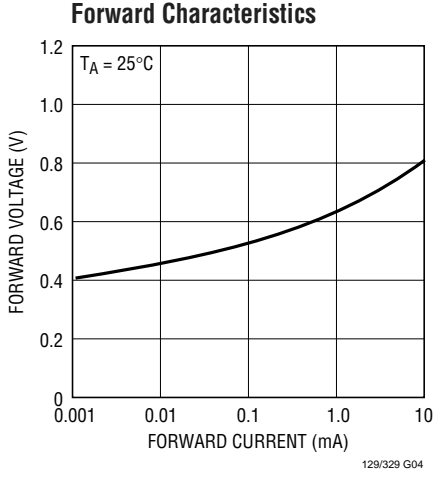
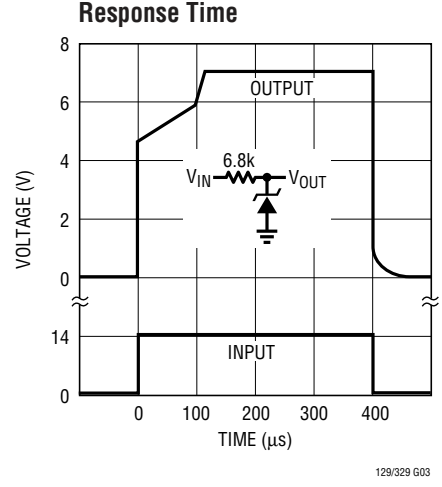
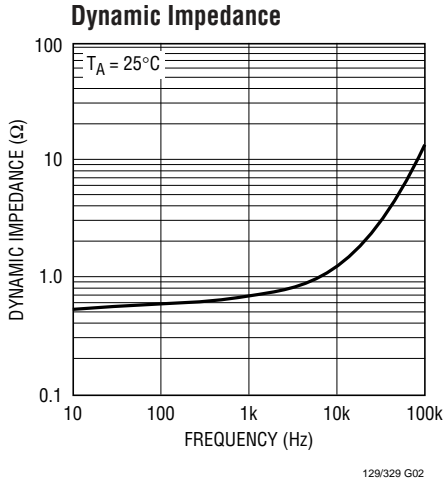
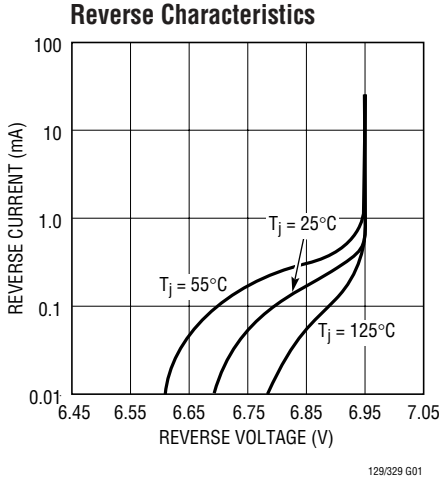

SCHEMATIC DIAGRAM

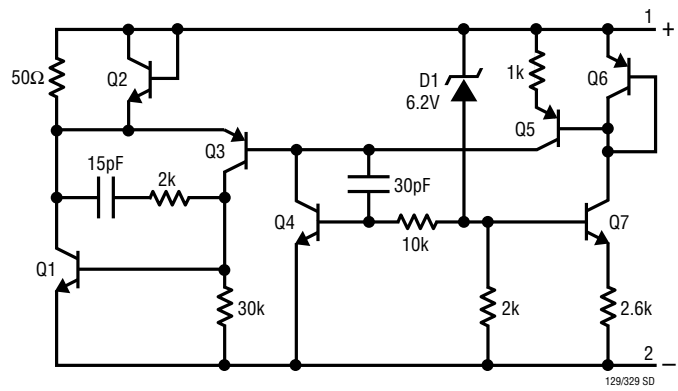

TYPICAL APPLICATIONS

Common Reference

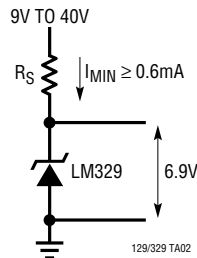

Buffered Reference Using a Single Supply

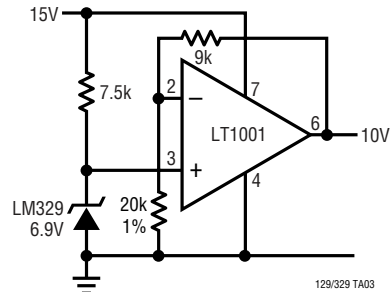

PACKAGE DESCRIPTION

H Package 2-Lead and 3-Lead TO-46 Metal Can (Reference LTC DWG # 05-08-1340)

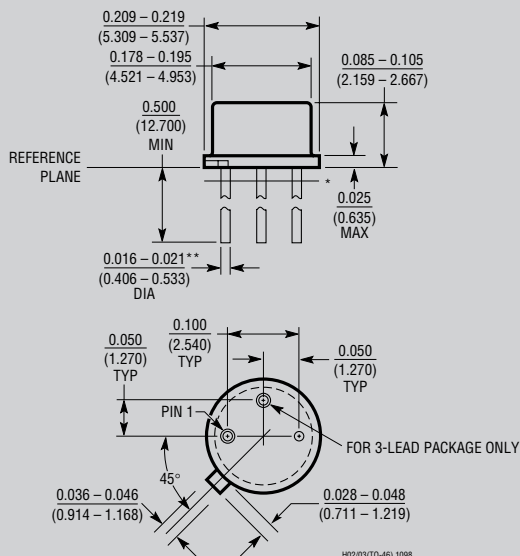

* LEAD DIAMETER IS UNCONTROLLED BETWEEN THE REFERENCE PLANE AND 0.045" BELOW THE REFERENCE PLANE

**FOR SOLDER DIP LEAD FINISH, LEAD DIAMETER IS 0.016 - 0.024 (0.406 - 0.610)

OBSOLETE PACKAGE

Z Package 3-Lead Plastic TO-92 (Similar to TO-226) (Reference LTC DWG # 05-08-1410)

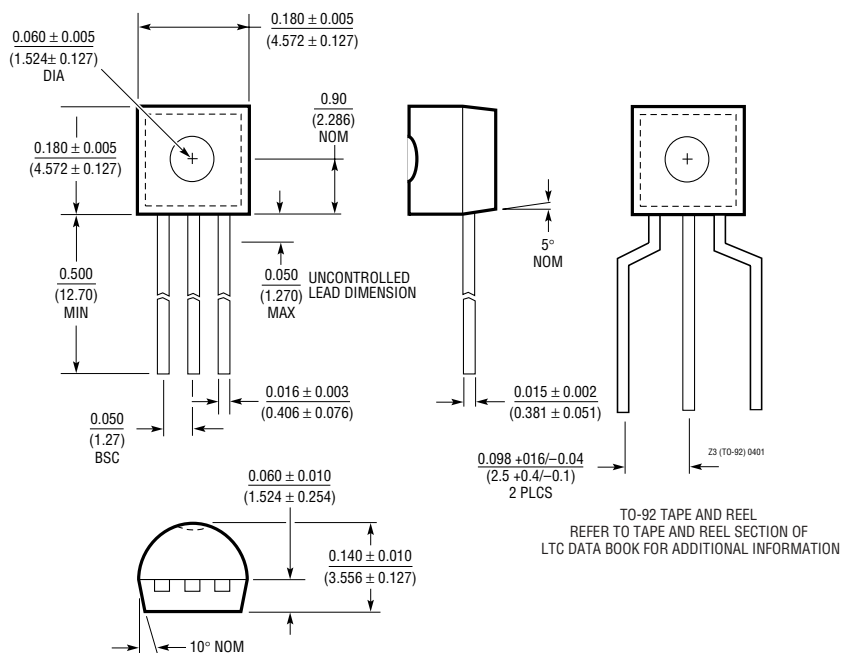

RELATED PARTS

PART NUMBER	DESCRIPTION	COMMENTS
LT1460	Micropower, Precise Series Reference	10ppm/°C, Output Voltages: 2.5V, 3V, 3.3V, 5V, 10V
LT1634	0.05% Accurate, 10ppm/°C, Shunt Reference	Output Voltages: 1.25V, 2.5V, 4.096V, 5V