

A								A
---	--	--	--	--	--	--	--	---

NOTES:

- Plunger: Brass, 20μ" MIN Au over, 50μ" MIN Ni over
- Barrel : Brass, 3μ" ,MIN Au over, 50μ" MIN Ni over
- Spring : Stainless Steel

Mechanical Characteristics:

- Spring Force : 85g ± 20% at Working Length
- Mechanical Life : 1,000,000 cycle

Electrical Characteristics:

- Current Rating : 2A
- Contact Resistance : 20 mΩ Max
- Operating Temperature range : -55~125° C
- Packing: PE Bag

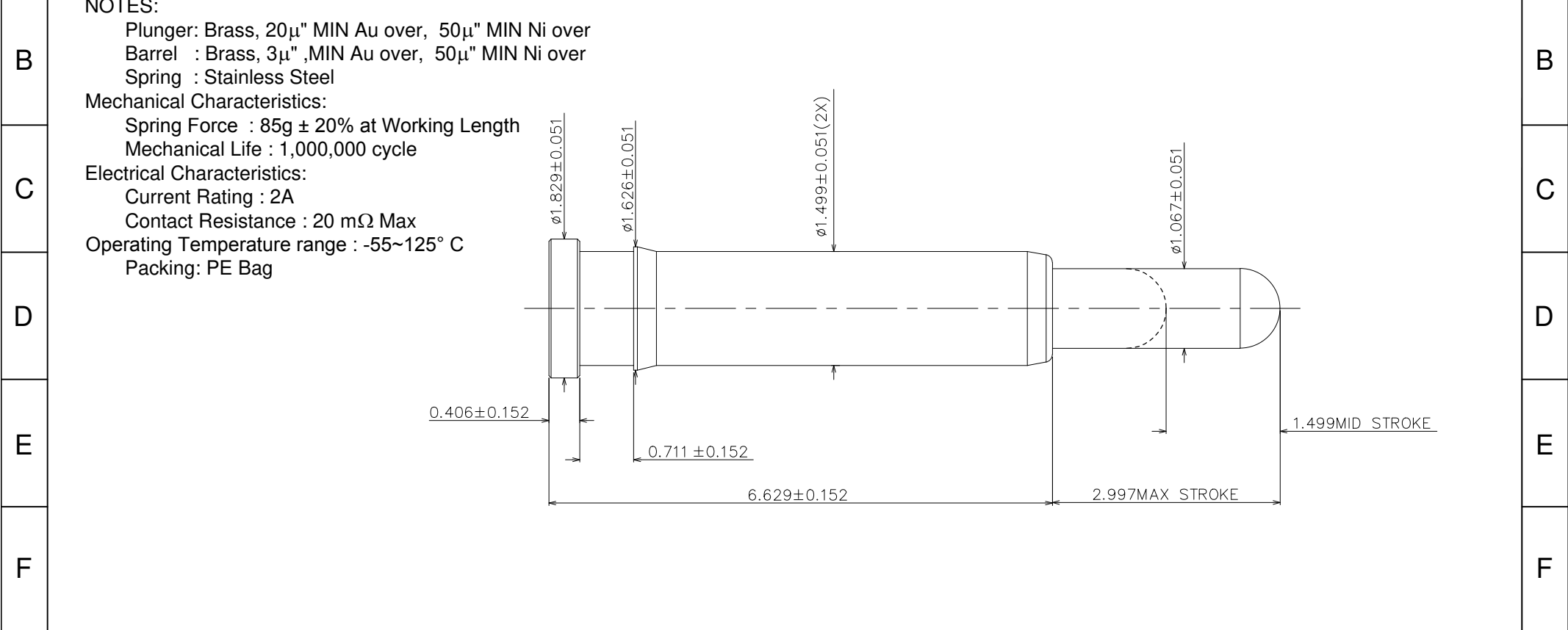

RoHS compliant
Unit: mm

Scale	Free						Date	Name	Customer-No.
TOLERANCE							Drawn	28.03.2018	Tom
X.X	±0.20						Approved	28.03.2018	Winnie
X.XX	±0.10								ASSMANN WSW-No. A-CSL-S-020-B6
X.XXX	±0.08								
DIM	TOL						ASSMANN WSW components		Drawing-No.
Angle	±3°	ⓐ	Drawn	28.03.2018	Tom	ASSMANN WSW components		Replace	Sheet
Angle	TOL	Id.	Modification	Date	Name				