



MICROCHIP

**MCP2200
Breakout Module
User's Guide**

Note the following details of the code protection feature on Microchip devices:

- Microchip products meet the specification contained in their particular Microchip Data Sheet.
- Microchip believes that its family of products is one of the most secure families of its kind on the market today, when used in the intended manner and under normal conditions.
- There are dishonest and possibly illegal methods used to breach the code protection feature. All of these methods, to our knowledge, require using the Microchip products in a manner outside the operating specifications contained in Microchip's Data Sheets. Most likely, the person doing so is engaged in theft of intellectual property.
- Microchip is willing to work with the customer who is concerned about the integrity of their code.
- Neither Microchip nor any other semiconductor manufacturer can guarantee the security of their code. Code protection does not mean that we are guaranteeing the product as "unbreakable."

Code protection is constantly evolving. We at Microchip are committed to continuously improving the code protection features of our products. Attempts to break Microchip's code protection feature may be a violation of the Digital Millennium Copyright Act. If such acts allow unauthorized access to your software or other copyrighted work, you may have a right to sue for relief under that Act.

Information contained in this publication regarding device applications and the like is provided only for your convenience and may be superseded by updates. It is your responsibility to ensure that your application meets with your specifications. MICROCHIP MAKES NO REPRESENTATIONS OR WARRANTIES OF ANY KIND WHETHER EXPRESS OR IMPLIED, WRITTEN OR ORAL, STATUTORY OR OTHERWISE, RELATED TO THE INFORMATION, INCLUDING BUT NOT LIMITED TO ITS CONDITION, QUALITY, PERFORMANCE, MERCHANTABILITY OR FITNESS FOR PURPOSE. Microchip disclaims all liability arising from this information and its use. Use of Microchip devices in life support and/or safety applications is entirely at the buyer's risk, and the buyer agrees to defend, indemnify and hold harmless Microchip from any and all damages, claims, suits, or expenses resulting from such use. No licenses are conveyed, implicitly or otherwise, under any Microchip intellectual property rights.

Trademarks

The Microchip name and logo, the Microchip logo, dsPIC, KEELOQ, KEELOQ logo, MPLAB, PIC, PICmicro, PICSTART, PIC³² logo, rfPIC and UNI/O are registered trademarks of Microchip Technology Incorporated in the U.S.A. and other countries.

FilterLab, Hampshire, HI-TECH C, Linear Active Thermistor, MXDEV, MXLAB, SEEVAL and The Embedded Control Solutions Company are registered trademarks of Microchip Technology Incorporated in the U.S.A.

Analog-for-the-Digital Age, Application Maestro, chipKIT, chipKIT logo, CodeGuard, dsPICDEM, dsPICDEM.net, dsPICworks, dsSPEAK, ECAN, ECONOMONITOR, FanSense, HI-TIDE, In-Circuit Serial Programming, ICSP, Mindi, MiWi, MPASM, MPLAB Certified logo, MPLIB, MPLINK, mTouch, Omniscient Code Generation, PICC, PICC-18, PICDEM, PICDEM.net, PCKit, PICtail, REAL ICE, rfLAB, Select Mode, Total Endurance, TSHARC, UniWinDriver, WiperLock and ZENA are trademarks of Microchip Technology Incorporated in the U.S.A. and other countries.

SQTP is a service mark of Microchip Technology Incorporated in the U.S.A.

All other trademarks mentioned herein are property of their respective companies.

© 2012, Microchip Technology Incorporated, Printed in the U.S.A., All Rights Reserved.

 Printed on recycled paper.

ISBN: 978-1-62076-297-4

Microchip received ISO/TS-16949:2009 certification for its worldwide headquarters, design and wafer fabrication facilities in Chandler and Tempe, Arizona; Gresham, Oregon and design centers in California and India. The Company's quality system processes and procedures are for its PIC[®] MCUs and dsPIC[®] DSCs, KEELOQ[®] code hopping devices, Serial EEPROMs, microperipherals, nonvolatile memory and analog products. In addition, Microchip's quality system for the design and manufacture of development systems is ISO 9001:2000 certified.

QUALITY MANAGEMENT SYSTEM
CERTIFIED BY DNV
== ISO/TS 16949:2009 ==

Table of Contents

Preface	5
Introduction.....	5
Document Layout	5
Conventions Used in this Guide	6
Recommended Reading.....	7
The Microchip Web Site	7
Customer Support	7
Document Revision History	7
 Chapter 1. Product Overview	
1.1 Introduction	9
1.2 What Is the MCP2200 Breakout Module?	9
1.3 What the MCP2200 Breakout Module Kit Contains	9
 Chapter 2. Installation and Operation	
2.1 Introduction	11
2.2 Board Setup	11
2.3 Board Operation	12
2.4 MCP2200 Typical Usage Scenarios	13
 Appendix A. Schematic and Layouts	
A.1 Introduction	15
A.2 Board – Schematic	16
A.3 Board – Top Silk	17
A.4 Board – Top Silk and Pads	18
A.5 Board – Top Copper	19
A.6 Board – Bottom Silk	20
A.7 Board – Bottom Silk and Pads	21
A.8 Board – Bottom Copper	22
 Appendix B. Bill of Materials (BOM)	
Worldwide Sales and Service	24

EU Declaration of Conformity

Manufacturer: Microchip Technology Inc.
2355 W. Chandler Blvd.
Chandler, Arizona, 85224-6199
USA

This declaration of conformity is issued by the manufacturer.

The development/evaluation tool is designed to be used for research and development in a laboratory environment. This development/evaluation tool is not a Finished Appliance, nor is it intended for incorporation into Finished Appliances that are made commercially available as single functional units to end users under EU EMC Directive 2004/108/EC and as supported by the European Commission's Guide for the EMC Directive 2004/108/EC (8th February 2010).

This development/evaluation tool complies with EU RoHS2 Directive 2011/65/EU.

For information regarding the exclusive, limited warranties applicable to Microchip products, please see Microchip's standard terms and conditions of sale, which are printed on our sales documentation and available at www.microchip.com.

Signed for and on behalf of Microchip Technology Inc. at Chandler, Arizona, USA



Derek Carlson
VP Development Tools

07-Dec-11
Date

Preface

NOTICE TO CUSTOMERS

All documentation becomes dated, and this manual is no exception. Microchip tools and documentation are constantly evolving to meet customer needs, so some actual dialogs and/or tool descriptions may differ from those in this document. Please refer to our web site (www.microchip.com) to obtain the latest documentation available.

Documents are identified with a “DS” number. This number is located on the bottom of each page, in front of the page number. The numbering convention for the DS number is “DSXXXXA”, where “XXXX” is the document number and “A” is the revision level of the document.

For the most up-to-date information on development tools, see the MPLAB® IDE online help. Select the Help menu, and then Topics to open a list of available online help files.

INTRODUCTION

This chapter contains general information that will be useful to know before using the MCP2200 Breakout Module. Items discussed in this chapter include:

- Document Layout
- Conventions Used in this Guide
- Recommended Reading
- The Microchip Web Site
- Customer Support
- Document Revision History

DOCUMENT LAYOUT

This document describes how to use the MCP2200 Breakout Module board. The manual layout is as follows:

- **Chapter 1. “Product Overview”** – Important information about the MCP2200 Breakout Module
- **Chapter 2. “Installation and Operation”** – Covers the initial set-up of this board, required tools and board operation
- **Appendix A. “Schematic and Layouts”** – Shows the schematic and board layouts for the MCP2200 Breakout Module
- **Appendix B. “Bill of Materials (BOM)”** – Lists the parts used to populate the MCP2200 Breakout Module

MCP2200 Breakout Module User's Guide

CONVENTIONS USED IN THIS GUIDE

This manual uses the following documentation conventions:

DOCUMENTATION CONVENTIONS

Description	Represents	Examples
Arial font:		
Italic characters	Referenced books	<i>MPLAB[®] IDE User's Guide</i>
	Emphasized text	...is the <i>only</i> compiler...
Initial caps	A window	the Output window
	A dialog	the Settings dialog
	A menu selection	select Enable Programmer
Quotes	A field name in a window or dialog	"Save project before build"
Underlined, italic text with right angle bracket	A menu path	<u><i>File>Save</i></u>
Bold characters	A dialog button	Click OK
	A tab	Click the Power tab
N'Rnnnn	A number in verilog format, where N is the total number of digits, R is the radix and n is a digit.	4'b0010, 2'hF1
Text in angle brackets < >	A key on the keyboard	Press <Enter>, <F1>
Courier New font:		
Plain Courier New	Sample source code	#define START
	Filenames	autoexec.bat
	File paths	c:\mcc18\h
	Keywords	_asm, _endasm, static
	Command-line options	-Opa+, -Opa-
	Bit values	0, 1
	Constants	0xFF, 'A'
Italic Courier New	A variable argument	<i>file.o</i> , where <i>file</i> can be any valid filename
Square brackets []	Optional arguments	mcc18 [options] <i>file</i> [options]
Curly brackets and pipe character: { }	Choice of mutually exclusive arguments; an OR selection	errorlevel {0 1}
Ellipses...	Replaces repeated text	var_name [, var_name...]
	Represents code supplied by user	void main (void) { ... }

RECOMMENDED READING

This user's guide describes how to use the MCP2200 Breakout Module. Another useful document is listed below. The following Microchip document is available and recommended as a supplemental reference resource.

- **MCP2200 Data Sheet - “USB 2.0 to UART Protocol Converter with GPIO” (DS22228)**

THE MICROCHIP WEB SITE

Microchip provides online support via our web site at www.microchip.com. This web site is used as a means to make files and information easily available to customers. Accessible by using your favorite Internet browser, the web site contains the following information:

- **Product Support** – Data sheets and errata, application notes and sample programs, design resources, user's guides and hardware support documents, latest software releases and archived software
- **General Technical Support** – Frequently Asked Questions (FAQs), technical support requests, online discussion groups, Microchip consultant program member listing
- **Business of Microchip** – Product selector and ordering guides, latest Microchip press releases, listing of seminars and events, listings of Microchip sales offices, distributors and factory representatives

CUSTOMER SUPPORT

Users of Microchip products can receive assistance through several channels:

- Distributor or Representative
- Local Sales Office
- Field Application Engineer (FAE)
- Technical Support

Customers should contact their distributor, representative or field application engineer (FAE) for support. Local sales offices are also available to help customers. A listing of sales offices and locations is included in the back of this document.

Technical support is available through the web site at:
<http://www.microchip.com/support>.

DOCUMENT REVISION HISTORY

Revision A (May 2012)

- Initial Release of this Document.

MCP2200 Breakout Module User's Guide

NOTES:

Chapter 1. Product Overview

1.1 INTRODUCTION

This chapter provides an overview of the MCP2200 Breakout Module and covers the following topics:

- What Is the MCP2200 Breakout Module?
- What the MCP2200 Breakout Module Kit Contains

1.2 WHAT IS THE MCP2200 BREAKOUT MODULE?

The MCP2200 Breakout Module is a development and evaluation platform for the USB-to-UART (Universal Serial Bus-to-Universal Asynchronous Receiver/Transmitter) serial converter MCP2200 device. The module is comprised of a single Dual In-Line Package (DIP) form-factor board.

The MCP2200 Breakout Module has the following features:

- UART Tx and Rx signals
- UART RTS and CTS signals
- 8 General Purpose (GP) lines - configurable for GPIO or dedicated function operation
- User selectable power supply of 3.3V or 5V (up to 500 mA) by using a jumper
- DIP form-factor (0.6 inches overall row spacing between pins)
- PICkit™ Serial Analyzer header – used for UART communication only

A Windows®-based PC software was created to help with the evaluation/demonstration of the MCP2200 device as a USB-to-UART protocol converter. It allows I/O control and custom device configuration. The software is downloadable from the board web page on www.microchip.com.

1.3 WHAT THE MCP2200 BREAKOUT MODULE KIT CONTAINS

The MCP2200 Breakout Module kit includes:

- MCP2200 Breakout Module (ADM00393)
- Mini-USB cable
- Important Information Sheet

MCP2200 Breakout Module User's Guide

NOTES:

Chapter 2. Installation and Operation

2.1 INTRODUCTION

The MCP2200 Breakout Module is designed to demonstrate the device as an USB-to-UART protocol converter solution.

The module is comprised of a single board and has the following features:

- Small plug-in board with DIP form factor (0.6 inches overall row spacing between pins)
- Mini-USB connector
- Access to the UART signals (Tx, Rx, RTS and CTS) and all GP signals
- PICKit™ Serial Analyzer compatible header
- 3.3 or 5V jumper selectable VDD; the breakout board can be used to supply up to 100 mA to the rest of the system. The board already provides a signal trace between the VDD and the 3.3V rail. For systems requiring a 5V V_{DD} power supply, the V_{DD} header must be mounted on the board. A jumper will close the middle pin and the 5V pin.

2.2 BOARD SETUP

Follow these steps to set up the MCP2200 Breakout Module:

1. Download the support material (PC applications and DLL libraries) that can be found on the board's web page, on the Microchip web site.
2. Attach the MCP2200 Breakout Module to the system that requires the USB-to-UART conversion, using a DIP adapter or the PICKit™ Serial Analyzer header.
3. Plug the MCP2200 Breakout Module to a PC via a USB cable.
4. In the dialog window that appears, browse for `MCP2200.inf` to install the driver.

The board is now set up for operation. Optional steps include the following:

5. Install the downloaded PC software.
6. Start the demo application developed for the board, or a hyperterminal-like application, in order to get access to the virtual COM port created by the PC for the MCP2200 device.

MCP2200 Breakout Module User's Guide

FIGURE 2-1: BREAKOUT BOARD LAYOUT

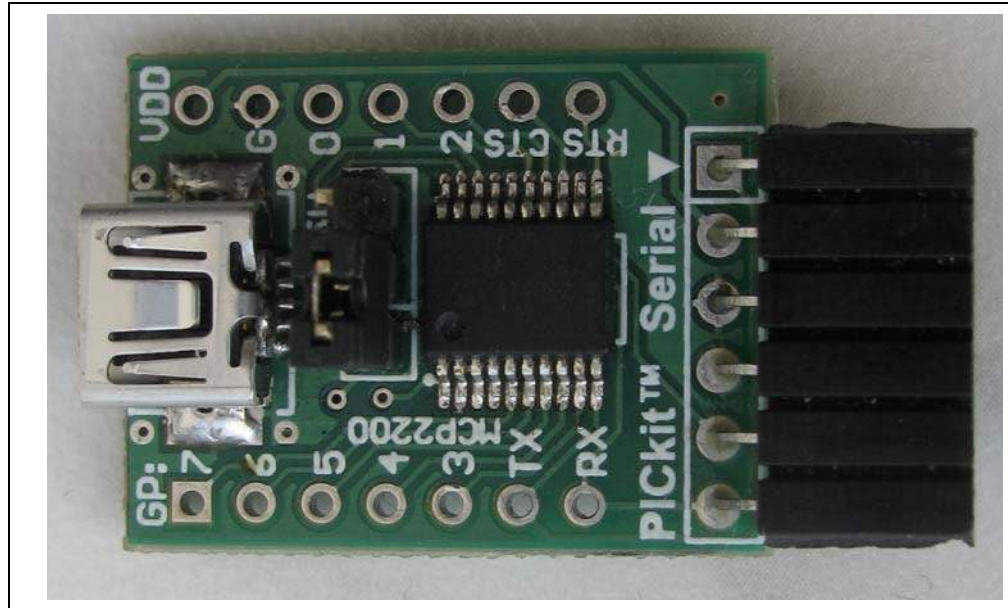

2.3 BOARD OPERATION

The MCP2200 device is detected by a Windows[®]-based PC host as a composite device. The accompanying software can be used to exercise the board's features and also provides a reference point for users that want to design their own applications based on the MCP2200 device.

2.3.1 MCP2200 Breakout Module Operation

The MCP2200 Breakout Module can be used with a UART-based system. The breakout board eases the USB support addition.

The board has the following features:

- UART signals (Tx, Rx, RTS and CTS)
- 8 GP signals that can be configured for:
 - GPIO functionality (digital input or output pins)
 - Dedicated function pins (signaling import system states, such as USB Configured, USB Suspend)
- Jumper selectable power supply: 3.3 or 5V (up to 500 mA)
- PICKIT™ Serial Analyzer header - the board can be directly plugged into systems that have this type of header. The MCP2200 Breakout Module provides the UART-to-USB access.
- DIP form-factor (0.6 inches overall row spacing between pins)

By using the provided software and libraries, the user can create personalized PC applications, using the breakout board as an USB-to-UART protocol converter.

2.4 MCP2200 TYPICAL USAGE SCENARIOS

MCP2200 can be used in systems where a UART bus is available. The MCP2200 enables the USB connection to a UART-based system.

FIGURE 2-2: MCP2200 TYPICAL USAGE DIAGRAM

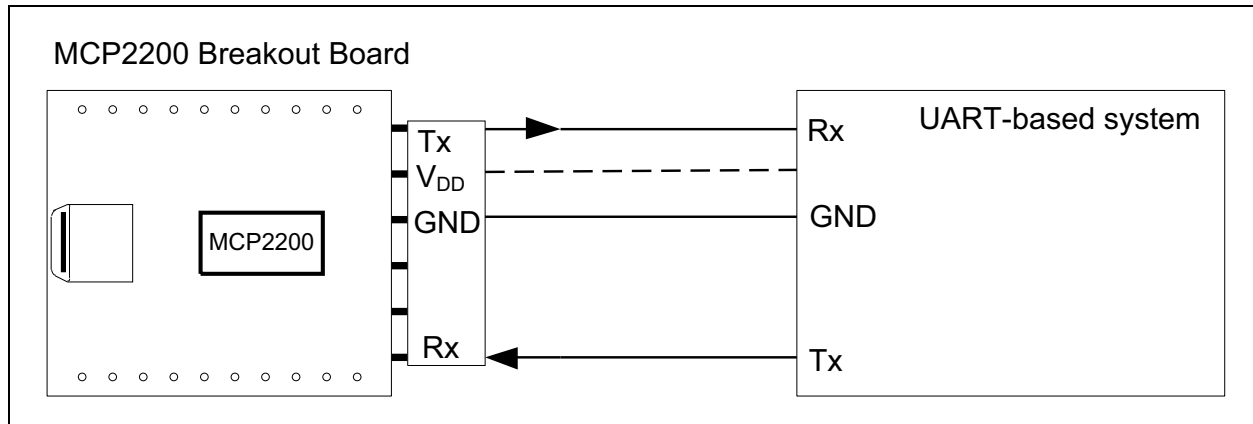

MCP2200 Breakout Module User's Guide

NOTES:



MCP2200 BREAKOUT MODULE USER'S GUIDE

Appendix A. Schematic and Layouts

A.1 INTRODUCTION

This appendix contains the following schematics and layouts for the MCP2200 Breakout Module:

- Board – Schematic
- Board – Top Silk
- Board – Top Silk and Pads
- Board – Top Copper
- Board – Bottom Silk
- Board – Bottom Silk and Pads
- Board – Bottom Copper

A.2 BOARD – SCHEMATIC

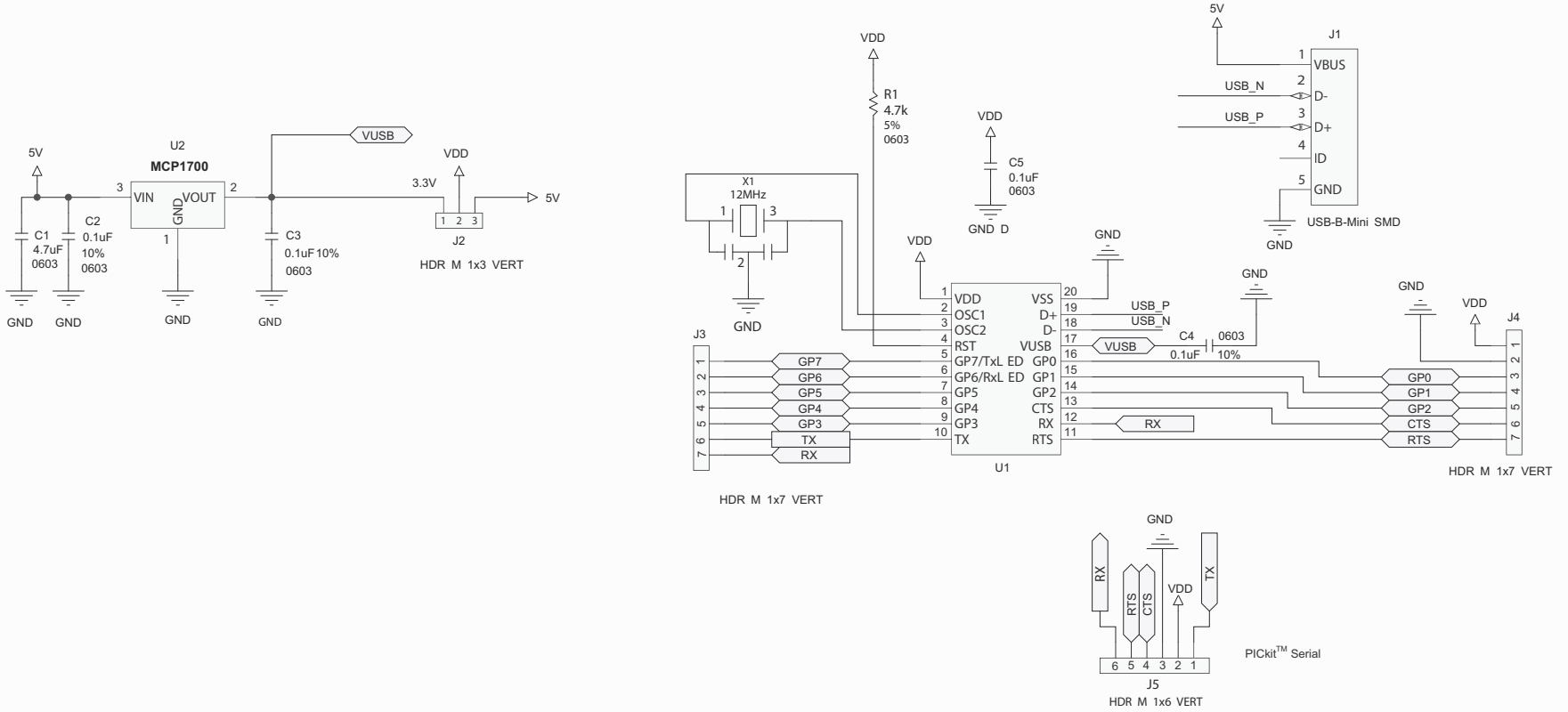

A.3 BOARD – TOP SILK

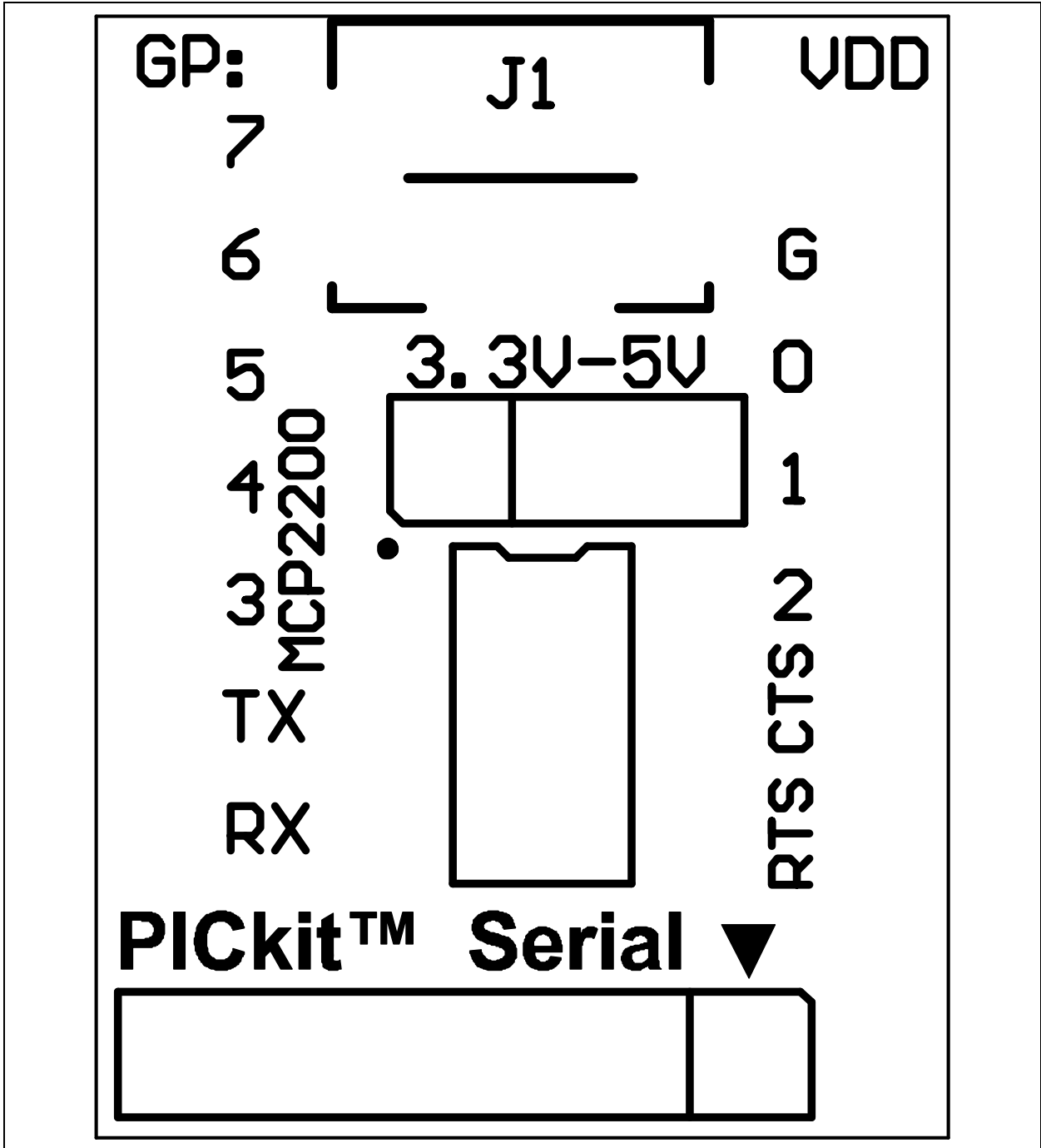

MCP2200 Breakout Module User's Guide

A.4 BOARD – TOP SILK AND PADS

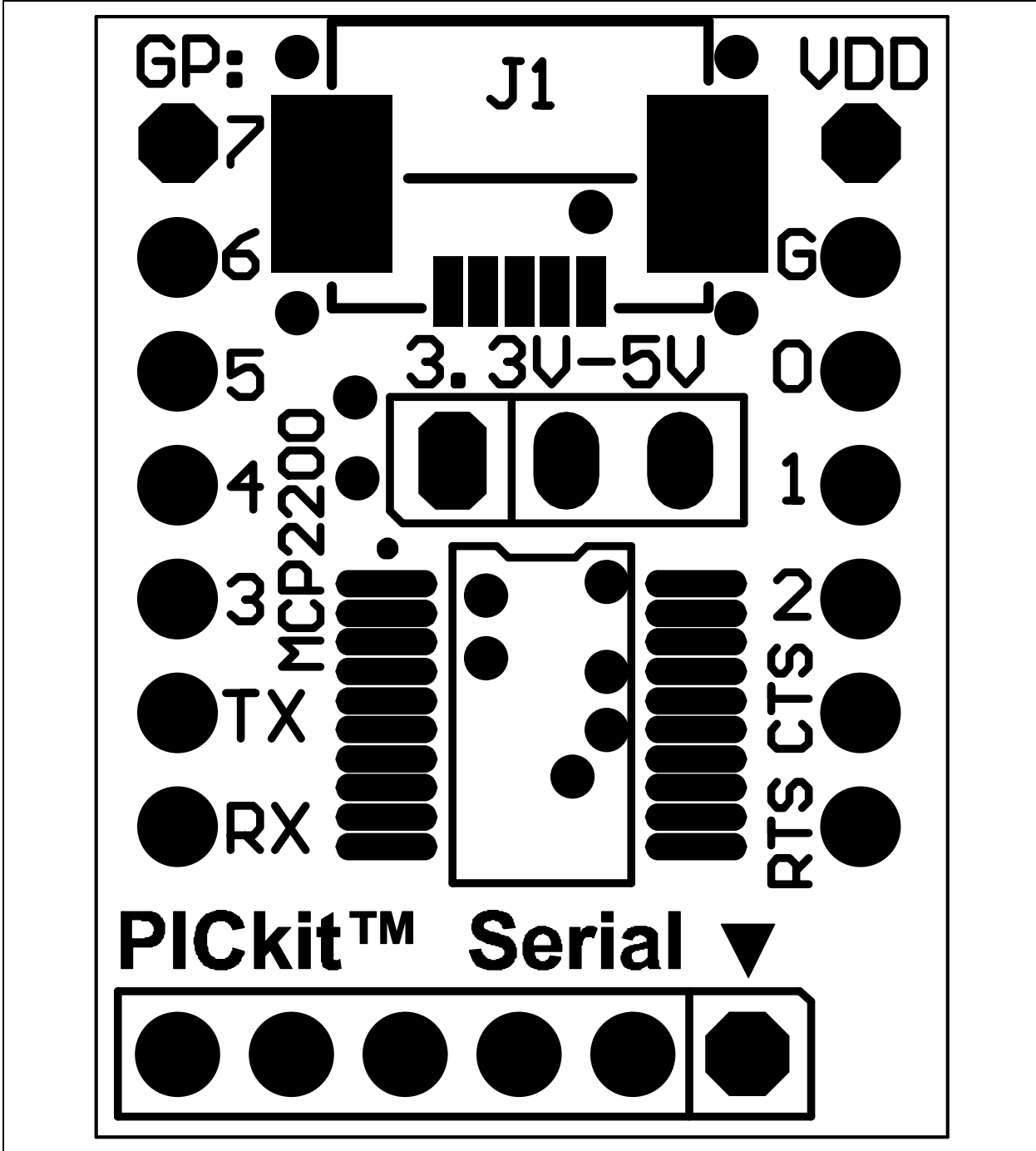

A.5 BOARD – TOP COPPER

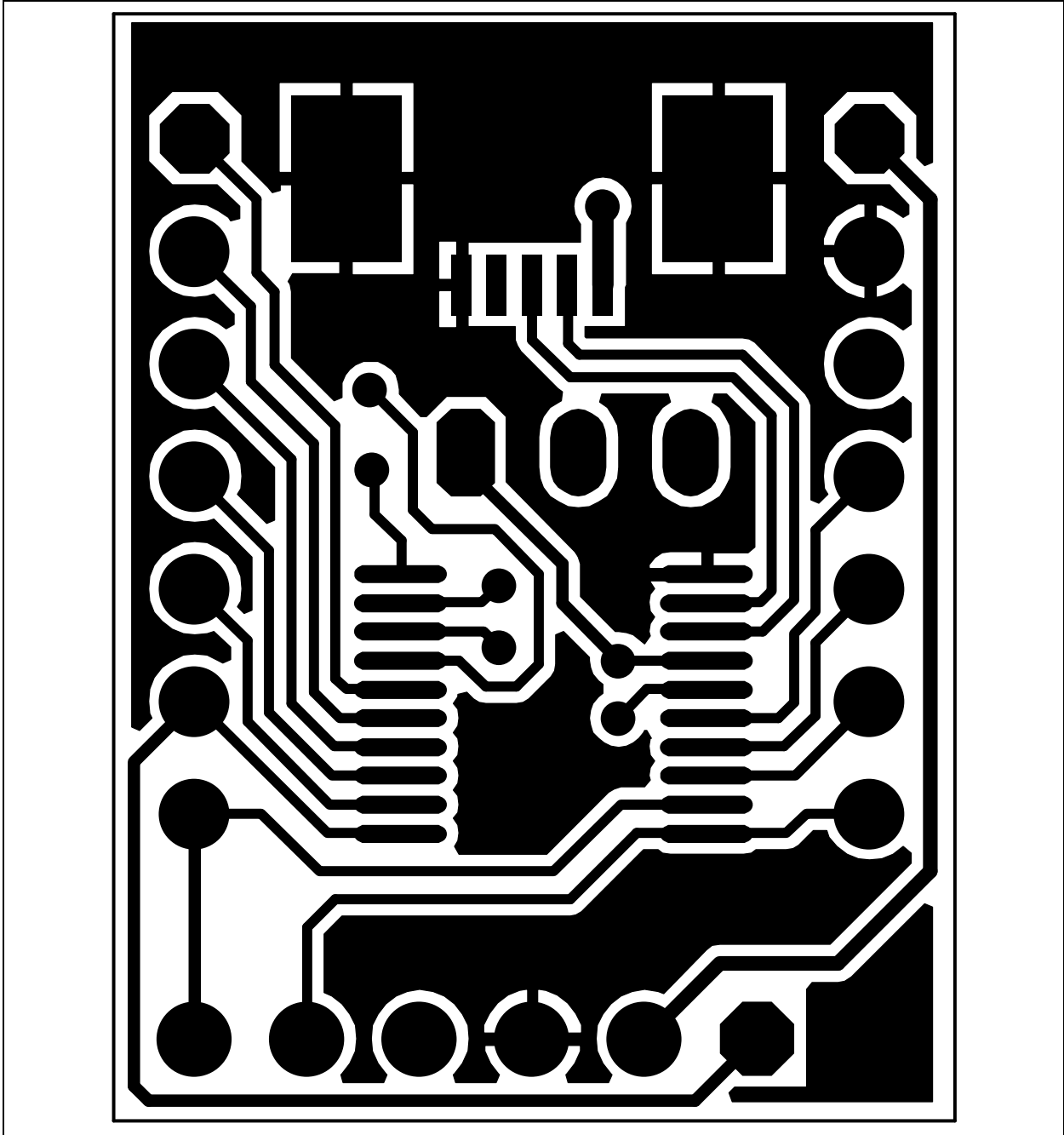

MCP2200 Breakout Module User's Guide

A.6 BOARD – BOTTOM SILK

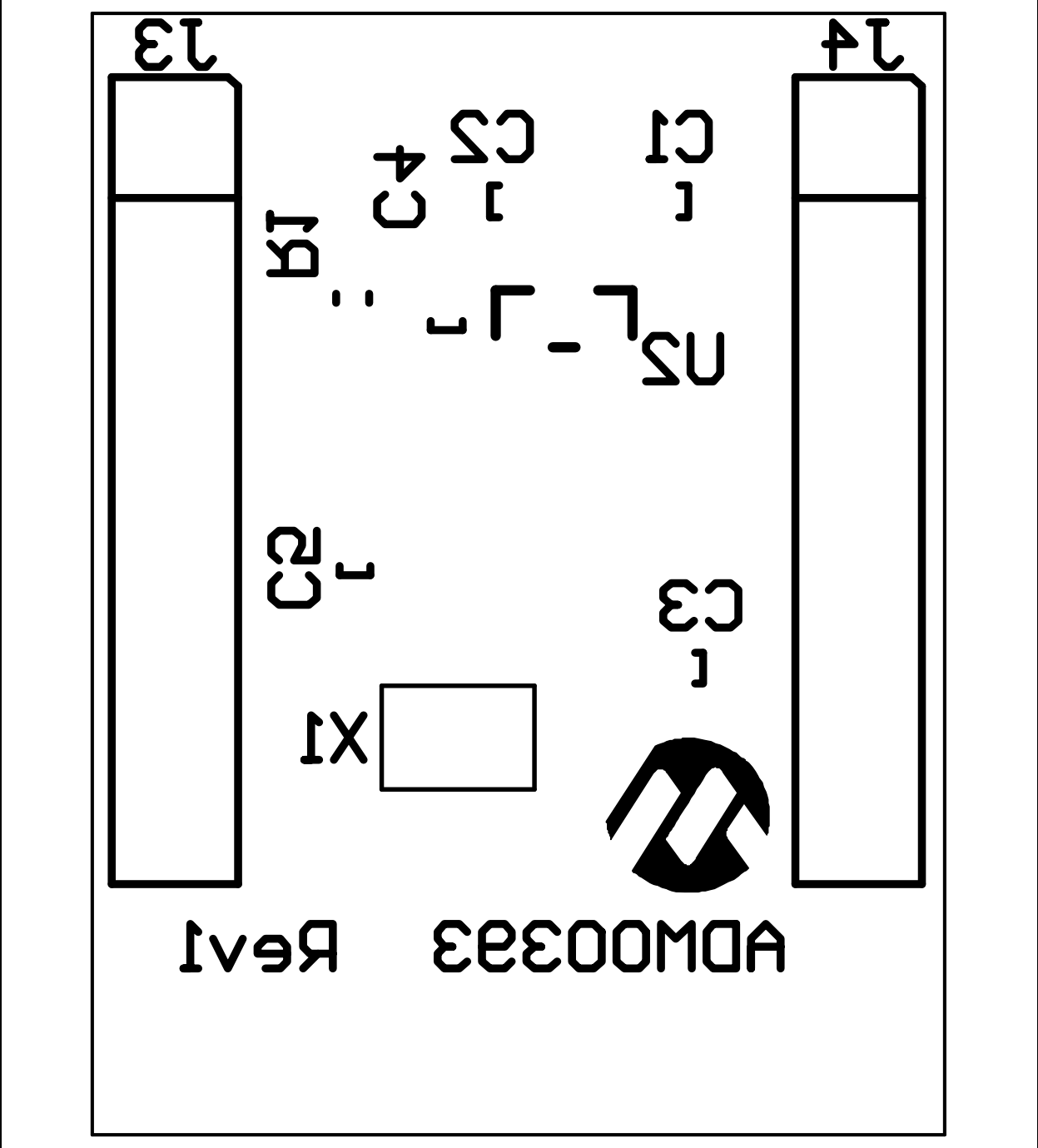

A.7 BOARD – BOTTOM SILK AND PADS

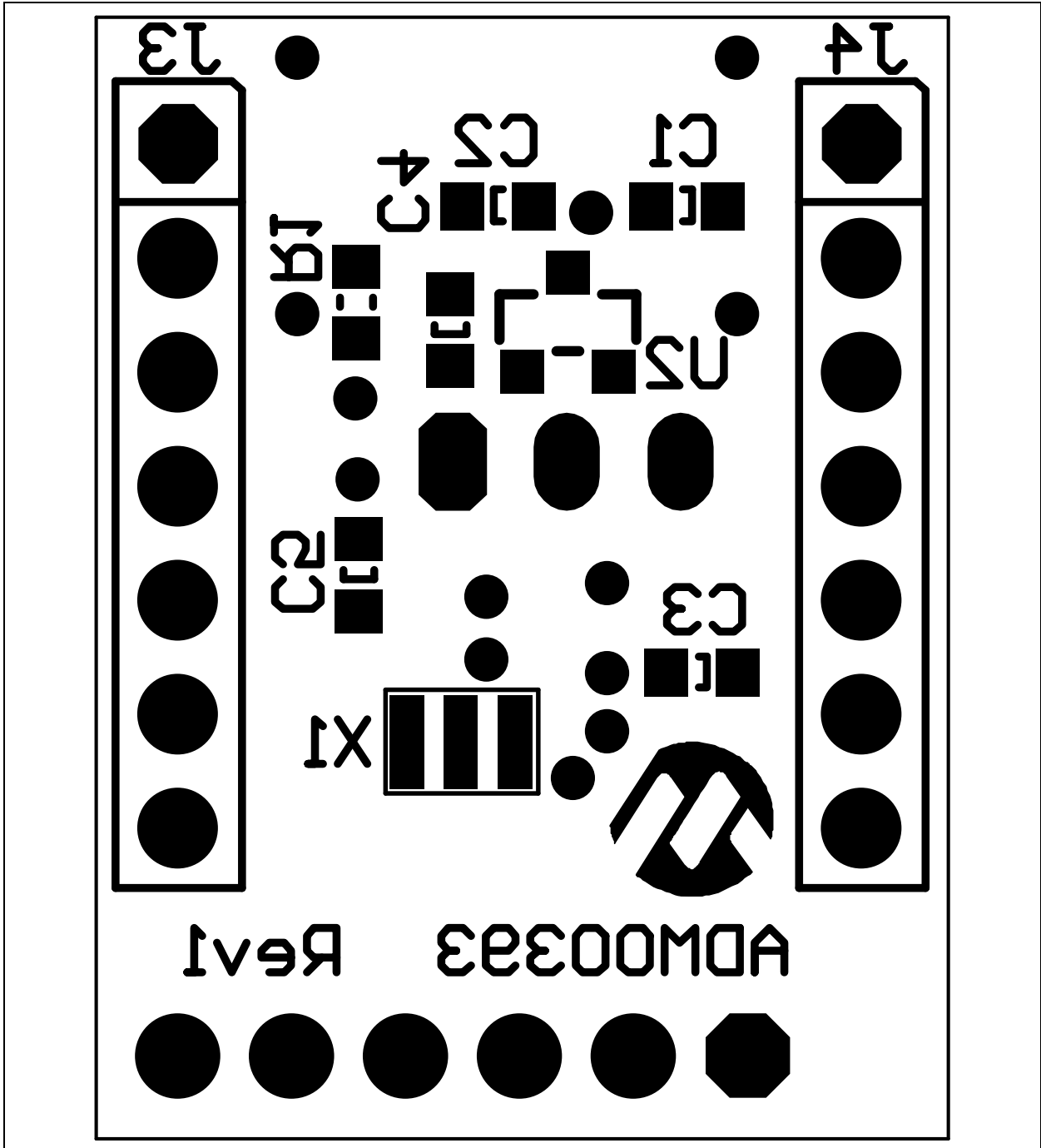

MCP2200 Breakout Module User's Guide

A.8 BOARD – BOTTOM COPPER

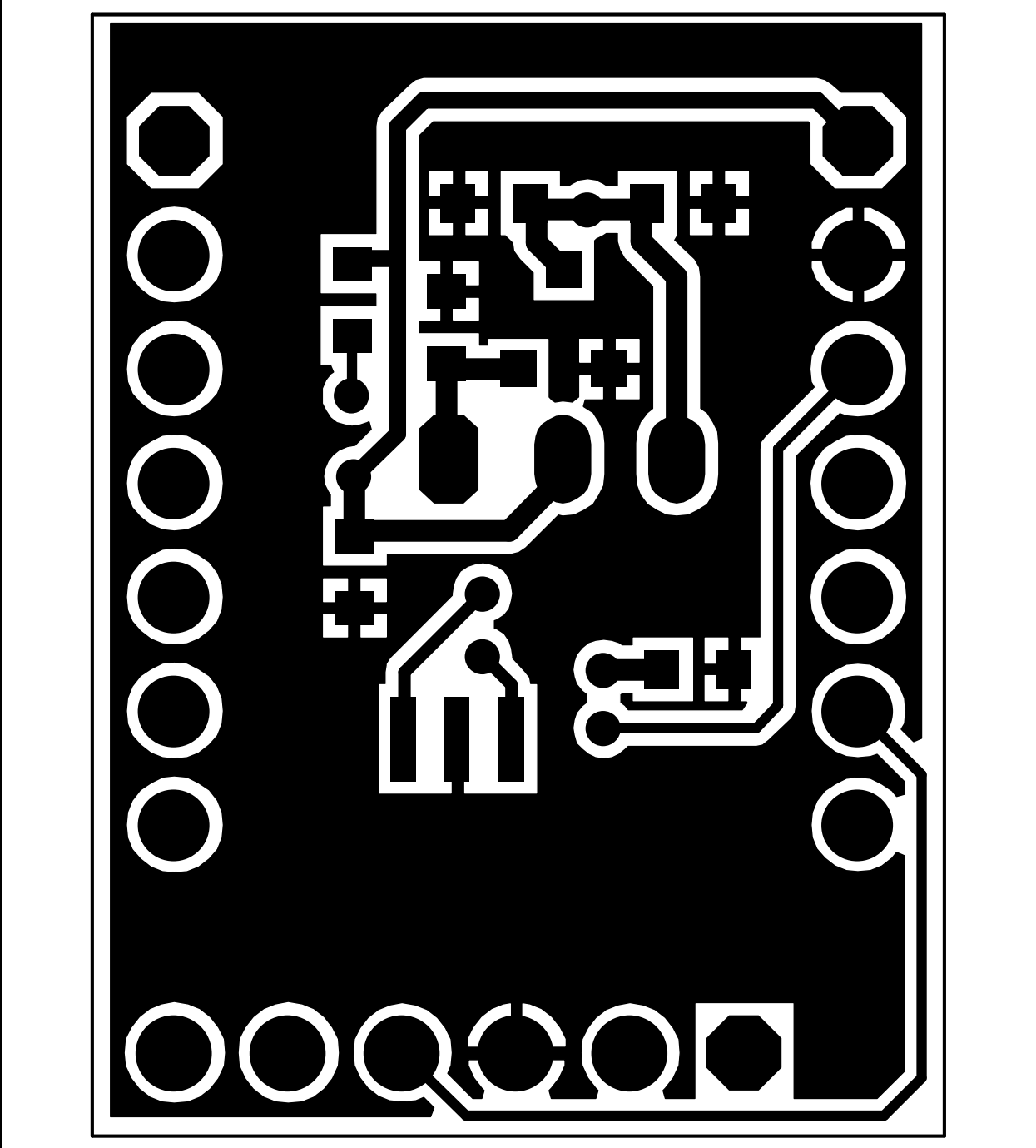

Appendix B. Bill of Materials (BOM)

TABLE B-1: BILL OF MATERIALS

Qty.	Designator	Description	Manufacturer	Part Number
1	C1	Cap. Ceramic 4.7uF 6.3V 10% X5R 0603	TDK Corporation	C1608X5R0J475K
3	C2, C3, C4	Cap. Ceramic 1uF 10% 16V X7R 0603	AVX Corporation	0603YC104KAT2A
1	C5	Cap. Ceramic 0.1uF 16V 10% X7R 0603	TDK Corporation	C1608X7R1C104K
1	J1	Conn. Rcpt. USB Mini B R/A SMD	Hirose Electric Co., Ltd.	UX60SC-MB-5ST(80)
1	J2	Conn. Hdr. Male .100 1x3 POS Vert.	TE Connectivity	HDR M 1x3 Vertical
2	J3, J4	DO NOT POPULATE Conn. Hdr. Male .100 1x7 POS Vert.	TE Connectivity	HDR M 1x7 Vertical
1	J5	DO NOT POPULATE Conn. Hdr. Male .100 1x6 POS Vert.	TE Connectivity	HDR M 1x6 Vertical
1	JP1	Conn. Jumper with Handle 2 POS .100" 30 GOLD	TE Connectivity	881545-2
1	PCB	MCP2200 Breakout Module Printed Circuit Board	—	104-00393
1	R1	Res. 4.7k Ohm 1/10W 5% 0603 SMD	Panasonic® - ECG	ERJ-3GGEYJ472V
1	U1	IC USB-to-UART SSOP-20	Microchip Technology Inc.	MCP2200-I/SS
1	U2	IC Reg. LDO 3.3V 250 mA SOT-23-3	Microchip Technology Inc.	MCP1700T-3302E/TT
1	X1	Ceramic Resonator 12.0 MHz SMD	Murata Electronics®	CSTCE12M0G55-R0

Note 1: The components listed in this Bill of Materials are representative of the PCB assembly. The released BOM used in manufacturing uses all RoHS-compliant components.



MICROCHIP

Worldwide Sales and Service

AMERICAS

Corporate Office
2355 West Chandler Blvd.
Chandler, AZ 85224-6199
Tel: 480-792-7200
Fax: 480-792-7277
Technical Support:
<http://www.microchip.com/support>
Web Address:
www.microchip.com

Atlanta
Duluth, GA
Tel: 678-957-9614
Fax: 678-957-1455

Boston
Westborough, MA
Tel: 774-760-0087
Fax: 774-760-0088

Chicago
Itasca, IL
Tel: 630-285-0071
Fax: 630-285-0075

Cleveland
Independence, OH
Tel: 216-447-0464
Fax: 216-447-0643

Dallas
Addison, TX
Tel: 972-818-7423
Fax: 972-818-2924

Detroit
Farmington Hills, MI
Tel: 248-538-2250
Fax: 248-538-2260

Indianapolis
Noblesville, IN
Tel: 317-773-8323
Fax: 317-773-5453

Los Angeles
Mission Viejo, CA
Tel: 949-462-9523
Fax: 949-462-9608

Santa Clara
Santa Clara, CA
Tel: 408-961-6444
Fax: 408-961-6445

Toronto
Mississauga, Ontario,
Canada
Tel: 905-673-0699
Fax: 905-673-6509

ASIA/PACIFIC

Asia Pacific Office
Suites 3707-14, 37th Floor
Tower 6, The Gateway
Harbour City, Kowloon
Hong Kong
Tel: 852-2401-1200
Fax: 852-2401-3431

Australia - Sydney
Tel: 61-2-9868-6733
Fax: 61-2-9868-6755

China - Beijing
Tel: 86-10-8569-7000
Fax: 86-10-8528-2104

China - Chengdu
Tel: 86-28-8665-5511
Fax: 86-28-8665-7889

China - Chongqing
Tel: 86-23-8980-9588
Fax: 86-23-8980-9500

China - Hangzhou
Tel: 86-571-2819-3187
Fax: 86-571-2819-3189

China - Hong Kong SAR
Tel: 852-2401-1200
Fax: 852-2401-3431

China - Nanjing
Tel: 86-25-8473-2460
Fax: 86-25-8473-2470

China - Qingdao
Tel: 86-532-8502-7355
Fax: 86-532-8502-7205

China - Shanghai
Tel: 86-21-5407-5533
Fax: 86-21-5407-5066

China - Shenyang
Tel: 86-24-2334-2829
Fax: 86-24-2334-2393

China - Shenzhen
Tel: 86-755-8203-2660
Fax: 86-755-8203-1760

China - Wuhan
Tel: 86-27-5980-5300
Fax: 86-27-5980-5118

China - Xian
Tel: 86-29-8833-7252
Fax: 86-29-8833-7256

China - Xiamen
Tel: 86-592-2388138
Fax: 86-592-2388130

China - Zhuhai
Tel: 86-756-3210040
Fax: 86-756-3210049

ASIA/PACIFIC

India - Bangalore
Tel: 91-80-3090-4444
Fax: 91-80-3090-4123

India - New Delhi
Tel: 91-11-4160-8631
Fax: 91-11-4160-8632

India - Pune
Tel: 91-20-2566-1512
Fax: 91-20-2566-1513

Japan - Osaka
Tel: 81-66-152-7160
Fax: 81-66-152-9310

Japan - Yokohama
Tel: 81-45-471-6166
Fax: 81-45-471-6122

Korea - Daegu
Tel: 82-53-744-4301
Fax: 82-53-744-4302

Korea - Seoul
Tel: 82-2-554-7200
Fax: 82-2-558-5932 or
82-2-558-5934

Malaysia - Kuala Lumpur
Tel: 60-3-6201-9857
Fax: 60-3-6201-9859

Malaysia - Penang
Tel: 60-4-227-8870
Fax: 60-4-227-4068

Philippines - Manila
Tel: 63-2-634-9065
Fax: 63-2-634-9069

Singapore
Tel: 65-6334-8870
Fax: 65-6334-8850

Taiwan - Hsin Chu
Tel: 886-3-5778-366
Fax: 886-3-5770-955

Taiwan - Kaohsiung
Tel: 886-7-536-4818
Fax: 886-7-330-9305

Taiwan - Taipei
Tel: 886-2-2500-6610
Fax: 886-2-2508-0102

Thailand - Bangkok
Tel: 66-2-694-1351
Fax: 66-2-694-1350

EUROPE

Austria - Wels
Tel: 43-7242-2244-39
Fax: 43-7242-2244-393

Denmark - Copenhagen
Tel: 45-4450-2828
Fax: 45-4485-2829

France - Paris
Tel: 33-1-69-53-63-20
Fax: 33-1-69-30-90-79

Germany - Munich
Tel: 49-89-627-144-0
Fax: 49-89-627-144-44

Italy - Milan
Tel: 39-0331-742611
Fax: 39-0331-466781

Netherlands - Drunen
Tel: 31-416-690399
Fax: 31-416-690340

Spain - Madrid
Tel: 34-91-708-08-90
Fax: 34-91-708-08-91

UK - Wokingham
Tel: 44-118-921-5869
Fax: 44-118-921-5820

11/29/11