



TAOGLAS®



Datasheet

Part No:
CGGP.35.2.A.08

Description:
35mm with 2mm Low-Profile
GPS/GLONASS/Galileo Dual-Band Ceramic Patch Antenna

Features:
4.27dBi Peak Gain for GPS/Galileo Band
4.63dBi Peak Gain for GLONASS Band
Low Profile – 2mm Height
Pin Type Ceramic Patch Antenna
Manufactured in an IATF16949 Approved Facility Dims: 35*35*2mm
RoHS & REACH Compliant

1. Introduction	3
2. Specifications	4
3. Antenna Characteristics	5
4. Antenna Radiation Pattern	7
5. Mechanical Drawing	10
6. PCB Footprint Recommendation	11
7. Antenna Integration Guide	12
8. Evaluation Board Mechanical Drawing	17
9. Packaging	18
<hr/>	
Changelog	19

Taoglas makes no warranties based on the accuracy or completeness of the contents of this document and reserves the right to make changes to specifications and product descriptions at any time without notice. Taoglas reserves all rights to this document and the information contained herein. Reproduction, use or disclosure to third parties without express permission is strictly prohibited.



1. Introduction



The CGGP.35.2.A.08 is a low profile ceramic GPS/GLONASS/Galileo passive patch antenna with a thickness of 2mm. It was designed for vehicle navigation applications as well as other M2M/IoT devices. Typical applicable industries are transportation, defense, marine, agriculture and navigation.

The antenna has been tuned on a 70*70mm ground plane, working at 1575.42MHz and 1602MHz, with 4.27dBi gain and 4.63dBi gain, respectively. The low profile design makes this antenna perfect for applications where space is limited. It can be easily through-hole mounted on PCB via pin. Double sided adhesive on the bottom of the patch helps to keep it in place while undergoing mounting. The CGGP.35.2.A.08 is manufactured and tested in a TS16949 first tier automotive approved facility.

For large volume GPS/GLONASS/Galileo projects where performance is paramount, tuning for customer specific device environments and ground-plane sizes is needed, so custom tuned patch antennas should always be used. Taoglas can also provide different pin lengths for these antennas, subject to potential NRE and MOQ. For more details please contact your regional Taoglas customer support team.

2. Specifications

Electrical		
Application Bands	GPS/GALILEO	GLONASS
Operation Frequency	1575.42 ±1.023MHz	1602 ±5MHz
Return Loss	-10dB max.	
Peak Gain	4.27dBi	4.63dBi
Efficiency	69.73%	71.98%
Impedance	50Ω	
Mechanical		
Ceramic Dimension	35*35*2mm	
Pin Diameter	0.85mm	
Pin Length	2.4mm	
Weight	3g	
Environmental		
Storage Temperature	-40°C to 85°C	
Operation Temperature	-40°C to 85°C	
Moisture Sensitivity	Level 3	

* Antenna properties were measured with the antenna mounted on 70*70mm Ground Plane

3. Antenna Characteristics

3.1 Return Loss

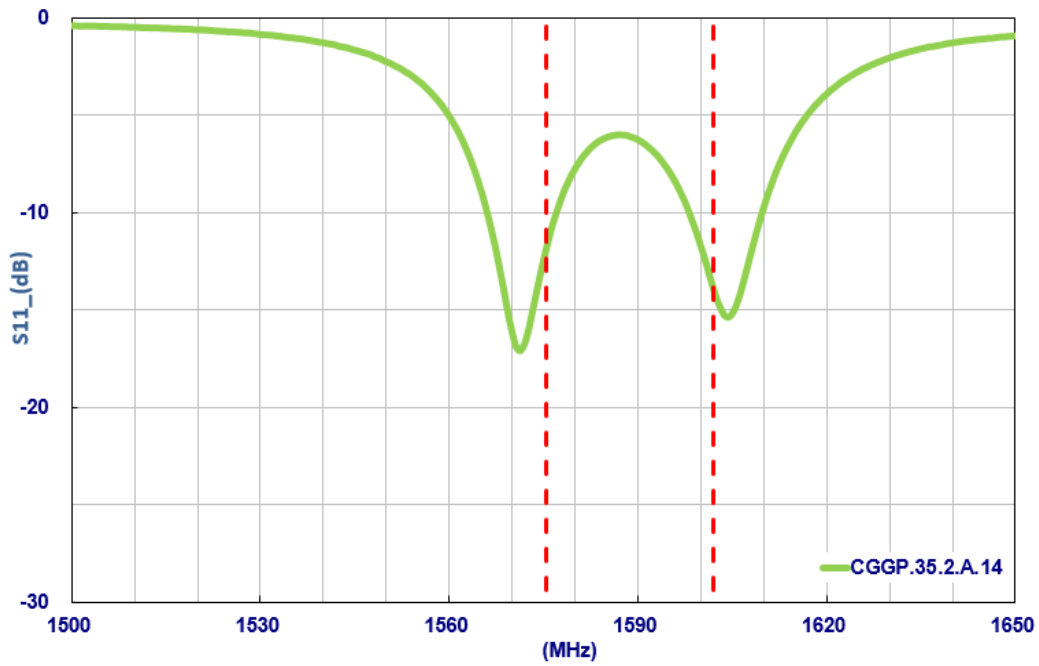

3.2 Efficiency

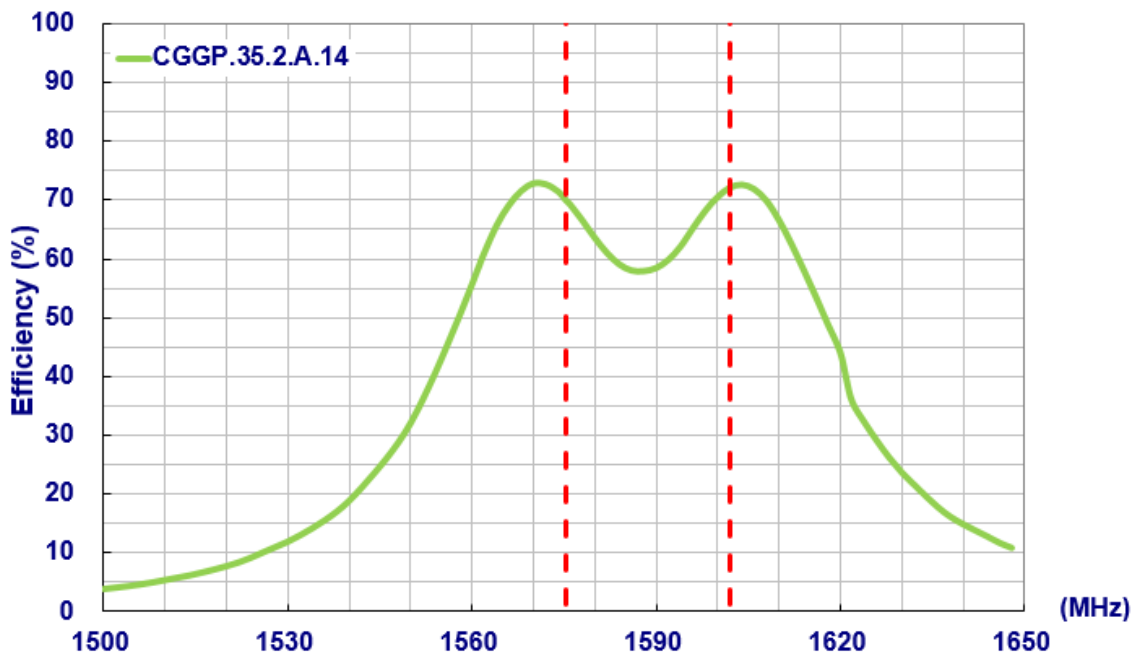

3.3 Average Gain

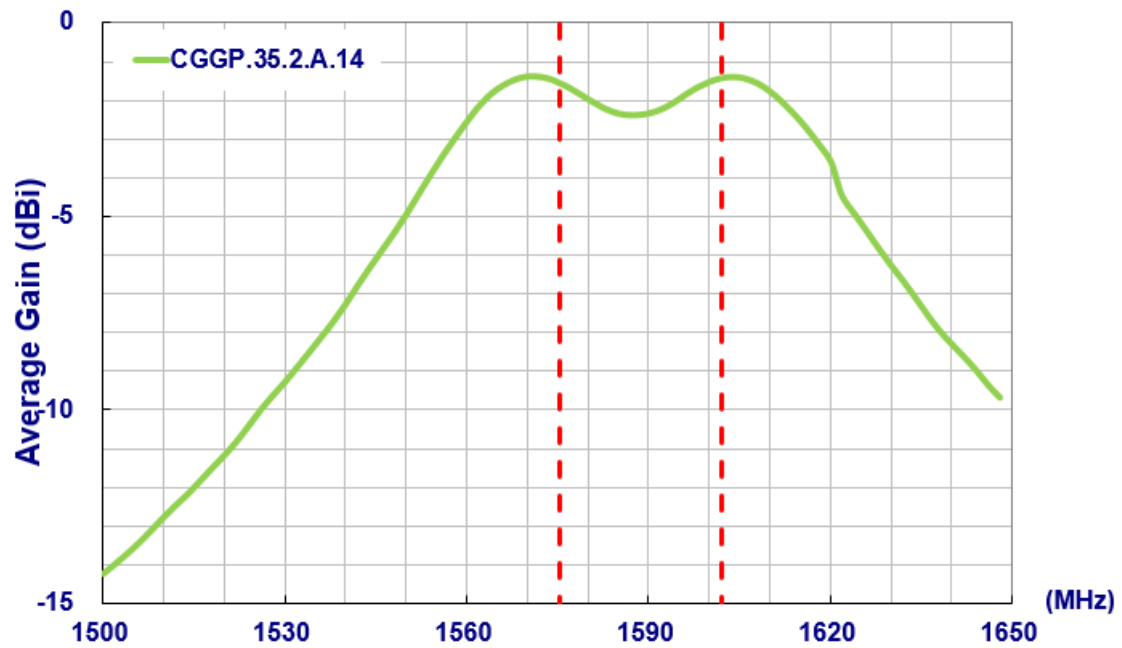

3.4 Peak Gain

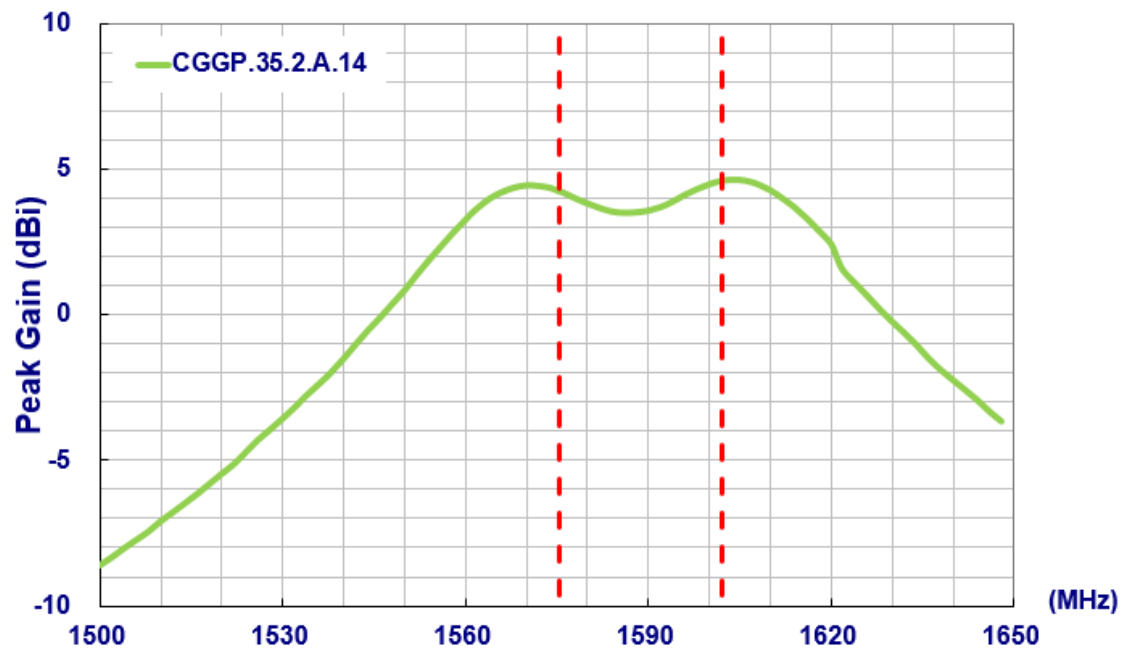

4. Antenna Radiation Pattern

4.1 Measurement Setup

The CGGP.35.2.A.08 antenna is tested with 70*70mm ground plane in a CTIA certified ETS-Lindgren Anechoic Chamber. The test setup is shown below.

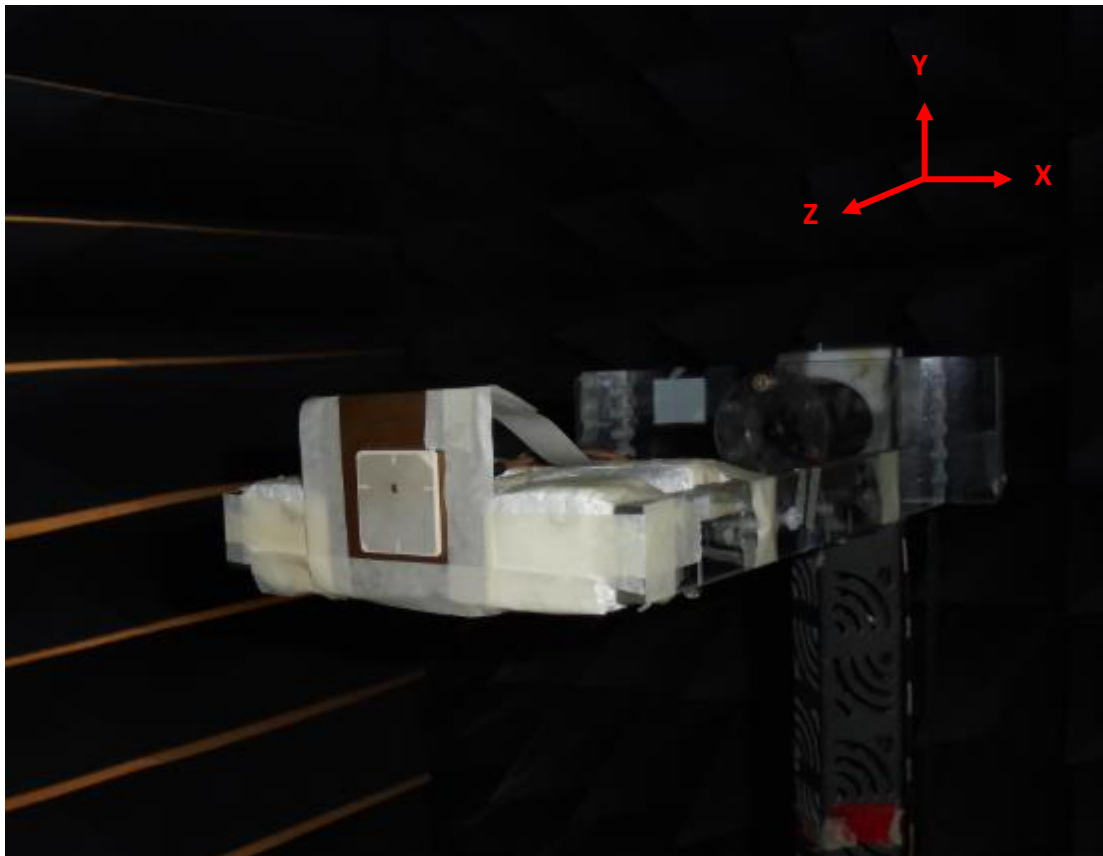

4.2 2D Radiation Pattern

XY Plane

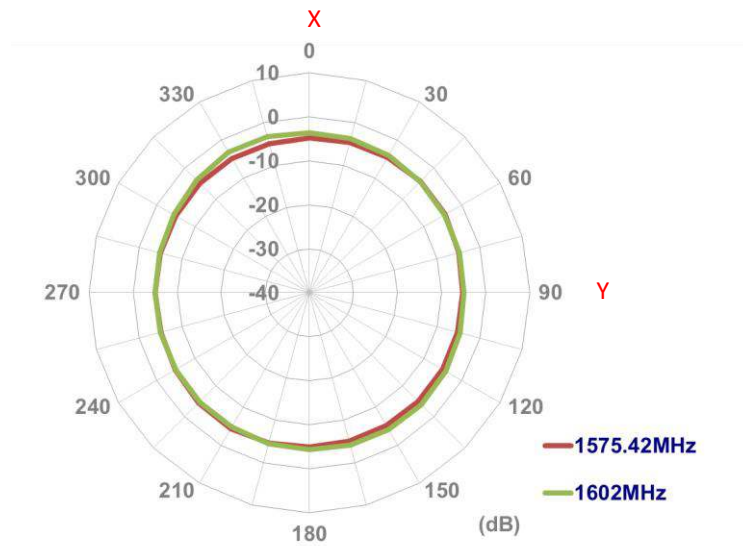

XZ Plane

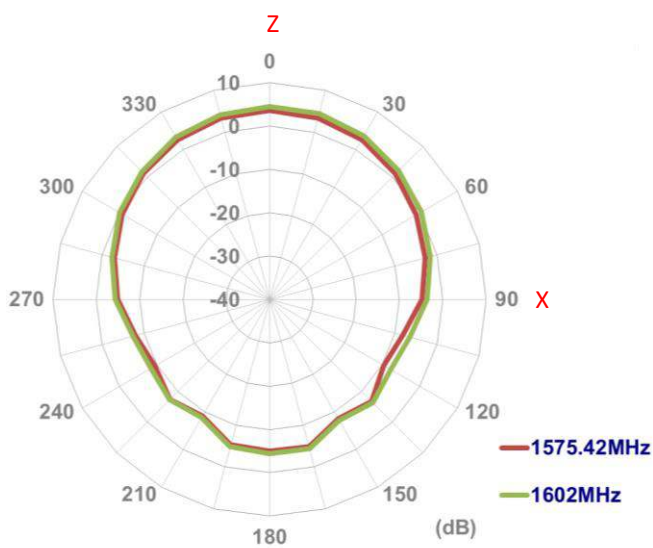

YZ Plane

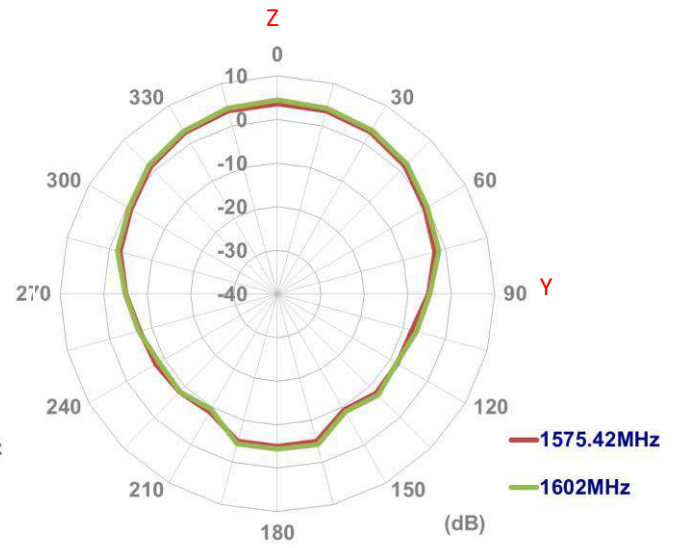

4.3 3D Radiation Pattern

1575.42MHz

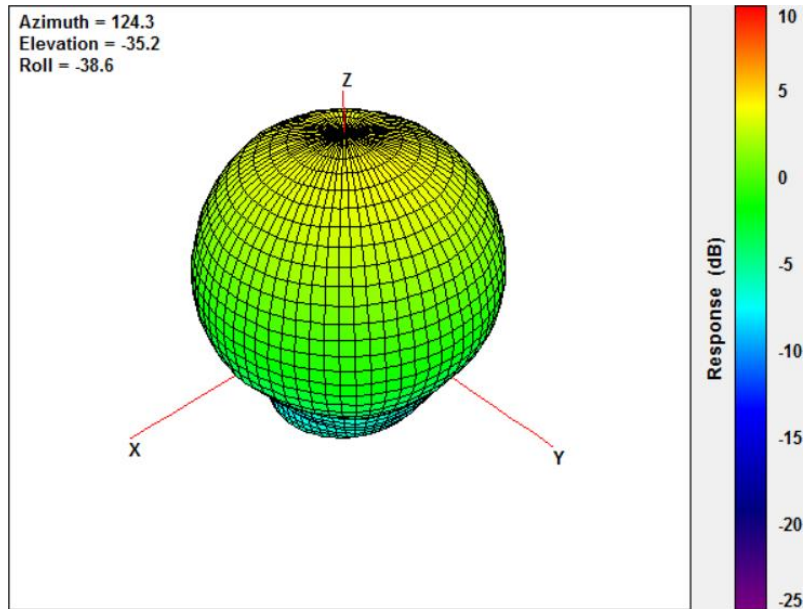

1602MHz

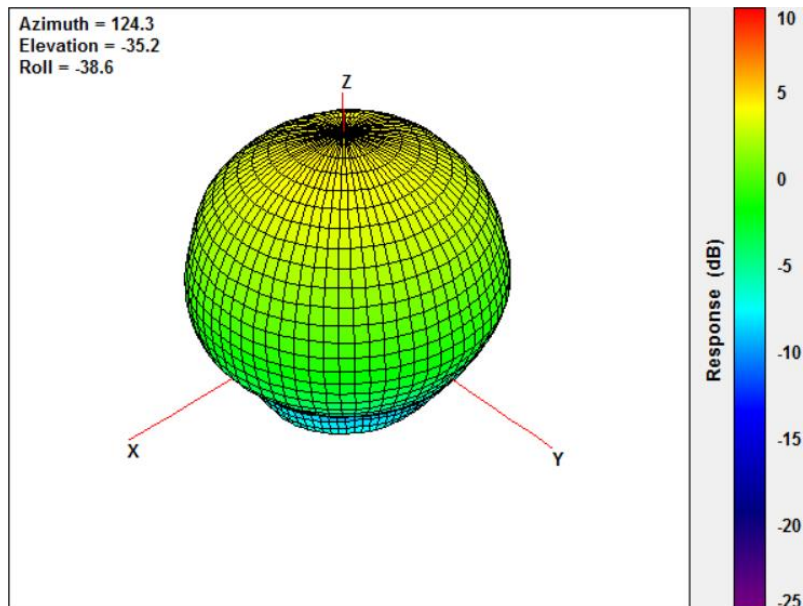

5. Mechanical Drawing (Unit: mm)

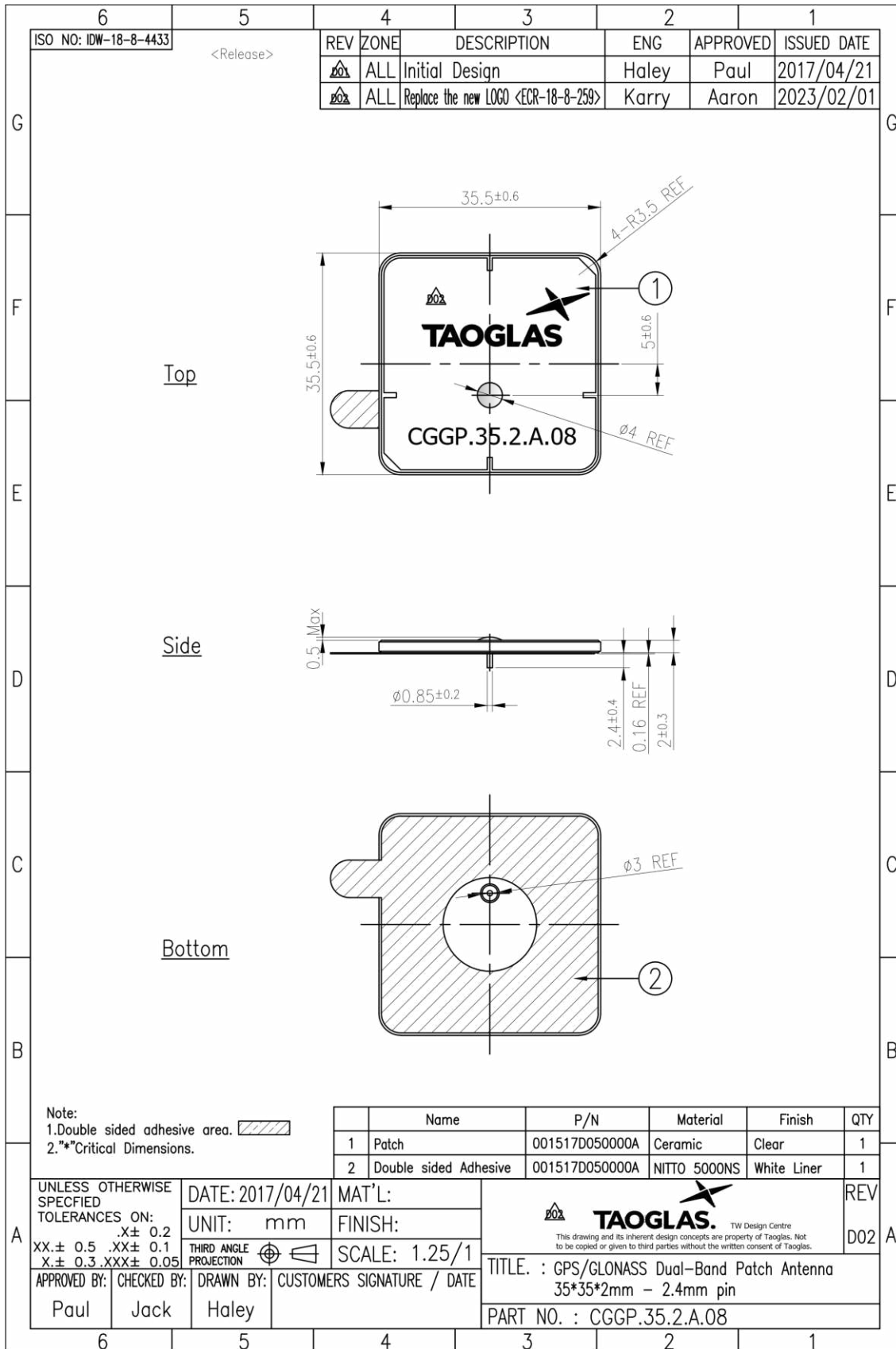

6. PCB Footprint Recommendation

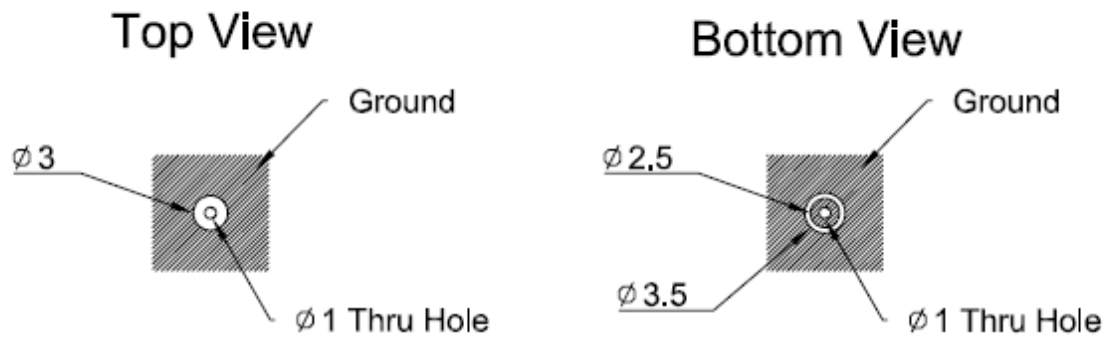

Tolerance: +/- 0,20
 Unit:mm

7. Antenna Integration Guide

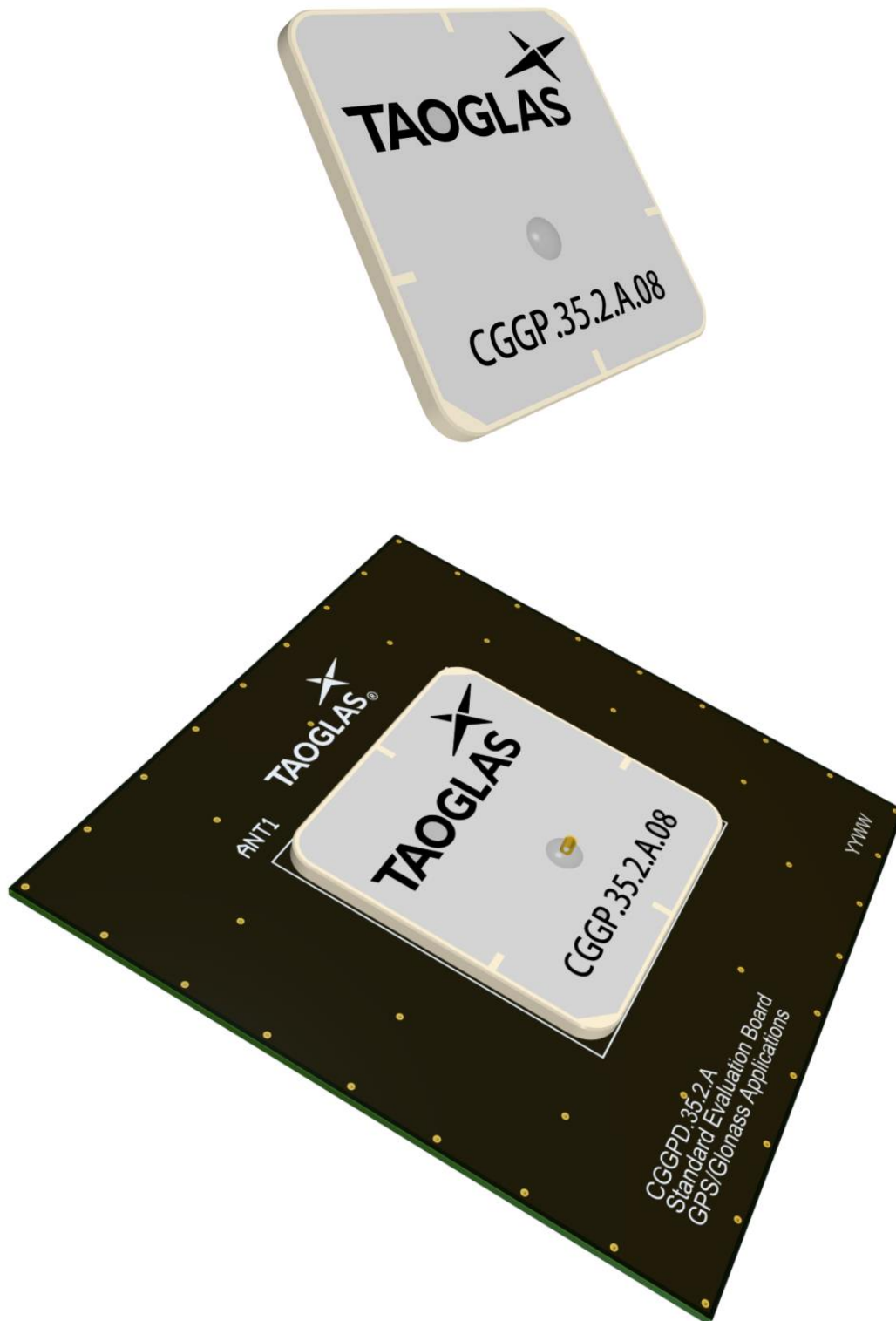

7.1 Schematic Symbol and Pin Definition

The circuit symbol for the antenna is shown below. The antenna has 1 pin as indicated below.

Pin	Description
1	RF Feed

CGGP.35.2.A.08
ANT1

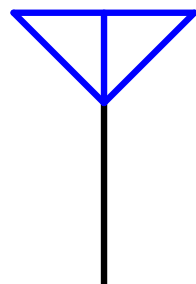

7.2 Antenna Integration

The antenna should be placed at the center of the ground plane with a length and width of 70mm. Maintaining a square symmetric ground plane shape and symmetric environment around the antenna is critical to maintaining the excellent axial ratio and phase center performance shown in this datasheet.



Top Side w/ Solder Mask

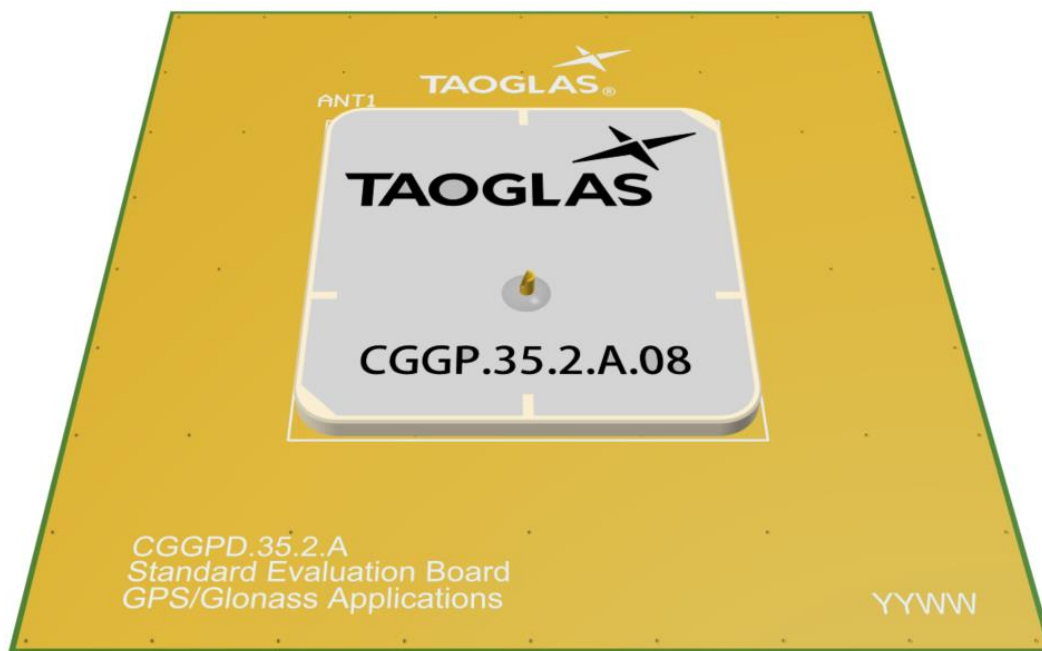

Top Side w/o Solder Mask

7.3 PCB Layout

The footprint and clearance on the PCB must comply with the antenna specification. The PCB layout shown in the diagram below demonstrates the antenna footprint.



Topside

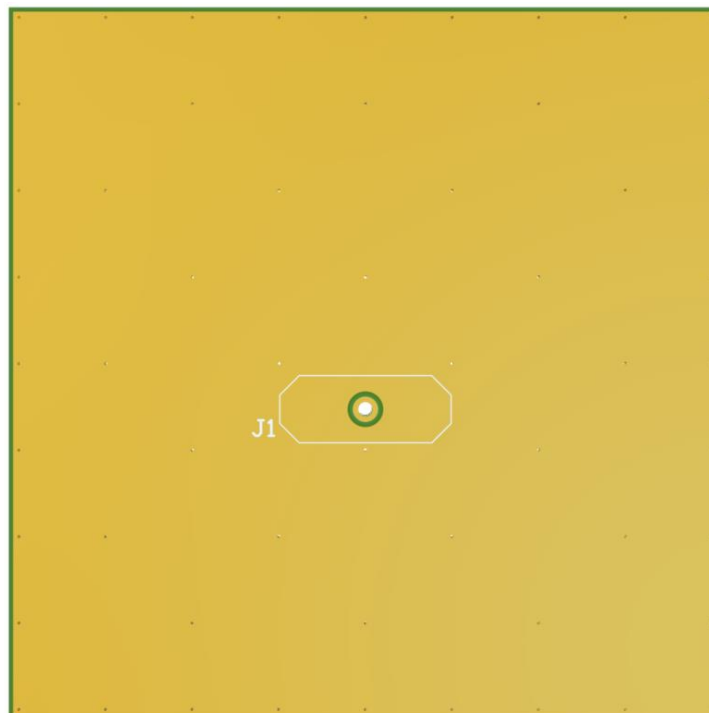

Bottom Side

7.4 Evaluation Board

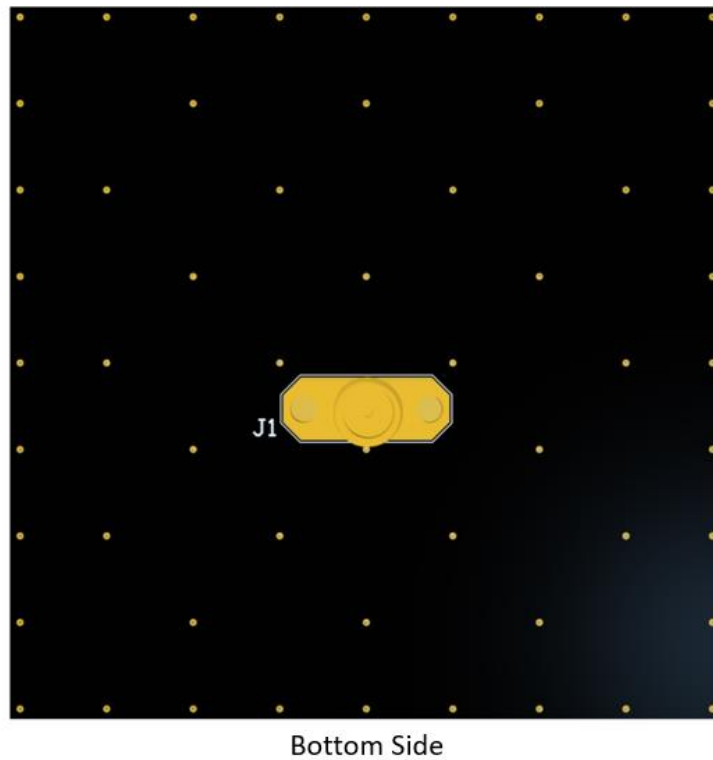
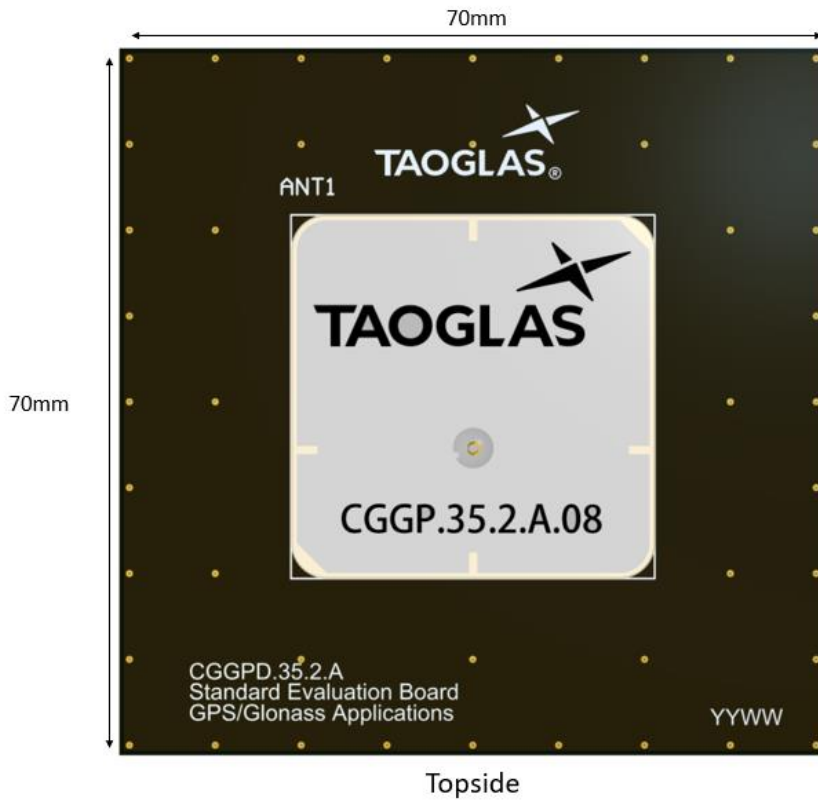

8. Evaluation Board Mechanical Drawing (Unit: mm)

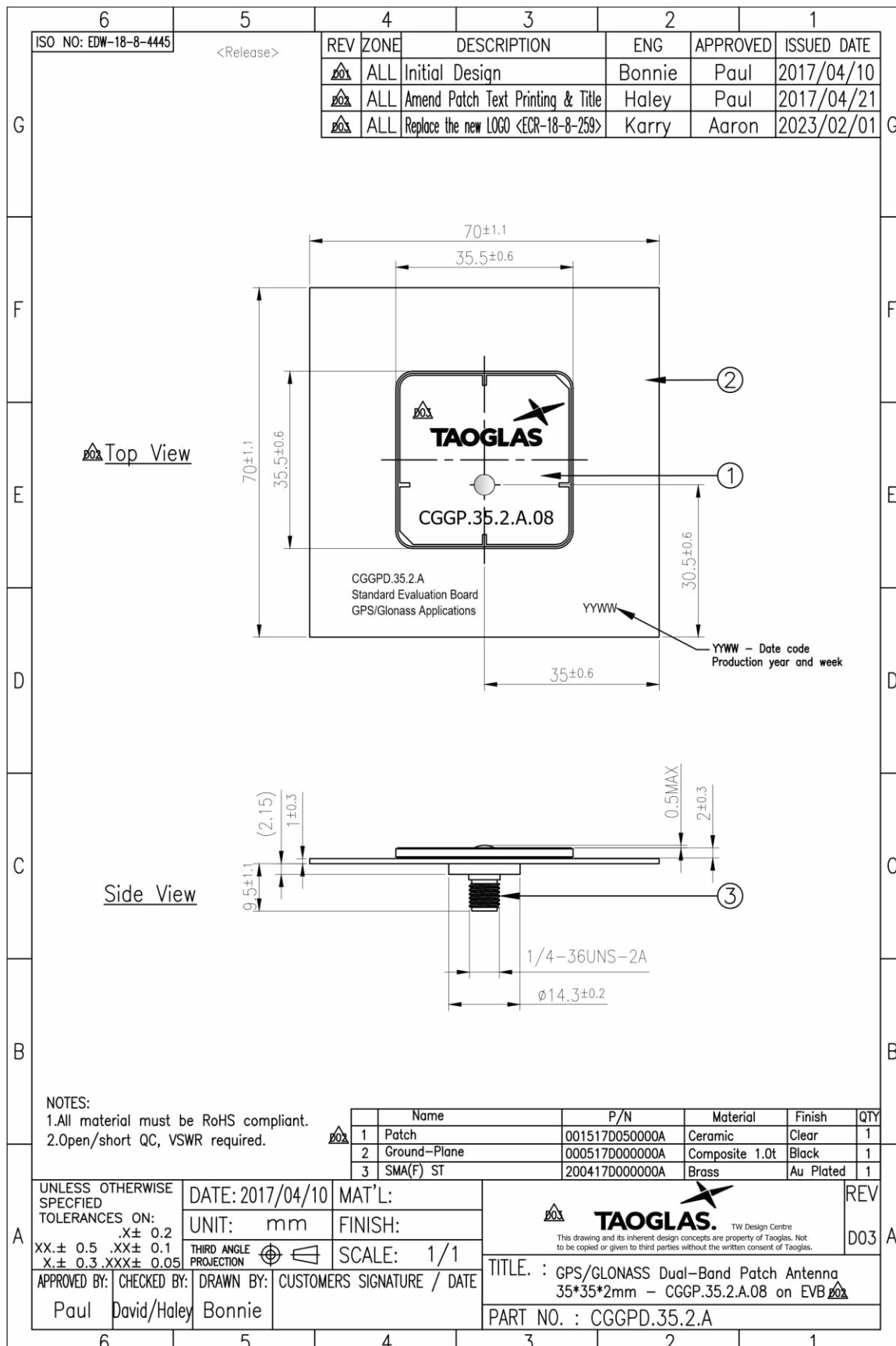

9. Packaging

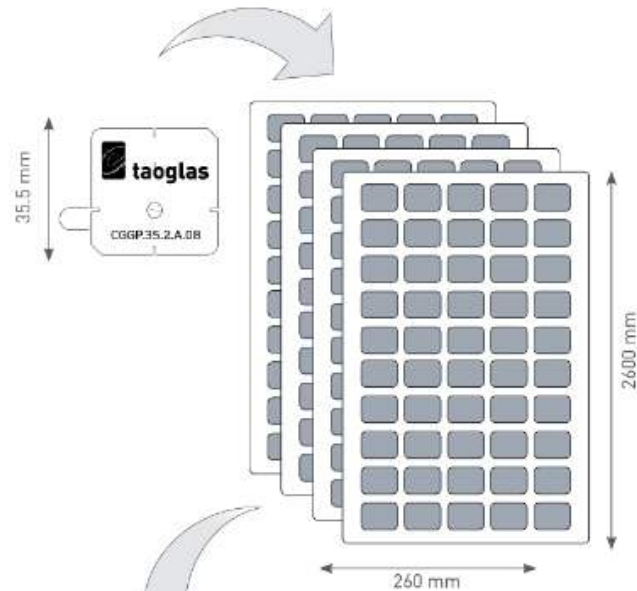

100 pcs CGGP.35.2.A.08 per tray
 Tray Dimensions - 260*260*80mm
 Weight - 94g

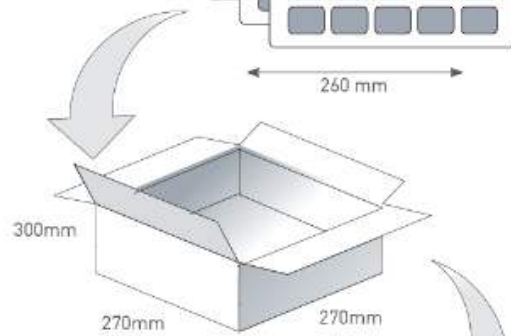

400 pcs CGGP.35.2.A.08 per Inner Carton
 Inner Carton Dimensions - 270*270*300mm
 Weight - 4.07kg

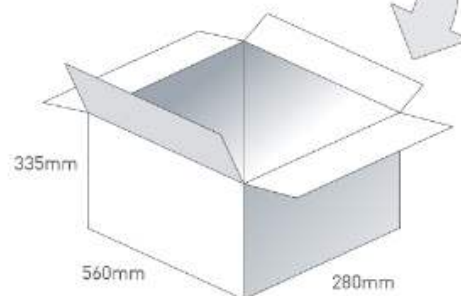

800 pcs CGGP.35.2.A.08 per Carton
 Carton Dimensions - 560*280*335mm
 Weight - 8.6kg

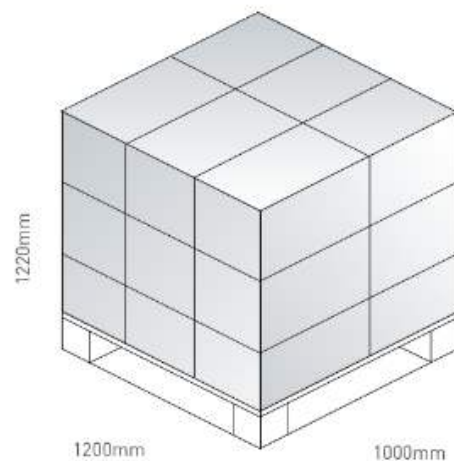

Pallet Dimensions 1200*1000*1220mm
 18 Cartons per Pallet
 6 Cartons per layer
 3 Layers

Changelog for the datasheet

SPE-16-8-074 – CGGP.35.2.A.08

Revision: E (Current Version)

Date:	2023-02-27
Changes:	Antenna Integration Guide Added
Changes Made by:	Cesar Sousa

Previous Revisions

Revision: D (Current Version)

Date:	2020-11-23
Changes:	Updated to new format Added Moisture Sensitivity Level 3 to Environmental Specifications
Changes Made by:	Dan Cantwell

Revision: C

Date:	2018-12-18
Changes:	Amended Automotive Rating
Changes Made by:	Jack Conroy

Revision: B

Date:	2018-09-11
Changes:	Amended Drawing
Changes Made by:	Jack Conroy

Revision: A (Original First Release)

Date:	2017-07-18
Notes:	
Author:	Technical Writer



TAOGLAS®

www.taoglas.com

