



The Future of Analog IC Technology®

EV26075EQ-00A

Single-Cell 1A High Efficiency Cradle Charger Evaluation Board

DESCRIPTION

The EV26075EQ-00A is an evaluation board for the MP26075, a linear, high performance, and high efficiency single cell Li-Ion or Li-polymer battery charger for AC adapter input in the plug-in, cradle charger applications.

For EV26075EQ-00A, the topology for AC-DC conversion is a flyback. HF0100 is the primacy side controller. MP26075 offers the feedback signal through a photo-coupler to control the flyback output voltage against the battery voltage to increases energy efficiency. For guaranteed safe operation, MP26075 controls power up sequencing. It ramps-up AC-Adapter firstly to limit inrush current when Adapter plug in.

The charging current of EV26075DQ-00A is set at 1A, which can be programmed by an external resistor (Rset).

ELECTRICAL SPECIFICATION

Parameter	Symbol	Value	Units
Input Voltage	AC IN	85~265	V
Charge Current	I _{CHG}	1	A

FEATURES

- Voltage control function for the fly-back controller
- High charge efficiency
- Low current pre-charge mode
- Controlled power-up sequencing
- Battery temperature monitoring
- Charge status indication
- Auto-Recharge
- Fault indications
- Internal timer
- Input/output OVP
- over temperature protection

APPLICATIONS

- Cell Phones
- MP3 Players
- Smart Phones
- PDAs
- Digital Cameras

"MPS" and "The Future of Analog IC Technology" are Registered Trademarks of Monolithic Power Systems, Inc.

EV26075EQ-00A EVALUATION BOARD

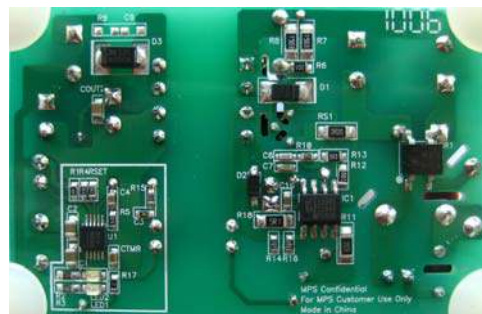

(L x W x H) 2.23" x 1.54" x 0.84"
(5.66cm x 3.91cm x 2.13cm)

Board Number	MPS IC Number
EV26075EQ-00A	MP26075EQ

Charge Curve

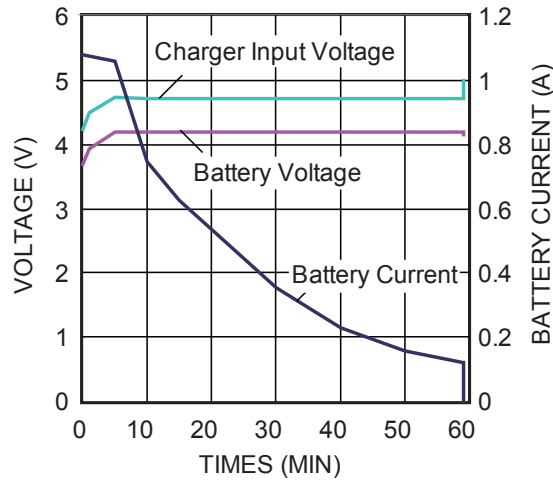

EVALUATION BOARD SCHEMATIC

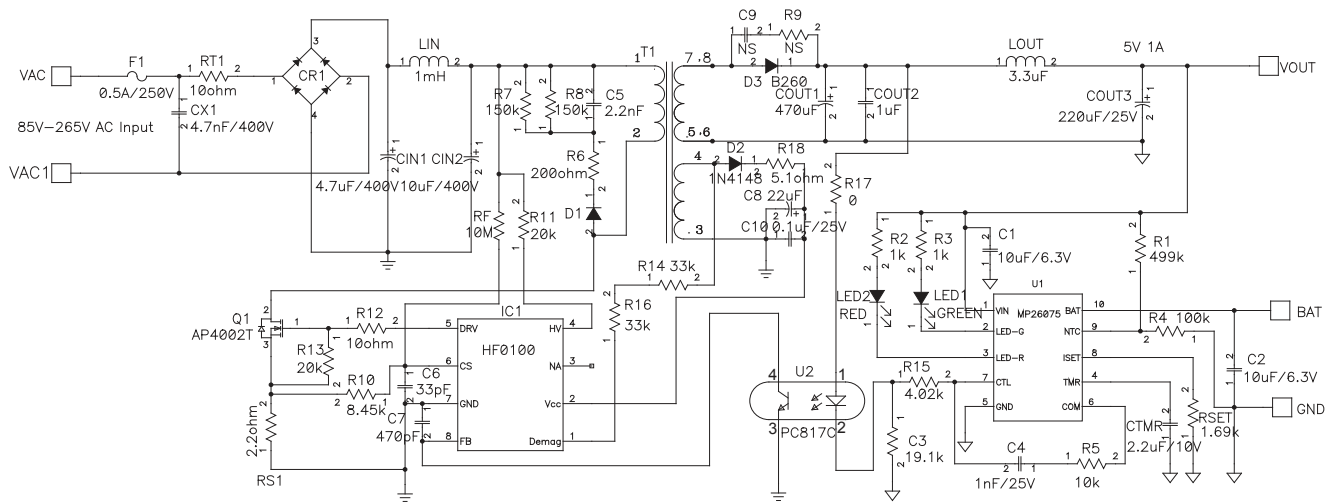

EV26075DQ-00A BILL OF MATERIALS

Qty	Ref	Value	Description	Package	Manufacturer	Manufacturer P/N
2	C1, C2	10 μ F	Ceramic Cap ,6.3V, X5R	0805	KYOCERA	CM21X5R106K06AT
1	C4	1nF	Ceramic Cap ,50V, X7R	0603	Murata	GRM188R71H102KA01D
1	C5	2.2nF	250V Film capacitor	DIP	Murata	DE1E3KX222MA4BL01
1	C6	33pF	Ceramic Cap, 50V, C0G	0603	Murata	GRM1885C1H330JA01
1	C7	470pF	Ceramic Cap ,50V, X7R	0603	Murata	GRM188R71H471KA01D
1	C8	22 μ F	Electrolytic Cap ,22 μ F,50V	DIP	Jianghai(江海)	CD281L-50V22
1	C9	NS				
1	C10	0.1 μ F	Ceramic Cap, 50V, X7R	0603	Murata	GRM188R71H104KA93D
1	CIN1	4.7 μ F	4.7 μ F 400V	DIP	Jianghai(江海)	CD263-400V4.7
1	CIN2	10 μ F	10 μ F 400V	DIP	Jianghai(江海)	CD110-400V10
1	COUT1	470 μ F	Electrolytic Cap ,470 μ F,6.3V	DIP	Jianghai(江海)	CD287-6.3V470
1	COUT2	1 μ F	Ceramic Cap, 6.3V, X5R	0805	Murata	GRM188R60J105KA0
1	COUT3	220 μ F	Electrolytic Cap ,220 μ F,10V	DIP	Jianghai(江海)	CD110-10V220
1	CR1	RH06	Rectifier 0.5A. 600V peak reverse voltage	Minidip	DIODES	RH06
1	CTMR	2.2 μ F	Ceramic Cap ,10V, X7R	0603	Murata	GRM188R71A225KE1
1	CX1	4.7nF	Film capacitor	DIP	Vishay	BFC33820472
1	C3	19.1k	Film Res., 1%	0603	Yageo	RC0603FR-0719K1L
1	R1	499k	Film Res., 1%	0603	Yageo	RC0603FR-07499KL
2	R2, R3	1k	Film Res., 5%	0805	Yageo	RC0805JR-071KL
1	R4	100k	Film Res., 1%	0603	Yageo	RC0603FR-07100KL
1	R5	10k	Film Res., 1%	0603	Yageo	RC0603FR-0710KL
1	R6	200 Ω	Film Res., 5%	0805	Any	
2	R7,R8	150k	Film Res., 1%	1206	Panasonic	ERJ8ENF1503V
1	R9	NS				
1	R10	8.45k	Film Res., 1%	0603	Yageo	RC0603FR-078K45L
1	R11	20k	Film Res., 5%	1206	LIZ	CR1206J40203G
1	R12	10 Ω	Film Res., 5%	0805	LIZ	CR05T05NJ10R
1	R13	20k	Film Res., 5%	0805	Yageo	RC0805JR-0720KL
2	R14,R16	33k	Film Res., 1%	0603	Yageo	RC0603FR-0733RL
1	R15	4.02k	Film Res., 1%	0603	Yageo	RC0603FR-074K02L
1	R17	0	Film Res., 5%	0603	Any	
1	R18	5.1 Ω	Film Res., 5%	1206	Yageo	RC1206JR-075R1

EV26075DQ-00A BILL OF MATERIALS (continued)

Qty	Ref	Value	Description	Package	Manufacturer	Manufacturer P/N
1	RF	10M	Film Res., 1%	DIP	Any	
1	RS1	2.2Ω	Film Res., 1%	1206	Any	
1	RSET	1.69k	Film Res., 1%	0603	Yageo	RC0603FR-071K69L
1	RT1	10Ω	Res., 15%	DIP	Murata	NTPAA100LDNBO
1	D1	RS1J	600V,1A	SMA	DIODES	RS1J
1	D2	1N4148	0.15A,75V	SOD-123	DIODES	1N4148
1	D3	B260A	2A,60V	SMA	DIODES	B260A
1	F1	0.5A	SS-5-500mA, 0.5A fuse,250VAC	DIP	COOPER BUSSMANN	SS-5-500mA
1	LED1	LED GREEN	LED GREEN	0805	BRTLED	BL-HGB35A-TRB
1	LED2	LED RED	LED RED	0805	BRTLED	BL-HUF35A-TRB
1	LIN	1mH	Filter inductor. 1000μH,max current:0.16A, 2.96Ω DCR	DIP	TOKO	8RHB2#822LY-102K
1	LOUT	3.3μH	Filter inductor.3.3uH, max dc current:2.66A, 0.025Ω DCR	DIP	TOKO	8RHB2#822LY- 3R3M
1	Q1	AP4002T	600V,0.4A,Rds-on:5Ω	TO-92	Apec	AP4002T
1	T1	EE16	Lp:1.755mH, Np:117turns(1 strand, 0.18mm), Ns:9turns(3 strand,0.3mm), Naux:20(1 strand, 0.18mm)	EE16 (8 pins)		
1	IC1	HF0100HS	QR controller	SOIC8	MPS	HF0100HS
1	U1	MP26075	Cradle charger	QFN10	MPS	MP26075EQ
1	U2	PC817C	Photo coupler	DIP	Sharp	PC817C

PRINTED CIRCUIT BOARD LAYOUT

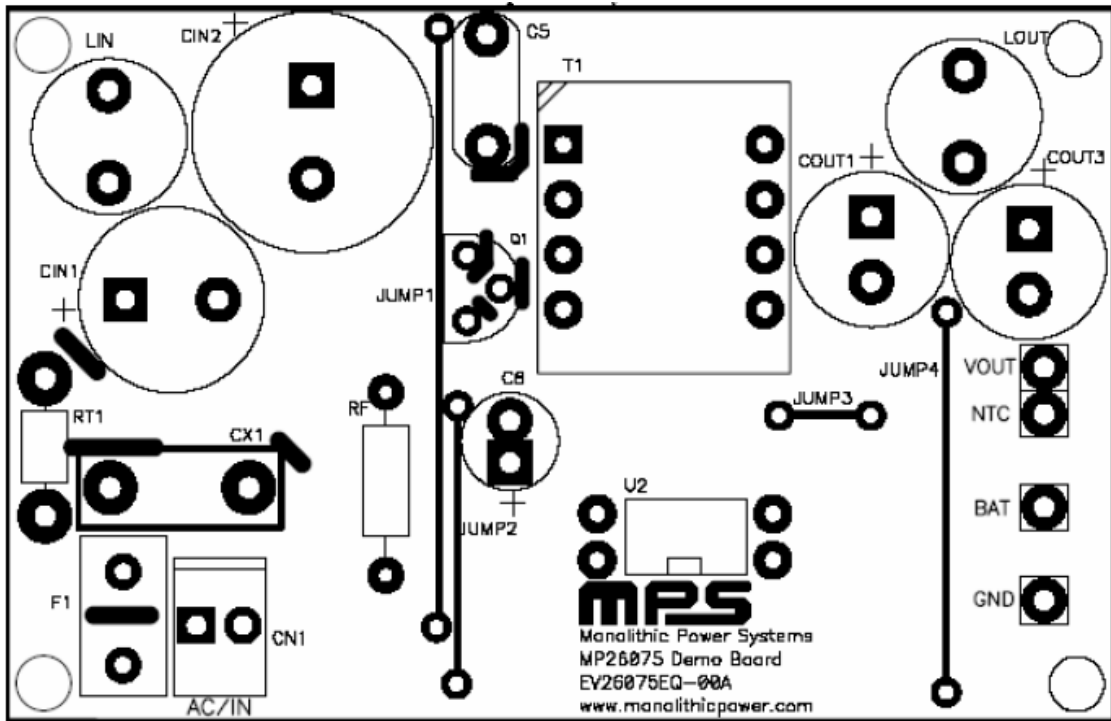
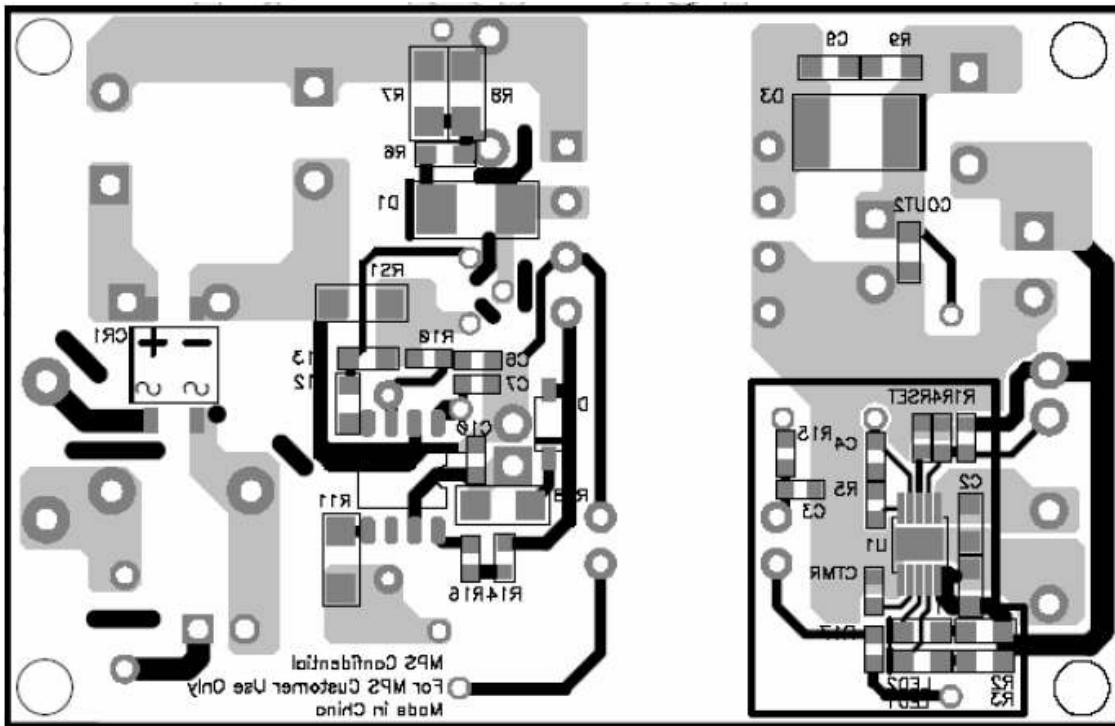

Figure 1—Top Silk



QUICK START GUIDE

1. Connect the positive terminal of the battery to BAT pin, and connect the negative terminal of the battery to GND pin.
2. Connect the AC Line terminals to CN1 port.
3. Turn the power supply on. The board will automatically startup.
4. The output voltage on this board is preset to 4.2V (for a single cell battery). The board layout accommodates most commonly used capacitors.
5. LEDs indicate the charge status and fault condition.

LED-Red	LED-Green	Status
Off	Off	Fault/toggle
On	Off	Normal charge
Off	On	End of charge

6. The charging Current is set at 1A, it can be programmed by RSET.

$$I_{\text{CHG}} = \frac{1.23}{\text{RSET(k)}} \times 1400(\text{mA})$$

NOTICE: The information in this document is subject to change without notice. Please contact MPS for current specifications. Users should warrant and guarantee that third party Intellectual Property rights are not infringed upon when integrating MPS products into any application. MPS will not assume any legal responsibility for any said applications.