

PART NUMBER CODING

G E DHRN-T941

PLATING

(ALL PLATINGS ARE LEAD FREE AND HAVE .000050" MIN NICKEL UNDERPLATE)

CONTACT SURFACE	TERMINATION
W = GOLD FLASH	.000100" PURE TIN, MATTE
B = .000010" GOLD	.000100" PURE TIN, MATTE
C = .000030" GOLD	.000100" PURE TIN, MATTE

POSITIONS

18
32
49
82

REVISIONS				
REV.	ECO. NO	DESCRIPTION	DATE	BY
E	2536	UPDATE PROCESSING TEMP FOR "N" MTL	3/30/2012	JH
F	2740	REMOVE 'NYLON 46' MATERIAL PART	04/24/2013	LH
H	3463	ADD NOTE 15	06/06/2016	LH

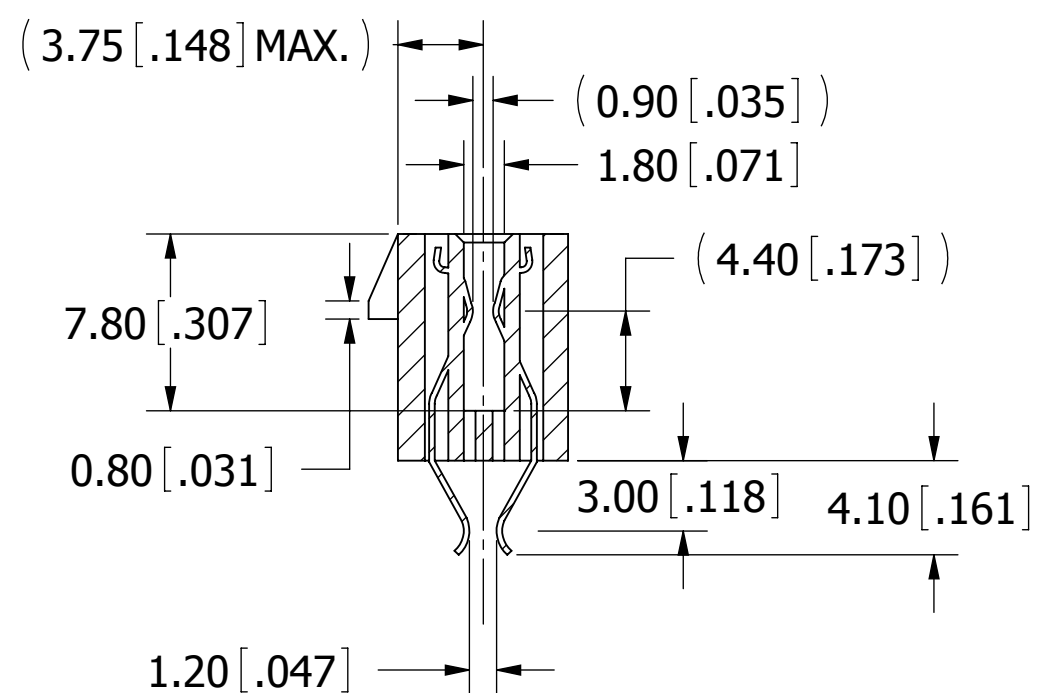
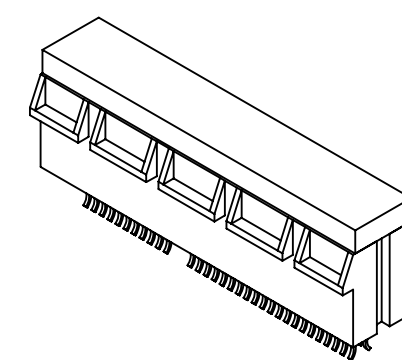
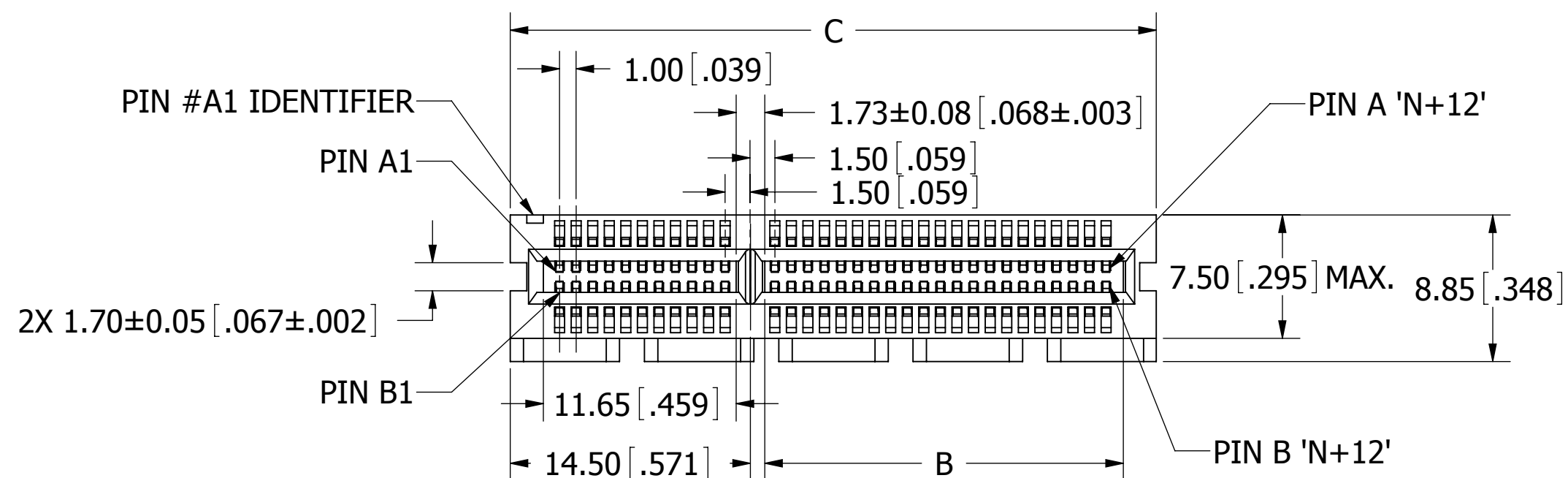

SECTION A-A

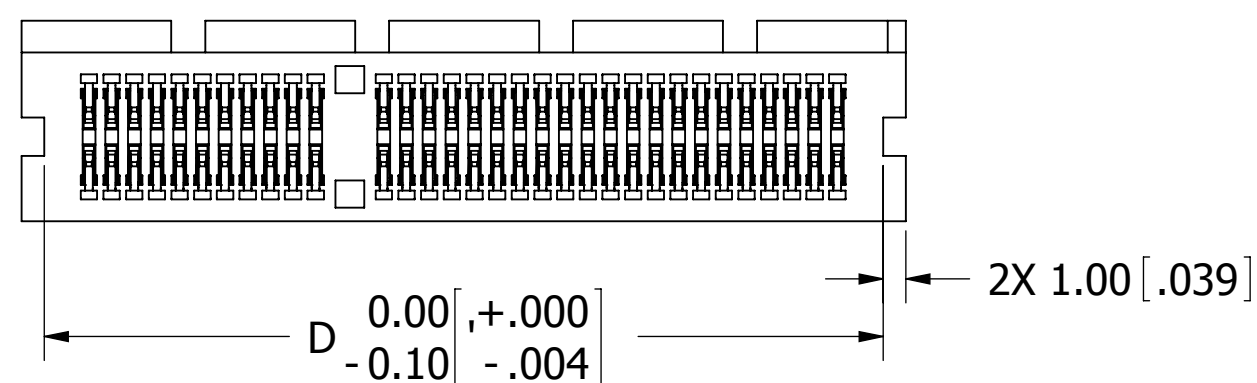
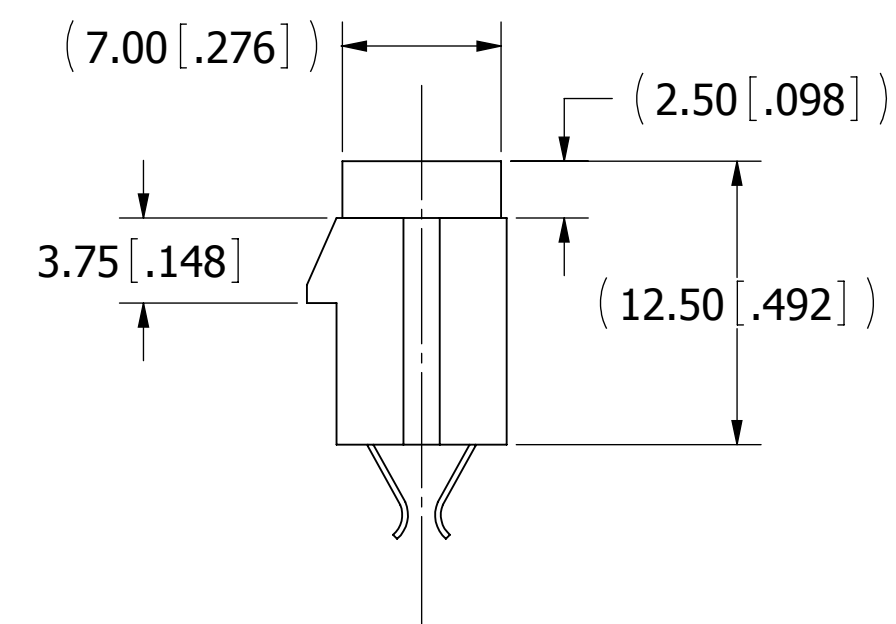
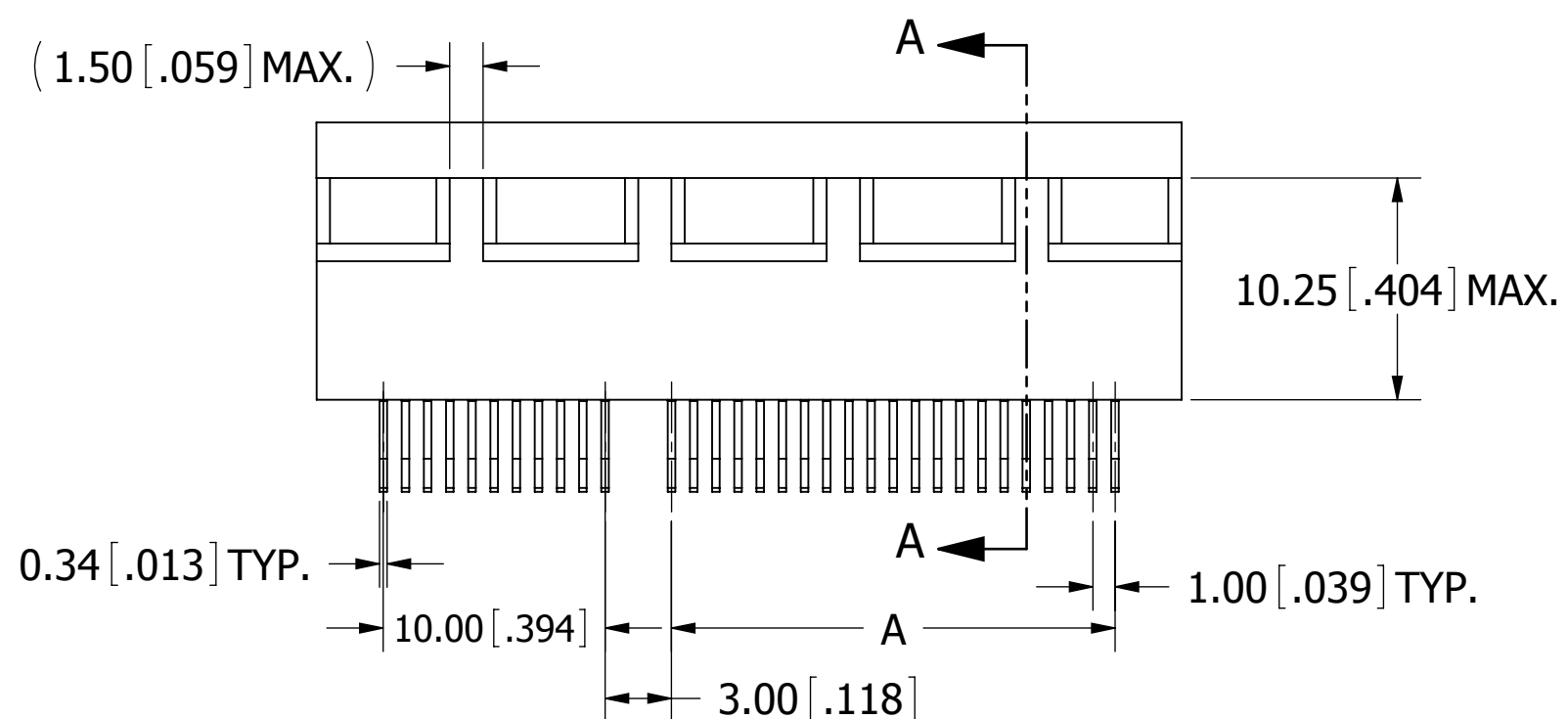

PART NUMBER	POSITIONS/ CONTACTS	A		B		C		D		E		G		H		SPACES 'N'	PIN "K"
		MM	INCH	MM	INCH	MM	INCH	MM	INCH	MM	INCH	MM	INCH	MM	INCH		
G_E18DHRN-T941	18/36	6.00	0.236	7.65	0.301	25.00	0.984	23.00	0.906	9.50	0.374	8.15	0.321	6.00	0.236	6	B17
G_E32DHRN-T941	32/64	20.00	0.787	21.65	0.852	39.00	1.535	37.00	1.457	23.50	0.925	22.15	0.872	20.00	0.787	20	B31
G_E49DHRN-T941	49/98	37.00	1.457	38.65	1.522	56.00	2.205	54.00	2.126	40.50	1.594	39.15	1.541	37.00	1.457	37	B48
G_E82DHRN-T941	82/164	70.00	2.756	71.65	2.821	89.00	3.504	87.00	3.425	73.50	2.894	72.15	2.841	70.00	2.756	70	B81

NOTES:

- INSULATOR MATERIAL: NYLON 9T, UL 94V-0, COLOR: BLACK.
- CONTACT MATERIAL: PHOSPHOR BRONZE.
- CONTACT PLATING: SEE PART NUMBER CODING.
- CURRENT RATING: 1.1 AMPS PER CONTACT.
- VOLTAGE RATING: 50 VAC/DC.
- INSULATOR RESISTANCE: 1000 MEGOHMS MIN.
- CONTACT RESISTANCE: 30 MILLI OHMS MAX.
- DIELECTRIC WITHSTANDING: 500 VAC.
- OPERATING TEMP.: -10°C TO + 85°C
- PROCESSING TEMP.: 260°C FOR 10 SEC. MAX.
- BOARD THICKNESS ACCOMMODATED: 1.57mm±0.13[.062±.005]
- INSERTION FORCE: 117.3g(1.173N) MAX PER CONTACT PAIR WHEN USING A 1.70mm[.067"] TEST BLADE.
- WITHDRAWAL FORCE: 15.31g(0.153N) MIN PER CONTACT PAIR USING A 1.44mm[.057"] PCB.
- CAP NEEDS TO BE ON DURING IR REFLOW PROCESS TO PREVENT WARPAGE.
- MATERIAL CODE "N" EQUIVALENT TO "G".

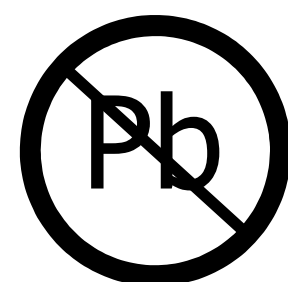

RoHS COMPLIANT

UNLESS OTHERWISE SPECIFIED:
DIMENSIONS ARE IN MM[INCHES]

TOLERANCES:

ANGULAR: ± 5°

.X= ± 0.35 [.014]
.XX= ± 0.25 [.010]
.XXX= ± 0.080 [.0031]

DRAWN	DATE	NAME
	07/08/09	JH

THE INFORMATION HEREIN CONTAINS PROPRIETARY INFORMATION OF SULLINS ELECTRONICS AND IS NOT TO BE REPRODUCED, USED OR DISCLOSED TO OTHERS FOR ANY PURPOSE EXCEPT AS SPECIFICALLY AUTHORIZED IN WRITING BY AN OFFICER OF SULLINS ELECTRONICS.

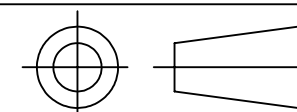

TITLE PCI E, STRADDLE MOUNT, NO PEGS

PART NUMBER G_E_DHRN-T941

SIZE	CAGE CODE	DWG. NO.	REV
C	54453	11044	H

SCALE: 3:1 SHEET 1 OF 2

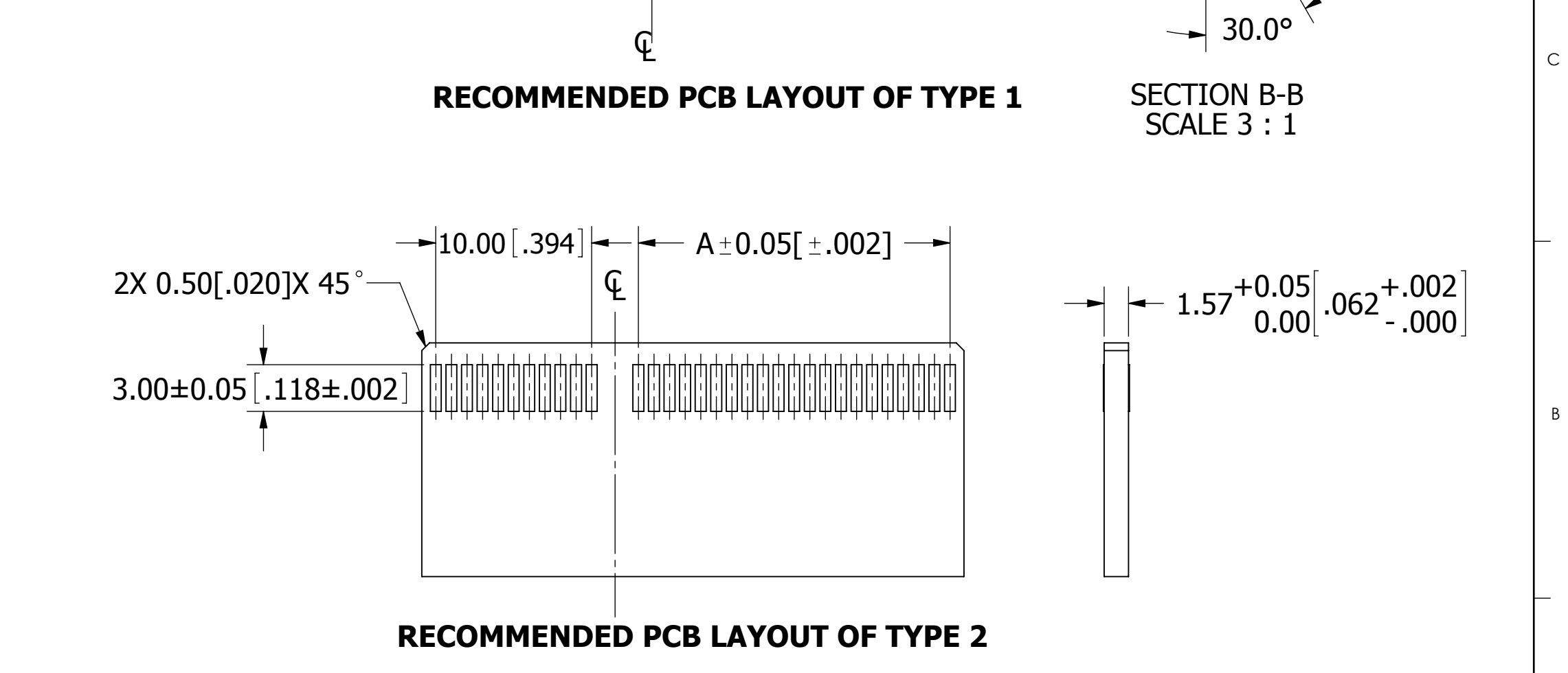
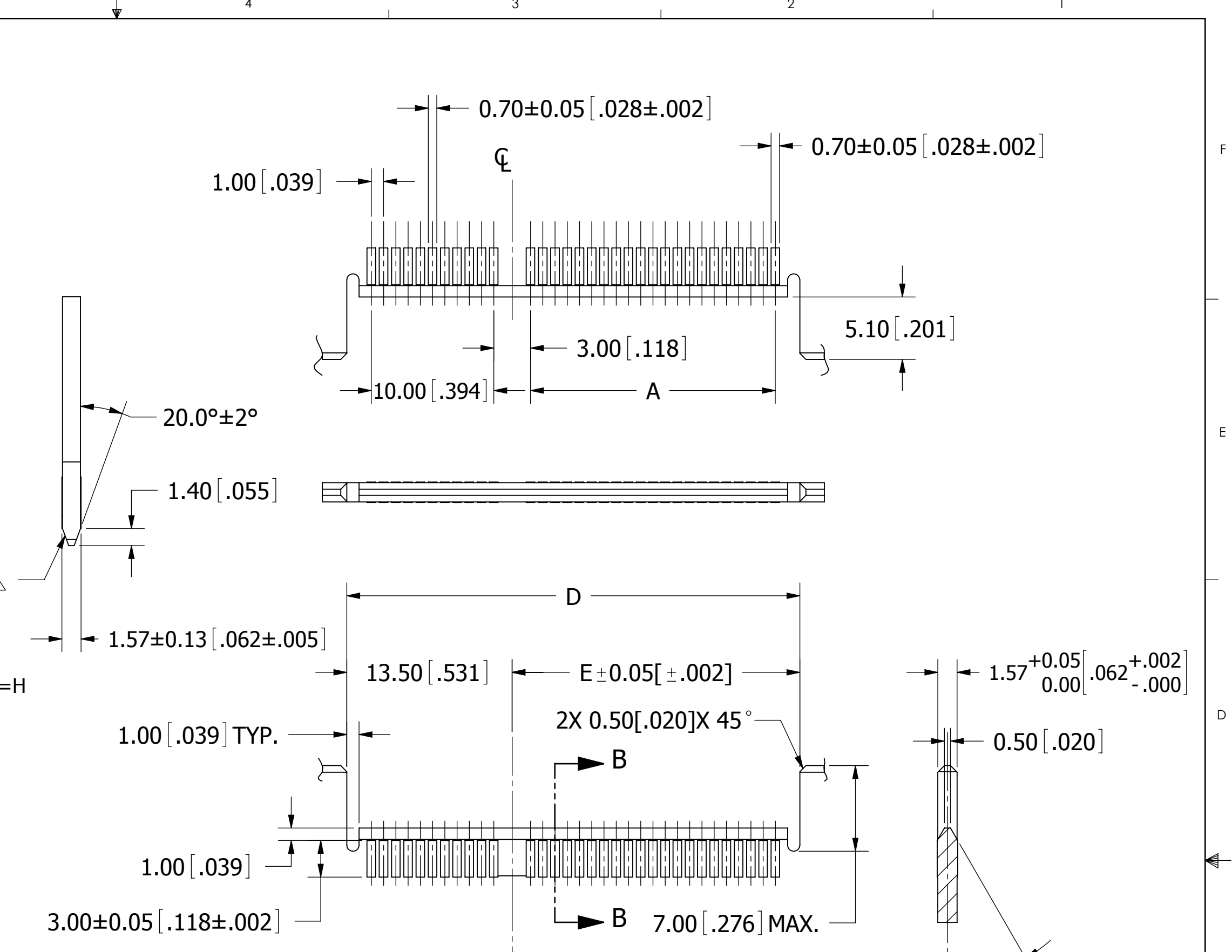
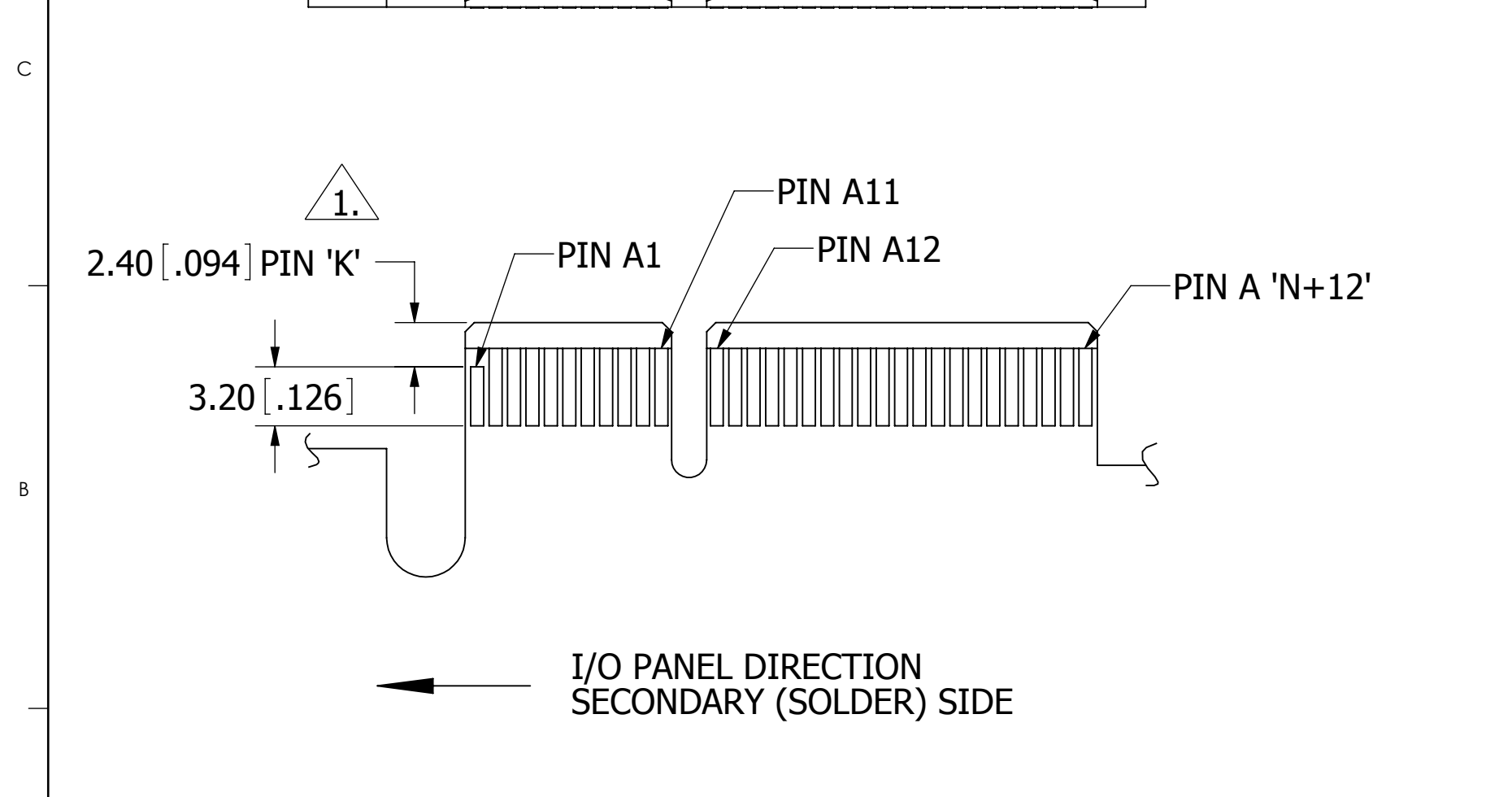
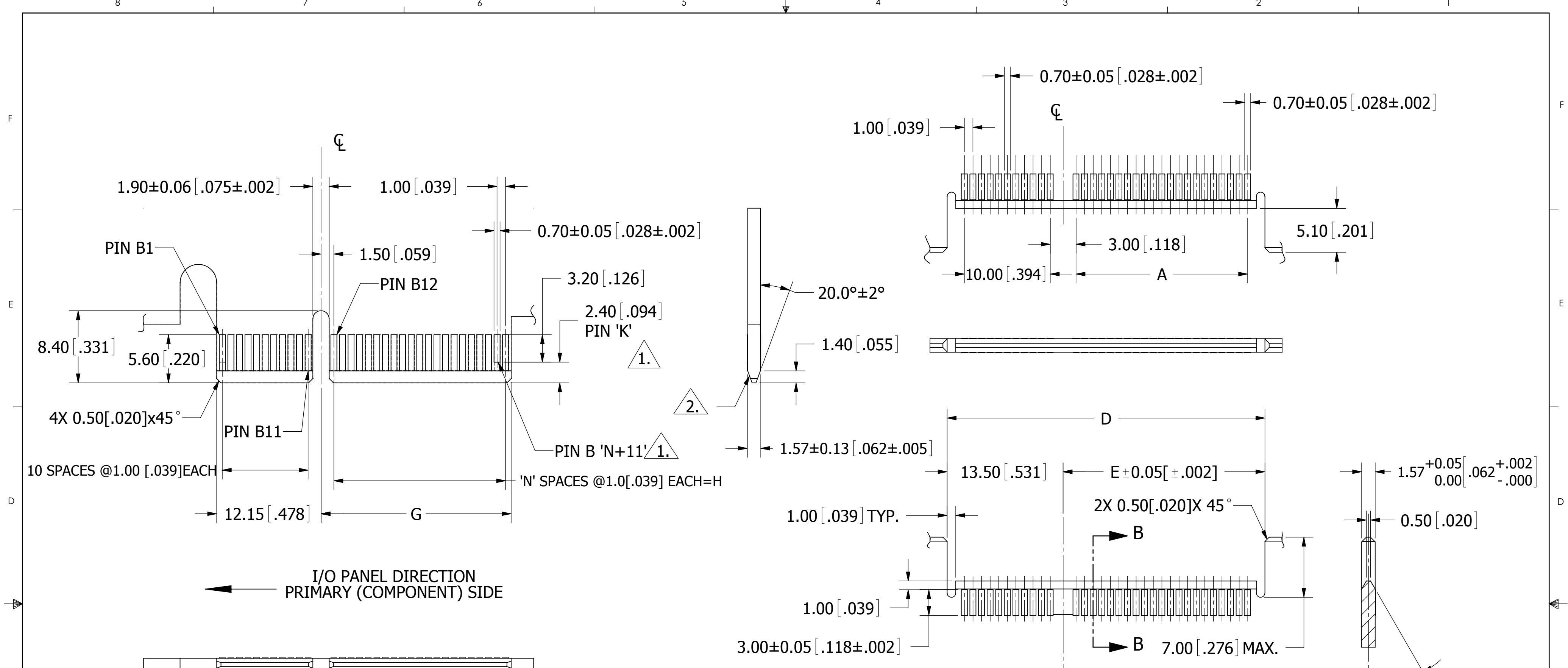

SECTION B-B
SCALE 3 : 1

UNLESS OTHERWISE SPECIFIED: DIMENSIONS ARE IN MM[INCHES]	DRAWN	DATE	NAME	
		07/08/09	JH	
TOLERANCES: ANGULAR: ± 5° .X = ± 0.35 [.014] .XX = ± 0.25 [.010] .XXX = ± 0.080 [.0031]	<small>THE INFORMATION HEREIN CONTAINS PROPRIETARY INFORMATION OF SULLINS ELECTRONICS AND IS NOT TO BE REPRODUCED, USED OR DISCLOSED TO OTHERS FOR ANY PURPOSE EXCEPT AS SPECIFICALLY AUTHORIZED IN WRITING BY AN OFFICER OF SULLINS ELECTRONICS.</small>			TITLE
				PCI E, STRADDLE MOUNT, NO PEGS PART NUMBER G_E_DHRN-T941
SIZE		CAGE CODE	DWG. NO.	REV
C		54453	11044	H
SCALE: 2:1			SHEET 2 OF 2	



- 1. NO TIE BAR PERMITTED FROM CARD EDGE TO LEADING EDGE OF PAD FOR PINS 'A1' AND 'K'.
- 2. CHAMFER EDGES MUST BE FREE OF CUTTING BURR.