



Reference Design Eval Kit STDP4028-RD1

RD1-4028

DVI to DisplayPort Converter

Kinetic Technologies cannot assume responsibility for use of any circuitry other than circuitry entirely embodied in a Kinetic Technologies product. No intellectual property or circuit patent licenses are implied. Kinetic Technologies reserves the right to change the circuitry and specifications without notice at any time

Contents

1. Purpose and Scope	4
2. Description.....	4
2.1. Set Up Instructions	5
2.1.1. I2C Host Port.....	5
2.1.2. In-System Programming (ISP)	6
2.1.3. Diagnosis	6
3. Board Description	7
3.1. Principal Components and Functions	9
3.2. Connector Descriptions	10
3.3. Switches	15
3.4. Stuffing Options	16
3.4.1. Single/dual bus TTL input	16
3.4.2. IROM/SPI-Flash	16

List of Tables

Table 3.1-1. Principal Components and Functions.....	9
Table 3.1-1. Principal Components and Functions (continue)	10

List of Figures

Figure 1. Connection Diagram: PC DVI Signal to DP Stream	5
Figure 2. Block Diagram	7
Figure 3. Board Picture	8

1. Purpose and Scope

This document provides description and setup instructions for the DisplayPort™ transmitter STDP4028 reference design board [RD1-4028_400-533] targeted for DVI to DP conversion applications.

2. Description

The STDP4028 is an integrated circuit featuring a four lane DisplayPort transmitter, quad LVDS /LVTTTL receiver with I2S, and SPDIF audio inputs for digital audio-video conversion application. This device also includes SPI interface, I2C Slave (Host Interface), I2C Master Interface, UART (GProbe) interface, and general-purpose IO pins. The RD1-4028 is a low cost compact four layer board that includes necessary interfaces and features to fully demonstrate the STDP4028 transmitter functionalities. The RD1-4028 board includes discrete TMDS receiver chips, converting DVI signal into LVTTTL input for STDP4028. This board is capable of handling both single link and dual link DVI input signals supporting video resolution from 640 x 480 up to 2560 x 1600. The RD1-4028 also features digital audio inputs SPDIF and I2S up to 8 Ch.

This reference design meets the following:

1. Stand-alone operation: Includes necessary firmware (either IROM or external SPI) to work independently; this means the intended functionalities are performed without depending on external controllers.
2. Slave configuration: Includes provision to configure the device by an external controller through the Host Interface to I2C.

2.1. Set Up Instructions

The picture below is a connection diagram showing the RD1-4028 board used for transferring a PC DVI signal into a DisplayPort stream. This board uses the standard DisplayPort connector recommended in the DP 1.1a specification to connect the DisplayPort output from the board to the input of the DisplayPort monitor.

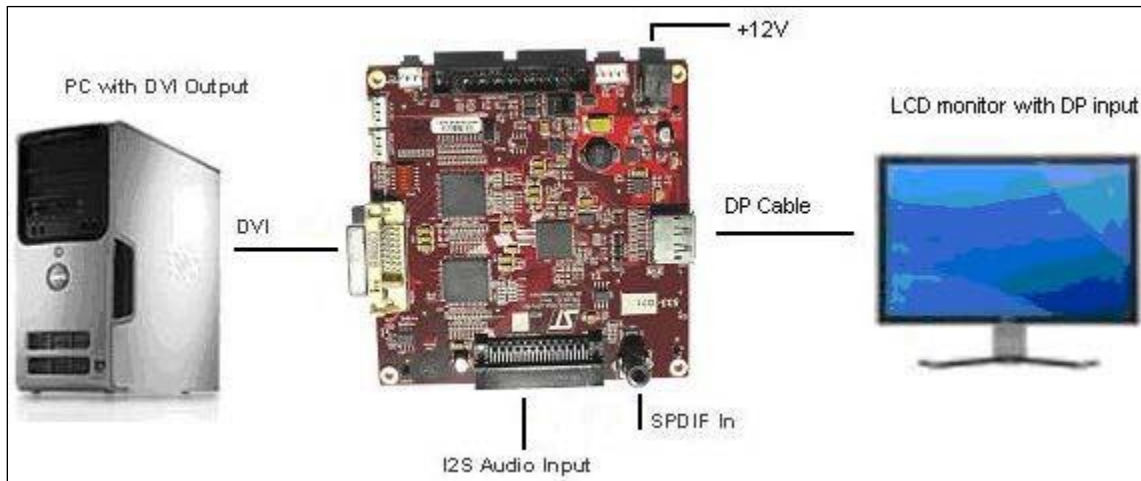

Figure 1. Connection Diagram: PC DVI Signal to DP Stream

1. Connect the DVI output from a PC source to the RD1-4028 reference board using a DVI cable.
2. Connect the output to a DisplayPort monitor using a DP cable. The RD1-4028 board supports both single link and dual link DVI.
3. Connect the 12 V (4A) DC power brick supplied for powering the board. An external digital audio (I2S or SPDIF) source is recommended for testing digital audio conversion by the STDP4028 device into DisplayPort output.
4. Once the connection is established, power ON the PC, monitor, RD1-4028 (DP transmitter) board. An image should pop up on the screen within 5-6 seconds.

Note: The default configuration is dual bus TTL (dual link DVI) video input and SPDIF audio in. For single bus TTL input (single link DVI), change the bootstrap setting Boot[5] to GND (populate R510 and remove 509). STDP4028 register setting changes are required in order to receive audio on I2S input. This can be done through I2C host configuration or through firmware changes.

The RD1-4028 supports video resolution from 640 x 480 up to 2560 x 1600 and audio up to 8 Ch.

2.1.1. I2C Host Port

Host connector (CN901) allows configuration of the STDP4028 IC from an external host (microcontroller) through conventional I2C interface. User can plug two wires into pin 5 and pin 6 of this connector to access the I2C port of the chip. STDP4028 default device ID is 0xE6/0xE7, but can be changed through bootstrap settings. Refer to the STDP4028 datasheet for further details.

2.1.2. In-System Programming (ISP)

RD1-4028 uses SPI Flash to store the firmware. In case of a new firmware upgrade, the following method should be used.

- ISP through UART connector: Allows programming the SPI Flash through UART (RS232) connector. Requires GProbe board (RS232 converter circuit) and GProbe software tool (contact Kinetic).

2.1.3. Diagnosis

If the image does not come up, follow the steps below for diagnosis.

Note: The diagnosis requires the Kinetic GProbe software and hardware tool. Contact Kinetic for the GProbe software and board.

1. Install the GProbe diagnostic tool on a computer and set the baud rate to 115,200.
2. Connect GProbe board (not supplied) to the serial port (or USB port if using USB version) of the computer.
3. Connect the other end of the GProbe board to connector (CN902) on the RD1-4028 board using 4-wire cable (part of the GProbe board).

Note: CHECK POLARITY while connecting the cable; Pin 1 is marked on the board. The 4-wire cable connection from CN504 to GProbe board is 1 to 1.

4. Hit the Reset button on the board (RESET SW901). You will see the firmware version and date of firmware in the GProbe window. This indicates the DP receiver IC is functional. If the message does not appear, reprogram the Flash using the ISP method described in the GProbe user guide.
5. Using an oscilloscope, check the video input and output from the STDP4028.

Note: Refer to the STDP4028 datasheet for pinout descriptions.

3. Board Description

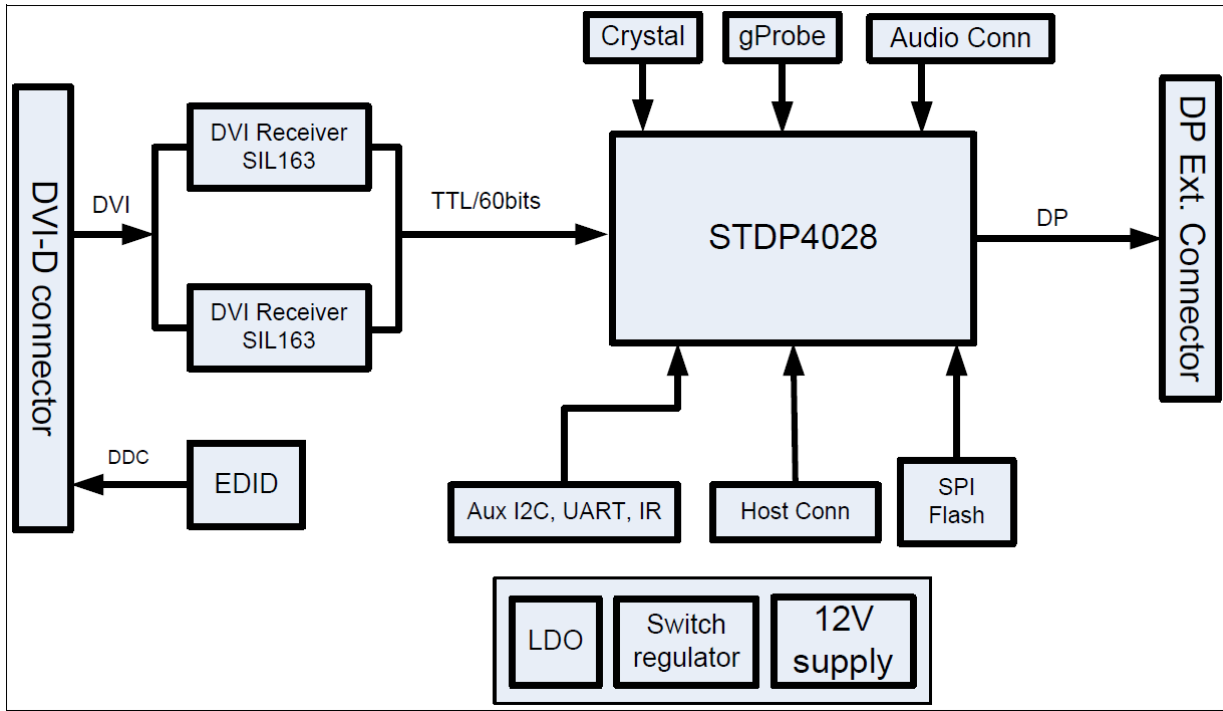

Figure 2. Block Diagram

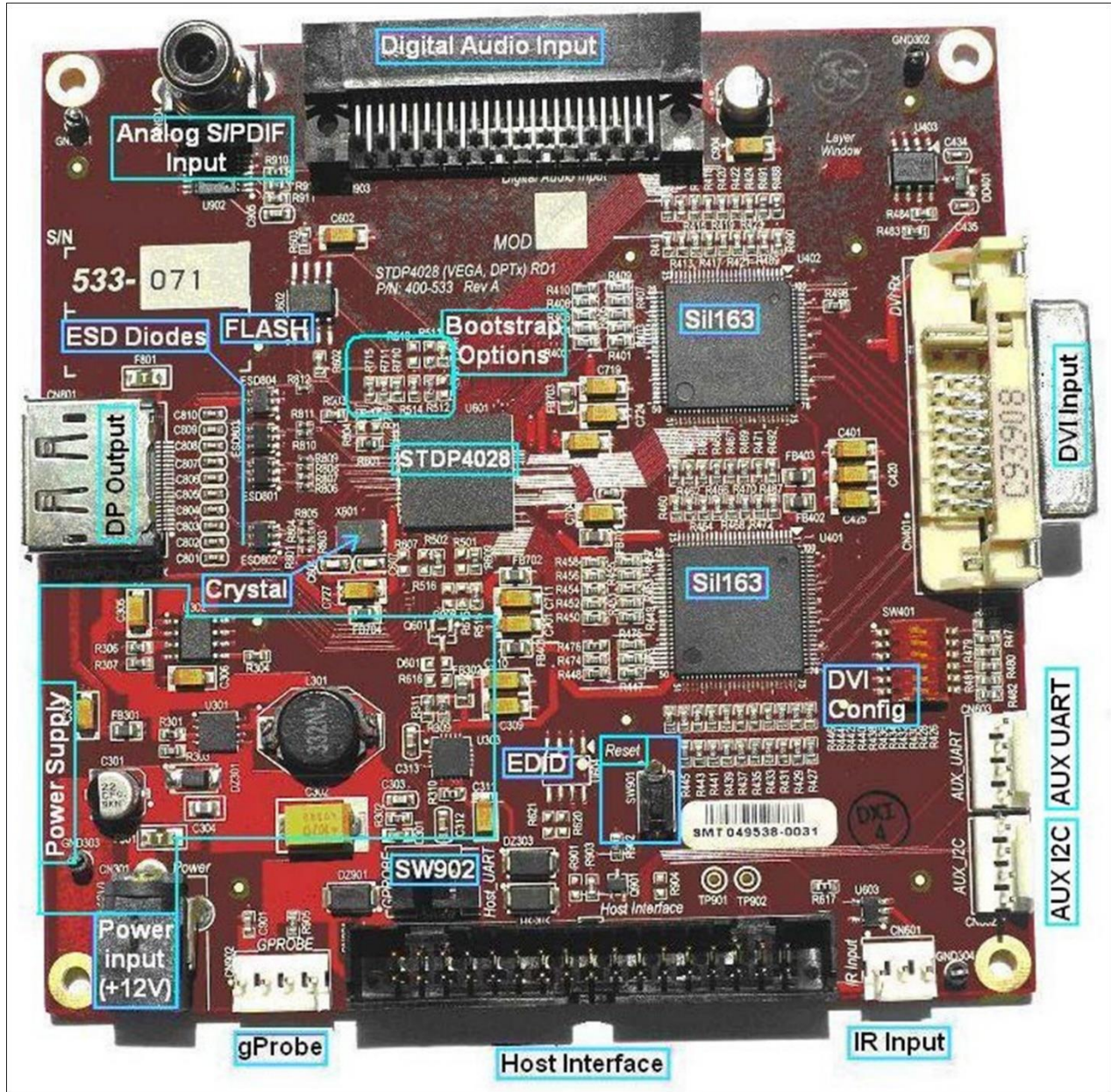

Figure 3. Board Picture

3.1. Principal Components and Functions

Below is a summary of all necessary connectors, switches, and other components. Please refer to the latest board schematics for further details.

Table 3.1-1. Principal Components and Functions

Label	Description	RefDes
Power Input (+12V)	Input 12 V, down conversion to 5 V, 3.3 V, and 1.2 V. This board uses a switch regulator for 5 V and an LDO [low-dropout] for 3.3 V and 1.2 V. Note the analog and digital supplies (3.3A and 3.3D or 1.2A and 1.2D) are isolated using ferrite beads.	CN301
STDP4028	The STDP4028 is capable of receiving and converting LVTTTL video and I2S (or SPDIF) audio input into a DisplayPort output. This device offers LVTTTL input interface configurable to map a wide range of display controller products. The 60-bit LVTTTL input ports on STDP4028 can be mapped to transfer video data either in two pixels per clock or single pixel per clock of a chosen color depth.	U601
DP Output	DisplayPort output connector	CN801
Flash	The board includes an SPI Flash of 2 MB to hold the firmware. The SPI Flash can be programmed (ISP) through UART interface	U602
DVI In	DVI Input connector	CN401
Sil163	DVI Receivers: The 48-bit TTL video output from DVI receivers are connected to the STDP4028. By default, DVI input is configured for a single link operation up to 165 MHz. In this case, both transmitters are operating at half the clock rate. A custom configuration is required for handling higher speed signals, such as WQXGA resolution. (Contact your local Kinetic FAE for support.)	U401 U402
Digital Audio Input	The I2S (8 channel) or S/PDIF (single wire, 3.3 V) audio input signals from the external audio Codec card are received by CN903.	CN903
Analog S/PDIF Input	Standard S/PDIF input connector.	CN904
Host Interface	Host Interface (I2C): This board includes a provision to access the STDP4028 device from an external host controller through the Host Interface (I2C port) connection.	CN901
GProbe	GProbe Interface (+3.3V logic): the board also includes a GProbe connector that connects to the STDP4028 UART port for communication with external PC sources for debug purposes. The Kinetic GProbe tool (software) and PC serial port interface board together create a debug environment for device debug and firmware update. The GProbe interface is also used for ISP purposes.	CN902
Reset	Reset Button, when pressed, triggers a system master reset through the internal reset circuitry. The reset button is used for system reset and debugging purposes and is not required for production board design as the STDP4028 produces an internal reset during power ON.	SW901
IR Input	An IR connector for interfacing the IR receiver.	CN601
AUX_I2C	A simplified connector for Host Interface debug	CN602
AUX_UART	UART Interface (for UART-over-Aux testing)	CN603
LED	Single LED for indicating the power on status.	D301
EDID	EDID Option: Currently not populated to allow pass through.	U604
Crystal	An external crystal of 27 MHz. The design makes use of internal oscillator circuitry.	X601
ESD Diodes	ESD protection diodes for DisplayPort signal (main lanes, AUX, and HPD line). The board implements low cost ESD diodes.	ESD801 ESD802 ESD803 ESD804
SW902	Switches UART between Host Interface & GProbe Interface (see mark on PCB).	SW902

Table 3.1-2. Principal Components and Functions (continue)

Label	Description	RefDes
DVI Config	The RD1-4028 board has a switch for DVI transmitter hardware configuration. The switch SW401 controls DVI Receivers U401 and U402. The switch position is logic HIGH, which is set for dual pixel input mode of operation with rising edge data sampling. The switch definitions are described in section 4.3.	SW401
Bootstrap Options	The bootstrap options can be configured for: <ul style="list-style-type: none"> – IROM/SPI Flash – Single/Dual TTL Refer to the datasheet for more details.	R503 R504 R509 R510

3.2. Connector Descriptions

The RD1-4028 has the following connectors. The locations of these connectors are shown in the board picture in Figure 3.

CN301 – +12V DC 4A Power Input Jack

CN902 – GProbe Interface (4x1 pin keyed header) connects to the UART port of the STDP4028. Use the Kinetic GProbe board and interface cable for connecting the board to an external PC that has GProbe software running.

Pin 1	+5V
Pin 2	GPROBE_TX
Pin 3	GPROBE_RX
Pin 4	GND

CN901 – I2C Host Interface (header 17X2) connector for connecting external host. This is used only when an external host controller accesses the DisplayPort transmitter; not used for normal operation. In normal operation, internal MCU controls the overall functioning of the DisplayPort Transmitter (refer to the schematics for complete pin description for the Host Interface).

Pin 1 & 2	+5V
Pin 3 & 4	GND
Pin 5	AUX_I2C_SCL
Pin 6	AUX_I2C_SDA
Pin 7	HOST_TX
Pin 8	HOST_RX
Pin 9	RESET from Host
Pin 10	NC
Pin 11 & 12	GND
Pin 13	AUX_UART_TX
Pin 14	AUX_UART_RX
Pin 15	I2C_SCL
Pin 16	I2C_SDA
Pin 17 & 18	NC
Pin 19 & 20	GND
Pin 21 & 22	NC
Pin 23	IRQ/BOOT7
Pin 24	IR_IN
Pin 25 & 26	NC
Pin 27 & 28	GND
Pin 29	GPIO_3/BOOT6
Pin 30	GPIO_0/BOOT3
Pin 31	TP901
Pin 32	GPIO_1/BOOT2
Pin 33	TP902
Pin 34	GPIO_2/BOOT5

CN801 – DisplayPort connector. Pin out details are shown below.

Pin 1	ML_Lane 0(p)
Pin 2	GND
Pin 3	ML_Lane 0 (n)
Pin 4	ML_Lane 1 (p)
Pin 5	GND
Pin 6	ML_Lane 1 (n)
Pin 7	ML_Lane 2 (p)
Pin 8	GND
Pin 9	ML_Lane 2 (n)
Pin 10	ML_Lane 3 (p)
Pin 11	GND
Pin 12	ML_Lane 3 (n)
Pin 13	GND
Pin 14	GND
Pin 15	AUX_CH (p)
Pin 16	GND
Pin 17	AUX_CH (n)
Pin 18	Hot Plug Detect
Pin 19	Return (GND)
Pin 20	DP_PWR
Pin 11	GND

CN401 – DVI-D input dual link DVI connector. Pin out description for the DVI connector is shown below.

Pin 1	RX2-
Pin 2	RX2+
Pin 3	GND
Pin 4	S_RX1-
Pin 5	S_RX1+
Pin 6	DVI_SCL
Pin 7	DVI_SDA
Pin 8	NC
Pin 9	RX1-
Pin 10	RX1+
Pin 11	GND
Pin 12	S_RX0-
Pin 13	S_RX0+
Pin 14	DVI_+5V
Pin 15	GND
Pin 16	+5V
Pin 17	RX0-
Pin 18	RX0+
Pin 19	GND
Pin 20	S_RX2-
Pin 21	S_RX2+
Pin 22	GND
Pin 23	RXC+
Pin 24	RXC-
Pin C1 through C5	NC

CN904 – SPDIF Input connector. The pin out description is shown below.

Pin 1	GND
Pin 2	I2S_0
Pin 3	GND

CN903 – I2S Digital Audio Input (52 pin) connector.

Pin A1	NC
Pin A2 & A3	GND
Pin A4 through A6	NC
Pin A7	GND
Pin A8 & A9	NC
Pin A10	I2S_3
Pin A11	I2S_2
Pin A12	I2S_1
Pin A13	NC
Pin A14	I2S_0
Pin A15	DNP
Pin A16 & A17	GND
Pin A18 through A21	NC
Pin A22	I2S_BCLK
Pin A23	+5V
Pin A24	I2S_WCLK
Pin A25 & A26	+5V
Pin B1	GND
Pin B2 & B3	NC
Pin B4 & B5	GND
Pin B6 & B7	NC
Pin B8 & B9	GND
Pin B10 through B13	NC
Pin B14 & B15	GND
Pin B16 through B18	NC
Pin B19 & B20	GND
Pin B21	+12V
Pin B22	NC
Pin B23	+12V
Pin B24	NC
Pin B25	+12V
Pin B26	GND

CN602 – I2C Host Interface (similar to CN901 with four pin header only, simplified version for debug purposes)

Pin 1	+5V
Pin 2	I2C_SCL
Pin 3	I2C_SDA
Pin 4	GND

CN603 – UART Interface (for UART-over-Aux testing)

Pin 1	+5V
Pin 2	Aux_UART_TX
Pin 3	Aux_UART_RX
Pin 4	GND

3.3. Switches

DVI Configuration Switch (SW401): The RD1-4028 board has a switch for DVI transmitter hardware configuration. The switch SW401 controls DVI Receivers U401 and U402. The switch position is logic HIGH, which is set for dual pixel input mode of operation with rising edge data sampling. The switch definitions of SW401 are described below.

SW	Name	Definitions
SW401.1 SW401.2	/ODCLK_INV	1: Inverted ODCLK 0: Normal ODCLK
SW401.3 SW401.4	ST	1: High Output Drive Strength 0: Low Output Drive Strength
SW401.5	PIXS/M_S	1: 2-pixel/clock when in single link 0: 1-pixel/clock when in single link
SW401.6	STAG_OUT	1: Normal Simultaneous Outputs (EVEN & ODD) 0: Staggered Output

Host Interface Switch (SW902): This switch selects the use of GProbe connector or Host Interface connector.

SW901.1	HOST_TX
SW901.2	UART_TX
SW901.3	GPROBE_TX
SW901.4	HOST_RX
SW901.5	UART_RX
SW901.6	GPROBE_TX

3.4. Stuffing Options

3.4.1. Single/dual bus TTL input

Single TTL configuration: stuff R510, unstuff R509

Dual TTL configuration: stuff R509, unstuff R510

3.4.2. IROM/SPI-Flash

OCM boot from IROM code: stuff R504, unstuff R503

OCM boot from external ROM code: stuff R503, unstuff R504