

bq29700 Single-cell Li-Ion Protector EVM

The bq29700 EVM is a complete evaluation system for the bq297xy family of second-level protectors. The EVM includes one bq29700-based circuit module.

Contents

1	Features.....	1
2	bq29700-Based Circuit Module	2
3	bq29700 Circuit Module Schematic	2
4	Circuit Module Physical Layouts and Bill of Materials	3
5	EVM Hardware and Software Setup	4

List of Figures

1	bq29700 Schematic	2
2	Top Assembly	3
3	Top Layer	3
4	Bottom Layer	3
5	bq29700 Circuit Module Connection to Cell and System Load/Charger	5

List of Tables

1	Ordering Information	1
2	Bill of Materials	4

1 Features

- bq29700-based circuit module
- Link to support documentation

1.1 Ordering Information

Table 1. Ordering Information

EVM Part Number	Chemistry	Configuration	Capacity
bq29700EVM-610	Li-Ion	1-Series Cell	Any

2 bq29700-Based Circuit Module

The bq29700-based circuit module is a complete and compact example solution of a bq29700 battery protection IC. The circuit module includes one bq29700 IC, charge and discharge FETs, and all other onboard components necessary to use and interface with the protector. The circuit module connects directly across the battery.

2.1 Circuit Module Connections

Contacts on the circuit module provide the following connections:

- Direct connection to the cell: Cell+, Cell-
- The system load and charger connect across Pack+ and Pack-

2.2 Pin Descriptions

PIN NAME	DESCRIPTION
Cell-	Cell negative terminal
Cell+	Cell positive terminal
Pack-	Load or charger negative terminal
Pack+	Load or charger positive terminal

3 bq29700 Circuit Module Schematic

This section contains information on the schematic for the bq29700 implementation.

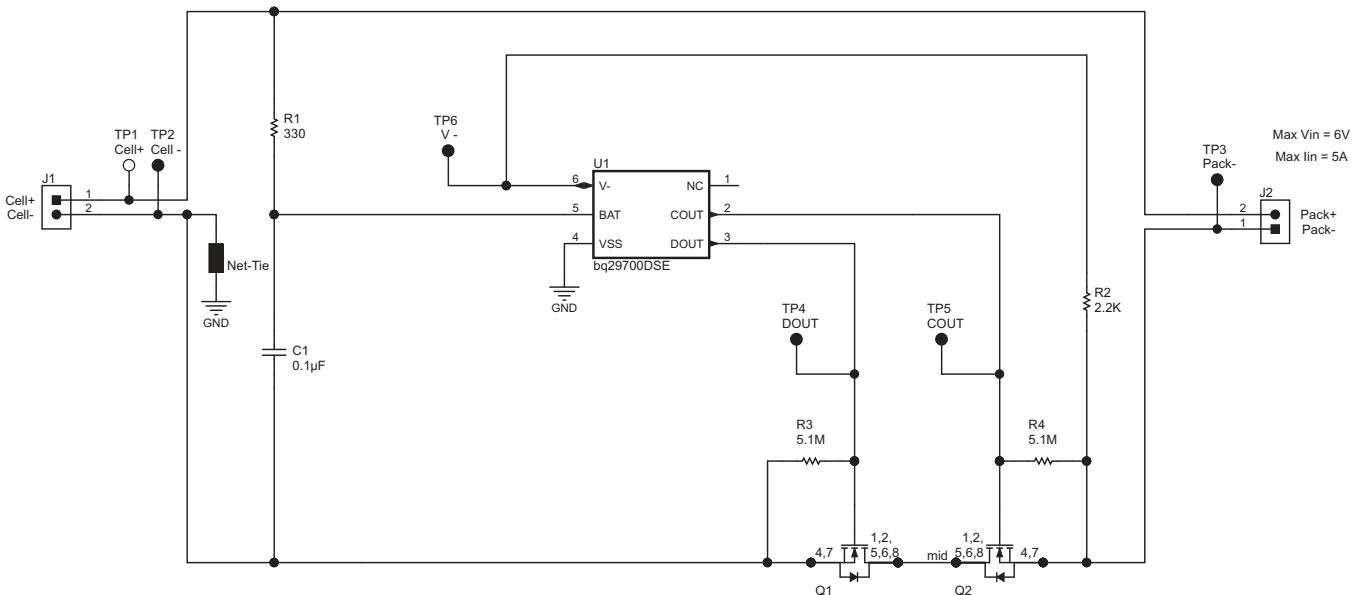

Figure 1. bq29700 Schematic

3.1 Charge and Discharge FETs

The bq29700 protector has the capability to control low-side charge and discharge FETs. These FETs have been included on the EVM board module. Test points TP4 and TP5 have been provided to allow for easy gate-to-source measurements.

NOTE: TP4 and TP6 test points are swapped on the A version of the EVM silk screen. TP4 should be DOUT and TP6 should be V-.

4 Circuit Module Physical Layouts and Bill of Materials

This section contains the board layout, bill of materials, and assembly drawings for the bq29700 circuit module.

4.1 Board Layout

This section shows the dimensions, PCB layers, and assembly drawing for the bq29700 module.

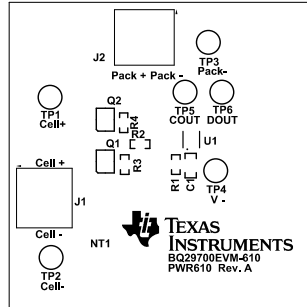

Figure 2. Top Assembly

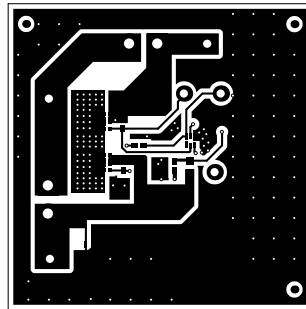

Figure 3. Top Layer

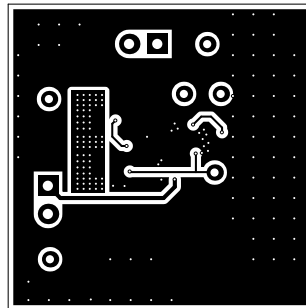

Figure 4. Bottom Layer

4.2 Bill of Materials

Table 2. Bill of Materials

Designator	Quantity	Value	Description	Package Reference	Part Number	Manufacturer
PCB1	1		Printed Circuit Board		PWR610	Any
C1	1	0.1 μ F	CAP, CERM, 0.1 μ F, 50V, \pm 10%, X7R, 0603	0603	GRM188R71H104KA93D	MuRata
J1, J2	2		Terminal Block, 6A, 3.5mm Pitch, 2-Pos, TH	7.0 x 8.2 x 6.5 mm	ED555/2DS	On-Shore Technology
Q1, Q2	2	25 V	MOSFET, N-CH, 25V, 5A, SON 2x2 mm	SON 2x2 mm	CSD16301Q2	Texas Instruments
R1	1	330	RES, 330 ohm, 5%, 0.063W, 0402	0402	CRCW0402330RJNED	Vishay-Dale
R2	1	2.2 k Ω	RES, 2.2 kohm, 5%, 1/16W, 0402	0402	CRCW04022K20JNED	Vishay Dale
R3, R4	2	5.1 M Ω	RES, 5.1 Mohm, 5%, 1/16W, 0402	0402	RC1005J515CS	Samsung Electromechanics
TP1	1	Red	Test Point, Miniature, Red, TH	Red Miniature Test point	5000	Keystone
TP2, TP3, TP4, TP5, TP6	5	Black	Test Point, Miniature, Black, TH	Black Miniature Test point	5001	Keystone
U1	1		Li-Ion/Li Polymer Battery Protection IC, DSE0006A	DSE0006A	bq29700DSE	Texas Instruments

4.3 bq29700 Circuit Module Performance Specification Summary

This section summarizes the performance specifications of the bq29700 circuit module.

Performance Specification Summary

Specification	Min	Typ	Max	Unit
Input voltage Pack+ to Pack-	0	4	6	V
Charge and discharge current	0	1	5	A

5 EVM Hardware and Software Setup

This section describes how to connect the different components of the bq29700 EVM. [Figure 5](#) shows how to connect the bq29700 circuit module to the cell and system load or charger.

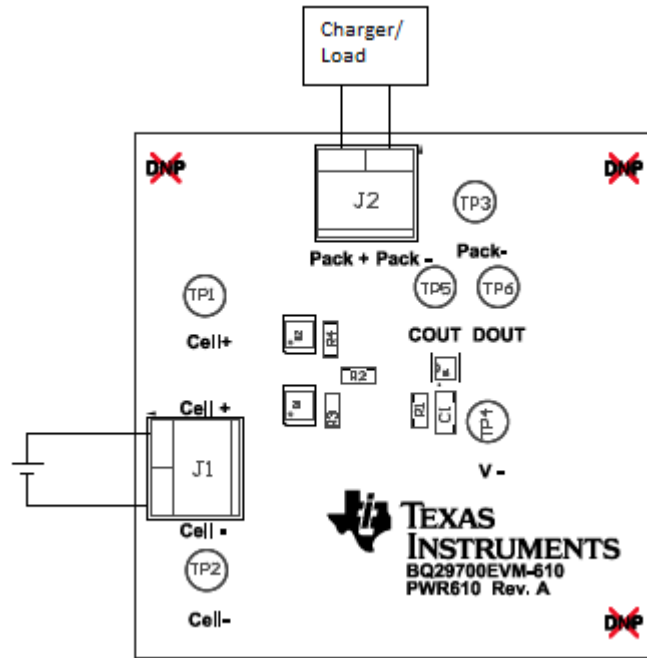

Figure 5. bq29700 Circuit Module Connection to Cell and System Load/Charger

Evaluation Board/Kit Important Notice

Texas Instruments (TI) provides the enclosed product(s) under the following conditions:

This evaluation board/kit is intended for use for **ENGINEERING DEVELOPMENT, DEMONSTRATION, OR EVALUATION PURPOSES ONLY** and is not considered by TI to be a finished end-product fit for general consumer use. Persons handling the product(s) must have electronics training and observe good engineering practice standards. As such, the goods being provided are not intended to be complete in terms of required design-, marketing-, and/or manufacturing-related protective considerations, including product safety and environmental measures typically found in end products that incorporate such semiconductor components or circuit boards. This evaluation board/kit does not fall within the scope of the European Union directives regarding electromagnetic compatibility, restricted substances (RoHS), recycling (WEEE), FCC, CE or UL, and therefore may not meet the technical requirements of these directives or other related directives.

Should this evaluation board/kit not meet the specifications indicated in the User's Guide, the board/kit may be returned within 30 days from the date of delivery for a full refund. **THE FOREGOING WARRANTY IS THE EXCLUSIVE WARRANTY MADE BY SELLER TO BUYER AND IS IN LIEU OF ALL OTHER WARRANTIES, EXPRESSED, IMPLIED, OR STATUTORY, INCLUDING ANY WARRANTY OF MERCHANTABILITY OR FITNESS FOR ANY PARTICULAR PURPOSE.**

The user assumes all responsibility and liability for proper and safe handling of the goods. Further, the user indemnifies TI from all claims arising from the handling or use of the goods. Due to the open construction of the product, it is the user's responsibility to take any and all appropriate precautions with regard to electrostatic discharge.

EXCEPT TO THE EXTENT OF THE INDEMNITY SET FORTH ABOVE, NEITHER PARTY SHALL BE LIABLE TO THE OTHER FOR ANY INDIRECT, SPECIAL, INCIDENTAL, OR CONSEQUENTIAL DAMAGES.

TI currently deals with a variety of customers for products, and therefore our arrangement with the user **is not exclusive.**

TI assumes **no liability for applications assistance, customer product design, software performance, or infringement of patents or services described herein.**

Please read the User's Guide and, specifically, the Warnings and Restrictions notice in the User's Guide prior to handling the product. This notice contains important safety information about temperatures and voltages. For additional information on TI's environmental and/or safety programs, please contact the TI application engineer or visit www.ti.com/esh.

No license is granted under any patent right or other intellectual property right of TI covering or relating to any machine, process, or combination in which such TI products or services might be or are used.

FCC Warning

This evaluation board/kit is intended for use for **ENGINEERING DEVELOPMENT, DEMONSTRATION, OR EVALUATION PURPOSES ONLY** and is not considered by TI to be a finished end-product fit for general consumer use. It generates, uses, and can radiate radio frequency energy and has not been tested for compliance with the limits of computing devices pursuant to part 15 of FCC rules, which are designed to provide reasonable protection against radio frequency interference. Operation of this equipment in other environments may cause interference with radio communications, in which case the user at his own expense will be required to take whatever measures may be required to correct this interference.

EVM Warnings and Restrictions

It is important to operate this EVM within the input voltage range of 0 V to 18 V and the output voltage range of (N/A).

Exceeding the specified input range may cause unexpected operation and/or irreversible damage to the EVM. If there are questions concerning the input range, please contact a TI field representative prior to connecting the input power.

Applying loads outside of the specified output range may result in unintended operation and/or possible permanent damage to the EVM. Please consult the EVM User's Guide prior to connecting any load to the EVM output. If there is uncertainty as to the load specification, please contact a TI field representative.

During normal operation, some circuit components may have case temperatures greater than 60°C. The EVM is designed to operate properly with certain components above 60°C as long as the input and output ranges are maintained. These components include but are not limited to linear regulators, switching transistors, pass transistors, and current sense resistors. These types of devices can be identified using the EVM schematic located in the EVM User's Guide. When placing measurement probes near these devices during operation, please be aware that these devices may be very warm to the touch.

Mailing Address: Texas Instruments, Post Office Box 655303, Dallas, Texas 75265
Copyright © 2014, Texas Instruments Incorporated

IMPORTANT NOTICE

Texas Instruments Incorporated and its subsidiaries (TI) reserve the right to make corrections, enhancements, improvements and other changes to its semiconductor products and services per JESD46, latest issue, and to discontinue any product or service per JESD48, latest issue. Buyers should obtain the latest relevant information before placing orders and should verify that such information is current and complete. All semiconductor products (also referred to herein as "components") are sold subject to TI's terms and conditions of sale supplied at the time of order acknowledgment.

TI warrants performance of its components to the specifications applicable at the time of sale, in accordance with the warranty in TI's terms and conditions of sale of semiconductor products. Testing and other quality control techniques are used to the extent TI deems necessary to support this warranty. Except where mandated by applicable law, testing of all parameters of each component is not necessarily performed.

TI assumes no liability for applications assistance or the design of Buyers' products. Buyers are responsible for their products and applications using TI components. To minimize the risks associated with Buyers' products and applications, Buyers should provide adequate design and operating safeguards.

TI does not warrant or represent that any license, either express or implied, is granted under any patent right, copyright, mask work right, or other intellectual property right relating to any combination, machine, or process in which TI components or services are used. Information published by TI regarding third-party products or services does not constitute a license to use such products or services or a warranty or endorsement thereof. Use of such information may require a license from a third party under the patents or other intellectual property of the third party, or a license from TI under the patents or other intellectual property of TI.

Reproduction of significant portions of TI information in TI data books or data sheets is permissible only if reproduction is without alteration and is accompanied by all associated warranties, conditions, limitations, and notices. TI is not responsible or liable for such altered documentation. Information of third parties may be subject to additional restrictions.

Resale of TI components or services with statements different from or beyond the parameters stated by TI for that component or service voids all express and any implied warranties for the associated TI component or service and is an unfair and deceptive business practice. TI is not responsible or liable for any such statements.

Buyer acknowledges and agrees that it is solely responsible for compliance with all legal, regulatory and safety-related requirements concerning its products, and any use of TI components in its applications, notwithstanding any applications-related information or support that may be provided by TI. Buyer represents and agrees that it has all the necessary expertise to create and implement safeguards which anticipate dangerous consequences of failures, monitor failures and their consequences, lessen the likelihood of failures that might cause harm and take appropriate remedial actions. Buyer will fully indemnify TI and its representatives against any damages arising out of the use of any TI components in safety-critical applications.

In some cases, TI components may be promoted specifically to facilitate safety-related applications. With such components, TI's goal is to help enable customers to design and create their own end-product solutions that meet applicable functional safety standards and requirements. Nonetheless, such components are subject to these terms.

No TI components are authorized for use in FDA Class III (or similar life-critical medical equipment) unless authorized officers of the parties have executed a special agreement specifically governing such use.

Only those TI components which TI has specifically designated as military grade or "enhanced plastic" are designed and intended for use in military/aerospace applications or environments. Buyer acknowledges and agrees that any military or aerospace use of TI components which have **not** been so designated is solely at the Buyer's risk, and that Buyer is solely responsible for compliance with all legal and regulatory requirements in connection with such use.

TI has specifically designated certain components as meeting ISO/TS16949 requirements, mainly for automotive use. In any case of use of non-designated products, TI will not be responsible for any failure to meet ISO/TS16949.

Products

Audio	www.ti.com/audio
Amplifiers	amplifier.ti.com
Data Converters	dataconverter.ti.com
DLP® Products	www.dlp.com
DSP	dsp.ti.com
Clocks and Timers	www.ti.com/clocks
Interface	interface.ti.com
Logic	logic.ti.com
Power Mgmt	power.ti.com
Microcontrollers	microcontroller.ti.com
RFID	www.ti-rfid.com
OMAP Applications Processors	www.ti.com/omap
Wireless Connectivity	www.ti.com/wirelessconnectivity

Applications

Automotive and Transportation	www.ti.com/automotive
Communications and Telecom	www.ti.com/communications
Computers and Peripherals	www.ti.com/computers
Consumer Electronics	www.ti.com/consumer-apps
Energy and Lighting	www.ti.com/energy
Industrial	www.ti.com/industrial
Medical	www.ti.com/medical
Security	www.ti.com/security
Space, Avionics and Defense	www.ti.com/space-avionics-defense
Video and Imaging	www.ti.com/video

TI E2E Community

e2e.ti.com