

FEATURES

SPI interface with error detection

Includes CRC, invalid read/write address, and SCLK count error detection

Supports burst mode and daisy-chain mode

Industry-standard SPI Mode 0 and SPI Mode 3 interface compatible

Round robin mode allows switching times comparable with a parallel interface

General-purpose digital outputs to control other devices, such as parallel switches from Analog Devices, Inc.

4 Ω typical on-resistance at 25°C

0.5 Ω typical on-resistance flatness at 25°C

0.2 Ω typical on-resistance match between channels at 25°C

V_{SS} to V_{DD} analog signal range

Fully specified at ± 15 V, ± 5 V, and +12 V

Power-up sequence of V_{DD} , V_{SS} , and GND before applying V_L and digital/analog inputs

1.8 V logic compatibility with 2.7 V $\leq V_L \leq 3.3$ V

24-lead LFCSP package

APPLICATIONS

Automated test equipment

Data acquisition systems

Battery-powered systems

Sample-and-hold systems

Audio signal routing

Video signal routing

Communications systems

Relay replacement

GENERAL DESCRIPTION

The ADGS1408/ADGS1409 are analog multiplexers comprising eight single channels and four differential channels, respectively. A serial peripheral interface (SPI) controls the switches. The SPI interface has robust error detection features such as cyclic redundancy check (CRC) error detection, invalid read/write address detection, and SCLK count error detection.

It is possible to daisy-chain multiple ADGS1408/ADGS1409 devices together. Daisy-chain mode enables the configuration of multiple devices with a minimal amount of digital lines. The ADGS1408/ADGS1409 can also operate in burst mode to decrease the time between SPI commands.

iCMOS construction ensures ultra low power dissipation, making the devices ideally suited for portable and battery-powered instruments.

Each switch conducts equally well in both directions when on, and each switch has an input signal range that extends to the

Rev. 0

[Document Feedback](#)

Information furnished by Analog Devices is believed to be accurate and reliable. However, no responsibility is assumed by Analog Devices for its use, nor for any infringements of patents or other rights of third parties that may result from its use. Specifications subject to change without notice. No license is granted by implication or otherwise under any patent or patent rights of Analog Devices. Trademarks and registered trademarks are the property of their respective owners.

FUNCTIONAL BLOCK DIAGRAMS

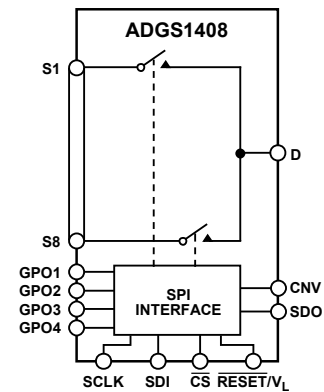

Figure 1. ADGS1408 Functional Block Diagram

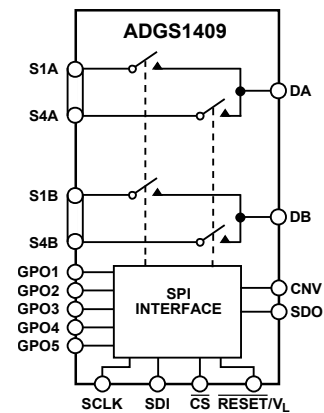

Figure 2. ADGS1409 Functional Block Diagram

supplies. In the off condition, signal levels up to the supplies are blocked.

The on-resistance profile is flat over the full analog input range, which ensures linearity and low distortion when switching audio signals.

PRODUCT HIGHLIGHTS

1. SPI interface removes the need for parallel conversion, logic traces, and reduces GPIO channel count.
2. Daisy-chain mode removes additional logic traces when multiple devices are used.
3. CRC error detection, invalid read/write address detection, and SCLK count error detection ensure a robust digital interface.
4. CRC and error detection capabilities allow the use of the ADGS1408/ADGS1409 in safety critical systems.
5. Minimal distortion.

TABLE OF CONTENTS

Features	1	Software Reset.....	24
Applications.....	1	Daisy-Chain Mode.....	24
Functional Block Diagrams.....	1	Power-On Reset.....	25
General Description.....	1	Round Robin Mode.....	26
Product Highlights	1	General-Purpose Outputs (GPOs)	27
Revision History	2	Applications Information	28
Specifications.....	3	Digital Input Buffers	28
±15 V Dual Supply	3	Power Supply Rails.....	28
±5 V Dual Supply	5	Power Supply Recommendations.....	28
12 V Single Supply.....	7	Power Supply Sequencing	28
Continuous Current per Channel, Sx or Dx.....	9	Register Summaries.....	29
Timing Characteristics	10	Register Details	30
Absolute Maximum Ratings.....	12	Switch Data Register	30
Thermal Resistance	12	Error Configuration Register.....	31
ESD Caution.....	12	Error Flags Register.....	31
Pin Configurations and Function Descriptions	13	Burst Enable Register.....	32
Typical Performance Characteristics	15	Round Robin Enable Register.....	32
Test Circuits.....	19	Round Robin Channel Configuration Register	32
Terminology	22	CNV Edge Select Register	33
Theory of Operation	23	Software Reset Register	33
Address Mode	23	Outline Dimensions	34
Error Detection Features	23	Ordering Guide	34
Clearing the Error Flags Register	24		
Burst Mode	24		

REVISION HISTORY

6/2018—Revision 0: Initial Version

SPECIFICATIONS

±15 V DUAL SUPPLY

$V_{DD} = +15\text{ V} \pm 10\%$, $V_{SS} = -15\text{ V} \pm 10\%$, $V_L = 2.7\text{ V}$ to 5.5 V , and $GND = 0\text{ V}$, unless otherwise noted.

Table 1.

Parameter	+25°C	-40°C to +85°C	-40°C to +125°C	Unit	Test Conditions/Comments
ANALOG SWITCH					
Analog Signal Range			V_{DD} to V_{SS}	V	
On Resistance, R_{ON}	4			Ω typ	$V_S = \pm 10\text{ V}$, $I_S = -10\text{ mA}$, see Figure 32
	4.7	5.7	6.7	Ω max	$V_{DD} = +13.5\text{ V}$, $V_{SS} = -13.5\text{ V}$
On-Resistance Match Between Channels, ΔR_{ON}	0.2			Ω typ	$V_S = \pm 10\text{ V}$, $I_S = -10\text{ mA}$
	0.78	0.85	1.1	Ω max	
On-Resistance Flatness, $R_{FLAT(ON)}$	0.5			Ω typ	$V_S = \pm 10\text{ V}$, $I_S = -10\text{ mA}$
	0.72	0.77	0.92	Ω max	
LEAKAGE CURRENTS					
Source Off Leakage, I_S (Off)	± 0.04			nA typ	$V_{DD} = +16.5\text{ V}$, $V_{SS} = -16.5\text{ V}$
	± 0.2	± 0.6	± 5.0	nA max	$V_S = \pm 10\text{ V}$, $V_D = 10\text{ V}$, see Figure 35
Drain Off Leakage, I_D (Off)	± 0.04			nA typ	$V_S = \pm 10\text{ V}$, $V_D = 10\text{ V}$, see Figure 35
	± 0.45	± 2.0	± 30.0	nA max	
Channel On Leakage, I_D (On), I_S (On)	± 0.1			nA typ	$V_S = V_D = \pm 10\text{ V}$, see Figure 31
	± 1.5	± 3.0	± 30.0	nA max	
DIGITAL OUTPUTS					
SDO					
Output Voltage					
Low, V_{OL}			0.4	V max	$I_{SINK} = 5\text{ mA}$
			0.2	V max	$I_{SINK} = 1\text{ mA}$
High Impedance Leakage Current	0.001			μA typ	$V_{OUT} = V_{GND}$ or V_L
			± 0.1	μA max	
High Impedance Output Capacitance	4			pF typ	
GPOx					
Output Voltage					
High, V_{OH}			$V_L - 0.2\text{ V}$	V min	$I_{SOURCE} = 100\text{ }\mu\text{A}$
Low, V_{OL}			0.2	V max	$I_{SINK} = 100\text{ }\mu\text{A}$
Timing					
t_{ON} (GPO)	95			ns typ	$C_L = 15\text{ pF}$, see Figure 43
	115	115	115	ns max	
t_{OFF} (GPO)	15			ns typ	$C_L = 15\text{ pF}$, see Figure 43
	20	25	25	ns max	
Break-Before-Make Time Delay, t_D	50			ns typ	$C_L = 15\text{ pF}$, see Figure 44
			35	ns min	
DIGITAL INPUTS					
Input Voltage					
High, V_{INH}			2	V min	$3.3\text{ V} < V_L \leq 5.5\text{ V}$
			1.35	V min	$2.7\text{ V} \leq V_L \leq 3.3\text{ V}$
Low, V_{INL}			0.8	V max	$3.3\text{ V} < V_L \leq 5.5\text{ V}$
			0.8	V max	$2.7\text{ V} \leq V_L \leq 3.3\text{ V}$
Input Current, I_{INL} or I_{INH}	0.001			μA typ	$V_{IN} = V_{GND}$ or V_L
			± 0.1	μA max	
Digital Input Capacitance, C_{IN}	4			pF typ	

Parameter	+25°C	−40°C to +85°C	−40°C to +125°C	Unit	Test Conditions/Comments	
DYNAMIC CHARACTERISTICS¹						
Transition Time, $t_{\text{TRANSITION}}$	145			ns typ	$R_L = 100 \Omega$, $C_L = 35 \text{ pF}$	
t_{ON} (EN)	185	220	245	ns max	$V_S = 10 \text{ V}$, see Figure 40	
	120			ns typ	$R_L = 100 \Omega$, $C_L = 35 \text{ pF}$	
t_{OFF} (EN)	165	185	200	ns max	$V_S = 10 \text{ V}$, see Figure 41	
	125			ns typ	$R_L = 100 \Omega$, $C_L = 35 \text{ pF}$	
Break-Before-Make Time Delay, t_D	155	175	195	ns max	$V_S = 10 \text{ V}$, see Figure 41	
	40			ns typ	$R_L = 100 \Omega$, $C_L = 35 \text{ pF}$	
Charge Injection, Q_{INJ}	−50		20	ns min	$V_{S1} = V_{S2} = 10 \text{ V}$, see Figure 39	
Off Isolation	−64			pC typ	$V_S = 0 \text{ V}$, $R_S = 0 \Omega$, $C_L = 1 \text{ nF}$, see Figure 42	
Channel to Channel Crosstalk	−70			dB typ	$R_L = 50 \Omega$, $C_L = 5 \text{ pF}$, $f = 1 \text{ MHz}$, see Figure 34	
Total Harmonic Distortion + Noise	0.025			dB typ	$R_L = 50 \Omega$, $C_L = 5 \text{ pF}$, $f = 1 \text{ MHz}$, see Figure 33	
−3 dB Bandwidth				% typ	$R_L = 110 \Omega$, 15 V p-p, $f = 20 \text{ Hz}$ to 20 kHz, see Figure 36	
	ADGS1408	60		MHz typ	$R_L = 50 \Omega$, $C_L = 5 \text{ pF}$, see Figure 37	
ADGS1409	115			MHz typ		
Insertion Loss	0.24			dB typ	$R_L = 50 \Omega$, $C_L = 5 \text{ pF}$, $f = 1 \text{ MHz}$, see Figure 26 and Figure 27	
C_S (Off)	14			pF typ	$V_S = 0 \text{ V}$, $f = 1 \text{ MHz}$	
C_D (Off)				pF typ	$V_S = 0 \text{ V}$, $f = 1 \text{ MHz}$	
	ADGS1408	80		pF typ		
ADGS1409	40			pF typ		
C_D (On), C_S (On)				pF typ	$V_S = 0 \text{ V}$, $f = 1 \text{ MHz}$	
	ADGS1408	135		pF typ		
ADGS1409	90			pF typ		
POWER REQUIREMENTS						
I_{DD}	0.002			μA typ	$V_{\text{DD}} = +16.5 \text{ V}$, $V_{\text{SS}} = -16.5 \text{ V}$	
			1	μA max	All switches open	
	220		380	μA typ	S8/S4A closed, $V_L = 5.5 \text{ V}$	
	270		440	μA max	S8/S4A closed, $V_L = 2.7 \text{ V}$	
I_L				μA typ	Digital inputs = 0 V or V_L	
	Inactive	6.3	8.0	μA max		
	Inactive, SCLK = 1 MHz	14			μA typ	$\overline{\text{CS}} = V_L$ and SDI = 0 V or V_L , $V_L = 5 \text{ V}$
		7			μA typ	$\overline{\text{CS}} = V_L$ and SDI = 0 V or V_L , $V_L = 3 \text{ V}$
	SCLK = 50 MHz	390			μA typ	$\overline{\text{CS}} = V_L$ and SDI = 0 V or V_L , $V_L = 5 \text{ V}$
		210			μA typ	$\overline{\text{CS}} = V_L$ and SDI = 0 V or V_L , $V_L = 3 \text{ V}$
	Inactive, SDI = 1 MHz	15			μA typ	$\overline{\text{CS}}$ and SCLK = 0 V or V_L , $V_L = 5 \text{ V}$
		7.5			μA typ	$\overline{\text{CS}}$ and SCLK = 0 V or V_L , $V_L = 3 \text{ V}$
	SDI = 25 MHz	230			μA typ	$\overline{\text{CS}}$ and SCLK = 0 V or V_L , $V_L = 5 \text{ V}$
		120			μA typ	$\overline{\text{CS}}$ and SCLK = 0 V or V_L , $V_L = 3 \text{ V}$
Active at 50 MHz	1.8			mA typ	Digital inputs toggle between 0 V and V_L , $V_L = 5.5 \text{ V}$	
			2.1	mA max	Digital inputs toggle between 0 V and V_L , $V_L = 2.7 \text{ V}$	
	0.7			mA typ		
			1.0	mA max		

Parameter	+25°C	-40°C to +85°C	-40°C to +125°C	Unit	Test Conditions/Comments
I_{SS}	0.002		1	$\mu\text{A typ}$ $\mu\text{A max}$	Digital inputs = 0 V or V_L
V_{DD}/V_{SS}			± 4.5 ± 16.5	V min V max	GND = 0 V GND = 0 V

¹ Guaranteed by design; not subject to production test.

±5 V DUAL SUPPLY

$V_{DD} = +5 \text{ V} \pm 10\%$, $V_{SS} = -5 \text{ V} \pm 10\%$, $V_L = 2.7 \text{ V to } 5.5 \text{ V}$, and GND = 0 V, unless otherwise noted.

Table 2.

Parameter	+25°C	-40°C to +85°C	-40°C to +125°C	Unit	Test Conditions/Comments
ANALOG SWITCH					
Analog Signal Range			V_{DD} to V_{SS}	V	
On Resistance, R_{ON}	7.4			Ω typ	$V_S = \pm 4.5 \text{ V}$, $I_S = -10 \text{ mA}$, see Figure 32
On-Resistance Match Between Channels, ΔR_{ON}	9 0.3	10.5	12	Ω max Ω typ	$V_{DD} = +4.5 \text{ V}$, $V_{SS} = -4.5 \text{ V}$ $V_S = \pm 4.5 \text{ V}$, $I_S = -10 \text{ mA}$
On-Resistance Flatness, $R_{FLAT(ON)}$	0.78 1.5 2.5	0.91 2.5	1.1 2.8	Ω max Ω typ Ω max	$V_S = \pm 4.5 \text{ V}$, $I_S = -10 \text{ mA}$
LEAKAGE CURRENTS					
Source Off Leakage, I_S (Off)	± 0.02 ± 0.2	± 0.6	± 5.0	nA typ nA max	$V_{DD} = +5.5 \text{ V}$, $V_{SS} = -5.5 \text{ V}$ $V_S = \pm 4.5 \text{ V}$, $V_D = 4.5 \text{ V}$, Figure 35
Drain Off Leakage, I_D (Off)	± 0.02			nA typ	$V_S = \pm 4.5 \text{ V}$, $V_D = 4.5 \text{ V}$, see Figure 35
Channel On Leakage, I_D (On), I_S (On)	± 0.45 ± 0.04 ± 0.3	± 0.8 ± 1.1	± 20.0 ± 22.0	nA max nA typ nA max	$V_S = V_D = \pm 4.5 \text{ V}$, see Figure 31
DIGITAL OUTPUTS					
SDO					
Output Voltage Low, V_{OL}			0.4 0.2	V max V max	$I_{SINK} = 5 \text{ mA}$ $I_{SINK} = 1 \text{ mA}$
High Impedance Leakage Current	0.001		± 0.1	$\mu\text{A typ}$ $\mu\text{A max}$	$V_{OUT} = V_{GND}$ or V_L
High Impedance Output Capacitance	4			pF typ	
GPOx					
Output Voltage High, V_{OH}			$V_L - 0.2 \text{ V}$	V min	$I_{SOURCE} = 100 \mu\text{A}$
Output Voltage Low, V_{OL}			0.2	V max	$I_{SINK} = 100 \mu\text{A}$
Timing					
t_{ON} (GPO)	95 115	115	115	ns typ ns max	$C_L = 15 \text{ pF}$, see Figure 43
t_{OFF} (GPO)	15 20	25	25	ns typ ns max	$C_L = 15 \text{ pF}$, see Figure 43
Break-Before-Make Time Delay, t_D	50		35	ns typ ns min	$C_L = 15 \text{ pF}$, see Figure 44

Parameter	+25°C	-40°C to +85°C	-40°C to +125°C	Unit	Test Conditions/Comments
DIGITAL INPUTS					
Input Voltage					
High, V_{INH}			2	V min	$3.3\text{ V} < V_L \leq 5.5\text{ V}$
Low, V_{INL}			1.35	V min	$2.7\text{ V} \leq V_L \leq 3.3\text{ V}$
Input Current, I_{INL} or I_{INH}	0.001		0.8	V max	$3.3\text{ V} < V_L \leq 5.5\text{ V}$
Digital Input Capacitance, C_{IN}	4		0.8	V max	$2.7\text{ V} \leq V_L \leq 3.3\text{ V}$
			± 0.1	$\mu\text{A typ}$	$V_{IN} = V_{GND}$ or V_L
				$\mu\text{A max}$	
				pF typ	
DYNAMIC CHARACTERISTICS¹					
Transition Time, $t_{TRANSITION}$	320			ns typ	$R_L = 100\ \Omega$, $C_L = 35\text{ pF}$
	440	515	570	ns max	$V_S = 3\text{ V}$, see Figure 40
t_{ON} (EN)	265			ns typ	$R_L = 100\ \Omega$, $C_L = 35\text{ pF}$
	365	425	470	ns max	$V_S = 3\text{ V}$, see Figure 41
t_{OFF} (EN)	245			ns typ	$R_L = 100\ \Omega$, $C_L = 35\text{ pF}$
	330	370	400	ns max	$V_S = 3\text{ V}$, see Figure 41
Break-Before-Make Time Delay, t_D	95			ns typ	$R_L = 100\ \Omega$, $C_L = 35\text{ pF}$
Charge Injection, Q_{INJ}	-10		55	ns min	$V_{S1} = V_{S2} = 3\text{ V}$, see Figure 39
Off Isolation	-64			pC typ	$V_S = 0\text{ V}$, $R_S = 0\ \Omega$, $C_L = 1\text{ nF}$, see Figure 42
Channel to Channel Crosstalk	-70			dB typ	$R_L = 50\ \Omega$, $C_L = 5\text{ pF}$, $f = 1\text{ MHz}$, see Figure 34
Total Harmonic Distortion + Noise	0.06			dB typ	$R_L = 50\ \Omega$, $C_L = 5\text{ pF}$, $f = 1\text{ MHz}$, see Figure 33
-3 dB Bandwidth				% typ	$R_L = 110\ \Omega$, 5 V p-p , $f = 20\text{ Hz}$ to 20 kHz , see Figure 36
ADGS1408	40			MHz typ	$R_L = 50\ \Omega$, $C_L = 5\text{ pF}$, see Figure 37
ADGS1409	80			MHz typ	
Insertion Loss	0.5			dB typ	$R_L = 50\ \Omega$, $C_L = 5\text{ pF}$, $f = 1\text{ MHz}$, see Figure 26 and Figure 27
C_S (Off)	20			pF typ	$V_S = 0\text{ V}$, $f = 1\text{ MHz}$
C_D (Off)				pF typ	$V_S = 0\text{ V}$, $f = 1\text{ MHz}$
ADGS1408	130			pF typ	
ADGS1409	65			pF typ	
C_D (On), C_S (On)				pF typ	$V_S = 0\text{ V}$, $f = 1\text{ MHz}$
ADGS1408	180			pF typ	
ADGS1409	120			pF typ	
POWER REQUIREMENTS					
I_{DD}	0.002			$\mu\text{A typ}$	$V_{DD} = +5.5\text{ V}$, $V_{SS} = -5.5\text{ V}$
				$\mu\text{A max}$	Digital inputs = 0 V or V_L , $V_L = 5.5\text{ V}$
	14		1	$\mu\text{A typ}$	S8/S4A closed, $V_L = 2.7\text{ V}$
			20	$\mu\text{A max}$	

Parameter	+25°C	-40°C to +85°C	-40°C to +125°C	Unit	Test Conditions/Comments
I_L					
Inactive	6.3		8.0	$\mu\text{A typ}$ $\mu\text{A max}$	Digital inputs = 0 V or V_L
Inactive, SCLK = 1 MHz	14			$\mu\text{A typ}$	$\overline{\text{CS}} = V_L$ and SDI = 0 V or V_L , $V_L = 5\text{ V}$
	7			$\mu\text{A typ}$	$\overline{\text{CS}} = V_L$ and SDI = 0 V or V_L , $V_L = 3\text{ V}$
SCLK = 50 MHz	390			$\mu\text{A typ}$	$\overline{\text{CS}} = V_L$ and SDI = 0 V or V_L , $V_L = 5\text{ V}$
	210			$\mu\text{A typ}$	$\overline{\text{CS}} = V_L$ and SDI = 0 V or V_L , $V_L = 3\text{ V}$
Inactive, SDI = 1 MHz	15			$\mu\text{A typ}$	$\overline{\text{CS}}$ and SCLK = 0 V or V_L , $V_L = 5\text{ V}$
	7.5			$\mu\text{A typ}$	$\overline{\text{CS}}$ and SCLK = 0 V or V_L , $V_L = 3\text{ V}$
SDI = 25 MHz	230			$\mu\text{A typ}$	$\overline{\text{CS}}$ and SCLK = 0 V or V_L , $V_L = 5\text{ V}$
	120			$\mu\text{A typ}$	$\overline{\text{CS}}$ and SCLK = 0 V or V_L , $V_L = 3\text{ V}$
Active at 50 MHz	1.8			mA typ	Digital inputs toggle between 0 V and V_L , $V_L = 5.5\text{ V}$
			2.1	mA max	
	0.7			mA typ	Digital inputs toggle between 0 V and V_L , $V_L = 2.7\text{ V}$
			1.0	mA max	
I_{SS}	0.002			$\mu\text{A typ}$	Digital inputs = 0 V or V_L
			1.0	$\mu\text{A max}$	
V_{DD}/V_{SS}			± 4.5	V min	GND = 0 V
			± 16.5	V max	GND = 0 V

¹ Guaranteed by design; not subject to production test.

12 V SINGLE SUPPLY

$V_{DD} = 12\text{ V} \pm 10\%$, $V_{SS} = 0\text{ V}$, $V_L = 2.7\text{ V}$ to 5.5 V , and GND = 0 V, unless otherwise noted.

Table 3.

Parameter	+25°C	-40°C to +85°C	-40°C to +125°C	Unit	Test Conditions/Comments
ANALOG SWITCH					
Analog Signal Range			0 V to V_{DD}	V	
On Resistance, R_{ON}	6.7			Ω typ	$V_S = 0\text{ V}$ to 10 V , $I_S = -10\text{ mA}$, see Figure 32
	8.7	10.2	11.7	Ω max	$V_{DD} = 10.8\text{ V}$, $V_{SS} = 0\text{ V}$
On-Resistance Match Between Channels, ΔR_{ON}	0.2			Ω typ	$V_S = 0\text{ V}$ to 10 V , $I_S = -10\text{ mA}$
	0.82	0.85	1.1	Ω max	
On-Resistance Flatness, $R_{FLAT(ON)}$	1.5			Ω typ	$V_S = 0\text{ V}$ to 10 V , $I_S = -10\text{ mA}$
	2.5	2.5	2.8	Ω max	
LEAKAGE CURRENTS					
Source Off Leakage, I_S (Off)	± 0.04			nA typ	$V_{DD} = 13.2\text{ V}$, $V_{SS} = 0\text{ V}$ $V_S = 1\text{ V}/10\text{ V}$, $V_D = 10\text{ V}/1\text{ V}$, see Figure 35
	± 0.2	± 0.6	± 5.0	nA max	
Drain Off Leakage, I_D (Off)	± 0.04			nA typ	$V_S = 1\text{ V}/10\text{ V}$, $V_D = 10\text{ V}/1\text{ V}$, see Figure 35
	± 0.45	± 1.0	± 37.0	nA max	
Channel On Leakage, I_D (On), I_S (On)	± 0.06			nA typ	$V_S = V_D = 1\text{ V}/10\text{ V}$, see Figure 31
	± 0.44	± 1.3	± 32.0	nA max	

Parameter	+25°C	−40°C to +85°C	−40°C to +125°C	Unit	Test Conditions/Comments
DIGITAL OUTPUTS					
SDO					
Output Voltage Low, V_{OL}			0.4 0.2	V max V max	$I_{SINK} = 5\text{ mA}$ $I_{SINK} = 1\text{ mA}$
High Impedance Leakage Current	0.001		± 0.1	$\mu\text{A typ}$ $\mu\text{A max}$	$V_{OUT} = V_{GND}$ or V_L
High Impedance Output Capacitance	4			pF typ	
GPOx					
Output Voltage High, V_{OH} Low, V_{OL}			$V_L - 0.2\text{ V}$ 0.2	V min V max	$I_{SOURCE} = 100\ \mu\text{A}$ $I_{SINK} = 100\ \mu\text{A}$
Timing					
t_{ON} (GPO)	95 115	115	115	ns typ ns max	$C_L = 15\text{ pF}$, see Figure 43
t_{OFF} (GPO)	15 20	25	25	ns typ ns max	$C_L = 15\text{ pF}$, see Figure 43
Break-Before-Make Time Delay, t_D	50		35	ns typ ns min	$C_L = 15\text{ pF}$, see Figure 44
DIGITAL INPUTS					
Input Voltage					
High, V_{INH}			2 1.35	V min V min	$3.3\text{ V} < V_L \leq 5.5\text{ V}$ $2.7\text{ V} \leq V_L \leq 3.3\text{ V}$
Low, V_{INL}			0.8 0.8	V max V max	$3.3\text{ V} < V_L \leq 5.5\text{ V}$ $2.7\text{ V} \leq V_L \leq 3.3\text{ V}$
Input Current, I_{INL} or I_{INH}	0.001		± 0.1	$\mu\text{A typ}$ $\mu\text{A max}$	$V_{IN} = V_{GND}$ or V_L
Digital Input Capacitance, C_{IN}	4			pF typ	
DYNAMIC CHARACTERISTICS¹					
Transition Time, $t_{TRANSITION}$	210 280	340	385	ns typ ns max	$R_L = 100\ \Omega$, $C_L = 35\text{ pF}$ $V_S = 8\text{ V}$, see Figure 40
t_{ON} (EN)	195 250	295	325	ns typ ns max	$R_L = 100\ \Omega$, $C_L = 35\text{ pF}$ $V_S = 8\text{ V}$, see Figure 41
t_{OFF} (EN)	145 185	215	240	ns typ ns max	$R_L = 100\ \Omega$, $C_L = 35\text{ pF}$ $V_S = 8\text{ V}$, see Figure 41
Break-Before-Make Time Delay, t_D	90		50	ns typ ns min	$R_L = 100\ \Omega$, $C_L = 35\text{ pF}$ $V_{S1} = V_{S2} = 8\text{ V}$, see Figure 39
Charge Injection, Q_{INJ}	−12			pC typ	$V_S = 6\text{ V}$, $R_S = 0\ \Omega$, $C_L = 1\text{ nF}$, see Figure 42
Off Isolation	−64			dB typ	$R_L = 50\ \Omega$, $C_L = 5\text{ pF}$, $f = 1\text{ MHz}$, see Figure 34
Channel to Channel Crosstalk	−70			dB typ	$R_L = 50\ \Omega$, $C_L = 5\text{ pF}$, $f = 1\text{ MHz}$, see Figure 33
−3 dB Bandwidth					$R_L = 50\ \Omega$, $C_L = 5\text{ pF}$, see Figure 37
ADGS1408	36			MHz typ	
ADGS1409	72			MHz typ	
Insertion Loss	0.5			dB typ	$R_L = 50\ \Omega$, $C_L = 5\text{ pF}$, $f = 1\text{ MHz}$, see Figure 26 and Figure 27
C_S (Off)	20			pF typ	$V_S = 6\text{ V}$, $f = 1\text{ MHz}$
C_D (Off)					$V_S = 6\text{ V}$, $f = 1\text{ MHz}$
ADGS1408	120			pF typ	
ADGS1409	60			pF typ	

Parameter	+25°C	−40°C to +85°C	−40°C to +125°C	Unit	Test Conditions/Comments
C_D (On), C_S (On)					$V_S = 6\text{ V}$, $f = 1\text{ MHz}$
ADGS1408	170			pF typ	
ADGS1409	110			pF typ	
POWER REQUIREMENTS					
I_{DD}	0.002		1	$\mu\text{A typ}$ $\mu\text{A max}$	$V_{DD} = 13.2\text{ V}$ All switches open
	220		380	$\mu\text{A typ}$ $\mu\text{A max}$	S8/S4A closed, $V_L = 5.5\text{ V}$
	270		440	$\mu\text{A typ}$ $\mu\text{A max}$	S8/S4A closed, $V_L = 2.7\text{ V}$
I_L					
Inactive	6.3		8.0	$\mu\text{A typ}$ $\mu\text{A max}$	Digital inputs = 0 V or V_L
Inactive, SCLK = 1 MHz	14			$\mu\text{A typ}$	$\overline{CS} = V_L$ and SDI = 0 V or V_L , $V_L = 5\text{ V}$
	7			$\mu\text{A typ}$	$\overline{CS} = V_L$ and SDI = 0 V or V_L , $V_L = 3\text{ V}$
SCLK = 50 MHz	390			$\mu\text{A typ}$	$\overline{CS} = V_L$ and SDI = 0 V or V_L , $V_L = 5\text{ V}$
	210			$\mu\text{A typ}$	$\overline{CS} = V_L$ and SDI = 0 V or V_L , $V_L = 3\text{ V}$
Inactive, SDI = 1 MHz	15			$\mu\text{A typ}$	\overline{CS} and SCLK = 0 V or V_L , $V_L = 5\text{ V}$
	7.5			$\mu\text{A typ}$	\overline{CS} and SCLK = 0 V or V_L , $V_L = 3\text{ V}$
SDI = 25 MHz	230			$\mu\text{A typ}$	\overline{CS} and SCLK = 0 V or V_L , $V_L = 5\text{ V}$
	120			$\mu\text{A typ}$	\overline{CS} and SCLK = 0 V or V_L , $V_L = 3\text{ V}$
Active at 50 MHz	1.8			mA typ	Digital inputs toggle between 0 V and V_L , $V_L = 5.5\text{ V}$
	0.7		2.1	mA max mA typ	Digital inputs toggle between 0 V and V_L , $V_L = 2.7\text{ V}$
V_{DD}			1.0	mA max	
			5	V min	GND = 0 V, $V_{SS} = 0\text{ V}$
			20	V max	GND = 0 V, $V_{SS} = 0\text{ V}$

¹ Guaranteed by design; not subject to production test.

CONTINUOUS CURRENT PER CHANNEL, Sx OR Dx

Table 4. ADGS1408, One Channel On

Parameter	25°C	85°C	125°C	Unit
CONTINUOUS CURRENT, Sx OR Dx ¹				
$V_{DD} = 15\text{ V}$, $V_{SS} = -15\text{ V}$ ($\theta_{JA} = 58.4^\circ\text{C/W}$)	304.9	133.6	48.9	mA max
$V_{DD} = 12\text{ V}$, $V_{SS} = 0\text{ V}$ ($\theta_{JA} = 58.4^\circ\text{C/W}$)	259.7	122.7	48	mA max
$V_{DD} = 5\text{ V}$, $V_{SS} = -5\text{ V}$ ($\theta_{JA} = 58.4^\circ\text{C/W}$)	247.2	119.3	47.6	mA max

¹ Sx refers to the S1 to S8 pins.

Table 5. ADGS1409, Two Channels On

Parameter	25°C	85°C	125°C	Unit
CONTINUOUS CURRENT, Sx OR Dx ¹				
$V_{DD} = 15\text{ V}$, $V_{SS} = -15\text{ V}$ ($\theta_{JA} = 58.4^\circ\text{C/W}$)	229.6	114.3	47.2	mA max
$V_{DD} = 12\text{ V}$, $V_{SS} = 0\text{ V}$ ($\theta_{JA} = 58.4^\circ\text{C/W}$)	194.7	103	45.7	mA max
$V_{DD} = 5\text{ V}$, $V_{SS} = -5\text{ V}$ ($\theta_{JA} = 58.4^\circ\text{C/W}$)	185.2	99.6	45.2	mA max

¹ Sx refers to the S1A to S4A and S1B to S4B pins, and Dx refers to the DA and DB pins.

TIMING CHARACTERISTICS

$V_L = 2.7\text{ V}$ to 5.5 V , $GND = 0\text{ V}$, and all specifications T_{MIN} to T_{MAX} , unless otherwise noted. Guaranteed by design and characterization, not production tested.

Table 6.

Parameter	Limit	Unit	Test Conditions/Comments
TIMING CHARACTERISTICS			
t_1	20	ns min	SCLK or CNV period
t_2	8	ns min	SCLK or CNV high pulse width
t_3	8	ns min	SCLK or CNV low pulse width
t_4	10	ns min	\overline{CS} falling edge to SCLK or CNV active edge
t_5	6	ns min	Data setup time
t_6	8	ns min	Data hold time
t_7	10	ns min	SCLK or CNV active edge to \overline{CS} rising edge
t_8	20	ns max	\overline{CS} falling edge to SDO data available
t_9^1	20	ns max	SCLK falling edge to SDO data available
t_{10}	20	ns max	\overline{CS} rising edge to SDO returns to high impedance
t_{11}	20	ns min	\overline{CS} high time between SPI commands
t_{12}	8	ns min	\overline{CS} falling edge to SCLK/CNV becomes stable
t_{13}	8	ns min	\overline{CS} rising edge to SCLK/CNV becomes stable

¹ Measured with the 1 kΩ pull-up resistor to V_L and 20 pF load. t_9 determines the maximum SCLK frequency when SDO is used.

Timing Diagrams

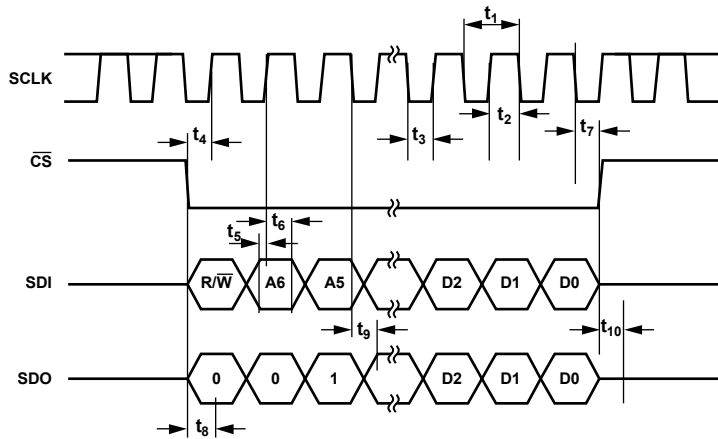

Figure 3. Address Mode Timing Diagram

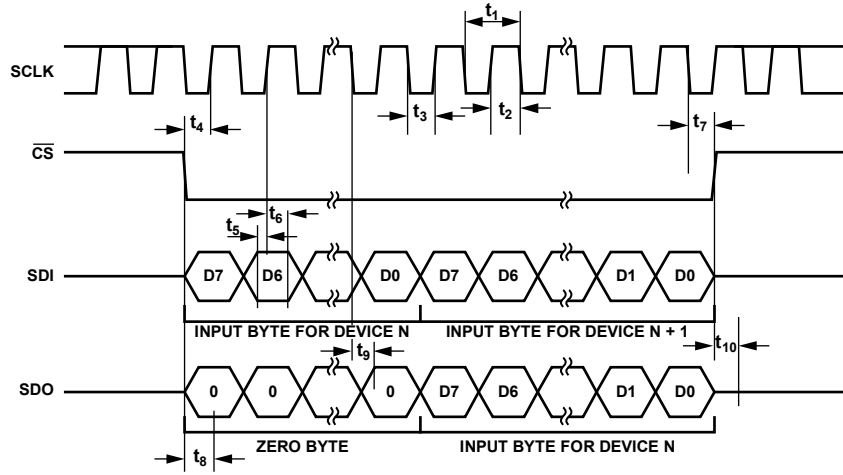

Figure 4. Daisy-Chain Timing Diagram

16791-103

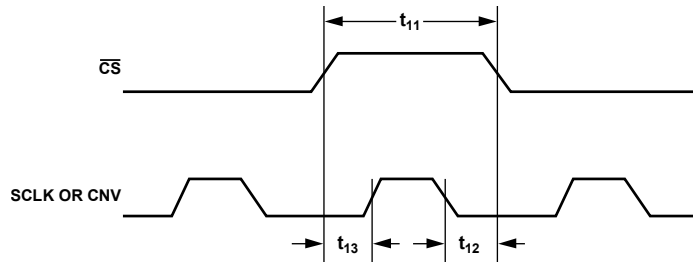

Figure 5. SCLK or CNV and CS Timing Relationship

16791-004

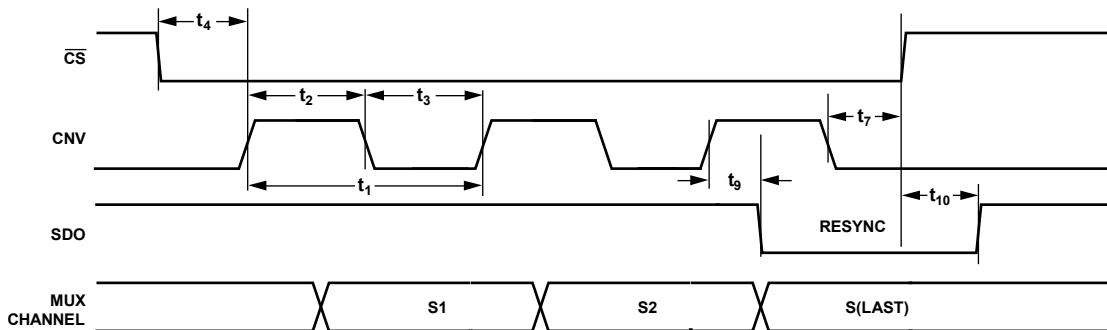

Figure 6. Round Robin Timing Diagram

16791-005

ABSOLUTE MAXIMUM RATINGS

$T_A = 25^\circ\text{C}$, unless otherwise noted.

Table 7.

Parameter	Rating
V_{DD} to V_{SS}	35 V
V_{DD} to GND	-0.3 V to +25 V
V_{SS} to GND	+0.3 V to -25 V
V_L to GND	
For $V_{DD} \leq 5.5\text{V}$	-0.3 V to $V_{DD} + 0.3\text{V}$
For $V_{DD} > 5.5\text{V}$	-0.3 V to +6 V
SDO	-0.3 V to +6 V
GPOx	-0.3 V to $V_L + 0.3\text{V}$
Analog Inputs ¹	$V_{SS} - 0.3\text{V}$ to $V_{DD} + 0.3\text{V}$ or 30 mA, whichever occurs first
Digital Inputs ¹	-0.3 V to +6 V
Peak Current, Sx or Dx Pins ²	497 mA (pulsed at 1 ms, 10% duty cycle maximum)
Continuous Current, Sx or Dx ^{2,3}	Data + 15%
Operating Temperature Range	-40°C to +125°C
Storage Temperature Range	-65°C to +150°C
Junction Temperature	150°C
Reflow Soldering Peak Temperature, Pb-Free	260(+0/-5)°C

¹ Overvoltages at the digital Sx and Dx pins are clamped by internal diodes. Limit current to the maximum ratings given.

² Sx refers to the S1 to S4 pins, and Dx refers to the D1 to D4 pins.

³ See Table 4 and Table 5.

Stresses at or above those listed under Absolute Maximum Ratings may cause permanent damage to the product. This is a stress rating only; functional operation of the product at these or any other conditions above those indicated in the operational section of this specification is not implied. Operation beyond the maximum operating conditions for extended periods may affect product reliability.

Only one absolute maximum rating can be applied at any one time.

THERMAL RESISTANCE

Thermal performance is directly linked to printed circuit board (PCB) design and operating environment. Close attention to PCB thermal design is required.

Table 8. Thermal Resistance

Package Type	θ_{JA}	θ_{JCB} ¹	Ψ_{JT}	Unit
CP-24-17 ²	58.4	17.2	2.2	°C/W

¹ θ_{JCB} is the junction to the bottom of the case value.

² Thermal impedance simulated values are based on a JEDEC 252P thermal test board with four thermal vias. See JEDEC JESD51.

ESD CAUTION



ESD (electrostatic discharge) sensitive device. Charged devices and circuit boards can discharge without detection. Although this product features patented or proprietary protection circuitry, damage may occur on devices subjected to high energy ESD. Therefore, proper ESD precautions should be taken to avoid performance degradation or loss of functionality.

PIN CONFIGURATIONS AND FUNCTION DESCRIPTIONS

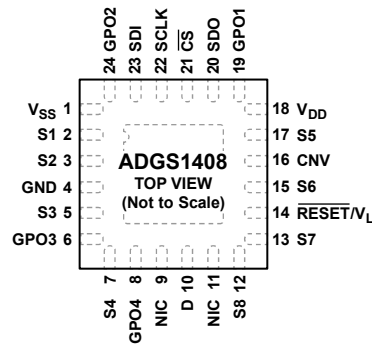

- NOTES**
1. THE EXPOSED PAD IS CONNECTED INTERNALLY. FOR INCREASED RELIABILITY OF THE SOLDER JOINTS AND MAXIMUM THERMAL CAPABILITY, IT IS RECOMMENDED THAT THE EXPOSED PAD BE SOLDERED TO THE SUBSTRATE, V_{SS}.
 2. NIC = NOT INTERNALLY CONNECTED.

Figure 7. ADGS1408 Pin Configuration

Table 9. ADGS1408 Pin Function Descriptions

Pin No.	Mnemonic	Description
1	V _{SS}	Most Negative Power Supply Potential. In single-supply applications, tie this pin to ground.
2	S1	Source Terminal 1. This pin can be an input or output.
3	S2	Source Terminal 2. This pin can be an input or output.
4	GND	Ground (0 V) Reference.
5	S3	Source Terminal 3. This pin can be an input or output.
6	GPO3	General-Purpose Output 3. This pin is a digital output.
7	S4	Source Terminal 4. This pin can be an input or output.
8	GPO4	General-Purpose Output 4. This pin is a digital output.
9, 11	NIC	Not Internally Connected.
10	D	Drain Terminal. This pin can be an input or output.
12	S8	Source Terminal 8. This pin can be an input or output.
13	S7	Source Terminal 7. This pin can be an input or output.
14	RESET/V _L	RESET/Logic Power Supply Input (V _L). Under normal operation, drive the RESET/V _L pin with a 2.7 V to 5.5 V supply. Pull the RESET/V _L pin low to complete a hardware reset. After a reset, all switches open, and the appropriate registers are set to their default.
15	S6	Source Terminal 6. This pin can be an input or output.
16	CNV	Convert Digital Input. When in round robin mode, the CNV pin is used to cycle through the selected channels.
17	S5	Source Terminal 5. This pin can be an input or output.
18	V _{DD}	Most Positive Power Supply Potential.
19	GPO1	General-Purpose Output 1. This pin is a digital output.
20	SDO	Serial Data Output. This pin can be used for daisy chaining a number of these devices together or for reading back the data stored in a register for diagnostic purposes. The serial data is propagated on the falling edge of SCLK. Pull this open-drain output to V _L with an external resistor.
21	\overline{CS}	Active Low Control Input. \overline{CS} is the frame synchronization signal for the input data.
22	SCLK	Serial Clock Input. Data is captured on the positive edge of SCLK. Data can be transferred at rates of up to 50 MHz.
23	SDI	Serial Data Input. Data is captured on the positive edge of the serial clock input.
24	GPO2 EPAD	General-Purpose Output 2. This pin is a digital output. Exposed Pad. The exposed pad is connected internally. For increased reliability of the solder joints and maximum thermal capability, it is recommended that the exposed pad be soldered to the substrate, V _{SS} .

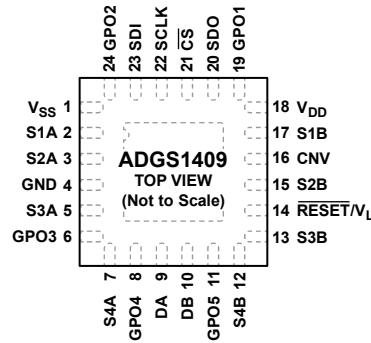

NOTES
 1. THE EXPOSED PAD IS CONNECTED INTERNALLY. FOR INCREASED RELIABILITY OF THE SOLDER JOINTS AND MAXIMUM THERMAL CAPABILITY, IT IS RECOMMENDED THAT THE EXPOSED PAD BE SOLDERED TO THE SUBSTRATE, V_{SS}.

16791-008

Figure 8. ADGS1409 Pin Configuration

Table 10. ADGS1409 Pin Function Descriptions

Pin No.	Mnemonic	Description
1	V _{SS}	Most Negative Power Supply Potential. In single-supply applications, tie this pin to ground.
2	S1A	Source Terminal 1A. This pin can be an input or output.
3	S2A	Source Terminal 2A. This pin can be an input or output.
4	GND	Ground (0 V) Reference.
5	S3A	Source Terminal 3A. This pin can be an input or output.
6	GPO3	General-Purpose Output 3. This pin is a digital output.
7	S4A	Source Terminal 4A. This pin can be an input or output.
8	GPO4	General-Purpose Output 4. This pin is a digital output.
9	DA	Drain Terminal A. This pin can be an input or output.
10	DB	Drain Terminal B. This pin can be an input or output.
11	GPO5	General-Purpose Output 5. This pin is a digital output.
12	S4B	Source Terminal 4B. This pin can be an input or output.
13	S3B	Source Terminal 3B. This pin can be an input or output.
14	RESET/V _L	RESET/Logic Power Supply Input (V _L). Under normal operation, drive the RESET/V _L pin with a 2.7 V to 5.5 V supply. Pull the RESET/V _L pin low to complete a hardware reset. After a reset, all switches open, and the appropriate registers are set to their default.
15	S2B	Source Terminal 2B. This pin can be an input or output.
16	CNV	Convert Digital Input. When in round robin mode, the CNV pin is used to cycle through the selected channels.
17	S1B	Source Terminal 1B. This pin can be an input or output.
18	V _{DD}	Most Positive Power Supply Potential.
19	GPO1	General-Purpose Output 1. This pin is a digital output.
20	SDO	Serial Data Output. This pin can be used for daisy chaining a number of these devices together or for reading back the data stored in a register for diagnostic purposes. The serial data is propagated on the falling edge of SCLK. Pull this open-drain output to V _L with an external resistor.
21	\overline{CS}	Active Low Control Input. \overline{CS} is the frame synchronization signal for the input data.
22	SCLK	Serial Clock Input. Data is captured on the positive edge of SCLK. Data can be transferred at rates of up to 50 MHz.
23	SDI	Serial Data Input. Data is captured on the positive edge of the serial clock input.
24	GPO2 EPAD	General-Purpose Output 2. This pin is a digital output. Exposed Pad. The exposed pad is connected internally. For increased reliability of the solder joints and maximum thermal capability, it is recommended that the exposed pad be soldered to the substrate, V _{SS} .

TYPICAL PERFORMANCE CHARACTERISTICS

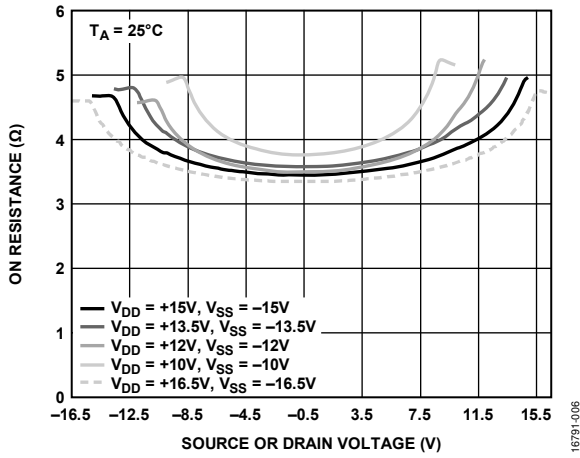

Figure 9. On Resistance vs. V_S or V_D for Various Dual Supplies

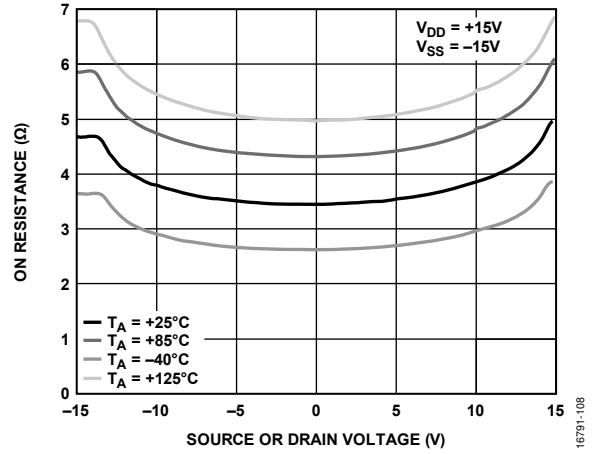

Figure 12. On Resistance vs. V_S or V_D for Various Temperatures, $\pm 15\text{ V}$ Dual Supply

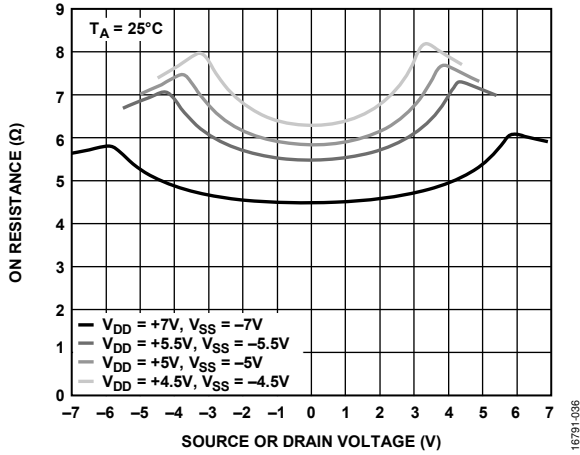

Figure 10. On Resistance vs. V_S or V_D for Various Dual Supplies

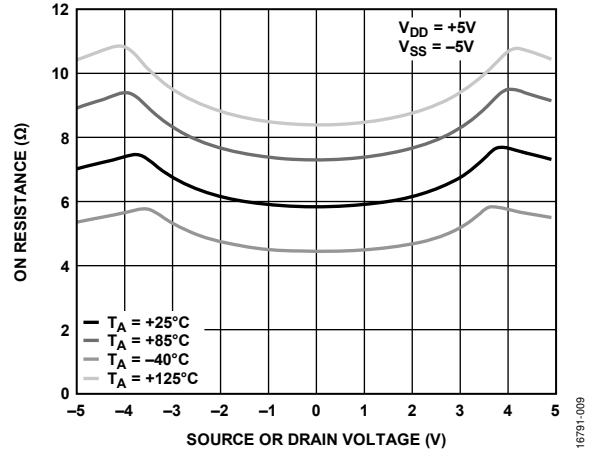

Figure 13. On Resistance vs. V_S or V_D for Various Temperatures, $\pm 5\text{ V}$ Dual Supply

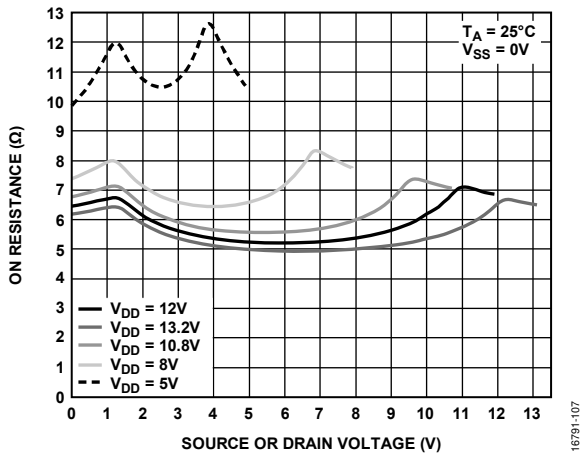

Figure 11. On Resistance vs. V_S or V_D for Various Single Supplies

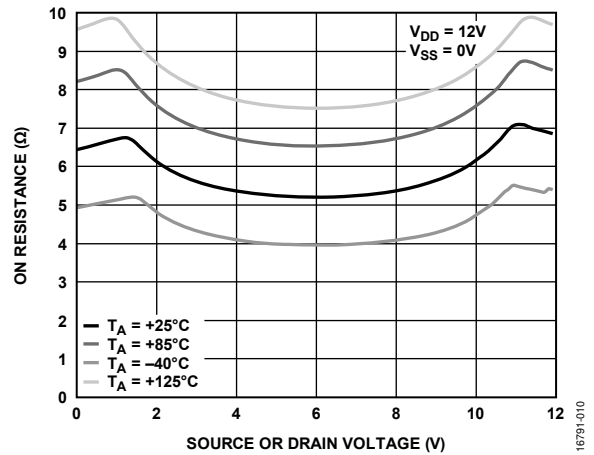

Figure 14. On Resistance vs. V_S or V_D for Various Temperatures, 12 V Single Supply

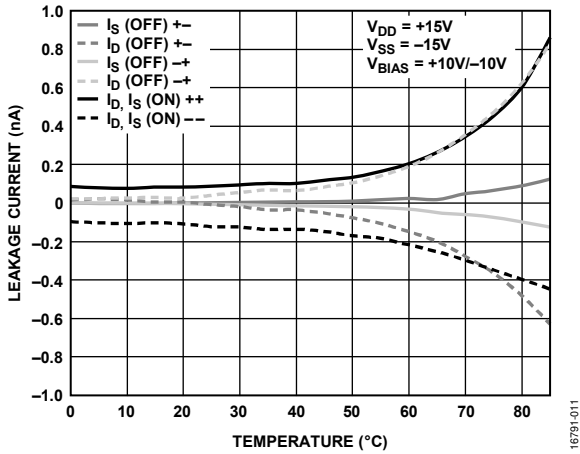

Figure 15. Leakage Current vs. Temperature, ±15 V Dual Supply

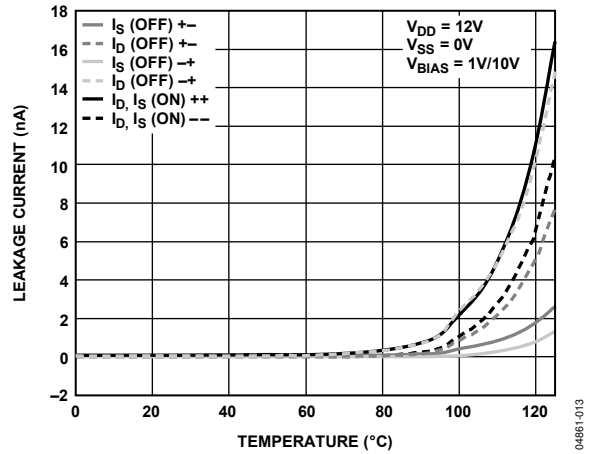

Figure 18. Leakage Current vs. Temperature, 12 V Single Supply

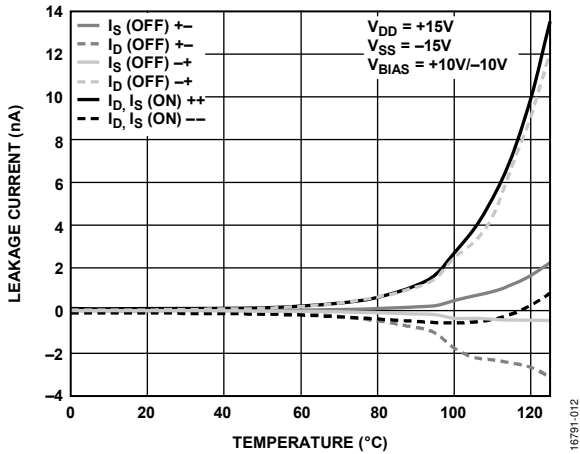

Figure 16. Leakage Current vs. Temperature, ±15 V Dual Supply

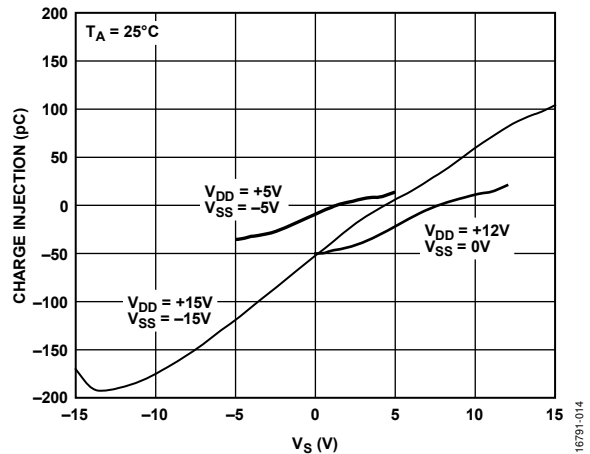

Figure 19. Charge Injection vs. Source Voltage (V_S)

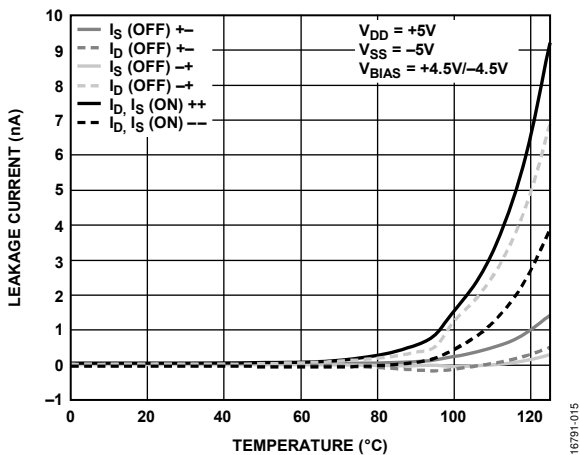

Figure 17. Leakage Current vs. Temperature, ±5 V Dual Supply

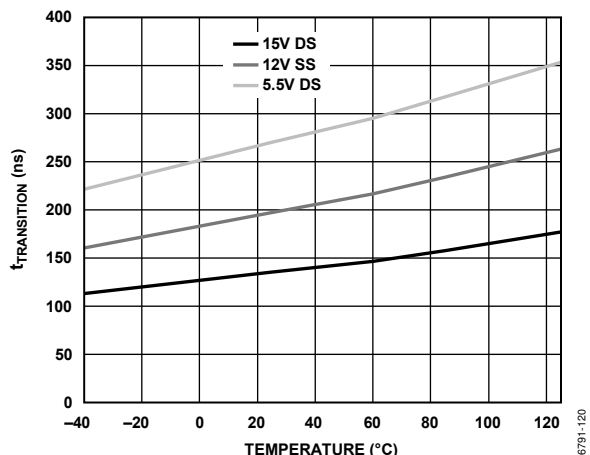

Figure 20. Transition Time vs. Temperature for Single Supply (SS) and Dual Supply (DS)

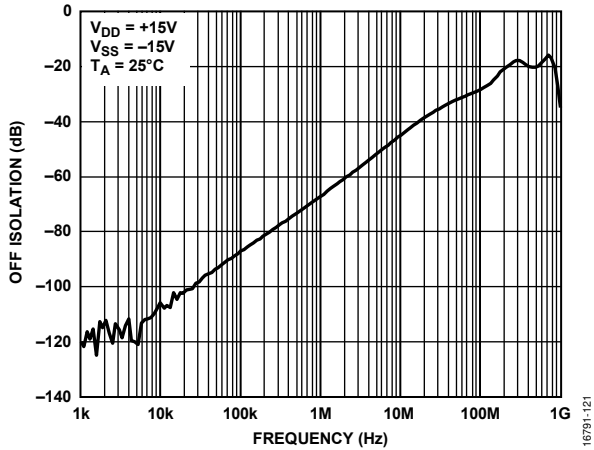

Figure 21. Off Isolation vs. Frequency, ±15 V Dual Supply

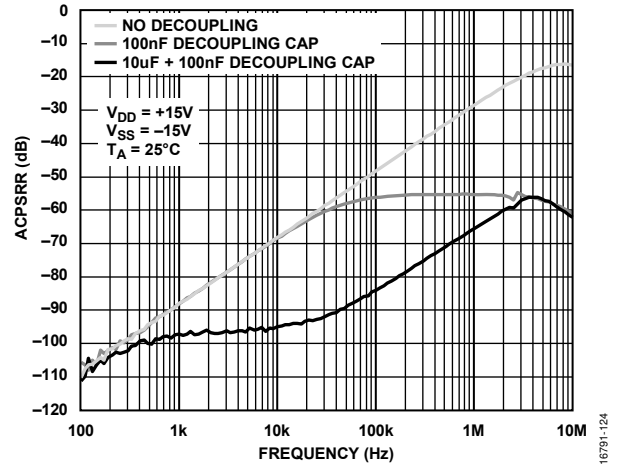

Figure 24. AC Power Supply Rejection Ratio (ACPSRR) vs. Frequency, ±15 V Dual Supply

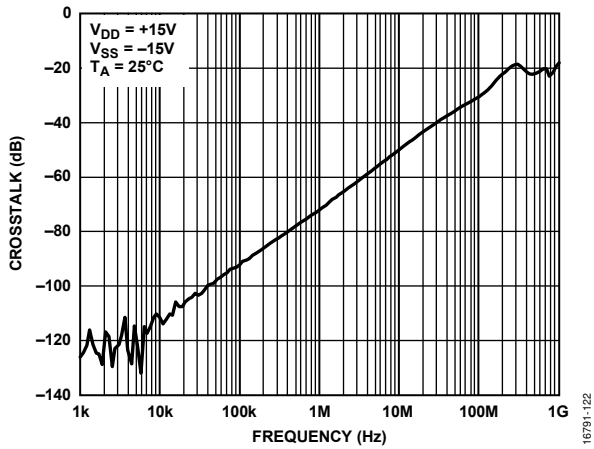

Figure 22. ADGS1408 Crosstalk vs. Frequency, ±15 V Dual Supply

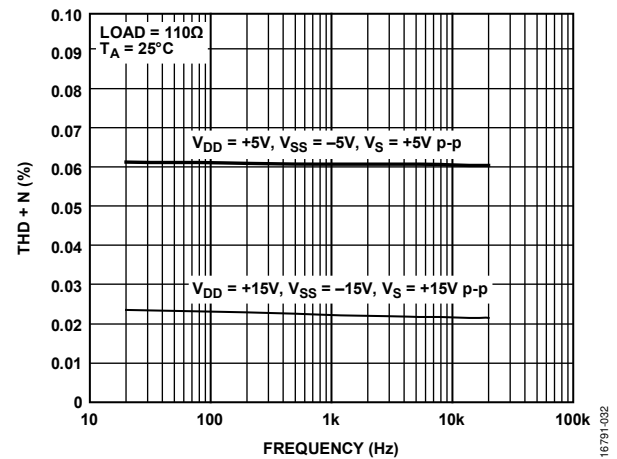

Figure 25. THD + N vs. Frequency

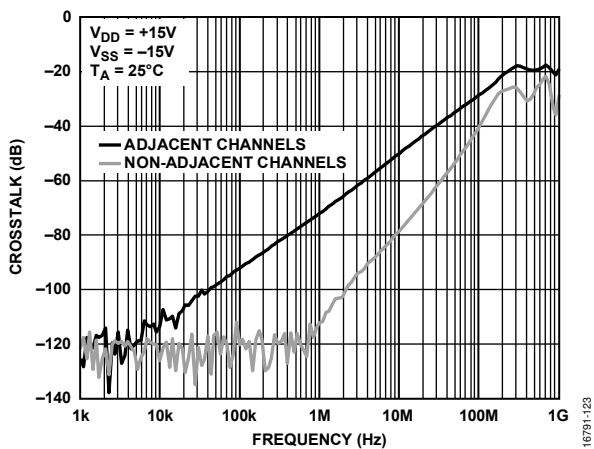

Figure 23. ADGS1409 Crosstalk vs. Frequency, ±15 V Dual Supply

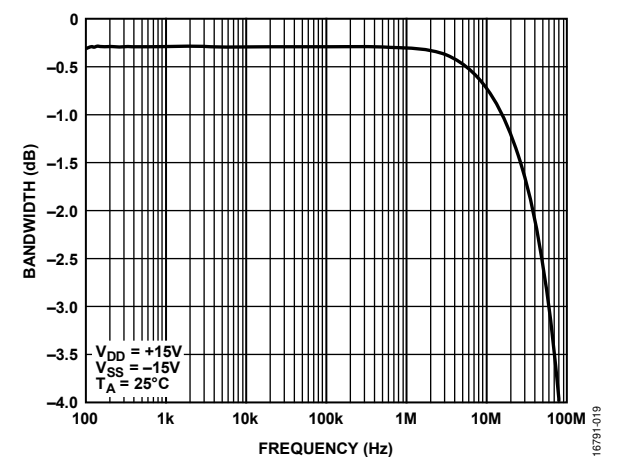

Figure 26. ADGS1408 Insertion Loss vs. Frequency, ±15 V Dual Supply

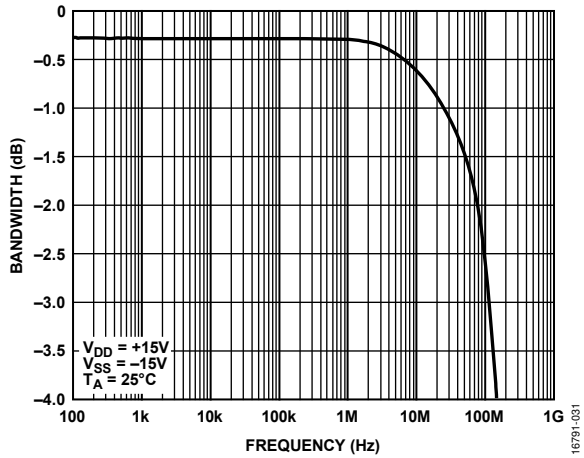

Figure 27. ADGS1409 Insertion Loss vs. Frequency, ±15 V Dual Supply

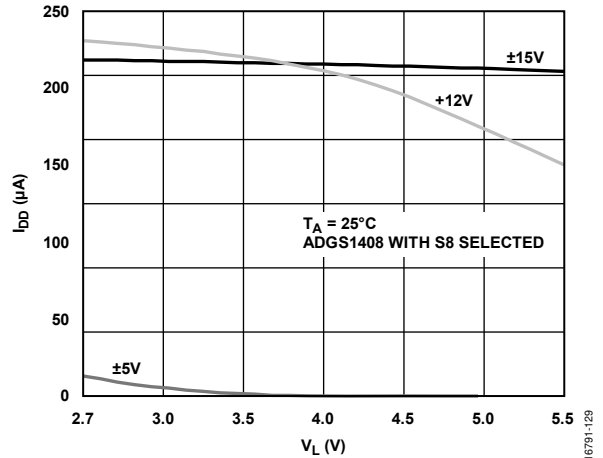

Figure 29. I_{DD} vs. V_L

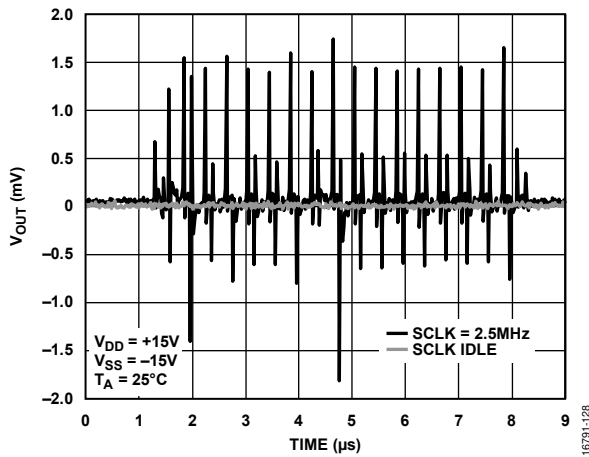

Figure 28. Digital Feedthrough

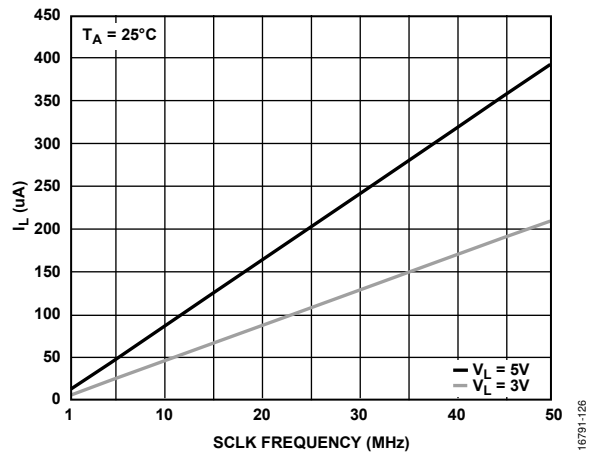

Figure 30. I_L vs. SCLK Frequency when \overline{CS} is High

TEST CIRCUITS

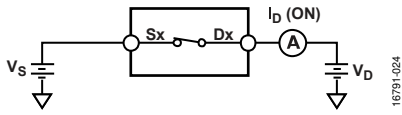

Figure 31. On Leakage

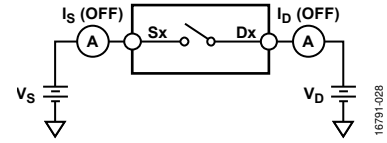

Figure 35. Off Leakage

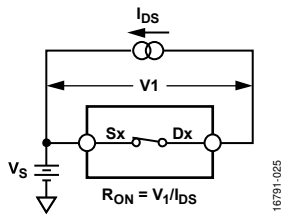

Figure 32. On Resistance

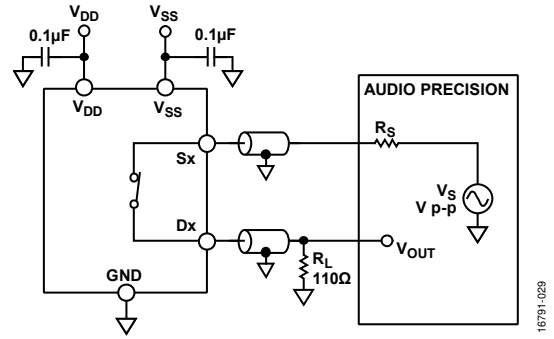
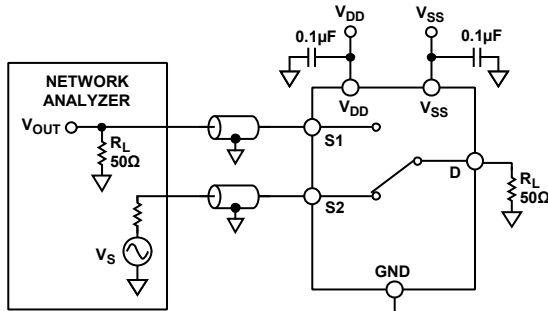
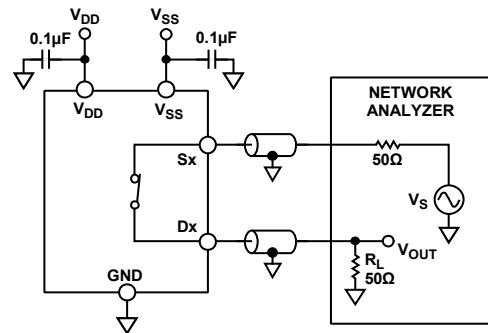

Figure 36. THD + Noise



CHANNEL TO CHANNEL CROSSTALK = $20 \log \frac{V_{OUT}}{V_S}$

Figure 33. Channel to Channel Crosstalk



INSERTION LOSS = $20 \log \frac{V_{OUT \text{ WITH SWITCH}}}{V_S \text{ WITHOUT SWITCH}}$

Figure 37. -3 dB Bandwidth

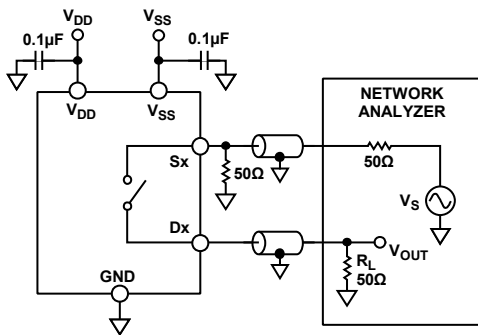

OFF ISOLATION = $20 \log \frac{V_{OUT}}{V_S}$

Figure 34. Off Isolation

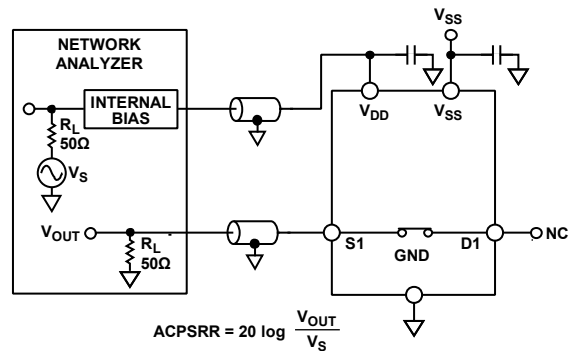

ACPSRR = $20 \log \frac{V_{OUT}}{V_S}$

Figure 38. ACPSRR

NOTES
1. BOARD AND COMPONENT EFFECTS ARE NOT DE-EMBEDDED FROM THE ACPSRR MEASUREMENT.

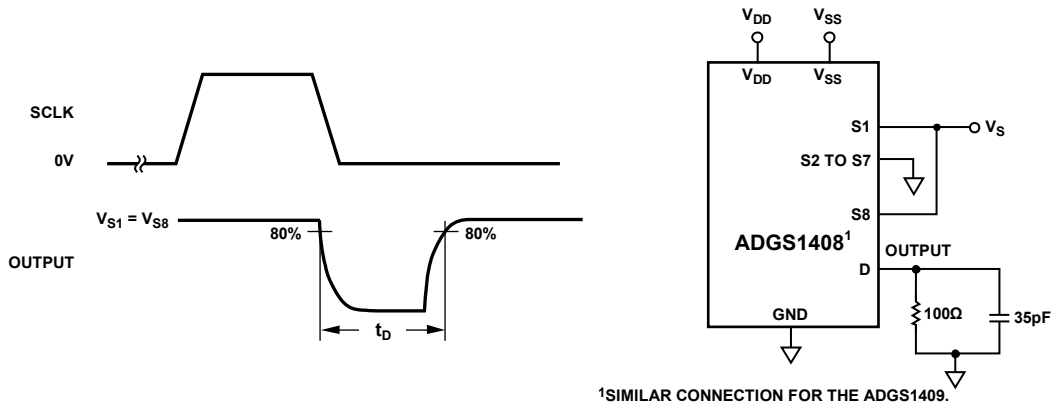

Figure 39. Break-Before-Make Time Delay, t_D

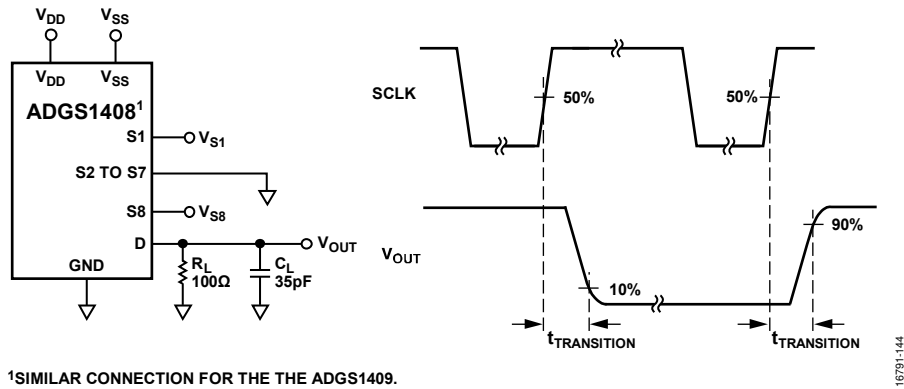

Figure 40. Transition Time, $t_{TRANSITION}$

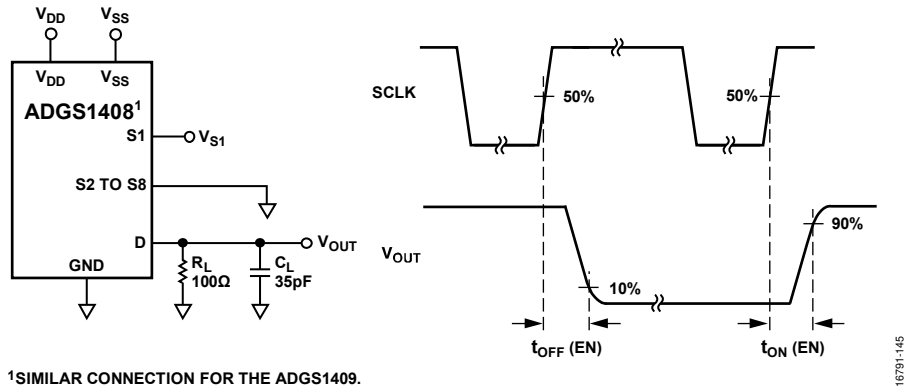

Figure 41. Switching Times, $t_{ON(EN)}$ and $t_{OFF(EN)}$

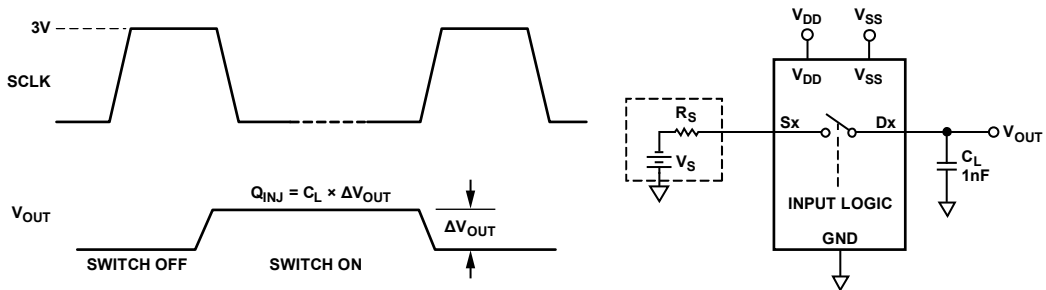
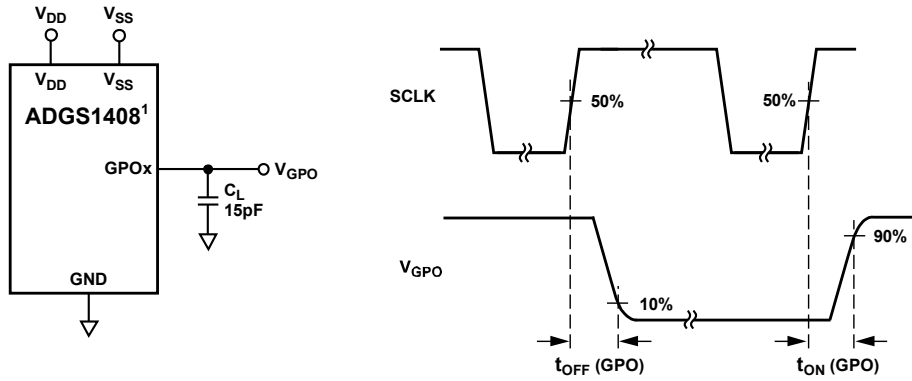

Figure 42. Charge Injection, Q_{INU}



¹SIMILAR CONNECTION FOR THE ADGS1409.

Figure 43. GPOx Timing, $t_{ON}(GPO)$ and $t_{OFF}(GPO)$

16791-146

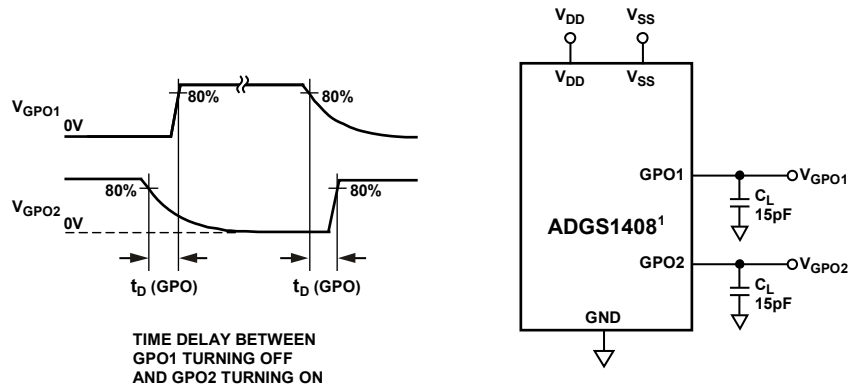

TIME DELAY BETWEEN
GPO1 TURNING OFF
AND GPO2 TURNING ON

¹SIMILAR CONNECTION FOR THE ADGS1409.

Figure 44. GPOx Break-Before-Make Time Delay, $t_D(GPO)$

16791-147

TERMINOLOGY

I_{DD}

I_{DD} is the positive supply current.

I_{SS}

I_{SS} is the negative supply current.

V_D, V_S

V_D and V_S are the analog voltages on Terminal Dx and Terminal Sx, respectively.

R_{ON}

R_{ON} is the ohmic resistance between Terminal Dx and Terminal Sx.

ΔR_{ON}

ΔR_{ON} is the difference between the R_{ON} of any two channels.

$R_{FLAT(ON)}$

$R_{FLAT(ON)}$ is flatness defined as the difference between the maximum and minimum value of on resistance values measured over the specified analog signal range.

I_S (Off)

I_S (off) is the source leakage current with the switch off.

I_D (Off)

I_D (off) is the drain leakage current with the switch off.

I_S (On), I_D (On)

I_S (on) and I_D (on) are the channel leakage currents with the switch on.

V_{INL}

V_{INL} is the maximum input voltage for Logic 0.

V_{INH}

V_{INH} is the minimum input voltage for Logic 1.

I_{INL}, I_{INH}

I_{INL} and I_{INH} are the low and high input currents of the digital inputs.

C_D (Off)

C_D (off) is the off switch drain capacitance, which is measured with reference to ground.

C_S (Off)

C_S (off) is the off switch source capacitance, which is measured with reference to ground.

C_D (On), C_S (On)

C_D (on) and C_S (on) are the on switch capacitances, which are measured with reference to ground.

C_{IN}

C_{IN} is the digital input capacitance.

t_{ON}

t_{ON} is the delay between applying the digital control input and the output switching on.

t_{OFF}

t_{OFF} is the delay between applying the digital control input and the output switching off.

Off Isolation

Off isolation is a measure of unwanted signal coupling through an off switch.

Charge Injection

Charge injection is a measure of the glitch impulse transferred from the digital input to the analog output during switching.

Crosstalk

Crosstalk is a measure of unwanted signal that is coupled through from one channel to another as a result of parasitic capacitance.

-3 dB Bandwidth

Bandwidth is the frequency at which the output is attenuated by 3 dB.

On Response

On response is the frequency response of the on switch.

Insertion Loss

Insertion loss is the loss due to the on resistance of the switch.

Total Harmonic Distortion + Noise (THD + N)

THD + N is the ratio of the harmonic amplitude plus noise of the signal to the fundamental.

AC Power Supply Rejection Ratio (ACPSRR)

ACPSRR is the ratio of the amplitude of signal on the output to the amplitude of the modulation. ACPSRR is a measure of the ability of the devices to avoid coupling noise and spurious signals that appear on the supply voltage pin to the output of the switch. The dc voltage on the device is modulated by a sine wave of 0.62 V p-p.

THEORY OF OPERATION

The ADGS1408/ADGS1409 are a set of serially controlled analog multiplexers comprising eight single channels and four differential channels, respectively, with error detection features. SPI Mode 0 and SPI Mode 3 can be used with the devices. The devices operate with SCLK frequencies up to 50 MHz. The default mode for the ADGS1408/ADGS1409 is address mode, in which the registers of the device are accessed by a 16-bit SPI command bounded by \overline{CS} . The SPI command becomes 24-bit if the user enables CRC error detection. Other error detection features include SCLK count error and invalid read/write error. If any of these SPI interface errors occur, they are detectable by reading the error flags register. The ADGS1408/ADGS1409 can also operate in two other modes, namely burst mode and daisy-chain mode.

The interface pins of the ADGS1408/ADGS1409 are \overline{CS} , SCLK, SDI, and SDO. Hold \overline{CS} low when using the SPI interface. Data is captured on SDI on the rising edge of SCLK, and data is propagated out on SDO on the falling edge of SCLK. SDO has an open-drain output. Connect a pull-up to this output. When not pulled low by the ADGS1408/ADGS1409, SDO is in a high impedance state.

ADDRESS MODE

Address mode is the default mode for the ADGS1408/ADGS1409 on power-up. A single SPI frame in address mode is bounded by a \overline{CS} falling edge and the succeeding \overline{CS} rising edge. An SPI frame is comprised of 16 SCLK cycles. The timing diagram for address mode is shown in Figure 45. The first SDI bit indicates if the SPI command is a read or write command. When the first bit is set to 0, a write command is issued, and if the first bit is set to 1, a read command is issued. The next seven bits determine the target register address. The remaining eight bits provide the data to the addressed register. The last eight bits are ignored during a read command, because during these clock cycles, SDO propagates out the data contained in the addressed register.

The target register address of an SPI command is determined on the eighth SCLK rising edge. Data from this register propagates out on SDO from the 9th to the 16th SCLK falling edge during SPI reads. A register write occurs on the 16th SCLK rising edge during SPI writes.

During any SPI command, SDO sends out eight alignment bits on the first eight SCLK falling edges. The alignment bits observed at SDO are 0x25.

ERROR DETECTION FEATURES

Protocol and communication errors on the SPI interface are detectable. There are three detectable errors: incorrect SCLK error detection, invalid read and write address error detection, and CRC error detection. Each error has a corresponding enable bit in the error configuration register. In addition, there is an error flag bit for each error in the error flags register.

CRC Error Detection

The CRC error detection feature extends a valid SPI frame by eight SCLK cycles. These eight extra cycles are needed to send the CRC byte for that SPI frame. The CRC byte is calculated by the SPI block using the 16-bit payload: the R/W bit, Register Address Bits[6:0], and Register Data Bits[7:0]. The CRC polynomial used in the SPI block is $x^8 + x^2 + x^1 + 1$ with a seed value of 0. For a timing diagram with CRC enabled, see Figure 46. Register writes occur at the 24th SCLK rising edge with CRC error checking enabled.

During an SPI write, the microcontroller/CPU provides the CRC byte through SDI. The SPI block checks the CRC byte just before the 24th SCLK rising edge. On this same edge, the register write is prevented if an incorrect CRC byte is received by the SPI interface. In the case of the incorrect CRC byte being detected, the CRC error flag is asserted in the error flags register.

During an SPI read, the CRC byte is provided to the microcontroller through SDO.

The CRC error detection feature is disabled by default and can be configured by the user through the error configuration register.

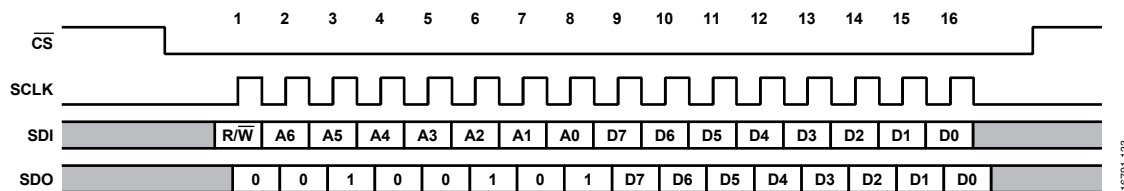

Figure 45. Address Mode Timing Diagram

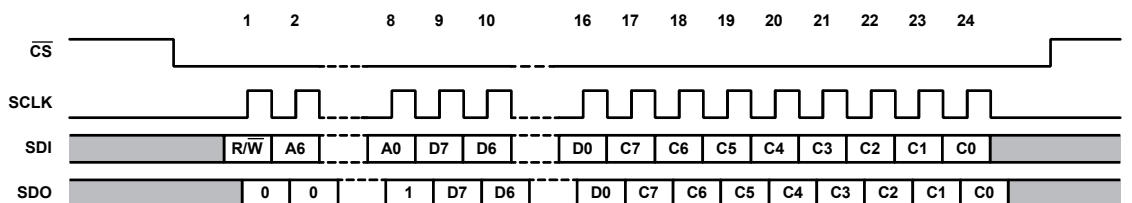

Figure 46. Timing Diagram with CRC Enabled

SCLK Count Error Detection

SCLK count error detection allows the user to detect if an incorrect number of SCLK cycles are sent by the microcontroller/CPU. When in address mode, with CRC disabled, 16 SCLK cycles are expected. If 16 SCLK cycles are not detected, the SCLK count error flag asserts in the error flags register. When fewer than 16 SCLK cycles are received by the device, a write to the register map never occurs. When the ADGS1408/ADGS1409 receive more than 16 SCLK cycles, a write to the memory map still occurs at the 16th SCLK rising edge, and the flag asserts in the error flags register. With CRC enabled, the expected number of SCLK cycles is 24. SCLK count error detection is enabled by default and can be configured by the user through the error configuration register.

Invalid Read/Write Address Error Detection

An invalid read/write address error detects when a nonexistent register address is a target for a read or write. In addition, this error asserts when a write to a read only register is attempted. The invalid read/write address error flag asserts in the error flags register when an invalid read/write address error occurs. The invalid read/write address error is detected on the ninth SCLK rising edge, which means a write to the register never occurs when an invalid address is targeted. Invalid read/write address error detection is enabled by default and can be disabled by the user through the error configuration register.

CLEARING THE ERROR FLAGS REGISTER

To clear the error flags register, write the special 16-bit SPI frame, 0x6CA9, to the device. This SPI command does not trigger the invalid read/write address error. When CRC is enabled, the user must also send the correct CRC byte for a successful error clear command. At the 16th or 24th SCLK rising edge, the error flags register resets to 0.

BURST MODE

The SPI interface can accept consecutive SPI commands without the need to deassert the \overline{CS} line, which is called burst mode. Burst mode is enabled through the burst enable register. This mode uses the same 16-bit command to communicate with the device. In addition, the response of the device at SDO is still aligned with the corresponding SPI command. Figure 47 shows an example of SDI and SDO during burst mode.

The invalid read/write address and CRC error checking functions operate similarly during burst mode as they do during address mode. However, SCLK count error detection operates in a slightly different manner. The total number of SCLK cycles within a given \overline{CS} frame are counted, and if the total is not a multiple of 16, or a multiple of 24 when CRC is enabled, the SCLK count error flag asserts.

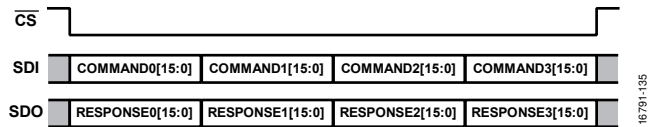

Figure 47. Burst Mode Frame

SOFTWARE RESET

When in address mode, the user can initiate a software reset. To initiate a software reset, write two consecutive SPI commands, namely 0xA3 followed by 0x05, targeting Register 0x0B. After a software reset, all register values are set to default.

DAISY-CHAIN MODE

The connection of several ADGS1408/ADGS1409 devices in a daisy-chain configuration is possible, and Figure 48 shows this setup. All devices share the same \overline{CS} and SCLK line, whereas the SDO of a device forms a connection to the SDI of the next device, creating a shift register. In daisy-chain mode, SDO is an eight-cycle delayed version of SDI. When in daisy-chain mode, all commands target the switch data register. Therefore, it is not possible to make configuration changes while in daisy-chain mode.

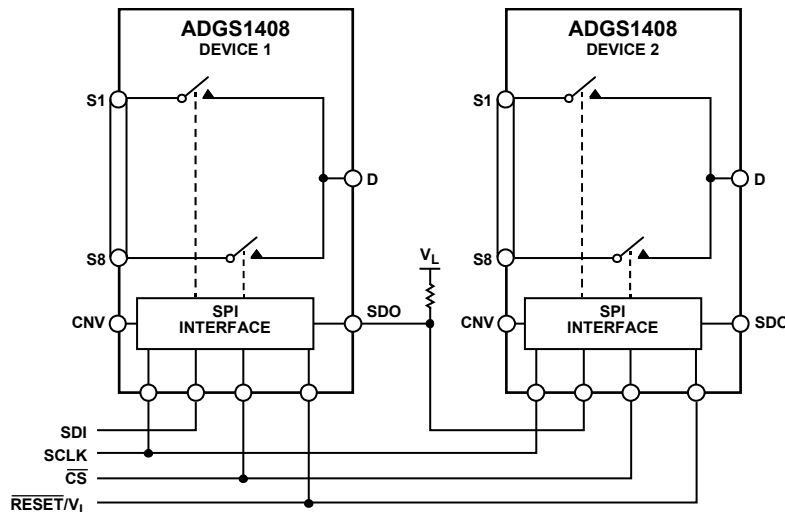

Figure 48. Two ADGS1408 Devices Connected in a Daisy-Chain Configuration

The ADGS1408/ADGS1409 can only enter daisy-chain mode when in address mode by sending the 16-bit SPI command, 0x2500 (see Figure 49). When the ADGS1408/ADGS1409 receive this command, the SDO of the device sends out the same command because the alignment bits at SDO are 0x25, which allows multiple daisy-connected devices to enter daisy-chain mode in a single SPI frame. A hardware reset is required to exit daisy-chain mode.

For the timing diagram of a typical daisy-chain SPI frame, see Figure 50. When \overline{CS} goes high, Device 1 writes Command 0, Bits[7:0] to its switch data register, Device 2 writes Command 1, Bits[7:0] to its switches, and so on. The SPI block uses the last eight bits it received through SDI to update the switches. After entering daisy-chain mode, the first eight bits sent out by SDO on each device in the chain are 0x00. When \overline{CS} goes high, the internal shift register value does not reset back to zero.

An SCLK rising edge reads in data on SDI while data is propagated out of SDO on an SCLK falling edge. The expected number of SCLK cycles must be a multiple of eight before \overline{CS} goes high. When the expected number of SCLK cycles is not a multiple of eight, the SPI interface sends the last eight bits received to the switch data register.

POWER-ON RESET

The digital section of the ADGS1408/ADGS1409 goes through an initialization phase during V_L power-up. This initialization also occurs after a hardware or software reset. After V_L power-up or a reset, ensure a minimum of 120 μs from the time of power-up or reset before any SPI command is issued. Ensure that V_L does not drop out during the 120 μs initialization phase because it may result in incorrect operation of the ADGS1408/ADGS1409.

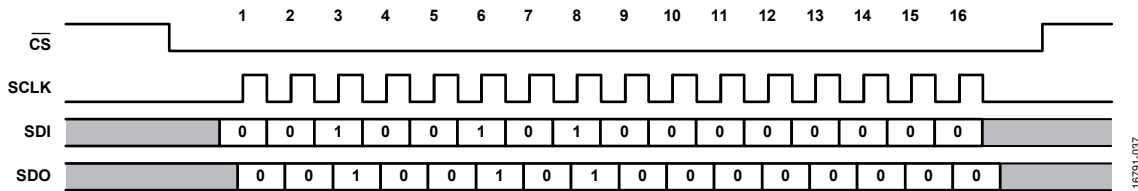
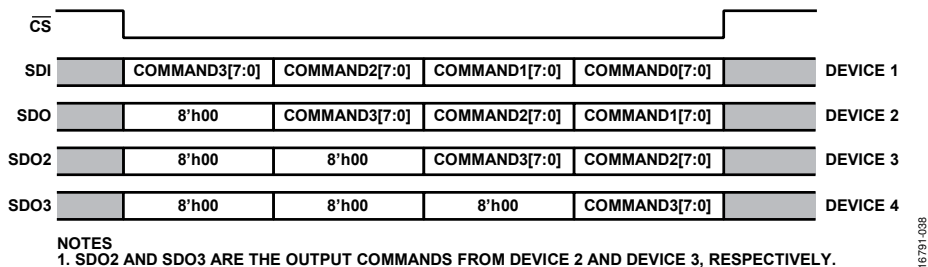

Figure 49. SPI Command to Enter Daisy-Chain Mode



NOTES
1. SDO2 AND SDO3 ARE THE OUTPUT COMMANDS FROM DEVICE 2 AND DEVICE 3, RESPECTIVELY.

Figure 50. Example of an SPI Frame Where Four ADGS1408/ADGS1409 Devices Connect in Daisy-Chain Mode

ROUND ROBIN MODE

Round robin mode allows the ADGS1408/ADGS1409 to cycle through the channels faster by reducing the overhead needed from the digital interface to switch from one channel to the next. The round robin configuration register selects which channels are to be included in a cycle, and the CNV edge select register selects on which edge of CNV the ADGS1408/ADGS1409 switch to the next channel in the sequence. At the end of the channel cycle, a resync pulse appears on SDO to inform the user that the current cycle ended; then, SDO loops back to the start of the sequence of channels. Figure 51 shows an example of the round robin mode interface, and Figure 52 shows the CNV signal of the analog-to-digital converter (ADC) being used in conjunction with the ADGS1408 in round robin mode.

After configuration completes, the round robin enable register allows the ADGS1408/ADGS1409 to enter round robin mode. When in round robin mode, the SPI is no longer used to switch between channels. Instead, to switch from one channel to another, ensure that a digital signal is present on the CNV pin while \overline{CS} is pulled low.

To exit round robin mode, either perform a hardware reset or send the following two 16-bit addressable mode SPI frames: 0xA318, followed by 0xE3B4. These frames are the only SPI commands recognized by the SPI interface while in round robin mode.

Round robin mode is significantly faster than addressable mode to cycle through channels because it removes the 16-bit overhead required to change input channel. In addition, round robin mode removes the need for SCLK to be running, which reduces the digital current consumption, I_L . The maximum CNV frequency is bound by the transition time of the device along with the required settling time for the application.

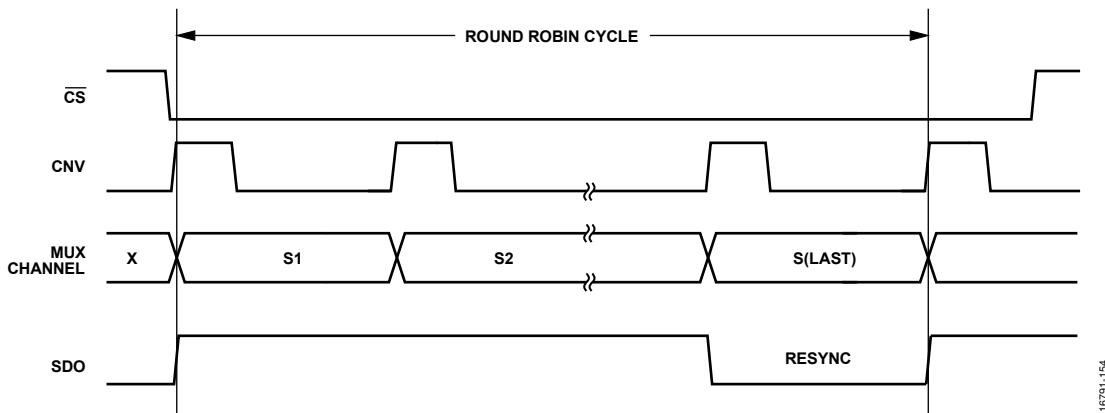

Figure 51. Round Robin Mode Interface Example

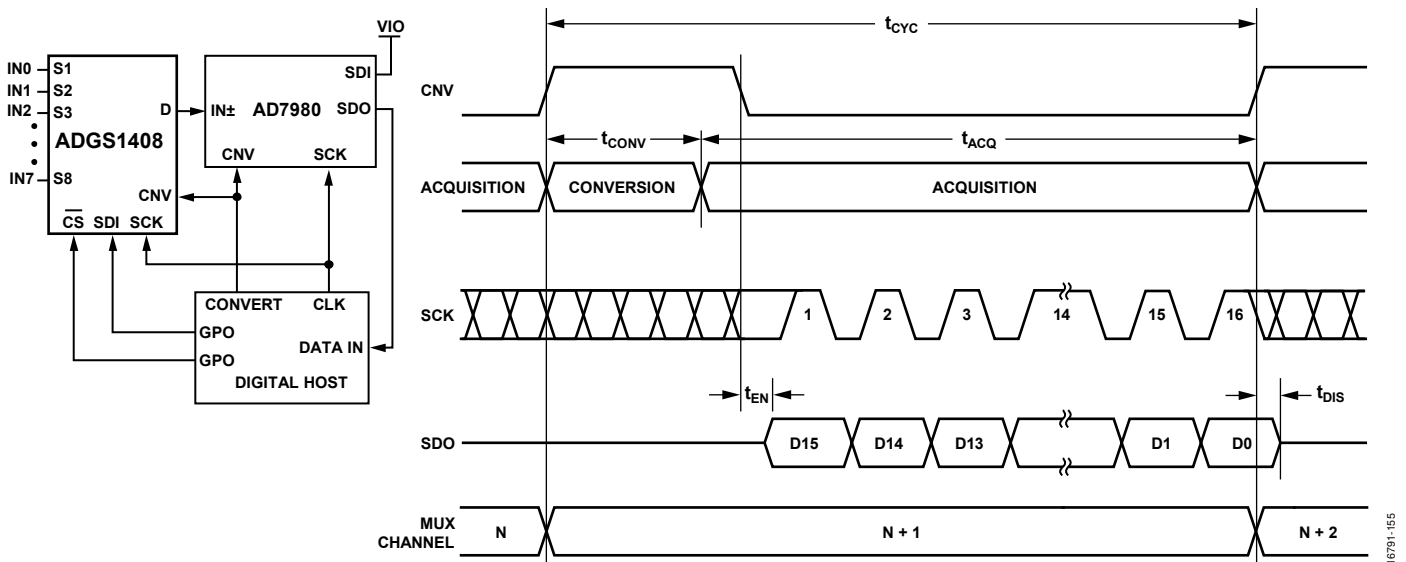

Figure 52. Example of the CNV Signal of an ADC Cycling Through Channels in the ADGS1408

GENERAL-PURPOSE OUTPUTS (GPOs)

The ADGS1408 has four GPOs, and the ADGS1409 has five GPOs. These digital outputs allow the control of other devices using the ADGS1408/ADGS1409. The GPOs are controlled from the SW_DATA register where they can be either set high

or low. When the device is in round robin mode, the GPOs are driven low. The logic low level is GND, and V_L sets the logic high level. Figure 53 shows how the ADGS1408 can be used to control another device, which in this example is the [ADG758](#).

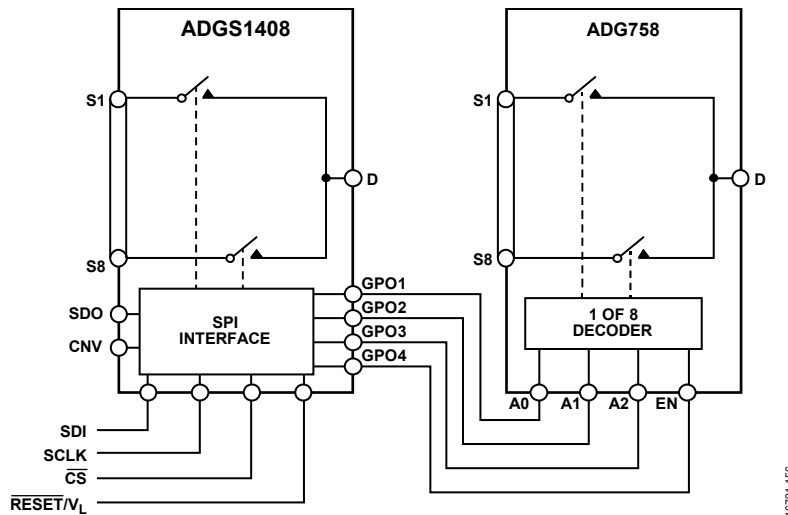

Figure 53. ADGS1408 Device Controlling the [ADG758](#)

16791-1-66

APPLICATIONS INFORMATION

DIGITAL INPUT BUFFERS

There are input buffers present on the digital input pins (\overline{CS} , SCLK, and SDI). These buffers are active at all times; as a result, there is current drawn from the V_L supply if SCLK or SDI are toggling, regardless of whether \overline{CS} is active. For typical values of this current draw, refer to the Specifications section and Figure 30.

POWER SUPPLY RAILS

To guarantee correct operation of the ADGS1408/ADGS1409, 0.1 μF decoupling capacitors are required.

The ADGS1408/ADGS1409 can operate with bipolar supplies between $\pm 4.5\text{ V}$ and $\pm 16.5\text{ V}$. The supplies on V_{DD} and V_{SS} do not need to be symmetrical; however, the V_{DD} to V_{SS} range must not exceed 33 V. The ADGS1408/ADGS1409 can also operate with single supplies between 5 V and 20 V with V_{SS} connected to GND.

The voltage range that can be supplied to V_L is from 2.7 V to 5.5 V. The device is fully specified at $\pm 15\text{ V}$, $\pm 5\text{ V}$, and $+12\text{ V}$ analog supply voltage ranges.

POWER SUPPLY RECOMMENDATIONS

Analog Devices has a wide range of power management products to meet the requirements of most high performance signal chains.

An example of a bipolar power solution is shown in Figure 54. The ADP5070 dual switching regulator generates a positive and negative supply rail for the ADGS1408/ADGS1409, an amplifier, and/or a precision converter in a typical signal chain. Also shown in Figure 54 are two optional low dropout regulators

(LDOs), ADP7118 and ADP7182 (positive and negative LDOs, respectively), that can be used to reduce the output ripple of the ADP5070 in ultralow noise sensitive applications.

The ADM7160 can be used to generate the V_L voltage required to power digital circuitry within the ADGS1408/ADGS1409.

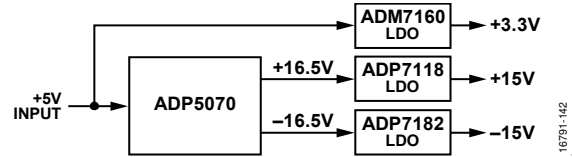

Figure 54. Bipolar Power Solution

Table 11. Recommended Power Management Devices

Product	Description
ADP5070	1 A/0.6 A, dc-to-dc switching regulator with independent positive and negative outputs
ADM7160	5.5 V, 200 mA, ultralow noise, linear regulator
ADP7118	20 V, 200 mA, low noise, CMOS LDO linear regulator
ADP7182	-28 V, -200 mA, low noise, LDO linear regulator

POWER SUPPLY SEQUENCING

Take care to ensure correct power supply sequencing. Incorrect power supply sequencing can result in the device being subjected to stresses beyond the maximum ratings listed in Table 7. Ensure that the analog power supplies (V_{DD} and V_{SS}) and ground (GND) are present before applying V_L , the digital inputs, and the analog inputs. Failure to adhere to this sequence may result in damage to the device.

REGISTER SUMMARIES

Table 12. ADGS1408 Register Summary

Reg.	Name	Bit 7	Bit 6	Bit 5	Bit 4	Bit 3	Bit 2	Bit 1	Bit 0	Default	RW
0x01	SW_DATA	GPO4	GPO3	GPO2	GPO1	A2	A1	A0	EN	0x00	R/W
0x02	ERR_CONFIG	Reserved					RW_ERR_EN	SCLK_ERR_EN	CRC_ERR_EN	0x06	R/W
0x03	ERR_FLAGS	Reserved					RW_ERR_FLAG	SCLK_ERR_FLAG	CRC_ERR_FLAG	0x00	R
0x05	BURST_EN	Reserved							BURST_MODE_EN	0x00	R/W
0x06	ROUND_ROBIN_EN	Reserved							ROUND_ROBIN_EN	0x00	R/W
0x07	RROBIN_CHANNEL_CONFIG	S8_EN	S7_EN	S6_EN	S5_EN	S4_EN	S3_EN	S2_EN	S1_EN	0xFF	R/W
0x09	CNV_EDGE_SEL	Reserved							CNV_EDGE_SEL	0x00	R/W
0x0B	SOFT_RESETB	SOFT_RESETB								0x00	R/W

Table 13. ADGS1409 Register Summary

Reg.	Name	Bit 7	Bit 6	Bit 5	Bit 4	Bit 3	Bit 2	Bit 1	Bit 0	Default	RW
0x01	SW_DATA	GPO5	GPO4	GPO3	GPO2	GPO1	A1	A0	EN	0x00	R/W
0x02	ERR_CONFIG	Reserved					RW_ERR_EN	SCLK_ERR_EN	CRC_ERR_EN	0x06	R/W
0x03	ERR_FLAGS	Reserved					RW_ERR_FLAG	SCLK_ERR_FLAG	CRC_ERR_FLAG	0x00	R
0x05	BURST_EN	Reserved							BURST_MODE_EN	0x00	R/W
0x06	ROUND_ROBIN_EN	Reserved							ROUND_ROBIN_EN	0x00	R/W
0x07	RROBIN_CHANNEL_CONFIG	Reserved				S4_EN	S3_EN	S2_EN	S1_EN	0x0F	R/W
0x09	CNV_EDGE_SEL	Reserved							CNV_EDGE_SEL	0x00	R/W
0x0B	SOFT_RESETB	SOFT_RESETB								0x00	R/W

REGISTER DETAILS

SWITCH DATA REGISTER

Address: 0x01, Reset: 0x00, Name: SW_DATA

The switch data register controls the status of the eight switches of the ADGS1408/ADGS1409, as well as the general-purpose digital outputs. Use the ADGS1408/ADGS1409 truth tables in conjunction with the bit descriptions.

Table 14. Bit Descriptions for SW_DATA, ADGS1408

Bit(s)	Bit Name	Settings	Description	Default	Access
7	GPO4		Enable bit for GPO4.	0x0	R/W
6	GPO3		Enable bit for GPO3.	0x0	R/W
5	GPO2		Enable bit for GPO2.	0x0	R/W
4	GPO1		Enable bit for GPO1.	0x0	R/W
3	A2		Enable bit for A2.	0x0	R/W
2	A1		Enable bit for A1.	0x0	R/W
1	A0		Enable bit for A0.	0x0	R/W
0	EN	0 1	Enable bit for ADGS1408. ADGS1408 disabled. ADGS1408 enabled.	0x0	R/W

Table 15. Bit Descriptions for SW_DATA, ADGS1409

Bit(s)	Bit Name	Settings	Description	Default	Access
7	GPO5		Enable bit for GPO5.	0x0	R/W
6	GPO4		Enable bit for GPO4.	0x0	R/W
5	GPO3		Enable bit for GPO3.	0x0	R/W
4	GPO2		Enable bit for GPO2.	0x0	R/W
3	GPO1		Enable bit for GPO1.	0x0	R/W
2	A1		Enable bit for A1.	0x0	R/W
1	A0		Enable bit for A0.	0x0	R/W
0	EN	0 1	Enable bit for ADGS1409. ADGS1409 disabled. ADGS1409 enabled.	0x0	R/W

Table 16. ADGS1408 Truth Table¹

A2	A1	A0	EN	On Switch
X	X	X	0	None
0	0	0	1	S1
0	0	1	1	S2
0	1	0	1	S3
0	1	1	1	S4
1	0	0	1	S5
1	0	1	1	S6
1	1	0	1	S7
1	1	1	1	S8

¹ X means don't care.

Table 17. ADGS1409 Truth Table¹

A1	A0	EN	On Switch Pair
X	X	0	None
0	0	1	S1
0	1	1	S2
1	0	1	S3
1	1	1	S4

¹ X means don't care.

ERROR CONFIGURATION REGISTER

Address: 0x02, Reset: 0x06, Name: ERR_CONFIG

The error configuration register allows the user to enable and disable the relevant error features as required.

Table 18. Bit Descriptions for ERR_CONFIG

Bit(s)	Bit Name	Settings	Description	Default	Access
[7:3]	Reserved		These bits are reserved. Set these bits to 0.	0x0	R
2	RW_ERR_EN	0 1	Enable bit for detecting an invalid read/write address. Disabled. Enabled.	0x1	R/W
1	SCLK_ERR_EN	0 1	Enable bit for detecting the correct number of SCLK cycles in an SPI frame. 16 SCLK cycles are expected when CRC is disabled and burst mode is disabled. 24 SCLK cycles are expected when CRC is enabled and burst mode is disabled. A multiple of 16 SCLK cycles is expected when CRC is disabled and burst mode is enabled. A multiple of 24 SCLK cycles is expected when CRC is enabled and burst mode is enabled.	0x1	R/W
0	CRC_ERR_EN	0 1	Enable bit for CRC error detection. SPI frames are 24 bits wide when enabled. Disabled. Enabled.	0x0	R/W

ERROR FLAGS REGISTER

Address: 0x03, Reset: 0x00, Name: ERR_FLAGS

The error flags register allows the user to determine if an error occurred. To clear the error flags register, write the special 16-bit SPI command, 0x6CA9, to the device. This SPI command does not trigger the invalid R/W address error. When CRC is enabled, the user must include the correct CRC byte during the SPI write for the clear error flags register command to succeed.

Table 19. Bit Descriptions for ERR_FLAGS

Bit(s)	Bit Name	Settings	Description	Default	Access
[7:3]	Reserved		These bits are reserved. Set these bits to 0.	0x0	R
2	RW_ERR_FLAG	0 1	Error flag for invalid read/write address. The error flag asserts during an SPI read if the target address does not exist. The error flag also asserts when the target address of an SPI write does not exist or is read only. No error. Error.	0x0	R
1	SCLK_ERR_FLAG	0 1	Error flag for the detection of the correct number of SCLK cycles in an SPI frame. No error. Error.	0x0	R
0	CRC_ERR_FLAG	0 1	Error flag that determines if a CRC error occurred during a register write. No error. Error.	0x0	R

BURST ENABLE REGISTER

Address: 0x05, Reset: 0x00, Name: BURST_EN

The burst enable register allows the user to enable or disable burst mode. When enabled, the user can send multiple consecutive SPI commands without deasserting \overline{CS} .

Table 20. Bit Descriptions for BURST_EN

Bit(s)	Bit Name	Settings	Description	Default	Access
[7:1]	Reserved		These bits are reserved. Set these bits to 0.	0x0	R
0	BURST_MODE_EN	0 1	Burst mode enable bit. Disabled. Enabled.	0x0	R/W

ROUND ROBIN ENABLE REGISTER

Address: 0x06, Reset: 0x00, Name: ROUND_ROBIN_EN

The round robin register allows the user to enable or disable round robin mode. When enabled, the user can cycle through the channels enabled in the round robin configuration register by presenting the relevant edge on the CNV pin.

Table 21. Bit Descriptions for ROUND_ROBIN_EN

Bit(s)	Bit Name	Settings	Description	Default	Access
[7:1]	Reserved		These bits are reserved. Set these bits to 0.	0x0	R
0	ROUND_ROBIN_EN	0 1	Round robin mode enable bit. Disabled. Enabled.	0x0	R/W

ROUND ROBIN CHANNEL CONFIGURATION REGISTER

Address: 0x07, Reset: 0xFF (ADGS1408), 0x0F (ADGS1409), Name: RROBIN_CHANNEL_CONFIG

The round robin channel configuration register controls which channels are included in a cycle during round robin mode. During round robin mode, the channels are cycled through in ascending order.

Table 22. Bit Descriptions for RROBIN_CHANNEL_CONFIG, ADGS1408

Bit(s)	Bit Name	Settings	Description	Default	Access
7	S8_EN	0 1	Enable bit for S8. S8 disabled during round robin mode. S8 enabled during round robin mode.	0x1	R/W
6	S7_EN	0 1	Enable bit for S7. S7 disabled during round robin mode. S7 enabled during round robin mode.	0x1	R/W
5	S6_EN	0 1	Enable bit for S6. S6 disabled during round robin mode. S6 enabled during round robin mode.	0x1	R/W
4	S5_EN	0 1	Enable bit for S5. S5 disabled during round robin mode. S5 enabled during round robin mode.	0x1	R/W
3	S4_EN	0 1	Enable bit for S4. S4 disabled during round robin mode. S4 enabled during round robin mode.	0x1	R/W
2	S3_EN	0 1	Enable bit for S3. S3 disabled during round robin mode. S3 enabled during round robin mode.	0x1	R/W

Bit(s)	Bit Name	Settings	Description	Default	Access
1	S2_EN	0 1	Enable bit for S2. S2 disabled during round robin mode. S2 enabled during round robin mode.	0x1	R/W
0	S1_EN	0 1	Enable bit for S1. S1 disabled during round robin mode. S1 enabled during round robin mode.	0x1	R/W

Table 23. Bit Descriptions for RROBIN_CHANNEL_CONFIG, ADGS1409

Bit(s)	Bit Name	Settings	Description	Default	Access
[7:4]	Reserved		These bits are reserved. Set these bits to 0.	0x0	R
3	S4_EN	0 1	Enable bit for S4. S4 disabled during round robin mode. S4 enabled during round robin mode.	0x1	R/W
2	S3_EN	0 1	Enable bit for S3. S3 disabled during round robin mode. S3 enabled during round robin mode.	0x1	R/W
1	S2_EN	0 1	Enable bit for S2. S2 disabled during round robin mode. S2 enabled during round robin mode.	0x1	R/W
0	S1_EN	0 1	Enable bit for S1. S1 disabled during round robin mode. S1 enabled during round robin mode.	0x1	R/W

CNV EDGE SELECT REGISTER

Address: 0x06, Reset: 0x00, Name: CNV_EDGE_SEL

The CNV edge select register allows the user to select the active edge of the CNV pin when the device is in round robin mode.

Table 24. Bit Descriptions for CNV_EDGE_SEL

Bit(s)	Bit Name	Settings	Description	Default	Access
[7:1]	Reserved		These bits are reserved. Set these bits to 0.	0x0	R
0	CNV_EDGE_SEL	0 1	CNV active edge select bit. Falling edge of CNV is the active edge. Rising edge of CNV is the active edge.	0x0	R/W

SOFTWARE RESET REGISTER

Address: 0x0B, Reset: 0x00, Name: SOFT_RESETB

Use the software reset register to perform a software reset. Write 0xA3 followed by 0x05 consecutively to this register, and the registers of the device reset to their default state.

Table 25. Bit Descriptions for SOFT_RESETB

Bit(s)	Bit Name	Settings	Description	Default	Access
[7:0]	SOFT_RESETB		To perform a software reset, consecutively write 0xA3 followed by 0x05 to this register.	0x0	R

OUTLINE DIMENSIONS

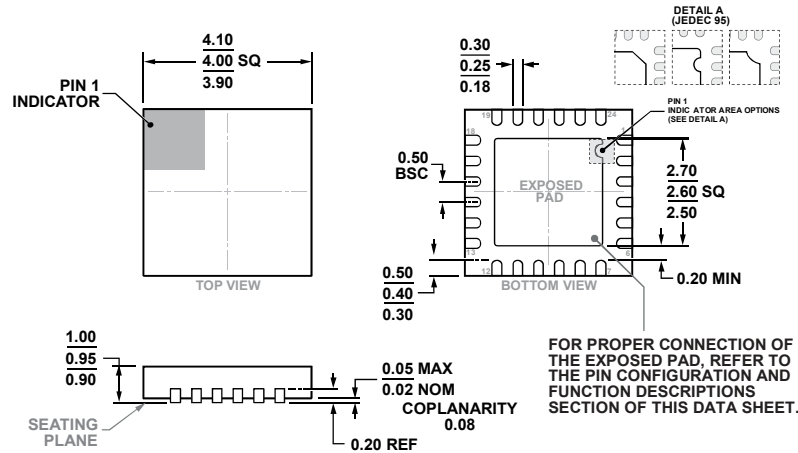

COMPLIANT TO JEDEC STANDARDS MO-220-VGGD-8.

Figure 55. 24-Lead Lead Frame Chip Scale Package [LFCSP]
4 mm × 4 mm Body and 0.95 mm Package Height
(CP-24-17)

Dimensions shown in millimeters

ORDERING GUIDE

Model ¹	Temperature Range	Package Description	Package Option
ADGS1408BCPZ	-40°C to +125°C	24-Lead Lead Frame Chip Scale Package [LFCSP]	CP-24-17
ADGS1408BCPZ-RL7	-40°C to +125°C	24-Lead Lead Frame Chip Scale Package [LFCSP]	CP-24-17
ADGS1409BCPZ	-40°C to +125°C	24-Lead Lead Frame Chip Scale Package [LFCSP]	CP-24-17
ADGS1409BCPZ-RL7	-40°C to +125°C	24-Lead Lead Frame Chip Scale Package [LFCSP]	CP-24-17
EVAL-ADGS1408SDZ		ADGS1408 Evaluation Board	
EVAL-ADGS1409SDZ		ADGS1409 Evaluation Board	

¹ Z = RoHS Compliant Part.