

Description

The AZV3001A is a single comparator developed for new generation low-power comparator families for battery-powered devices and systems requiring low voltage operation.

The supply current each comparator typically consumes 6 μ A to extend battery life. It is guaranteed to operate at a low voltage of 1.6V and is fully operational up to 5.5V. These features make the AZV3001A convenient for use in 1.8V, 3.0V and 5.0V system, and is perfectly suitable for battery-powered devices from its low-power characteristics.

The AZV3001A has complementary push-pull output stage comprised of P- and N-Channel MOSFET for each comparator capable of driving rail-to-rail output swing. The AZV3001A is available in X2-DFN1410-6.

Features

- Low Supply Current: 6 μ A (Typical)
- Wide Supply Voltage Range: 1.6V to 5.5V
- Rail to Rail Input/ Output Performance
- Push-Pull Output Structure
- Propagation Delay: 0.8 μ s (Typical)
- Low Input Bias Current: 1pA (Typical)
- No Phase Inversion with Overdrive Input Signals
- Internal Hysteresis
- X2-DFN1410-6: Available in "Green" Molding Compound (No Br. Sb.)
- **Totally Lead-Free & Fully RoHS Compliant (Notes 1 & 2)**
- **Halogen and Antimony Free. "Green" Device (Note 3)**
- **For automotive applications requiring specific change control (i.e. parts qualified to AEC-Q100/101/200, PPAP capable, and manufactured in IATF 16949 certified facilities), please [contact us](https://www.diodes.com/quality/product-definitions/) or your local Diodes representative.**

<https://www.diodes.com/quality/product-definitions/>

Applications

- Mobile Phones
- Tablets
- Battery Powered Devices
- Alarm and Security Systems

Notes: 1. No purposely added lead. Fully EU Directive 2002/95/EC (RoHS), 2011/65/EU (RoHS 2) & 2015/863/EU (RoHS 3) compliant.
 2. See <https://www.diodes.com/quality/lead-free/> for more information about Diodes Incorporated's definitions of Halogen- and Antimony-free, "Green" and Lead-free.
 3. Halogen- and Antimony-free "Green" products are defined as those which contain <900ppm bromine, <900ppm chlorine (<1500ppm total Br + Cl) and <1000ppm antimony compounds.

Pin Assignments

AZV3001A

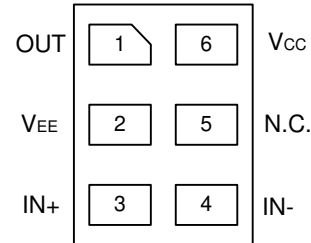

**Top View
(X2-DFN1410-6)**

Pin Descriptions

Pin Name	Pin Number	Function
V _{CC}	6	Supply Voltage
V _{EE}	2	Supply Voltage
IN+	3	Non-Inverting Input
IN-	4	Inverting Input
OUT	1	Comparator Output
N.C.	5	No Connection

Functional Block Diagram

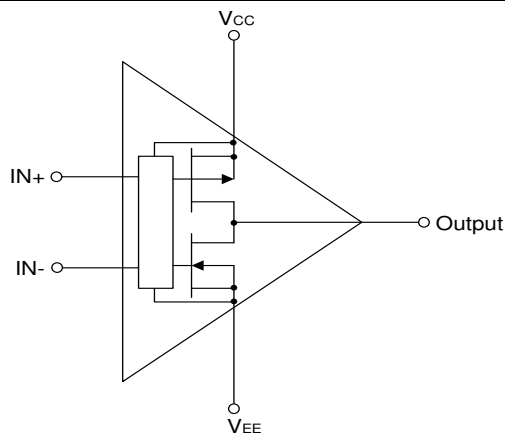

Absolute Maximum Ratings (Note 4) (@T_A = +25°C, unless otherwise specified.)

Symbol	Parameter	Min	Max	Unit
V _{CC}	Supply Voltage	—	6	V
V _I	Input Voltage	-0.3	V _{CC} +0.3	V
t _{SC(O)}	Output Short-Circuit Time	—	Indefinite	s
T _{J(MAX)}	Maximum Junction Temperature	—	+150	°C
T _{STG}	Storage Temperature	-65	+150	°C
θ _{JA}	Thermal Resistance (Junction-to-Ambient)	X2-DFN1410-6		315 °C/W
θ _{JC}	Thermal Resistance (Junction-to-Case)	X2-DFN1410-6		150 °C/W

Note: 4. Stresses greater than the *Absolute Maximum Ratings* specified above can cause permanent damage to the device. These are stress ratings only; functional operation of the device at these or any other conditions exceeding those indicated in this specification is not implied. Device reliability can be affected by exposure to absolute maximum rating conditions for extended periods of time.

DC Electrical Characteristics ($V_{CC} = 1.6V$ to $5.5V$, $V_{EE} = 0V$; $V_{CM} = 0.5V_{CC}$, unless otherwise specified.)

Symbol	Parameter	Conditions	+25°C			-40°C to +85°C		Unit
			Min	Typ	Max	Min	Max	
V _{HYST}	Hysteresis Voltage	—	6	9	13	—	—	mV
		V _{CC} = 1.3V	—	20	—	—	—	mV
V _{I(OFFSET)}	Offset Input Voltage	—	-30	0.5	+30	-30	+30	mV
		V _{CC} = 1.3V	—	3	—	—	—	mV
V _{OH}	High-Level Output Voltage	I _O = -0.5mA; V _{CC} = 1.3V	—	1.24	—	—	—	V
		I _O = -0.5mA; V _{CC} = 1.6V	—	1.55	—	1.35	—	V
		I _O = -3mA; V _{CC} = 3.0V	—	2.85	—	2.7	—	V
		I _O = -5mA; V _{CC} = 5.5V	—	5.33	—	5.2	—	V
V _{OL}	Low-Level Output Voltage	I _O = -0.5mA; V _{CC} = 1.3V	—	0.05	—	—	—	V
		I _O = -0.5mA; V _{CC} = 1.6V	—	0.04	—	—	0.25	V
		I _O = -3mA; V _{CC} = 3.0V	—	0.14	—	—	0.3	V
		I _O = -5mA; V _{CC} = 5.5V	—	0.2	—	—	0.3	V
V _{CM}	Common-Mode Voltage	V _{CC} = 1.3V to 5.5V	—	V _{EE} to V _{CC}	—	—	—	V
I _{OS}	Output Short-Circuit Current	V _{CC} = 5.5V; V _O = V _{EE} or V _{CC}	—	68	—	—	—	mA
CMRR	Common-Mode Rejection Ratio	ΔV _{CM} = V _{CC}	—	70	—	—	—	dB
PSRR	Power Supply Rejection Ratio	ΔV _{CC} = 1.95V	45	80	—	—	—	dB
I _{IB}	Input Bias Current	—	—	1	—	—	—	pA
I _{CC}	Supply Current	—	—	6	—	—	9	μA

AC Electrical Characteristics ($V_{CC} = 1.6V$ to $5.5V$, $V_{EE} = 0V$; $V_{CM} = 0.5V_{CC}$, unless otherwise specified.)

Symbol	Parameter	Conditions	Min	Typ	Max	Unit
t _{PD}	Propagation Delay	20mV Overdrive; C _L = 15pF	—	0.8	—	μs
t _{THL}	High to Low Output Transition Time	V _{CC} = 5.5V; C _L = 50pF	—	10	—	ns
t _{TLH}	Low to High Output Transition Time	V _{CC} = 5.5V; C _L = 50pF	—	10	—	ns

Performance Characteristics

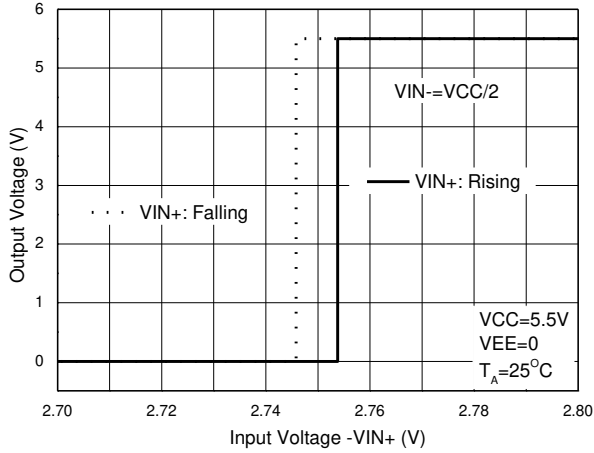

Figure 1. Input Hysteresis Voltage

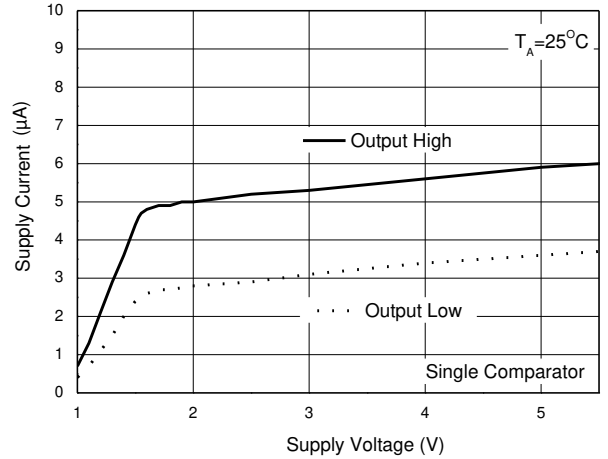

Figure 2. Supply Current vs. Supply Voltage

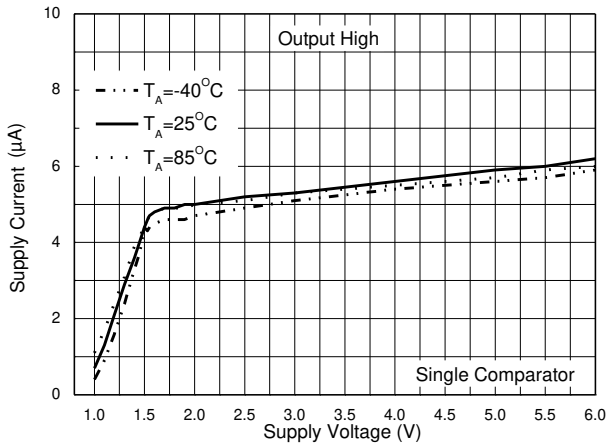

Figure 3. Supply Current vs. Supply Voltage

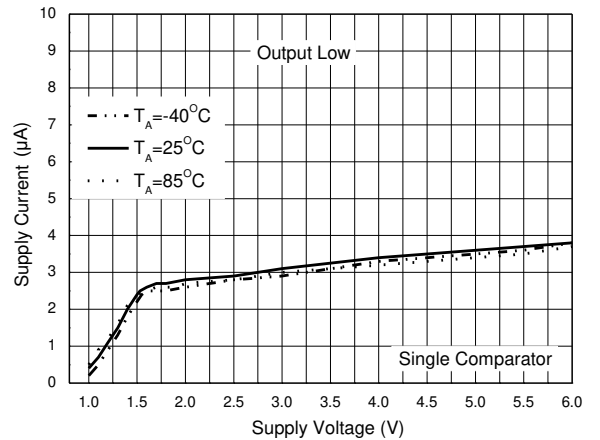

Figure 4. Supply Current vs. Supply Voltage

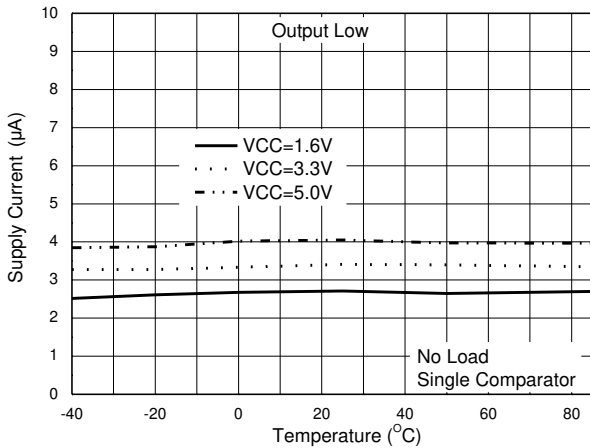

Figure 5. Supply Current vs. Temperature

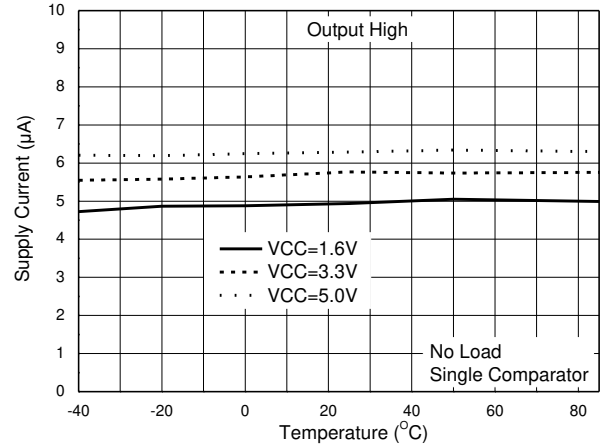

Figure 6. Supply Current vs. Temperature

Performance Characteristics (continued)

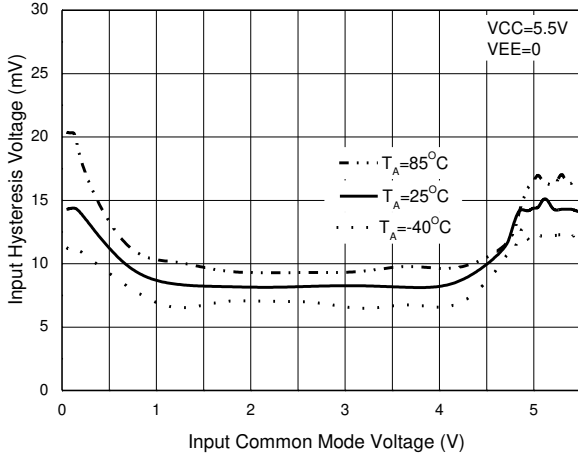

Figure 7. Input Hysteresis Voltage

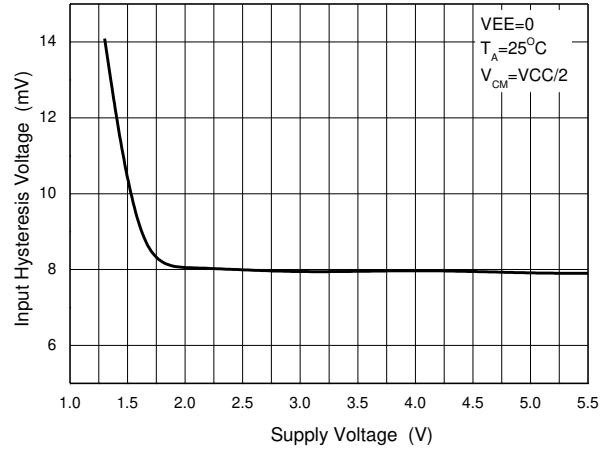

Figure 8. Input Hysteresis Voltage

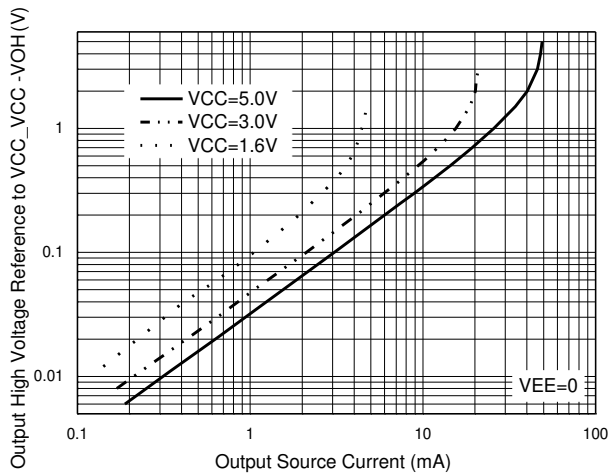

Figure 9. Output Voltage vs. Output Source Current

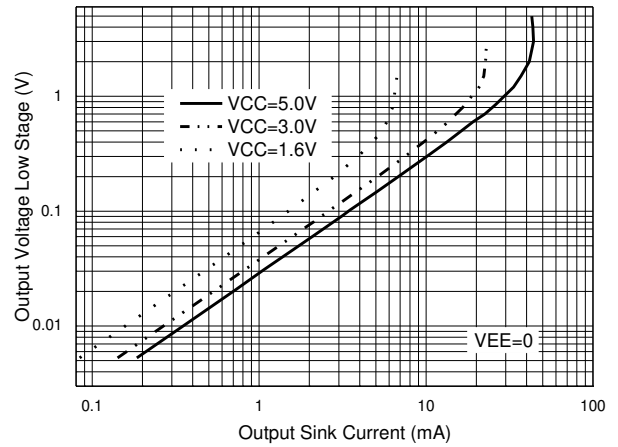

Figure 10. Output Voltage vs. Output Sink Current

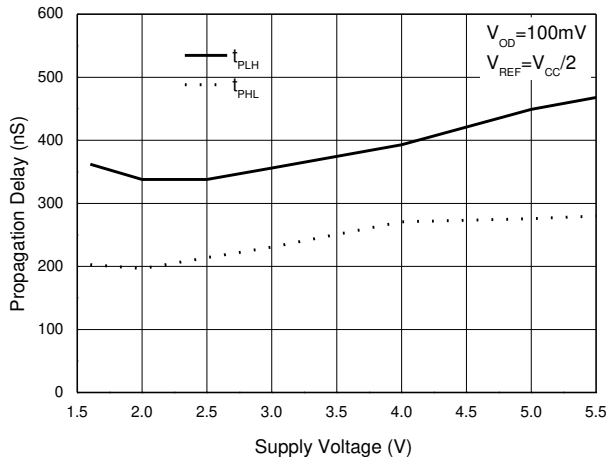

Figure 11. Propagation Delay vs. Supply Voltage

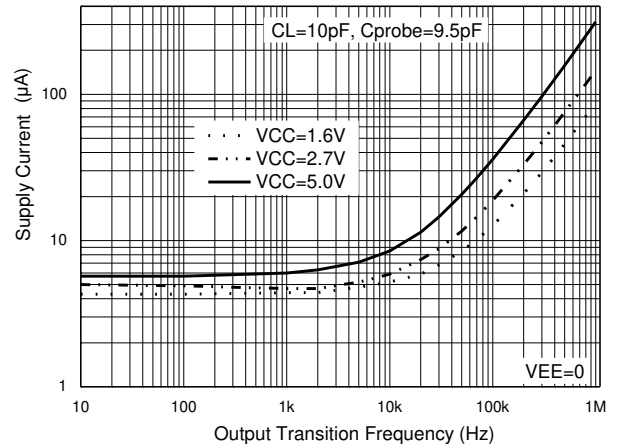

Figure 12. Supply Current vs. Transition Frequency

Application Information

Description

The AZV3001A is a single and dual low-voltage, low-power comparator. These devices are designed for rail-to-rail input and output applications. The AZV3001A device consumes only 6µA supply current while achieving a typical propagation delay 0.8µs under 20mV input overdrive condition. These family comparators are guaranteed to operate at a low supply voltage range from 1.6V to 5.5V.

The AZV3001A has a typical internal hysteresis of 9.0mV. This allows for greater noise immunity and clean output switching.

The Output Stage

The AZV3001A features a push-pull output, which has a complementary P- and N-Channel output stage. When the output switches, there is a direct path between V_{CC} and V_{EE}, causing increased output sinking or sourcing current during the transition. Following the transition, the output current decreases and supply current returns to 6µA, thus maintaining low power consumption.

Many comparators consume more current during switching than during steady-state operation. However, with this family of comparators, the supply current change during an output transition is extremely small. The graph of Supply Current vs. Output Transition Frequency shows the minimal supply current increase as the output switching frequency approaches 1kHz. In battery- powered applications, this characteristic results in a substantial increase in battery life.

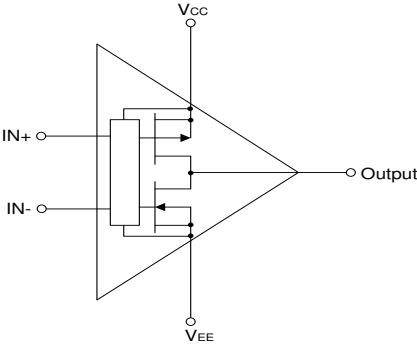

Figure 13. AZV3001A Complementary Output Configuration

Internal Input Hysteresis Voltage (V_{HYST})

Many comparators oscillate in the linear region of operation because of noise or undesired parasitic feedback. This tends to occur when the voltage on one input is equal to, or very close to the voltage on the other input. The AZV3001A has internal 9mV (Typ.) hysteresis to counter parasitic effects and noise.

The hysteresis in a comparator creates two trip points: one for the rising input voltage (V_{HYST+}) and one for the falling input voltage (V_{HYST-}). The difference between the trip points is the hysteresis (V_{HYST}). When the comparator's input voltages are equal, the hysteresis effectively causes one comparator input to move quickly past the other, thus taking the input out of the region where oscillation occurs. Figure 1 illustrates the case in which V_{IN-} has a fixed voltage applied, and V_{IN+} is varied. If the inputs were reversed, the figure would be the same, except with an inverted output.

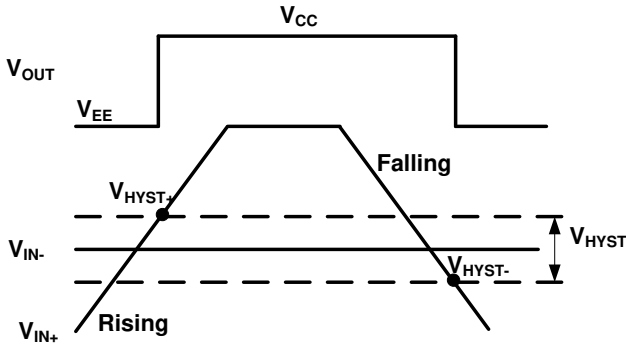

Figure 14. AZV3001A Internal Input Hysteresis Voltage

Application Information (continued)

External Hysteresis Application

The AZV3001A has a hysteresis transfer curve that is a function of the following three components:

V_{TH} : the actual set voltage or threshold trip voltage

V_{OS} : the internal offset voltage between V_{IN+} and V_{IN-} . This voltage is added to V_{TH} to form the actual trip point at which the comparator must respond in order to change output states.

V_{HYST} : internal hysteresis (or trip window) that is designed to produce comparator sensitivity to noise.

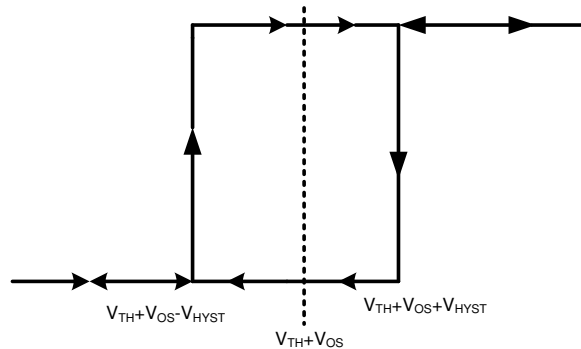

Figure 15. AZV3001A Hysteresis Transfer Curve

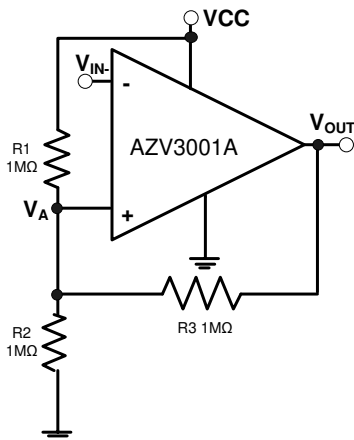

Figure 16. Inverting Comparator With Hysteresis

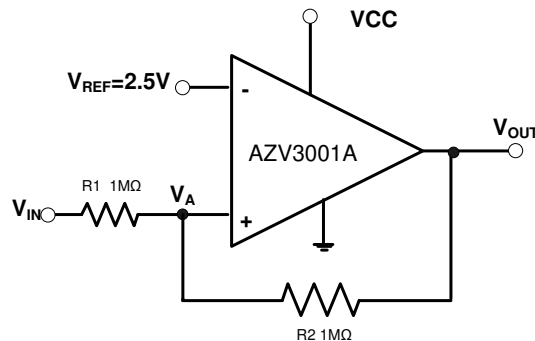

Figure 17. Non-Inverting Comparator With Hysteresis

No Phase Inversion

The AZV3001A is rail-to-rail input comparators, with the input common-mode voltage range reaching to the supply rails for both positive and negative supplies. The AZV3001A is designed to prevent phase inversion when the input pins exceed the supply voltage. Figure 18 shows the AZV3001A responses when input voltages exceed the supply, resulting in no phase inversion.

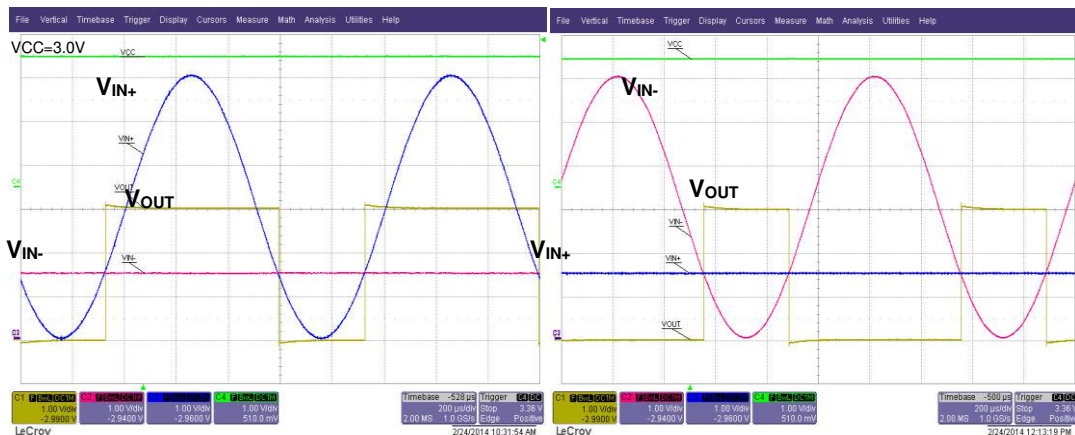
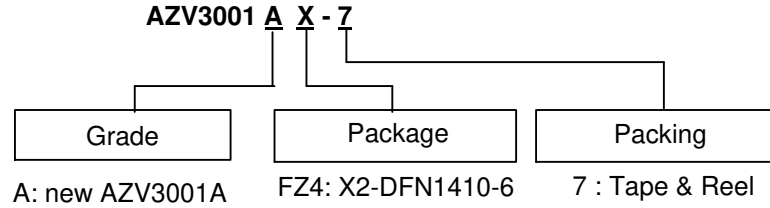

Figure 18. Comparator Response to Input Voltage –No Phase Inversion

Ordering Information



Part Number	Package Code	Packaging	7" Tape and Reel	
			Quantity	Part Number Suffix
AZV3001AFZ4-7	FZ4	X2-DFN1410-6	5,000/Tape & Reel	-7

Note: 5. Pad layout as shown on Diodes Incorporated's suggested pad layout, which can be found on our website at <http://www.diodes.com/packageoutlines.html>.

Marking Information

(1) X2-DFN1410-6

(Top View)

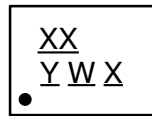

XX : Identification Code

Y : Year : 0 to 9

W : Week : A to Z : 1 to 26 Week;
a to z : 27 to 52 Week; z Represents
52 and 53 Week

X : Internal Code

Part Number	Package	Identification Code
AZV3001AFZ4-7	X2-DFN1410-6	YB

Package Outline Dimensions

Please see <http://www.diodes.com/package-outlines.html> for the latest version.

X2-DFN1410-6

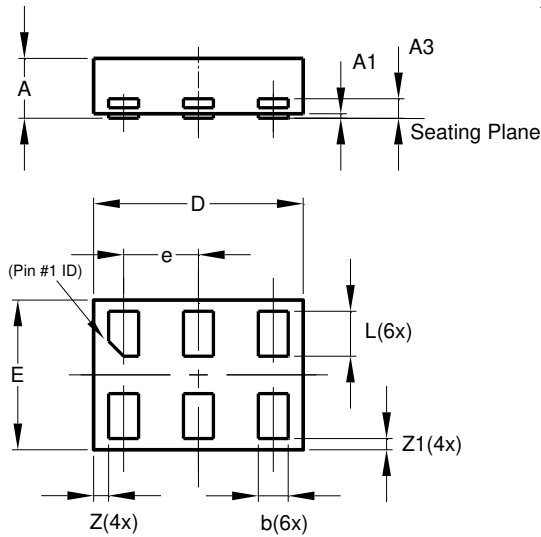

X2-DFN1410-6			
Dim	Min	Max	Typ
A	—	0.40	0.39
A1	0.00	0.05	0.02
A3	—	—	0.13
b	0.15	0.25	0.20
D	1.35	1.45	1.40
E	0.95	1.05	1.00
e	—	—	0.50
L	0.25	0.35	0.30
Z	—	—	0.10
Z1	0.045	0.105	0.075
All Dimensions in mm			

Suggested Pad Layout

Please see <http://www.diodes.com/package-outlines.html> for the latest version.

X2-DFN1410-6

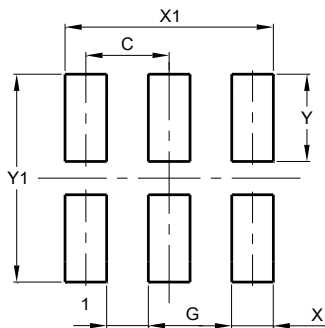

Dimensions	Value (in mm)
C	0.500
G	0.250
X	0.250
X1	1.250
Y	0.525
Y1	1.250

Mechanical Data

- Moisture Sensitivity: Level 1 per J-STD-020
- Terminals: Finish- NiPdAu over Copper Lead- Frame. Solderable per MIL-STD-202, Method 208 (e4)
- Weight: 1.632mg (Approximate)

IMPORTANT NOTICE

1. DIODES INCORPORATED AND ITS SUBSIDIARIES ("DIODES") MAKE NO WARRANTY OF ANY KIND, EXPRESS OR IMPLIED, WITH REGARDS TO ANY INFORMATION CONTAINED IN THIS DOCUMENT, INCLUDING, BUT NOT LIMITED TO, THE IMPLIED WARRANTIES OF MERCHANTABILITY, FITNESS FOR A PARTICULAR PURPOSE OR NON-INFRINGEMENT OF THIRD PARTY INTELLECTUAL PROPERTY RIGHTS (AND THEIR EQUIVALENTS UNDER THE LAWS OF ANY JURISDICTION).
2. The Information contained herein is for informational purpose only and is provided only to illustrate the operation of Diodes products described herein and application examples. Diodes does not assume any liability arising out of the application or use of this document or any product described herein. This document is intended for skilled and technically trained engineering customers and users who design with Diodes products. Diodes products may be used to facilitate safety-related applications; however, in all instances customers and users are responsible for (a) selecting the appropriate Diodes products for their applications, (b) evaluating the suitability of the Diodes products for their intended applications, (c) ensuring their applications, which incorporate Diodes products, comply the applicable legal and regulatory requirements as well as safety and functional-safety related standards, and (d) ensuring they design with appropriate safeguards (including testing, validation, quality control techniques, redundancy, malfunction prevention, and appropriate treatment for aging degradation) to minimize the risks associated with their applications.
3. Diodes assumes no liability for any application-related information, support, assistance or feedback that may be provided by Diodes from time to time. Any customer or user of this document or products described herein will assume all risks and liabilities associated with such use, and will hold Diodes and all companies whose products are represented herein or on Diodes' websites, harmless against all damages and liabilities.
4. Products described herein may be covered by one or more United States, international or foreign patents and pending patent applications. Product names and markings noted herein may also be covered by one or more United States, international or foreign trademarks and trademark applications. Diodes does not convey any license under any of its intellectual property rights or the rights of any third parties (including third parties whose products and services may be described in this document or on Diodes' website) under this document.
5. Diodes products are provided subject to Diodes' Standard Terms and Conditions of Sale (<https://www.diodes.com/about/company/terms-and-conditions/terms-and-conditions-of-sales/>) or other applicable terms. This document does not alter or expand the applicable warranties provided by Diodes. Diodes does not warrant or accept any liability whatsoever in respect of any products purchased through unauthorized sales channel.
6. Diodes products and technology may not be used for or incorporated into any products or systems whose manufacture, use or sale is prohibited under any applicable laws and regulations. Should customers or users use Diodes products in contravention of any applicable laws or regulations, or for any unintended or unauthorized application, customers and users will (a) be solely responsible for any damages, losses or penalties arising in connection therewith or as a result thereof, and (b) indemnify and hold Diodes and its representatives and agents harmless against any and all claims, damages, expenses, and attorney fees arising out of, directly or indirectly, any claim relating to any noncompliance with the applicable laws and regulations, as well as any unintended or unauthorized application.
7. While efforts have been made to ensure the information contained in this document is accurate, complete and current, it may contain technical inaccuracies, omissions and typographical errors. Diodes does not warrant that information contained in this document is error-free and Diodes is under no obligation to update or otherwise correct this information. Notwithstanding the foregoing, Diodes reserves the right to make modifications, enhancements, improvements, corrections or other changes without further notice to this document and any product described herein. This document is written in English but may be translated into multiple languages for reference. Only the English version of this document is the final and determinative format released by Diodes.
8. Any unauthorized copying, modification, distribution, transmission, display or other use of this document (or any portion hereof) is prohibited. Diodes assumes no responsibility for any losses incurred by the customers or users or any third parties arising from any such unauthorized use.

Copyright © 2021 Diodes Incorporated

www.diodes.com