

WHITE LED STEP-UP CONVERTER
AP3030
General Description

The AP3030 is an inductor-based DC/DC converter designed to drive up to eight white LEDs in series or 2 rows of LEDs with 5 for each in parallel for backlight. Only one feedback resistor is needed to control the LED current and obtain required brightness.

A constant frequency 1.2MHz PWM control scheme is employed in this IC, which means tiny external components can be used. Specifically, 1mm tall inductor and 0.22 μ F output capacitor for a typical application are sufficient. Additionally, the schottky diode in boost circuit is integrated on this chip. AP3030 also provides a disable pin to ease its use for different systems.

The output over-voltage protection is implemented in AP3030. When any LED is broken or in other abnormal conditions, the output voltage will be clamped.

The AP3030 is available in standard SOT-23-6 and TSOT-23-6 packages.

Features

- Inherently Uniform LED Current
- High Efficiency up to 84%
- No Need for External Schottky Diode
- Output Over-Voltage Protection (OVP)
- Fixed 1.2MHz Switching Frequency
- Uses Tiny 1mm Tall Inductor
- Requires Only 0.22 μ F Output Capacitor

Applications

- Cellular Phones
- Digital Cameras
- LCD modules
- GPS Receivers
- PDAs, Handheld Computers

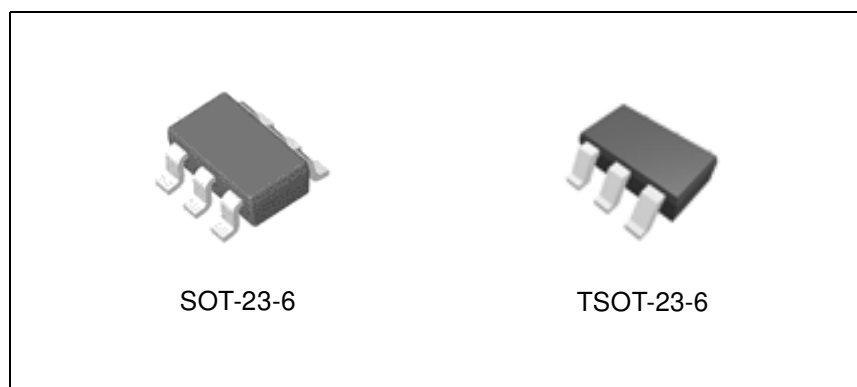

Figure 1. Package Types of AP3030

WHITE LED STEP-UP CONVERTER
AP3030
Pin Configuration

Figure 2. Pin Configuration of AP3030 (Top View)

Pin Description

Pin Number	Pin Name	Function
1	SW	Switch Pin. Connect external inductor
2	GND	Ground
3	FB	Voltage Feedback. Reference voltage is 200mV
4	CTRL	Shutdown and Dimming Pin. Connect to 1.8V or higher to enable device; Connect to 50mV or less to disable device; Connect to a voltage between 1.8V and 50mV to achieve linear dimming
5	V _{OUT}	Output Pin. Connected to the cathode of internal schottky diode
6	V _{IN}	Input Supply Pin. Must be locally bypassed

WHITE LED STEP-UP CONVERTER

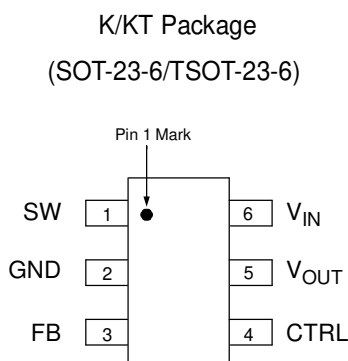
AP3030

Functional Block Diagram

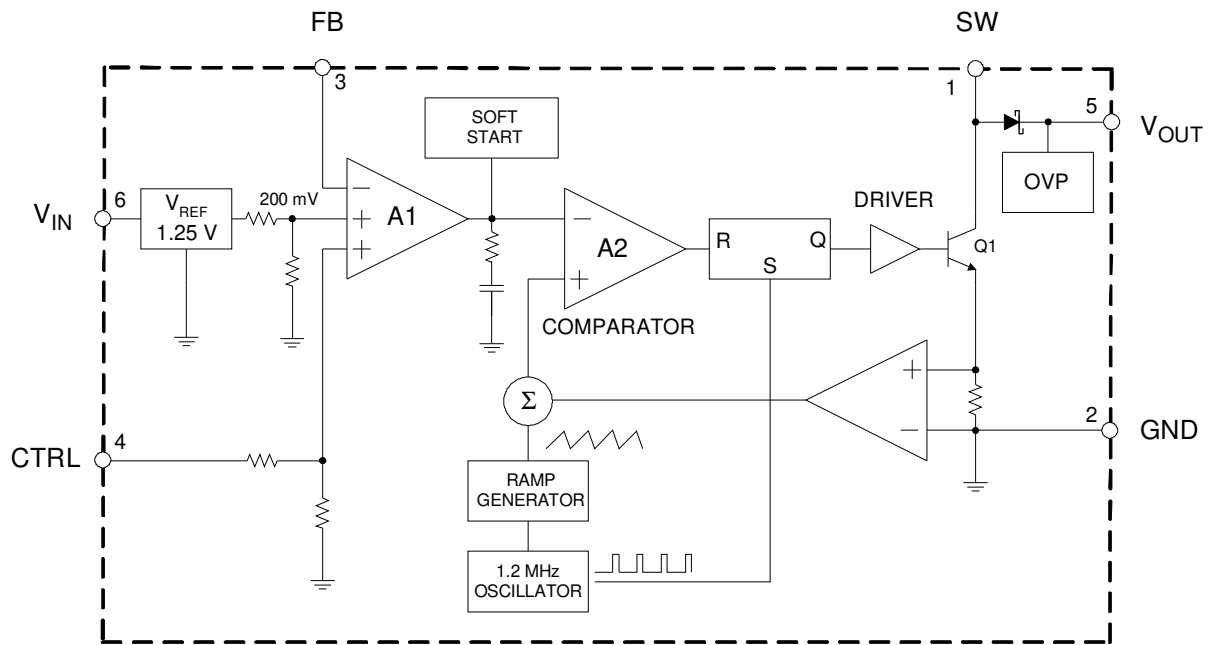
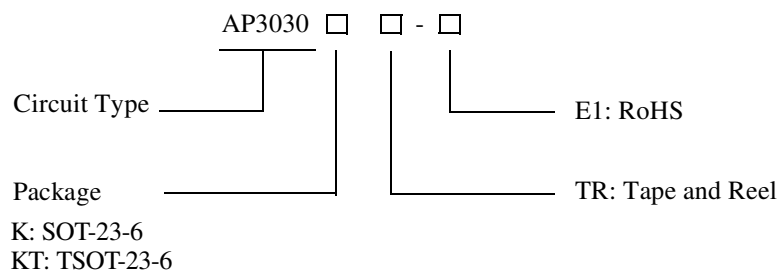

Figure 3. Functional Block Diagram of AP3030

Ordering Information



Package	Temperature Range	Part Number	Marking ID	Packing Type
SOT-23-6	-40 to 85°C	AP3030KTR-E1	EEB	Tape & Reel
TSOT-23-6	-40 to 85°C	AP3030KTTR-E1	S9G	Tape & Reel

BCD Semiconductor's products as designated with "E1" suffix in the part number are RoHS compliant.

**WHITE LED STEP-UP CONVERTER****AP3030****Absolute Maximum Ratings (Note 1)**

Parameter	Symbol	Value	Unit
Input Voltage	V_{IN}	20	V
SW Voltage	V_{SW}	38	V
FB Voltage	V_{FB}	20	V
CTRL Voltage	V_{CTRL}	20	V
Thermal Resistance (Junction to Atmosphere, No Heat Sink)	$R_{\theta JA}$	265	°C/W
Operating Junction Temperature	T_J	150	°C
Storage Temperature Range	T_{STG}	-65 to 150	°C
Lead Temperature (Soldering, 10sec)	T_{LEAD}	260	°C
ESD (Machine Model)		250	V
ESD (Human Body Model)		2000	V

Note 1: Stresses greater than those listed under "Absolute Maximum Ratings" may cause permanent damage to the device. These are stress ratings only, and functional operation of the device at these or any other conditions beyond those indicated under "Recommended Operating Conditions" is not implied. Exposure to "Absolute Maximum Ratings" for extended periods may affect device reliability.

Recommended Operating Conditions

Parameter	Symbol	Min	Max	Unit
Operating Temperature Range	T_{OP}	-40	85	°C
Input Voltage	V_{IN}	2.5	16	V
CTRL Voltage	V_{CTRL}		16	V



WHITE LED STEP-UP CONVERTER

AP3030

Electrical Characteristics

($V_{IN}=3V$, $V_{CTRL}=3V$, $T_A=25^{\circ}C$, unless otherwise specified.)

Parameter	Symbol	Conditions	Min	Typ	Max	Unit
Minimum Operating Voltage	$V_{IN(min)}$		2.5			V
Maximum Operating Voltage	$V_{IN(max)}$				16	
Feedback Voltage	V_{FB}	$I_{OUT}=20mA$, 4 LEDs, $T_A=-40^{\circ}C$ to $85^{\circ}C$	188	200	212	mV
FB Pin Bias Current	I_{FB}			35	100	nA
Quiescent Current	I_Q	$V_{FB}=V_{IN}$, no switching	1.5	2.5	3.2	mA
Shutdown Quiescent Current	I_{SHDN}	$V_{CTRL}=0V$	2.0	3.2	5.0	μA
Switch Frequency	f		0.9	1.2	1.5	MHz
Maximum Duty Cycle	D_{MAX}		90	93		%
Switch Current Limit (Note 2)	I_{LIMIT}	D=40%		550		mA
		D=80%		550		
Switch V_{CE} Saturation Voltage	V_{CESAT}	$I_{SW}=250mA$		360		mV
Switch Leakage Current		$V_{SW}=5V$		0.01	5	μA
CTRL Pin Voltage	V_{CTRL}	High	1.8			V
		Low			0.05	
CTRL Pin Bias Current	I_{CTRL}		40	55	72	μA
		$T_A=85^{\circ}C$		50		
		$T_A=-40^{\circ}C$		75		
OVP Voltage	V_{OV}			30		V
Schottky Forward Drop	V_{DROP}	$I_D=150mA$		0.7		V
Schottky Leakage Current		$V_R=23V$		0.1	4	μA
		$V_R=27V$			150	
Soft Start Time	t			300		μS
Thermal Resistance (Junction to Case)	θ_{JC}	SOT-23-6		60		$^{\circ}C/W$
		TSOT-23-6		60		

Note 2: The switch current limit is related to duty cycle. Please refer to Figure 15 for detail.



WHITE LED STEP-UP CONVERTER

AP3030

Typical Performance Characteristics

(V_F (forward voltage) of WLED is 3.45V @ $I_F=20mA$, unless otherwise noted)

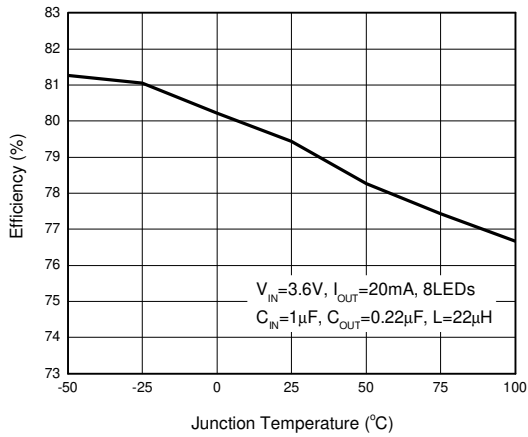

Figure 4. Efficiency vs. Junction Temperature

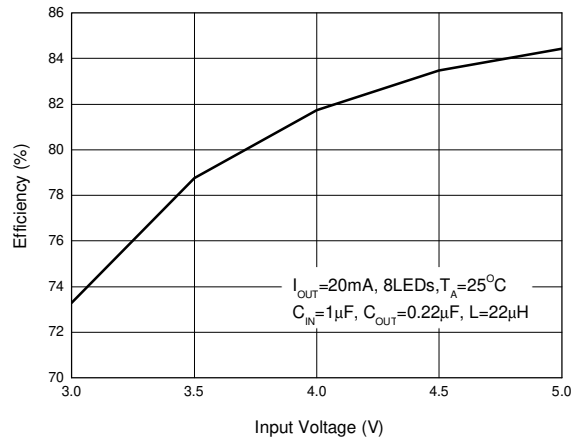

Figure 5. Efficiency vs. Input Voltage

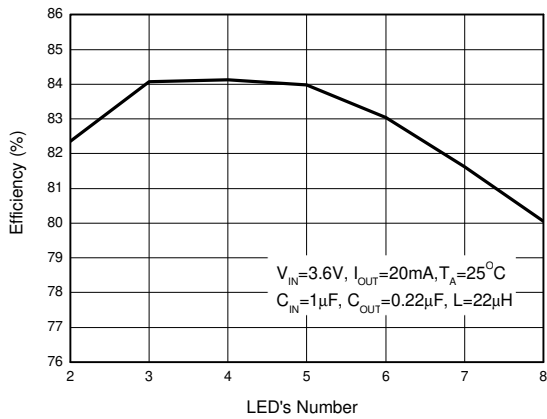

Figure 6. Efficiency vs. LED's Number

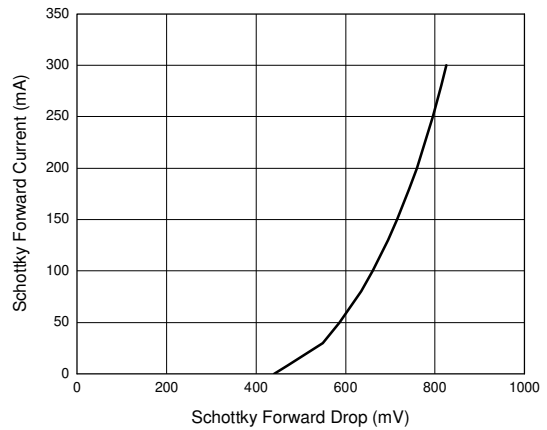

Figure 7. Schottky Forward Current vs. Schottky Forward Drop



WHITE LED STEP-UP CONVERTER

AP3030

Typical Performance Characteristics (Continued)

(V_F (forward voltage) of WLED is 3.45V @ $I_F=20mA$, unless otherwise noted)

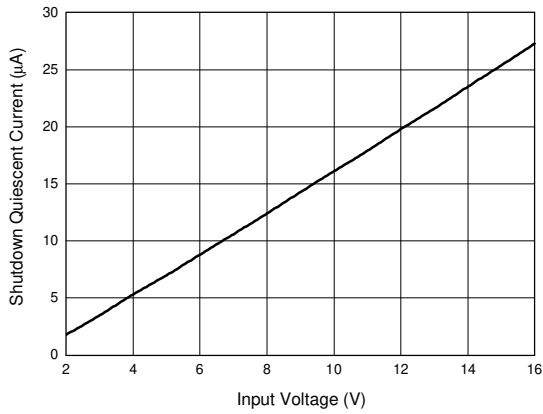

Figure 8. Shutdown Quiescent Current vs. Input Voltage

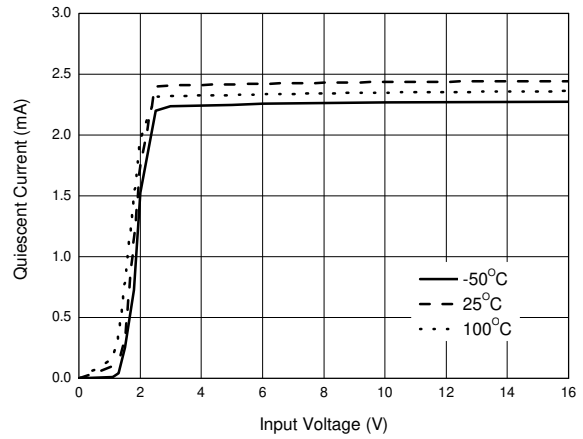

Figure 9. Quiescent Current vs. Input Voltage

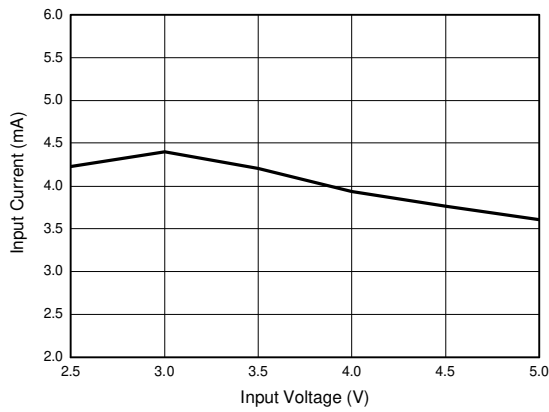

Figure 10. Input Current in Output Open Circuit vs. Input Voltage

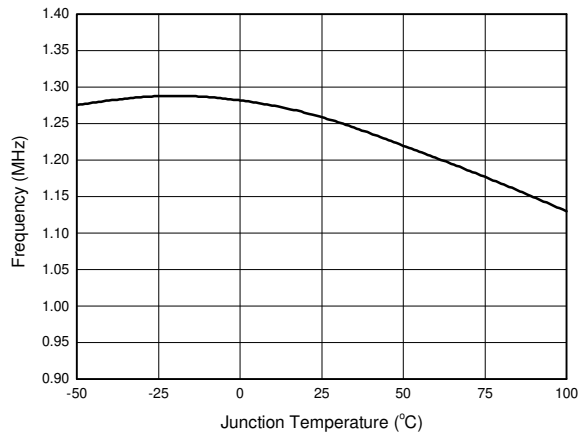

Figure 11. Switch Frequency vs. Junction Temperature



WHITE LED STEP-UP CONVERTER

AP3030

Typical Performance Characteristics (Continued)

(V_F (forward voltage) of WLED is 3.45V @ $I_F=20mA$, unless otherwise noted)

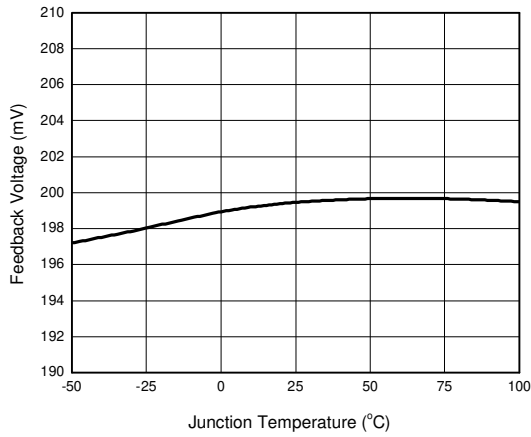

Figure 12. Feedback Voltage vs. Junction Temperature

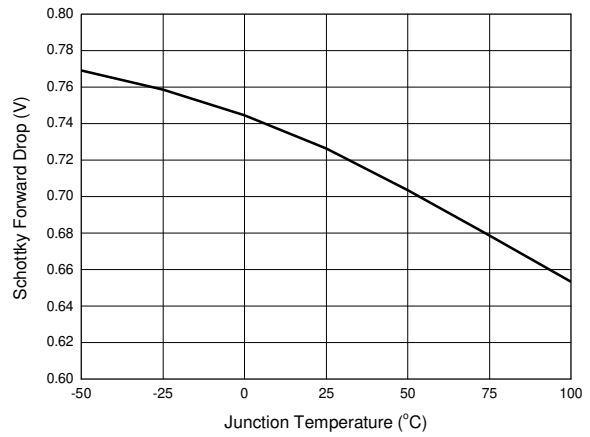

Figure 13. Schottky Forward Drop vs. Junction Temperature

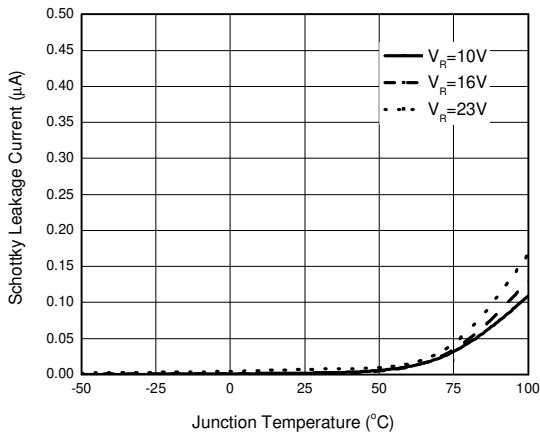

Figure 14. Schottky Leakage Current vs. Junction Temperature

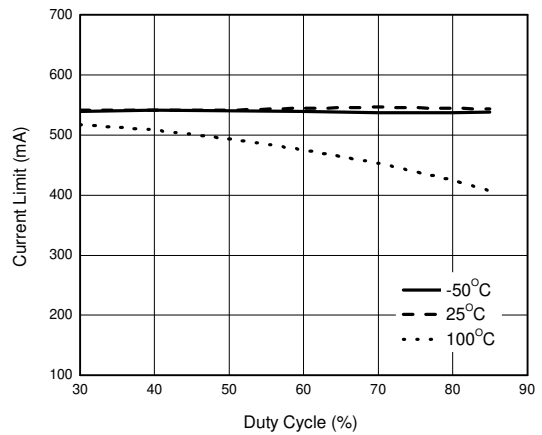

Figure 15. Switch Current Limit vs. Duty Cycle



WHITE LED STEP-UP CONVERTER

AP3030

Typical Performance Characteristics (Continued)

(V_F (forward voltage) of WLED is 3.45V @ $I_F=20mA$, unless otherwise noted)

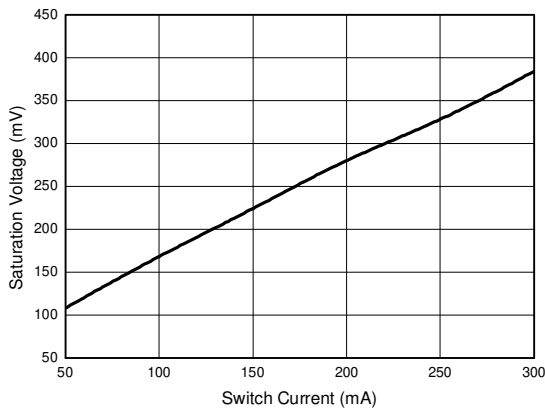

Figure 16. Switch Saturation Voltage vs. Switch Current

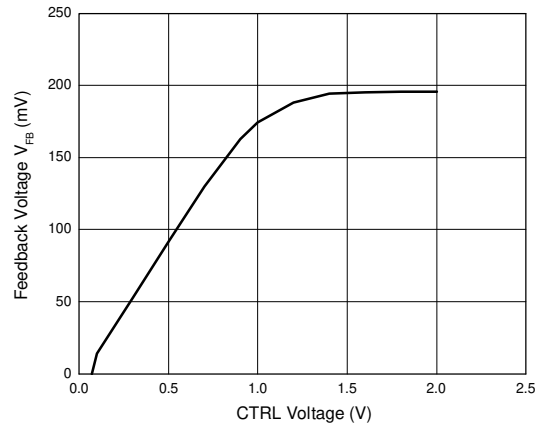
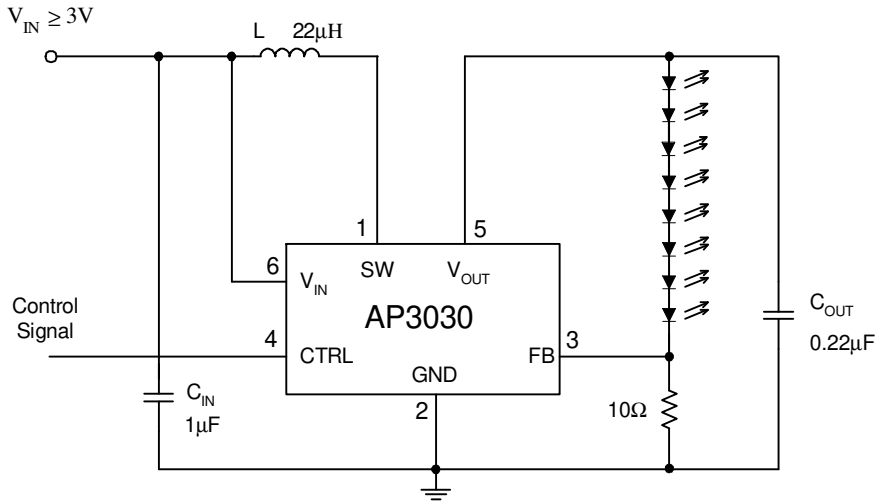

Figure 17. Feedback Voltage vs. CTRL Pin Voltage

WHITE LED STEP-UP CONVERTER

AP3030

Typical Application



C: X5R or X7R Dielectric
 L: SUMIDA CDRH5D28R-220NC or Equivalent
 This circuit can work in full temperature

Figure 18. Typical Application of Eight LED Drivers

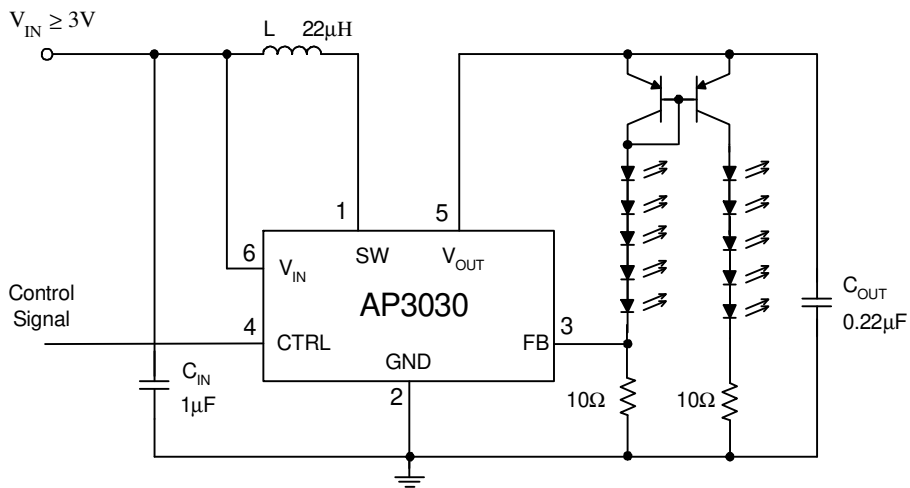

C: X5R or X7R Dielectric
 L: SUMIDA CDRH5D28R-220NC or Equivalent
 Two transistors are recommended to use Dual Matched transistor pairs
 This circuit can work in full temperature

Figure 19. Typical Application of Ten LED Drivers



WHITE LED STEP-UP CONVERTER

AP3030

Mechanical Dimensions

SOT-23-6

Unit: mm(inch)

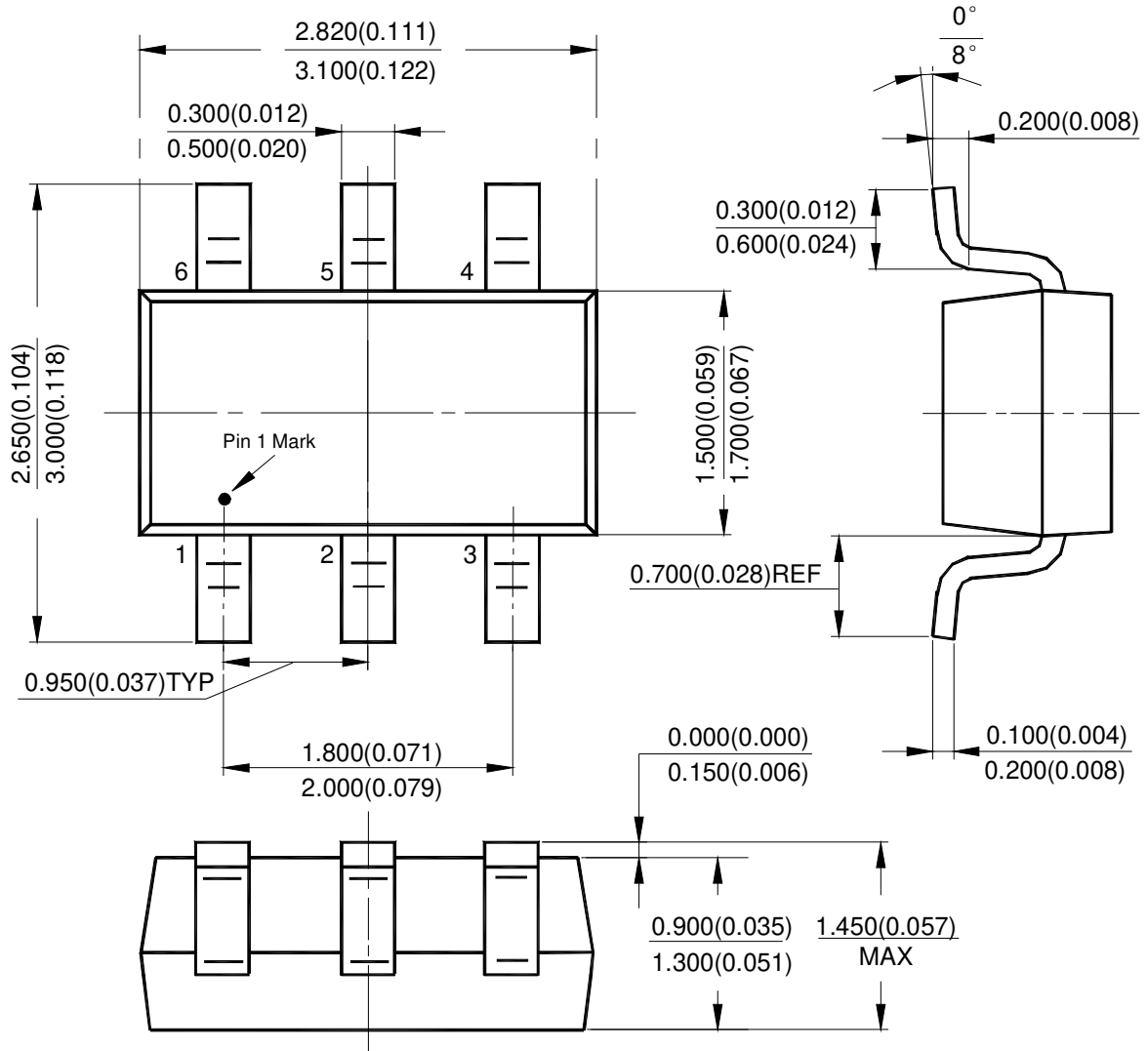



WHITE LED STEP-UP CONVERTER

AP3030

Mechanical Dimensions (Continued)

TSOT-23-6

Unit: mm(inch)

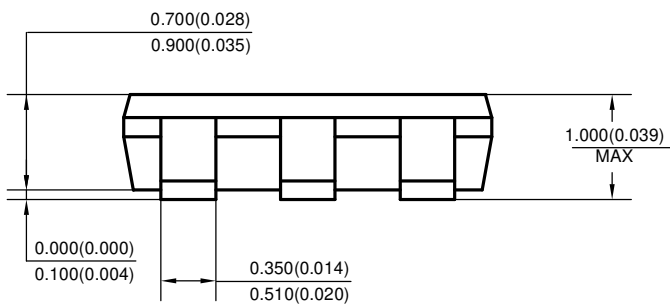
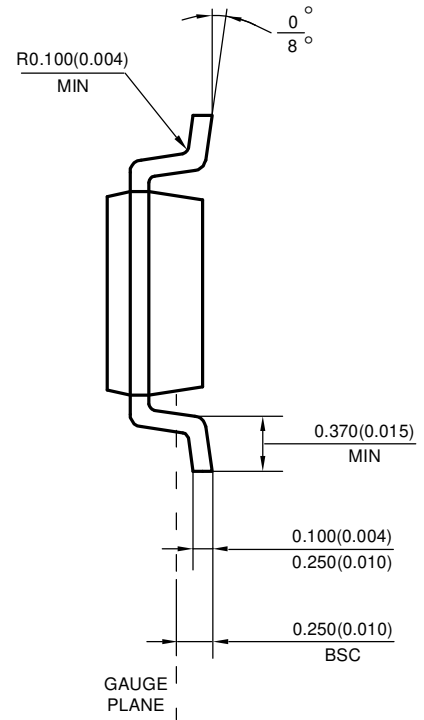
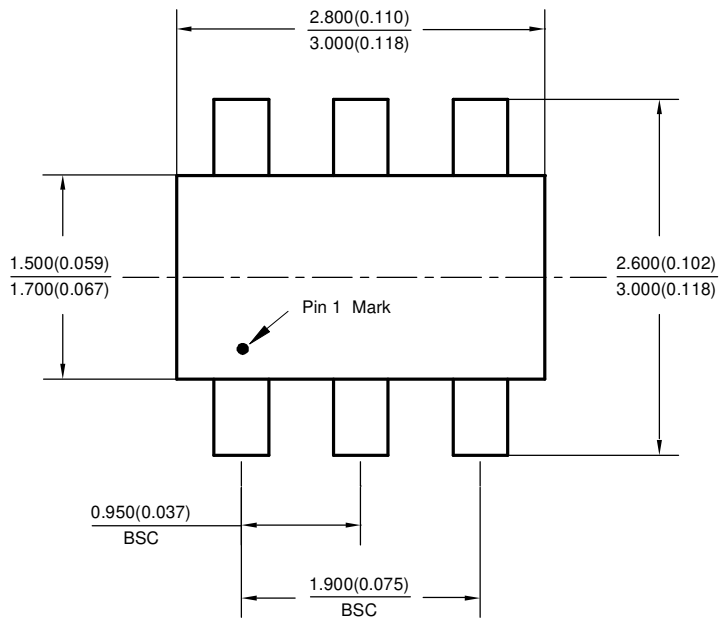



BCD Semiconductor Manufacturing Limited

<http://www.bcdsemi.com>

IMPORTANT NOTICE

BCD Semiconductor Manufacturing Limited reserves the right to make changes without further notice to any products or specifications herein. BCD Semiconductor Manufacturing Limited does not assume any responsibility for use of any its products for any particular purpose, nor does BCD Semiconductor Manufacturing Limited assume any liability arising out of the application or use of any its products or circuits. BCD Semiconductor Manufacturing Limited does not convey any license under its patent rights or other rights nor the rights of others.

MAIN SITE

- Headquarters

BCD (Shanghai) Micro-electronics Limited

No. 1600, Zi Xing Road, Shanghai ZiZhu Science-based Industrial Park, 200241, P. R. C.
Tel: +86-021-2416-2266, Fax: +86-021-2416-2277

- Wafer Fab

Shanghai SIM-BCD Semiconductor Manufacturing Co., Ltd.

800 Yishan Road, Shanghai 200233, China
Tel: +021-6485-1491, Fax: +86-021-5450-0008

REGIONAL SALES OFFICE

Shenzhen Office

Shanghai SIM-BCD Semiconductor Manufacturing Co., Ltd., Shenzhen Office

Unit A Room 1203, Skyworth Bldg., Gaoxin Ave.1.S., Nanshan District
Shenzhen 518057, China

Tel: +86-0755-8660-4900, Fax: +86-0755-8660-4958

Taiwan Office (Taipei)

BCD Semiconductor (Taiwan) Company Limited

3F, No.17, Lane 171, Sec. 2, Jiu-Zong Rd., Nei-Hu Dist., Taipei(114), Taiwan, R.O.C
Tel: +886-2-2656-2808

Fax: +886-2-2656-2806/26562950

Taiwan Office (Hsinchu)

BCD Semiconductor (Taiwan) Company Limited

8F, No.176, Sec. 2, Gong-Dao 5th Road, East District
HsinChu City 300, Taiwan, R.O.C

Tel: +886-3-5160181, Fax: +886-3-5160181

USA Office

BCD Semiconductor Corp.

48460 Kato Road, Fremont, CA 94538, USA
Tel: +1-510-668-1950

Fax: +1-510-668-1990

Korea Office

BCD Semiconductor Limited Korea office.

Room 101-1112, Digital-Empire II, 486 Sin-dong,
Yeongtong-Gu, Suwon-city, Gyeonggi-do, Korea

Tel: +82-31-695-8430