

# SIEMENS

## Microcomputer Components

8-Bit CMOS Microcontroller

# C501

<b>C501 Data Sheet</b>		
<b>Revision History :</b>		1997-04-01
<b>Previous Releases :</b>		11.92, 11.93, 08.94, 08.95, 10.96
<b>Page (previous version)</b>	<b>Page (new version)</b>	<b>Subjects (changes since last revision)</b>
general		C501G-1E OTP version included
4	4	Ordering information resorted and C501G-1E types added
5	5	Table with literature hints added
5-7	5-7	Pin configuration logic symbol for pins $\overline{EA}/V_{pp}$ and $ALE/\overline{PROG}$ updated
11	11	Pin description for $ALE/\overline{PROG}$ and $\overline{EA}/V_{pp}$ completed
8, 9, 10	8, 9, 10	Port 1, 3, 2 pin description: "bidirectional" replaced by "quasi-bidirectional"
13	13	Block diagram updated for C501G-1E
14	14	New design of register (PSW) description
-	15	"Memory organization" added
15-18	16-18	Actualized design of the SFR tables
17	17	Reset value of T2CON corrected
-	25-28	Description for the C501-1E OTP version added
-	31	DC characteristics for C501-1E added
41	41	Timing "External Clock Drive" now behind "Data Memory Cycle"
-	43, 44	AC characteristics for C501-1E added

#### **Edition 1997-04-01**

**Published by Siemens AG,  
Bereich Halbleiter, Marketing-  
Kommunikation, Balanstraße 73,  
81541 München**

© Siemens AG 1997.

All Rights Reserved.

#### **Attention please!**

As far as patents or other rights of third parties are concerned, liability is only assumed for components, not for applications, processes and circuits implemented within components or assemblies.

The information describes the type of component and shall not be considered as assured characteristics.

Terms of delivery and rights to change design reserved.

For questions on technology, delivery and prices please contact the Semiconductor Group Offices in Germany or the Siemens Companies and Representatives worldwide (see address list).

Due to technical requirements components may contain dangerous substances. For information on the types in question please contact your nearest Siemens Office, Semiconductor Group.

Siemens AG is an approved CECC manufacturer.

#### **Packing**

Please use the recycling operators known to you. We can also help you – get in touch with your nearest sales office. By agreement we will take packing material back, if it is sorted. You must bear the costs of transport.

For packing material that is returned to us unsorted or which we are not obliged to accept, we shall have to invoice you for any costs incurred.

#### **Components used in life-support devices or systems must be expressly authorized for such purpose!**

Critical components<sup>1</sup> of the Semiconductor Group of Siemens AG, may only be used in life-support devices or systems<sup>2</sup> with the express written approval of the Semiconductor Group of Siemens AG.

- 1 A critical component is a component used in a life-support device or system whose failure can reasonably be expected to cause the failure of that life-support device or system, or to affect its safety or effectiveness of that device or system.
- 2 Life support devices or systems are intended (a) to be implanted in the human body, or (b) to support and/or maintain and sustain human life. If they fail, it is reasonable to assume that the health of the user may be endangered.

### Preliminary

- Fully compatible to standard 8051 microcontroller
- Versions for 12/24/40 MHz operating frequency
- Program memory : completely external (C501-L)  
8K × 8 ROM (C501-1R)  
8K × 8 OTP memory (C501-1E)
- 256 × 8 RAM
- Four 8-bit ports
- Three 16-bit timers / counters (timer 2 with up/down counter feature)
- USART
- Six interrupt sources, two priority levels
- Power saving modes
- Quick Pulse programming algorithm (C501-1E only)
- 2-Level program memory lock (C501-1E only)
- P-DIP-40, P-LCC-44, and P-MQFP-44 package
- Temperature ranges :   SAB-C501         $T_A$  : 0 °C to 70 °C  
                                  SAF-C501         $T_A$  : - 40 °C to 85 °C

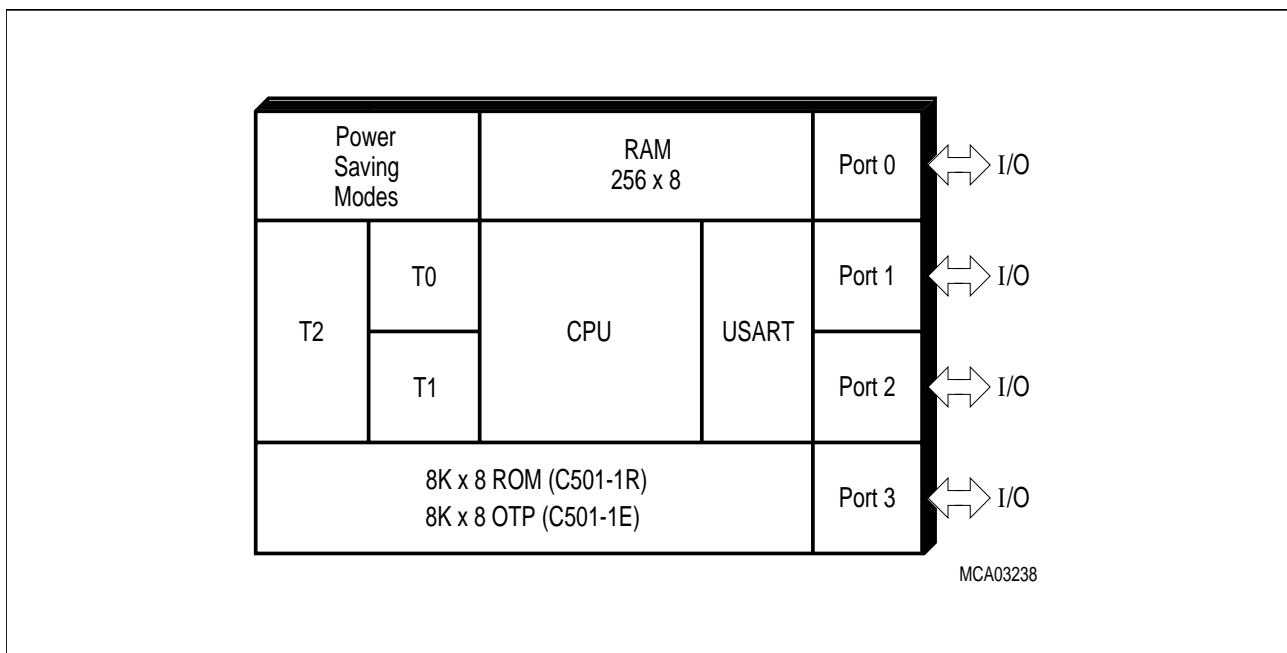

**Figure 1**  
**C501G Functional Units**

The C501-1R contains a non-volatile 8K × 8 read-only program memory, a volatile 256 × 8 read/write data memory, four ports, three 16-bit timers counters, a seven source, two priority level interrupt structure and a serial port. The C501-L is identical, except that it lacks the program memory on chip. The C501-1E contains a one-time programmable (OTP) program memory on chip. The term C501 refers to all versions within this specification unless otherwise noted. Further, the term C501 refers to all versions which are available in the different temperature ranges, marked with SAB-C501... or SAF-C501....

### Ordering Information

Type	Ordering Code	Package	Description (8-Bit CMOS microcontroller)
SAB-C501G-LN SAB-C501G-LP SAB-C501G-LM	Q67120-C969 Q67120-C968 Q67127-C970	P-LCC-44 P-DIP-40 P-MQFP-44	for external memory (12 MHz)
SAB-C501G-L24N SAB-C501G-L24P SAB-C501G-L24M	Q67120-C1001 Q67120-C999 Q67127-C1014	P-LCC-44 P-DIP-40 P-MQFP-44	for external memory (24 MHz)
SAB-C501G-L40N SAB-C501G-L40P SAB-C501G-L40M	Q67120-C1002 Q67120-C1000 Q67127-C1009	P-LCC-44 P-DIP-40 P-MQFP-44	for external memory (40 MHz)
SAF-C501G-L24N SAF-C501G-L24P	Q67120-C1011 Q67120-C1010	P-LCC-44 P-MQFP-44	for external memory (24 MHz) ext. temp. – 40 °C to 85 °C
SAB-C501G-1RN SAB-C501G-1RP SAB-C501G-1RM	Q67120-DXXX Q67120-DXXX Q67127-DXXX	P-LCC-44 P-DIP-40 P-MQFP-44	with mask-programmable ROM (12 MHz)
SAB-C501G-1R24N SAB-C501G-1R24P SAB-C501G-1R24M	Q67120-DXXX Q67120-DXXX Q67127-DXXX	P-LCC-44 P-DIP-40 P-MQFP-44	with mask-programmable ROM (24 MHz)
SAB-C501G-1R40N SAB-C501G-1R40P SAB-C501G-1R40M	Q67120-DXXX Q67120-DXXX Q67127-DXXX	P-LCC-44 P-DIP-40 P-MQFP-44	with mask-programmable ROM (40 MHz)
SAF-C501G-1R24N SAF-C501G-1R24P	Q67120-DXXX Q67120-DXXX	P-LCC-44 P-DIP-40	with mask-programmable ROM (24 MHz) ext. temp. – 40 °C to 85 °C
SAB-C501G-1EN SAB-C501G-1EP	Q67120-C1054 Q67120-C1056	P-LCC-44 P-DIP-40	with OTP memory (12 MHz)
SAF-C501G-1EN SAF-C501G-1EP	Q67120-C2002 Q67120-C2003	P-LCC-44 P-DIP-40	with OTP memory (12 MHz) ext. temp. – 40 °C to 85 °C
SAB-C501G-1E24N SAB-C501G-1E24P	Q67120-C2005 Q67120-C2006	P-LCC-44 P-DIP-40	with OTP memory (24 MHz)
SAF-C501G-1E24N SAF-C501G-1E24P	Q67120-C2008 Q67120-C2009	P-LCC-44 P-DIP-40	with OTP memory (24 MHz) ext. temp. – 40 °C to 85 °C

**Note:** Versions for extended temperature range – 40 °C to 110 °C (SAH-C501G) on request.  
The ordering number of ROM types (DXXX extensions) is defined after program release (verification) of the customer.

### Additional Literature

For further information about the C501 the following literature is available :

Title	Ordering Number
C501 8-Bit CMOS Microcontroller User's Manual	B158-H6723-X-X-7600
C500 Microcontroller Family Architecture and Instruction Set User's Manual	B158-H6987-X-X-7600
C500 Microcontroller Family - Pocket Guide	B158-H6986-X-X-7600

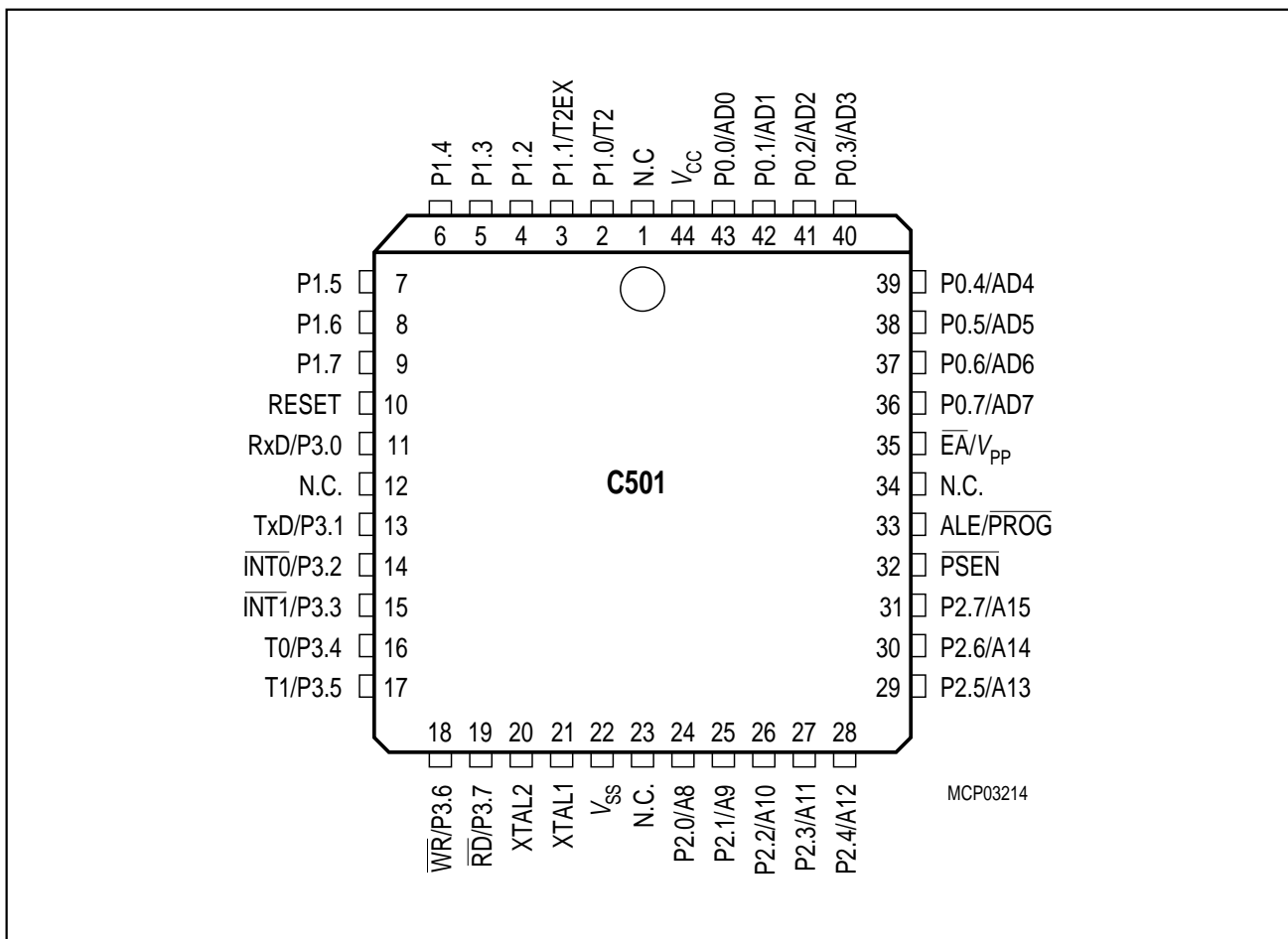

**Figure 2**  
**Pin Configuration P-LCC-44 Package (Top view)**

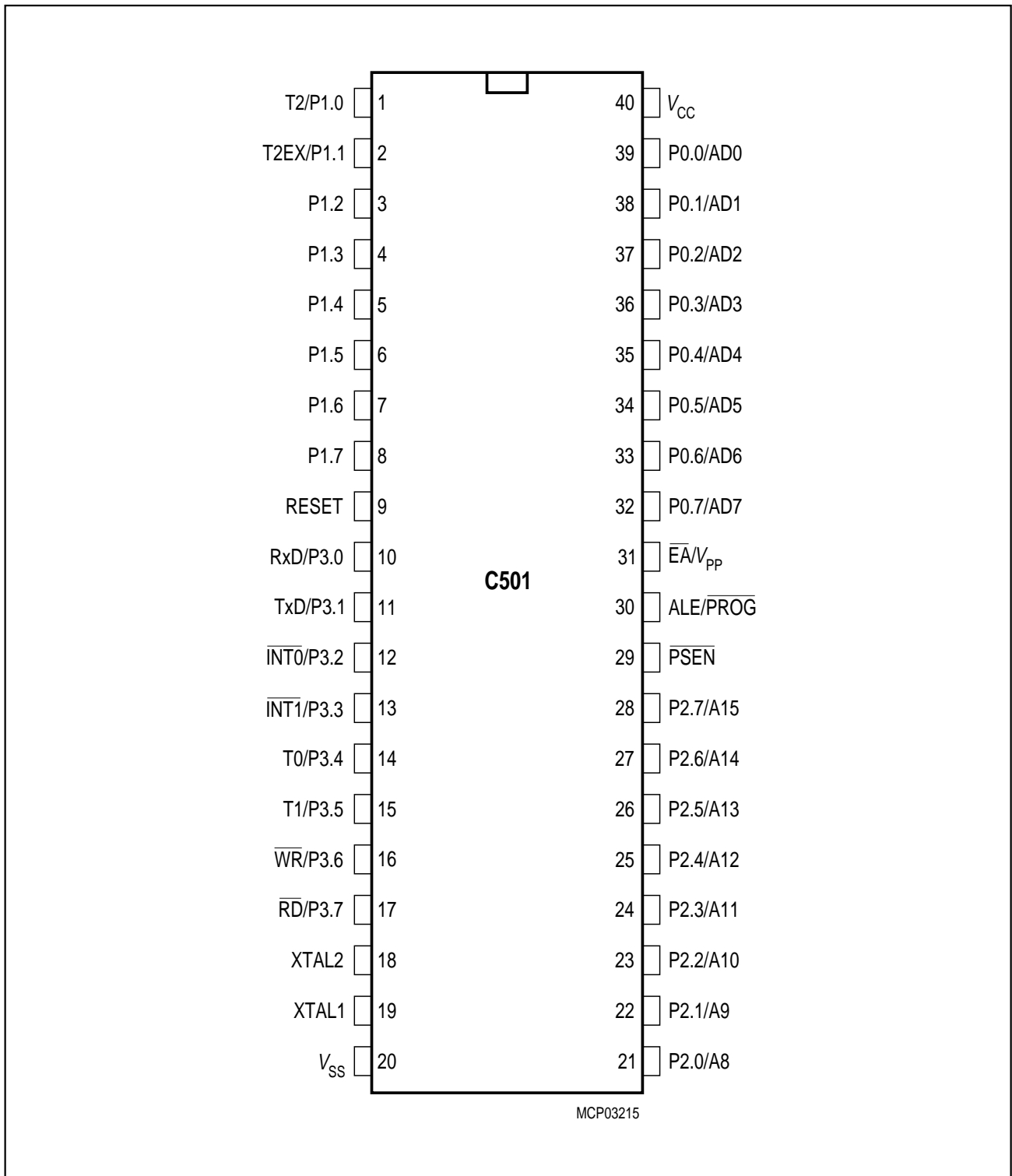

**Figure 3**  
**Pin Configuration P-DIP-40 Package (top view)**

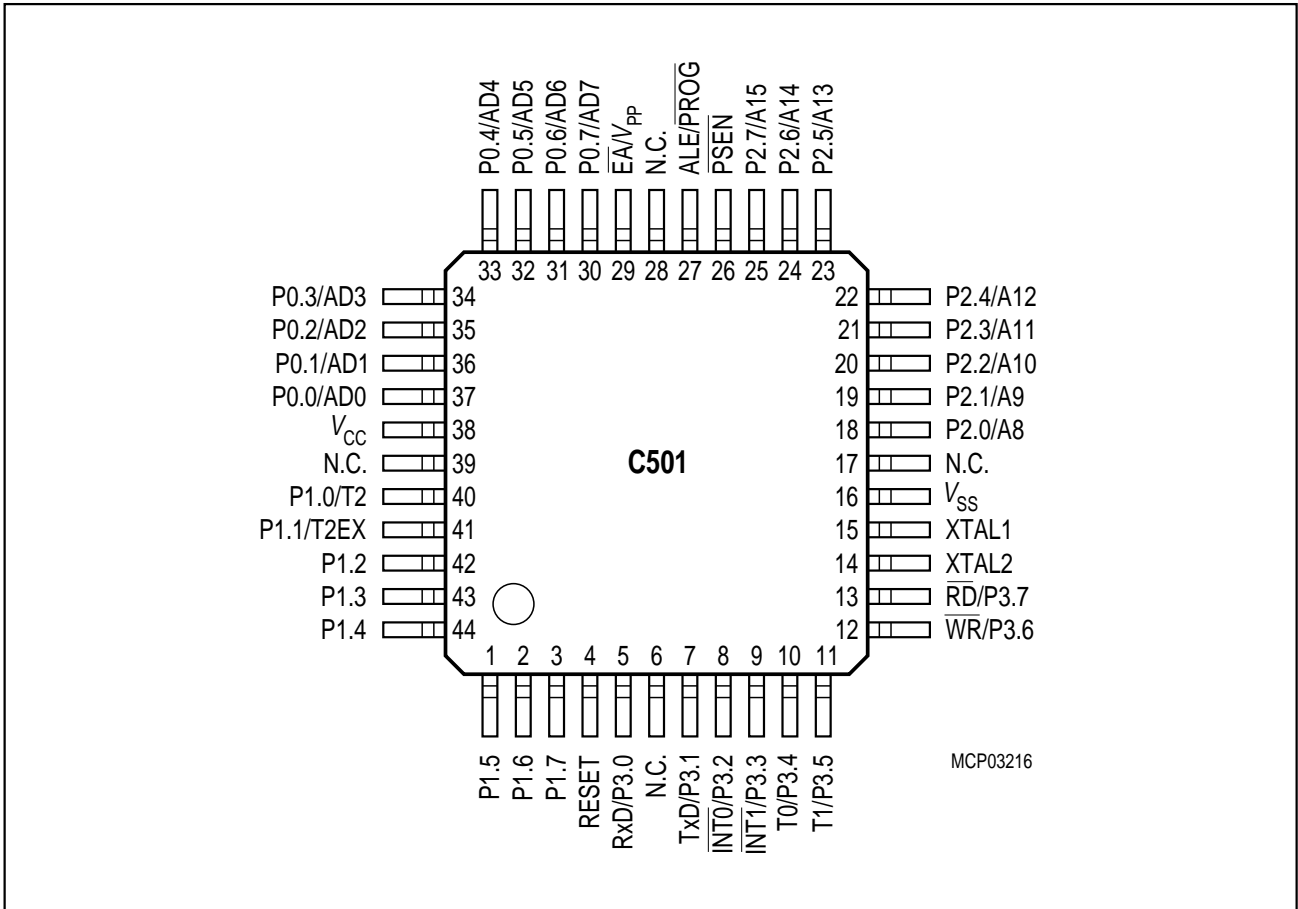

**Figure 4**  
Pin Configuration P-MQFP-44 Package (top view)

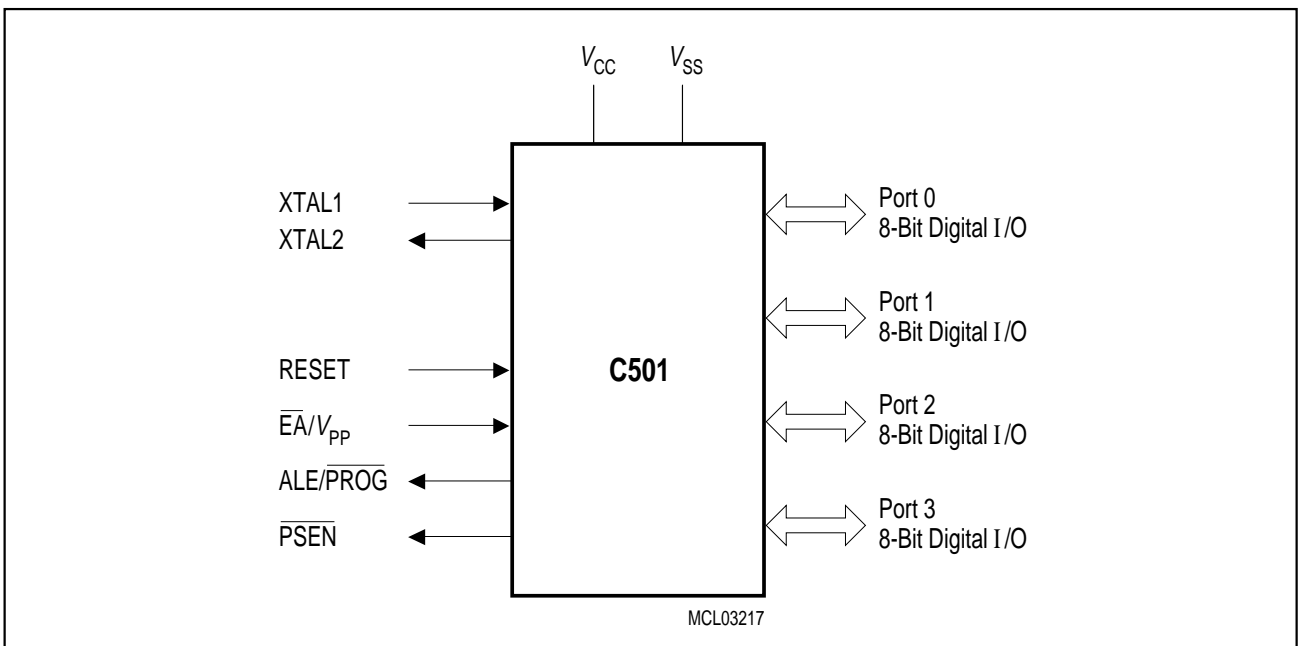

**Figure 5**  
Logic Symbol

**Table 1**  
**Pin Definitions and Functions**

Symbol	Pin Number			I/O*)	Function
	P-LCC-44	P-DIP-40	P-MQFP-44		
P1.0 – P1.7	2–9	1–8	40–44, 1–3,	I/O	<p><b>Port 1</b> is a quasi-bidirectional I/O port with internal pull-up resistors. Port 1 pins that have 1s written to them are pulled high by the internal pullup resistors, and in that state can be used as inputs. As inputs, port 1 pins being externally pulled low will source current (<math>I_{IL}</math>, in the DC characteristics) because of the internal pull-up resistors. Port 1 also contains the timer 2 pins as secondary function. The output latch corresponding to a secondary function must be programmed to a one (1) for that function to operate. The secondary functions are assigned to the pins of port 1, as follows:</p> <p>P1.0 T2 Input to counter 2 P1.1 T2EX Capture - Reload trigger of timer 2 / Up-Down count</p>
	2 3	1 2	40 41		

\*) I = Input  
O = Output



**Table 1**  
**Pin Definitions and Functions (cont'd)**

Symbol	Pin Number			I/O*)	Function
	P-LCC-44	P-DIP-40	P-MQFP-44		
P3.0 – P3.7	11, 13–19	10–17	5, 7–13	I/O	<p><b>Port 3</b> is a quasi-bidirectional I/O port with internal pull-up resistors. Port 3 pins that have 1s written to them are pulled high by the internal pull-up resistors, and in that state they can be used as inputs. As inputs, port 3 pins being externally pulled low will source current (<math>I_{IL}</math>, in the DC characteristics) because of the internal pull-up resistors. Port 3 also contains the interrupt, timer, serial port 0 and external memory strobe pins which are used by various options. The output latch corresponding to a secondary function must be programmed to a one (1) for that function to operate. The secondary functions are assigned to the pins of port 3, as follows:</p> <p>P3.0 RxD receiver data input (asynchronous) or data input output (synchronous) of serial interface 0</p> <p>P3.1 TxD transmitter data output (asynchronous) or clock output (synchronous) of the serial interface 0</p> <p>P3.2 <math>\overline{INT0}</math> interrupt 0 input/timer 0 gate control</p> <p>P3.3 <math>\overline{INT1}</math> interrupt 1 input/timer 1 gate control</p> <p>P3.4 T0 counter 0 input</p> <p>P3.5 T1 counter 1 input</p> <p>P3.6 <math>\overline{WR}</math> the write control signal latches the data byte from port 0 into the external data memory</p> <p>P3.7 <math>\overline{RD}</math> the read control signal enables the external data memory to port 0</p>
	11	10	5		
	13	11	7		
	14	12	8		
	15	13	9		
	16	14	10		
	17	15	11		
	18	16	12		
	19	17	13		

\*) I = Input  
O = Output

**Table 1**  
**Pin Definitions and Functions (cont'd)**

Symbol	Pin Number			I/O*)	Function
	P-LCC-44	P-DIP-40	P-MQFP-44		
XTAL2	20	18	14	–	<b>XTAL2</b> Output of the inverting oscillator amplifier.
XTAL1	21	19	15	–	<b>XTAL1</b> Input to the inverting oscillator amplifier and input to the internal clock generator circuits. To drive the device from an external clock source, XTAL1 should be driven, while XTAL2 is left unconnected. There are no requirements on the duty cycle of the external clock signal, since the input to the internal clocking circuitry is divided down by a divide-by-two flip-flop. Minimum and maximum high and low times as well as rise fall times specified in the AC characteristics must be observed.
P2.0 – P2.7	24–31	21–28	18–25	I/O	<b>Port 2</b> is a quasi-bidirectional I/O port with internal pull-up resistors. Port 2 pins that have 1s written to them are pulled high by the internal pull-up resistors, and in that state they can be used as inputs. As inputs, port 2 pins being externally pulled low will source current ( $I_{IL}$ , in the DC characteristics) because of the internal pull-up resistors. Port 2 emits the high-order address byte during fetches from external program memory and during accesses to external data memory that use 16-bit addresses (MOVX @DPTR). In this application it uses strong internal pull-up resistors when issuing 1s. During accesses to external data memory that use 8-bit addresses (MOVX @Ri), port 2 issues the contents of the P2 special function register.

\*) I = Input  
O = Output

**Table 1**  
**Pin Definitions and Functions (cont'd)**

Symbol	Pin Number			I/O*)	Function
	P-LCC-44	P-DIP-40	P-MQFP-44		
$\overline{\text{PSEN}}$	32	29	26	O	<b>The Program Store Enable</b> output is a control signal that enables the external program memory to the bus during external fetch operations. It is activated every six oscillator periods except during external data memory accesses. Remains high during internal program execution.
RESET	10	9	4	I	<b>RESET</b> A high level on this pin for two machine cycles while the oscillator is running resets the device. An internal diffused resistor to $V_{SS}$ permits power-on reset using only an external capacitor to $V_{CC}$ .
$\overline{\text{ALE/PROG}}$	33	30	27	I/O	<b>The Address Latch Enable</b> output is used for latching the low-byte of the address into external memory during normal operation. It is activated every six oscillator periods except during an external data memory access. For the C501-1E this pin is also the program pulse input (PROG) during OTP memory programming.
$\overline{\text{EA/V}}_{PP}$	35	31	29	I	<b>External Access Enable</b> When held at high level, instructions are fetched from the internal ROM (C501-1R and C501-1E) when the PC is less than $2000_{\text{H}}$ . When held at low level, the C501 fetches all instructions from external program memory. For the C501-L this pin must be tied low. This pin also receives the programming supply voltage $V_{PP}$ during OTP memory programming (C501-1E) only).

\*) I = Input  
 O = Output

**Table 1**  
**Pin Definitions and Functions (cont'd)**

Symbol	Pin Number			I/O*)	Function
	P-LCC-44	P-DIP-40	P-MQFP-44		
P0.0 – P0.7	43–36	39–32	37–30	I/O	<p><b>Port 0</b>  is an 8-bit open-drain bidirectional I/O port. Port 0 pins that have 1s written to them float, and in that state can be used as high-impedance inputs. Port 0 is also the multiplexed low-order address and data bus during accesses to external program or data memory. In this application it uses strong internal pull-up resistors when issuing 1s.  Port 0 also outputs the code bytes during program verification in the C501-1R and C501-1E. External pull-up resistors are required during program verification.</p>
$V_{SS}$	22	20	16	–	<b>Circuit ground potential</b>
$V_{CC}$	44	40	38	–	<b>Supply terminal</b> for all operating modes
N.C.	1, 12, 23, 34	–	6, 17, 28, 39	–	<b>No connection</b>

\*) I = Input  
O = Output

**Functional Description**

The C501 is fully compatible to the standard 8051 microcontroller family.

It is compatible with the 80C32/52/82C52. While maintaining all architectural and operational characteristics of the 8051 microcontroller family, the C501 incorporates some enhancements in the timer 2 unit.

**Figure 6** shows a block diagram of the C501.

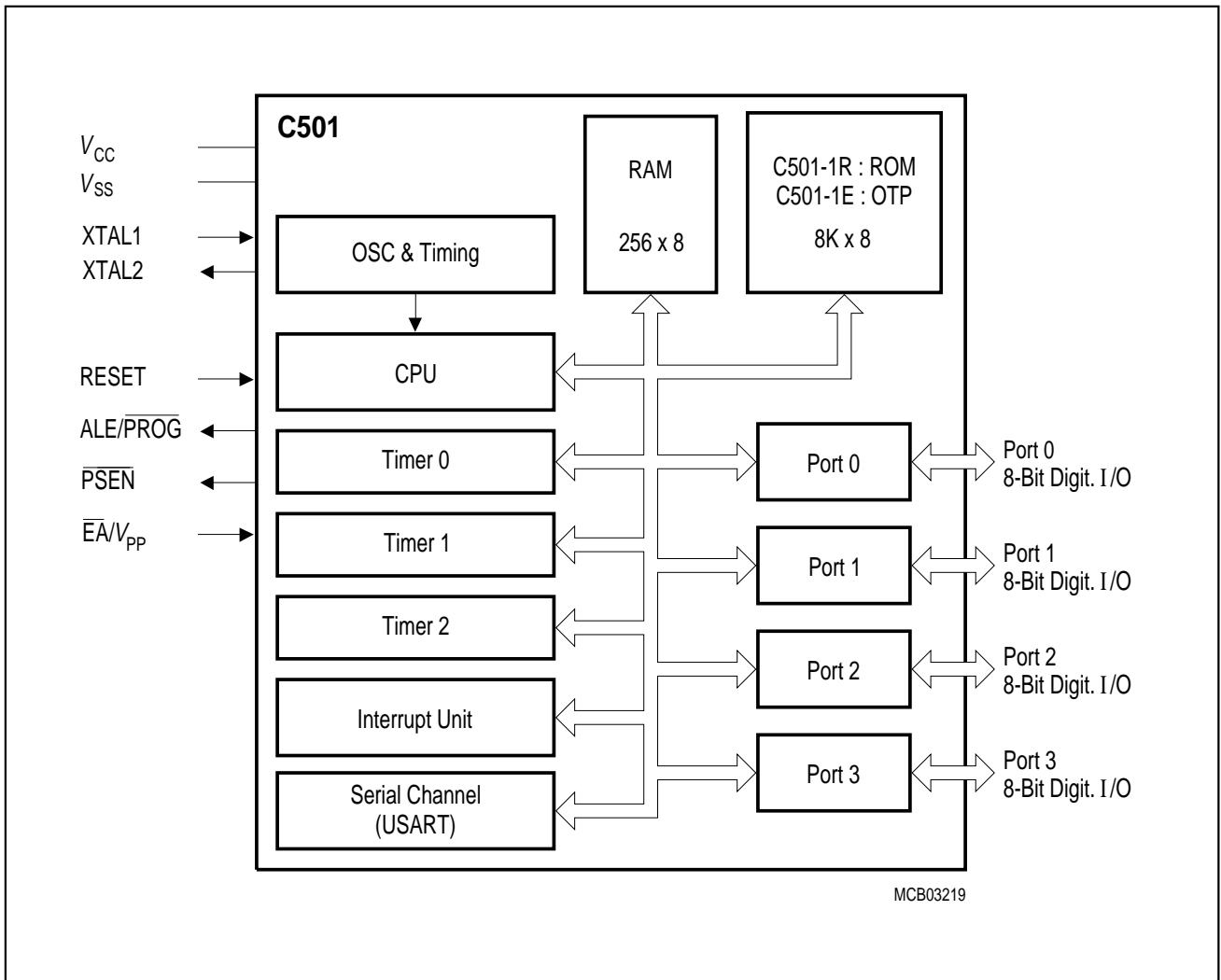

**Figure 6**  
**Block Diagram of the C501**

## CPU

The C501 is efficient both as a controller and as an arithmetic processor. It has extensive facilities for binary and BCD arithmetic and excels in its bit-handling capabilities. Efficient use of program memory results from an instruction set consisting of 44 % one-byte, 41 % two-byte, and 15% three-byte instructions. With a 12 MHz crystal, 58% of the instructions are executed in 1.0  $\mu$ s (24 MHz: 500 ns, 40 MHz : 300 ns).

### Special Function Register PSW (Address D0<sub>H</sub>)

Reset Value : 00<sub>H</sub>

Bit No.	MSB								LSB
	D7 <sub>H</sub>	D6 <sub>H</sub>	D5 <sub>H</sub>	D4 <sub>H</sub>	D3 <sub>H</sub>	D2 <sub>H</sub>	D1 <sub>H</sub>	D0 <sub>H</sub>	
D0 <sub>H</sub>	CY	AC	F0	RS1	RS0	OV	F1	P	PSW

Bit	Function															
CY	Carry Flag Used by arithmetic instruction.															
AC	Auxiliary Carry Flag Used by instructions which execute BCD operations.															
F0	General Purpose Flag															
RS1 RS0	Register Bank select control bits These bits are used to select one of the four register banks.															
	<table border="1" style="width: 100%; border-collapse: collapse;"> <thead> <tr> <th style="text-align: center;">RS1</th> <th style="text-align: center;">RS0</th> <th style="text-align: left;">Function</th> </tr> </thead> <tbody> <tr> <td style="text-align: center;">0</td> <td style="text-align: center;">0</td> <td>Bank 0 selected, data address 00<sub>H</sub>-07<sub>H</sub></td> </tr> <tr> <td style="text-align: center;">0</td> <td style="text-align: center;">1</td> <td>Bank 1 selected, data address 08<sub>H</sub>-0F<sub>H</sub></td> </tr> <tr> <td style="text-align: center;">1</td> <td style="text-align: center;">0</td> <td>Bank 2 selected, data address 10<sub>H</sub>-17<sub>H</sub></td> </tr> <tr> <td style="text-align: center;">1</td> <td style="text-align: center;">1</td> <td>Bank 3 selected, data address 18<sub>H</sub>-1F<sub>H</sub></td> </tr> </tbody> </table>	RS1	RS0	Function	0	0	Bank 0 selected, data address 00 <sub>H</sub> -07 <sub>H</sub>	0	1	Bank 1 selected, data address 08 <sub>H</sub> -0F <sub>H</sub>	1	0	Bank 2 selected, data address 10 <sub>H</sub> -17 <sub>H</sub>	1	1	Bank 3 selected, data address 18 <sub>H</sub> -1F <sub>H</sub>
RS1	RS0	Function														
0	0	Bank 0 selected, data address 00 <sub>H</sub> -07 <sub>H</sub>														
0	1	Bank 1 selected, data address 08 <sub>H</sub> -0F <sub>H</sub>														
1	0	Bank 2 selected, data address 10 <sub>H</sub> -17 <sub>H</sub>														
1	1	Bank 3 selected, data address 18 <sub>H</sub> -1F <sub>H</sub>														
OV	Overflow Flag Used by arithmetic instruction.															
F1	General Purpose Flag															
P	Parity Flag Set/cleared by hardware after each instruction to indicate an odd/even number of "one" bits in the accumulator, i.e. even parity.															

## Memory Organization

The C501 CPU manipulates data and operands in the following four address spaces:

- up to 64 Kbyte of internal/external program memory
- up to 64 Kbyte of external data memory
- 256 bytes of internal data memory
- a 128 byte special function register area

Figure 7 illustrates the memory address spaces of the C501.

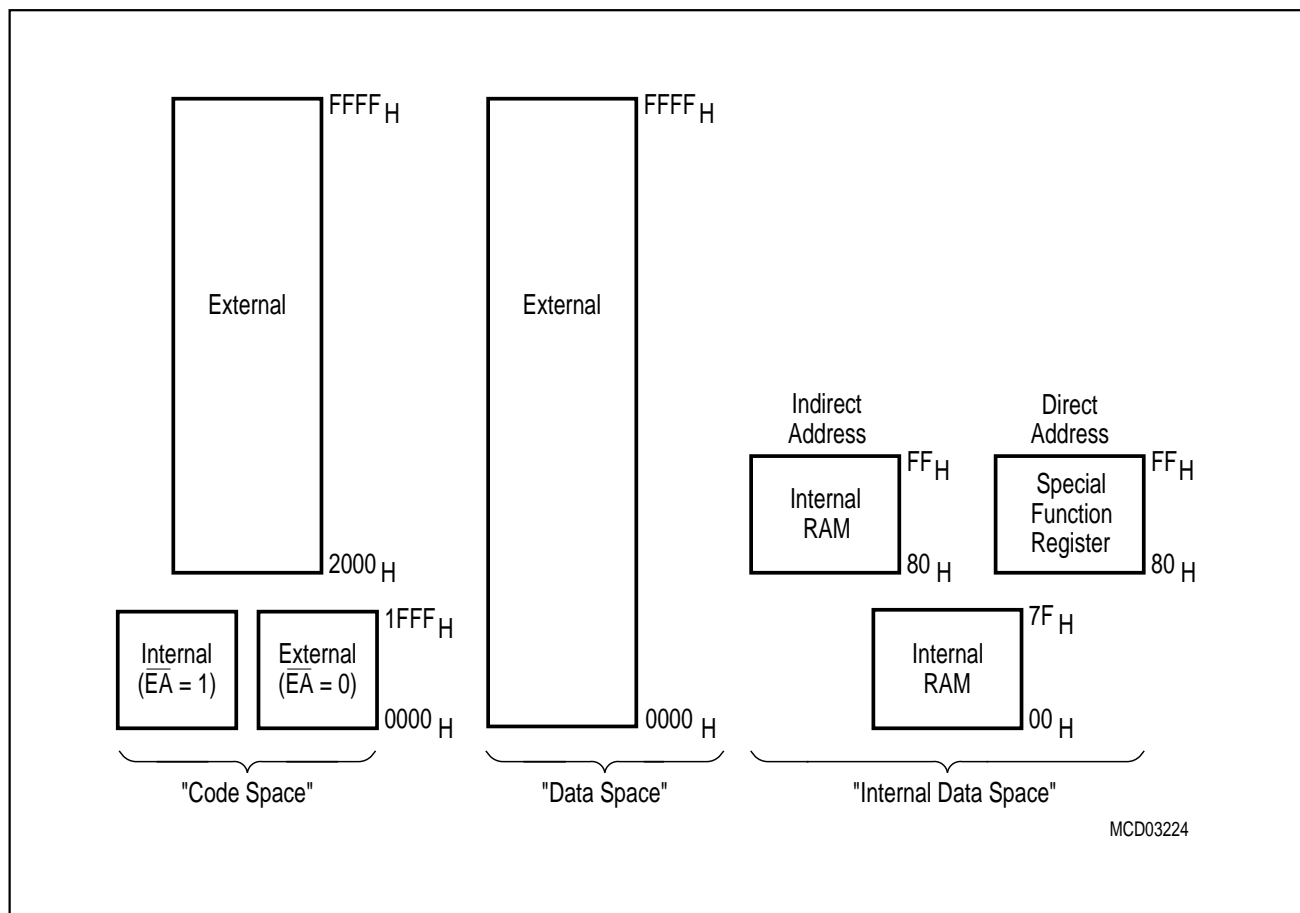

**Figure 7**  
**C501 Memory Map**

### Special Function Registers

The registers, except the program counter and the four general purpose register banks, reside in the special function register area.

The 27 special function registers (SFRs) include pointers and registers that provide an interface between the CPU and the other on-chip peripherals. All SFRs with addresses where address bits 0-2 are 0 (e.g. 80<sub>H</sub>, 88<sub>H</sub>, 90<sub>H</sub>, 98<sub>H</sub>, ..., F8<sub>H</sub>, FF<sub>H</sub>) are bitaddressable.

The SFRs of the C501 are listed in **table 2** and **table 3**. In **table 2** they are organized in groups which refer to the functional blocks of the C501. **Table 3** illustrates the contents of the SFRs in numeric order of their addresses.



**Table 2**  
**Special Function Registers - Functional Blocks**

Block	Symbol	Name	Address	Contents after Reset
CPU	ACC	Accumulator	<b>E0H</b> <sup>1)</sup>	00H
	B	B-Register	<b>F0H</b> <sup>1)</sup>	00H
	DPH	Data Pointer, High Byte	83H	00H
	DPL	Data Pointer, Low Byte	82H	00H
	PSW	Program Status Word Register	<b>D0H</b> <sup>1)</sup>	00H
	SP	Stack Pointer	81H	07H
Interrupt System	IE	Interrupt Enable Register	<b>A8H</b> <sup>1)</sup>	0X000000B <sup>3)</sup>
	IP	Interrupt Priority Register	<b>B8H</b> <sup>1)</sup>	XX000000B <sup>3)</sup>
Ports	P0	Port 0	<b>80H</b> <sup>1)</sup>	FFH
	P1	Port 1	<b>90H</b> <sup>1)</sup>	FFH
	P2	Port 2	<b>A0H</b> <sup>1)</sup>	FFH
	P3	Port 3	<b>B0H</b> <sup>1)</sup>	FFH
Serial Channel	PCON <sup>2)</sup>	Power Control Register	87H	0XXX0000B <sup>3)</sup>
	SBUF	Serial Channel Buffer Register	99H	XXH <sup>3)</sup>
	SCON	Serial Channel Control Register	<b>98H</b> <sup>1)</sup>	00H
Timer 0 / Timer 1	TCON	Timer 0/1 Control Register	<b>88H</b> <sup>1)</sup>	00H
	TH0	Timer 0, High Byte	8CH	00H
	TH1	Timer 1, High Byte	8DH	00H
	TL0	Timer 0, Low Byte	8AH	00H
	TL1	Timer 1, Low Byte	8BH	00H
	TMOD	Timer Mode Register	89H	00H
Timer 2	T2CON	Timer 2 Control Register	<b>C8H</b> <sup>1)</sup>	00H
	T2MOD	Timer 2 Mode Register	C9H	XXXXXXXX0B <sup>3)</sup>
	RC2H	Timer 2 Reload/Capture Register, High Byte	CBH	00H
	RC2L	Timer 2 Reload/Capture Register, Low Byte	CAH	00H
	TH2	Timer 2 High Byte	CDH	00H
	TL2	Timer 2 Low Byte	CCH	00H
	Pow. Sav. Modes	PCON <sup>2)</sup>	Power Control Register	87H

1) Bit-addressable special function registers

2) This special function register is listed repeatedly since some bits of it also belong to other functional blocks.

3) "X" means that the value is undefined and the location is reserved

**Table 3**  
**Contents of the SFRs, SFRs in numeric order of their addresses**

Addr	Register	Content after Reset <sup>1)</sup>	Bit 7	Bit 6	Bit 5	Bit 4	Bit 3	Bit 2	Bit 1	Bit 0
80 <sub>H</sub> <sup>2)</sup>	P0	FF <sub>H</sub>	.7	.6	.5	.4	.3	.2	.1	.0
81 <sub>H</sub>	SP	07 <sub>H</sub>	.7	.6	.5	.4	.3	.2	.1	.0
82 <sub>H</sub>	DPL	00 <sub>H</sub>	.7	.6	.5	.4	.3	.2	.1	.0
83 <sub>H</sub>	DPH	00 <sub>H</sub>	.7	.6	.5	.4	.3	.2	.1	.0
87 <sub>H</sub>	PCON	0XXX-0000 <sub>B</sub>	SMOD	–	–	–	GF1	GF0	PDE	IDLE
88 <sub>H</sub> <sup>2)</sup>	TCON	00 <sub>H</sub>	TF1	TR1	TF0	TR0	IE1	IT1	IE0	IT0
89 <sub>H</sub>	TMOD	00 <sub>H</sub>	GATE	C/ $\bar{T}$	M1	M0	GATE	C/ $\bar{T}$	M1	M0
8A <sub>H</sub>	TL0	00 <sub>H</sub>	.7	.6	.5	.4	.3	.2	.1	.0
8B <sub>H</sub>	TL1	00 <sub>H</sub>	.7	.6	.5	.4	.3	.2	.1	.0
8C <sub>H</sub>	TH0	00 <sub>H</sub>	.7	.6	.5	.4	.3	.2	.1	.0
8D <sub>H</sub>	TH1	00 <sub>H</sub>	.7	.6	.5	.4	.3	.2	.1	.0
90 <sub>H</sub> <sup>2)</sup>	P1	FF <sub>H</sub>	.7	.6	.5	.4	.3	.2	.1	.0
98 <sub>H</sub> <sup>2)</sup>	SCON	00 <sub>H</sub>	SM0	SM1	SM2	REN	TB8	RB8	TI	RI
99 <sub>H</sub>	SBUF	XX <sub>H</sub>	.7	.6	.5	.4	.3	.2	.1	.0
A0 <sub>H</sub> <sup>2)</sup>	P2	FF <sub>H</sub>	.7	.6	.5	.4	.3	.2	.1	.0
A8 <sub>H</sub> <sup>2)</sup>	IE	0X00-0000 <sub>B</sub>	EA	–	ET2	ES	ET1	EX1	ET0	EX0
B0 <sub>H</sub> <sup>2)</sup>	P3	FF <sub>H</sub>	RD	WR	T1	T0	INT1	INT0	TxD	RxD
B8 <sub>H</sub> <sup>2)</sup>	IP	XX00.0000 <sub>B</sub>	–	–	PT2	PS	PT1	PX1	PT0	PX0
C8 <sub>H</sub> <sup>2)</sup>	T2CON	00 <sub>H</sub>	TF2	EXF2	RCLK	TCLK	EXEN2	TR2	C/ $\bar{T}2$	CP/ $\bar{R}L2$
C9 <sub>H</sub>	T2MOD	XXXX-XXX0 <sub>B</sub>	–	–	–	–	–	–	–	DCEN
CA <sub>H</sub>	RC2L	00 <sub>H</sub>	.7	.6	.5	.4	.3	.2	.1	.0
CB <sub>H</sub>	RC2H	00 <sub>H</sub>	.7	.6	.5	.4	.3	.2	.1	.0
CC <sub>H</sub>	TL2	00 <sub>H</sub>	.7	.6	.5	.4	.3	.2	.1	.0
CD <sub>H</sub>	TH2	00 <sub>H</sub>	.7	.6	.5	.4	.3	.2	.1	.0
D0 <sub>H</sub> <sup>2)</sup>	PSW	00 <sub>H</sub>	CY	AC	F0	RS1	RS0	OV	F1	P
E0 <sub>H</sub> <sup>2)</sup>	ACC	00 <sub>H</sub>	.7	.6	.5	.4	.3	.2	.1	.0
F0 <sub>H</sub> <sup>2)</sup>	B	00 <sub>H</sub>	.7	.6	.5	.4	.3	.2	.1	.0

1) X means that the value is undefined and the location is reserved

2) Bit-addressable special function registers

## Timer / Counter 0 and 1

Timer/counter 0 and 1 can be used in four operating modes as listed in **table 4**.

**Table 4**  
**Timer/Counter 0 and 1 Operating Modes**

Mode	Description	TMOD				Input Clock	
		Gate	C/T	M1	M0	internal	external (max)
0	8-bit timer/counter with a divide-by-32 prescaler	X	X	0	0	$f_{osc}/12 \times 32$	$f_{osc}/24 \times 32$
1	16-bit timer/counter	X	X	1	1	$f_{osc}/12$	$f_{osc}/24$
2	8-bit timer/counter with 8-bit autoreload	X	X	0	0	$f_{osc}/12$	$f_{osc}/24$
3	Timer/counter 0 used as one 8-bit timer/counter and one 8-bit timer Timer 1 stops	X	X	1	1	$f_{osc}/12$	$f_{osc}/24$

In the “timer” function ( $C/\bar{T} = '0'$ ) the register is incremented every machine cycle. Therefore the count rate is  $f_{osc}/12$ .

In the “counter” function the register is incremented in response to a 1-to-0 transition at its corresponding external input pin (P3.4/T0, P3.5/T1). Since it takes two machine cycles to detect a falling edge the max. count rate is  $f_{osc}/24$ . External inputs  $\overline{INT0}$  and  $\overline{INT1}$  (P3.2, P3.3) can be programmed to function as a gate to facilitate pulse width measurements. **Figure 8** illustrates the input clock logic.

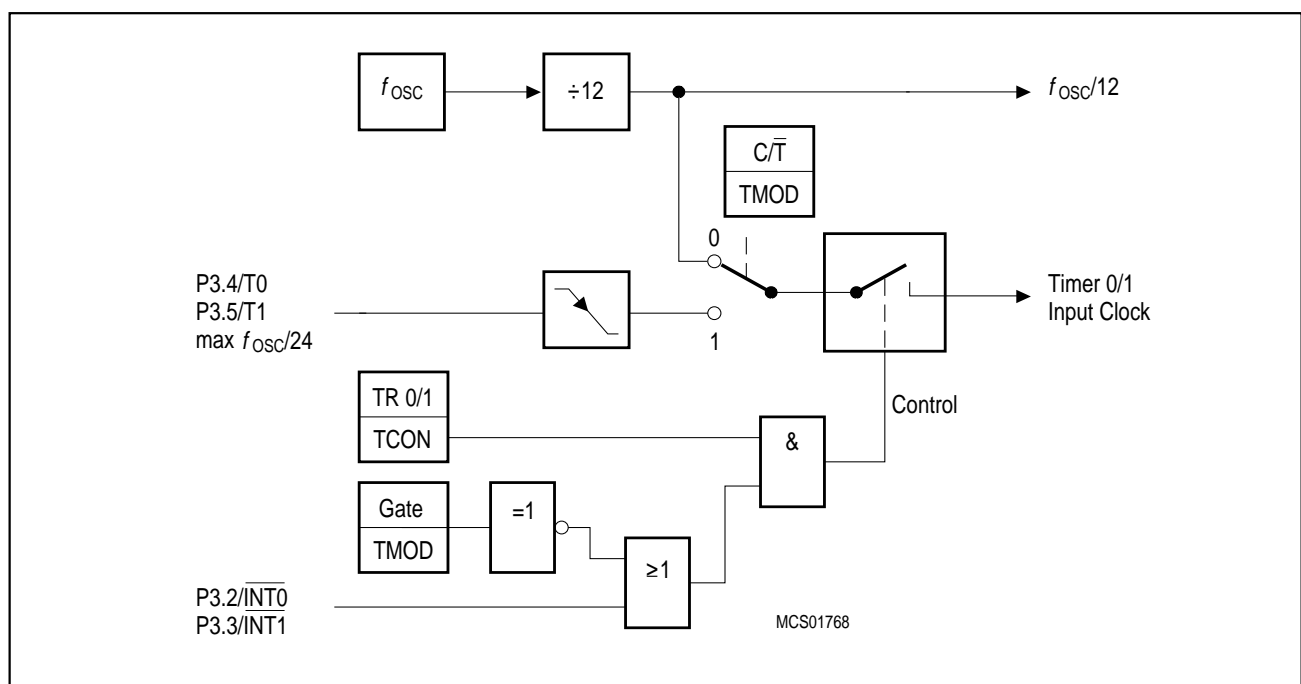

**Figure 8**  
**Timer/Counter 0 and 1 Input Clock Logic**

## Timer 2

Timer 2 is a 16-bit timer/counter with an up/down count feature. It can operate either as timer or as an event counter which is selected by bit  $C/\overline{T2}$  (T2CON.1). It has three operating modes as shown in table 5.

**Table 5**  
**Timer/Counter 2 Operating Modes**

Mode	T2CON			T2MOD DCEN	T2CON EXEN	P1.1/ T2EX	Remarks	Input Clock	
	R×CLK or T×CLK	CP/ RL2	TR2					internal	external (P1.0/T2)
16-bit Auto- reload	0	0	1	0	0	X	reload upon overflow	$f_{osc}/12$	max $f_{osc}/24$
	0	0	1	0	1	↓	reload trigger (falling edge)		
	0	0	1	1	X	0	Down counting		
	0	0	1	1	X	1	Up counting		
16-bit Cap- ture	0	1	1	X	0	X	16 bit Timer/Counter (only up-counting)	$f_{osc}/12$	max $f_{osc}/24$
	0	1	1	X	1	↓	capture TH2, TL2 → RC2H, RC2L		
Baud Rate Gene- rator	1	X	1	X	0	X	no overflow interrupt request (TF2)	$f_{osc}/2$	max $f_{osc}/24$
	1	X	1	X	1	↓	extra external interrupt ("Timer 2")		
off	X	X	0	X	X	X	Timer 2 stops	–	–

**Note:** ↓ =  falling edge

## Serial Interface (USART)

The serial port is full duplex and can operate in four modes (one synchronous mode, three asynchronous modes) as illustrated in **table 6**. The possible baudrates can be calculated using the formulas given in **table 7**.

**Table 6**  
**USART Operating Modes**

Mode	SCON		Baudrate	Description
	SM0	SM1		
0	0	0	$f_{osc}/12$	Serial data enters and exits through RxD. TxD outputs the shift clock. 8-bit are transmitted/received (LSB first)
1	0	1	Timer 1/2 overflow rate	8-bit UART 10 bits are transmitted (through TxD) or received (RxD)
2	1	0	$f_{osc}/32$ or $f_{osc}/64$	9-bit UART 11 bits are transmitted (TxD) or received (RxD)
3	1	1	Timer 1/2 overflow rate	9-bit UART Like mode 2 except the variable baud rate

**Table 7**  
**Formulas for Calculating Baudrates**

Baud Rate derived from	Interface Mode	Baudrate
Oscillator	0 2	$f_{osc}/12$ $(2^{SMOD} \times f_{osc}) / 64$
Timer 1 (16-bit timer) (8-bit timer with 8-bit autoreload)	1,3 1,3	$(2^{SMOD} \times \text{timer 1 overflow rate}) / 32$ $(2^{SMOD} \times f_{osc}) / (32 \times 12 \times (256 - TH1))$
Timer 2	1,3	$f_{osc} / (32 \times (65536 - (RC2H, RC2L)))$

**Interrupt System**

The C501 provides 6 interrupt sources with two priority levels. **Figure 9** gives a general overview of the interrupt sources and illustrates the request and control flags.

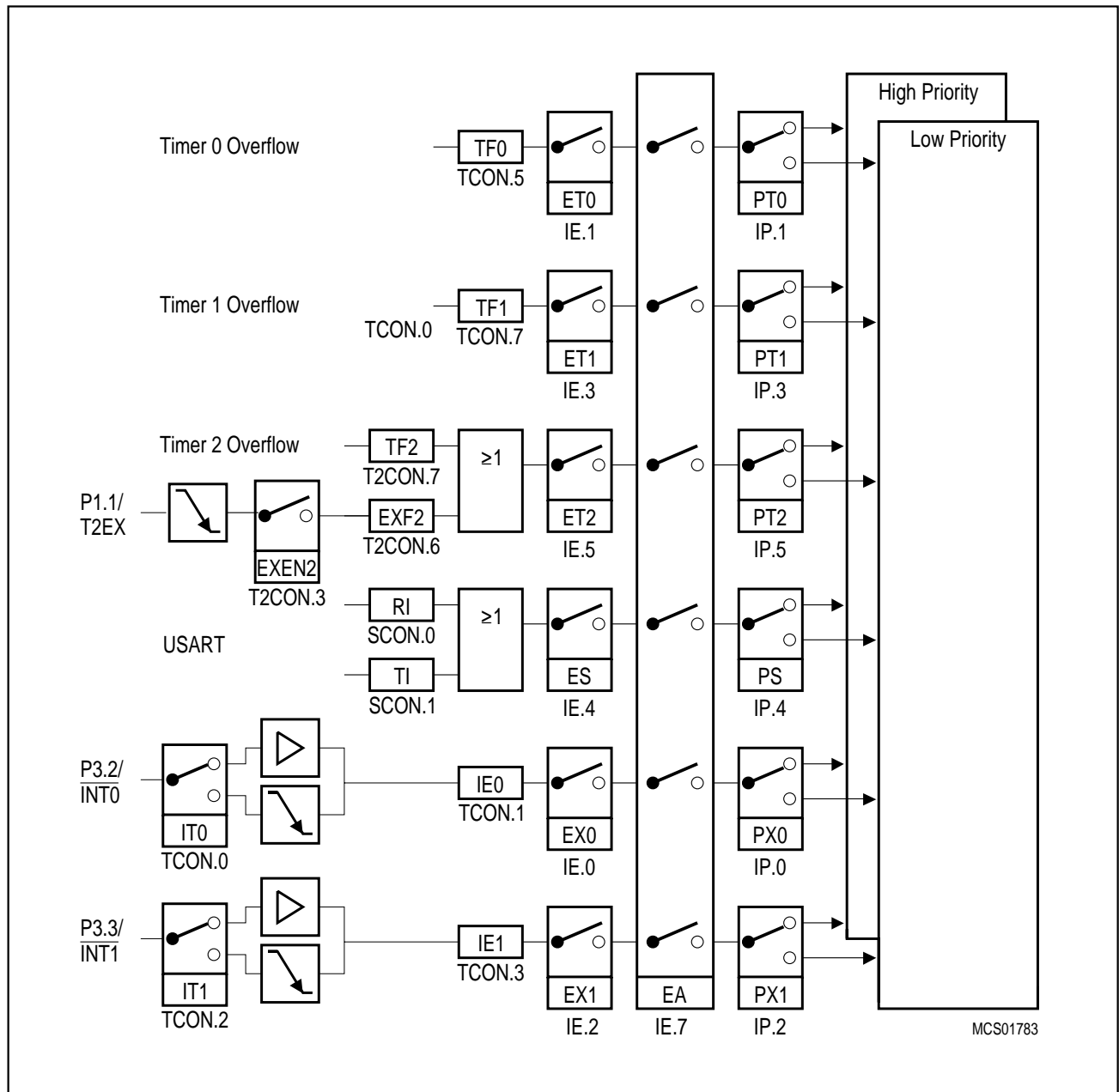

**Figure 9**  
**Interrupt Request Sources**

**Table 8**  
**Interrupt Sources and their Corresponding Interrupt Vectors**

Source (Request Flags)	Vector	Vector Address
IE0	External interrupt 0	0003 <sub>H</sub>
TF0	Timer 0 interrupt	000B <sub>H</sub>
IE1	External interrupt 1	0013 <sub>H</sub>
TF1	Timer 1 interrupt	001B <sub>H</sub>
RI + TI	Serial port interrupt	0023 <sub>H</sub>
TF2 + EXF2	Timer 2 interrupt	002B <sub>H</sub>

A low-priority interrupt can itself be interrupted by a high-priority interrupt, but not by another low-priority interrupt. A high-priority interrupt cannot be interrupted by any other interrupt source.

If two requests of different priority level are received simultaneously, the request of higher priority is serviced. If requests of the same priority are received simultaneously, an internal polling sequence determines which request is serviced. Thus within each priority level there is a second priority structure determined by the polling sequence as shown in **table 9**.

**Table 9**  
**Interrupt Priority-Within-Level**

Interrupt Source	Priority
External Interrupt 0, Timer 0 Interrupt,	High
External Interrupt 1, Timer 1 Interrupt,	↓
Serial Channel, Timer 2 Interrupt,	Low

## Power Saving Modes

Two power down modes are available, the Idle Mode and Power Down Mode.

The bits PDE and IDLE of the register PCON select the Power Down mode or the Idle mode, respectively. If the Power Down mode and the Idle mode are set at the same time, the Power Down mode takes precedence. **Table 10** gives a general overview of the power saving modes.

**Table 10**  
**Power Saving Modes Overview**

Mode	Entering Instruction Example	Leaving by	Remarks
Idle mode	ORL PCON, #01H	– enabled interrupt – Hardware Reset	CPU is gated off CPU status registers maintain their data. Peripherals are active
Power-Down Mode	ORL PCON, #02H	Hardware Reset	Oscillator is stopped, contents of on-chip RAM and SFR's are maintained (leaving Power Down Mode means redefinition of SFR contents).

In the Power Down mode of operation,  $V_{CC}$  can be reduced to minimize power consumption. It must be ensured, however, that  $V_{CC}$  is not reduced before the Power Down mode is invoked, and that  $V_{CC}$  is restored to its normal operating level, before the Power Down mode is terminated. The reset signal that terminates the Power Down mode also restarts the oscillator. The reset should not be activated before  $V_{CC}$  is restored to its normal operating level and must be held active long enough to allow the oscillator to restart and stabilize (similar to power-on reset).



## OTP Operation

The C501-1E is programmed by using a modified Quick-Pulse Programming™<sup>1)</sup> algorithm. It differs from older methods in the value used for  $V_{PP}$  (programming supply voltage) and in the width and number of the ALE/ $\overline{PROG}$  pulses. The C501-1E contains two signature bytes that can be read and used by a programming system to identify the device. The signature bytes identify the manufacturer of the device.

**Table 11** shows the logic levels for reading the signature byte, and for programming the program memory, the encryption table, and the security bits. The circuit configuration and waveforms for quick-pulse programming are shown in **figures 10 to 12**.

**Table 11**  
**OTP Programming Modes**

Mode	RESET	PSEN	ALE/ $\overline{PROG}$	EA/ $V_{PP}$	P2.7	P2.6	P3.7	P3.6
Read signature	1	0	1	1	0	0	0	0
Program code data	1	0	0	$V_{PP}$	1	0	1	1
Verify code data	1	0	1	1	0	0	1	1
Program encryption table	1	0	0	$V_{PP}$	1	0	1	0
Program security bit 1	1	0	0	$V_{PP}$	1	1	1	1
Program security bit 2	1	0	0	$V_{PP}$	1	1	0	0

### Notes :

1. "0" = valid low for that pin, "1" = valid high for that pin.
2.  $V_{PP} = 12.75 \text{ V} \pm 0.25\text{V}$
3.  $V_{CC} = 5 \text{ V} \pm 10\%$  during programming and verification.
4. ALE/ $\overline{PROG}$  receives 25 programming pulses while  $V_{PP}$  is held at 12.75 V. Each programming pulse is low for 100  $\mu\text{s}$  ( $\pm 10 \mu\text{s}$ ) and high for a minimum of 10  $\mu\text{s}$ .

1) Quick-Pulse Programming™ is a trademark phrase of Intel Corporation

### Quick-Pulse Programming

The setup for microcontroller quick-pulse programming is shown in **figure 10**. Note that the C501-1E is running with a 4 to 6 MHz oscillator. The reason the oscillator needs to be running is that the device is executing internal address and program data transfers.

The address of the OTP memory location to be programmed is applied to port 1 and 2 as shown in **figure 10**. The code byte to be programmed into that location is applied to port 0. RESET,  $\overline{\text{PSEN}}$  and pins of port 2 and 3 specified in **table 11** are held at the "Program code data" levels. The ALE/ $\overline{\text{PROG}}$  signal is pulsed low 25 times as shown in **figure 11**.

For programming of the encryption table, the 25 pulse programming sequence must be repeated for addresses 0 through 1FH, using the "Program encryption table" levels. After the encryption table is programmed, verification cycles will produce only encrypted data.

For programming of the security bits, the 25 pulse programming sequence must be repeated using the "Program security bit" levels. After one security bit is programmed, further programming of the code memory and encryption table is disabled. However, the other security bit can still be programmed.

Note that the  $\overline{\text{EA}}/V_{\text{PP}}$  pin must not be allowed to go above the maximum specified  $V_{\text{PP}}$  level, for any amount of time. Even a narrow glitch above that voltage can cause permanent damage to the device. The  $V_{\text{PP}}$  source should be well regulated and free of glitches and overshoots.

### Program Verification

If security bit 2 has not been programmed, the on-chip OTP program memory can be read out for program verification. The address of the OTP program memory locations to be read is applied to ports 1 and 2 as shown in **figure 12**. The other pins are held at the "Verify code data" levels indicated in **table 11**. The contents of the address location will be emitted on port 0. External pullups are required on port 0 for this operation.

If the encryption table has been programmed, the data presented at port 0 will be the exclusive NOR of the program byte with one of the encryption bytes. The user will have to know the encryption table contents in order to correctly decode the verification data. The encryption table itself cannot be read out.

### Reading the Signature Bytes

The signature bytes are read by the same procedure as a normal verification of locations 30H and 31H, except that P3.6 and P3.7 need to be pulled to a logic low. The values are :

30H = E0H indicates manufacturer

31H = 71H indicates C501-1E

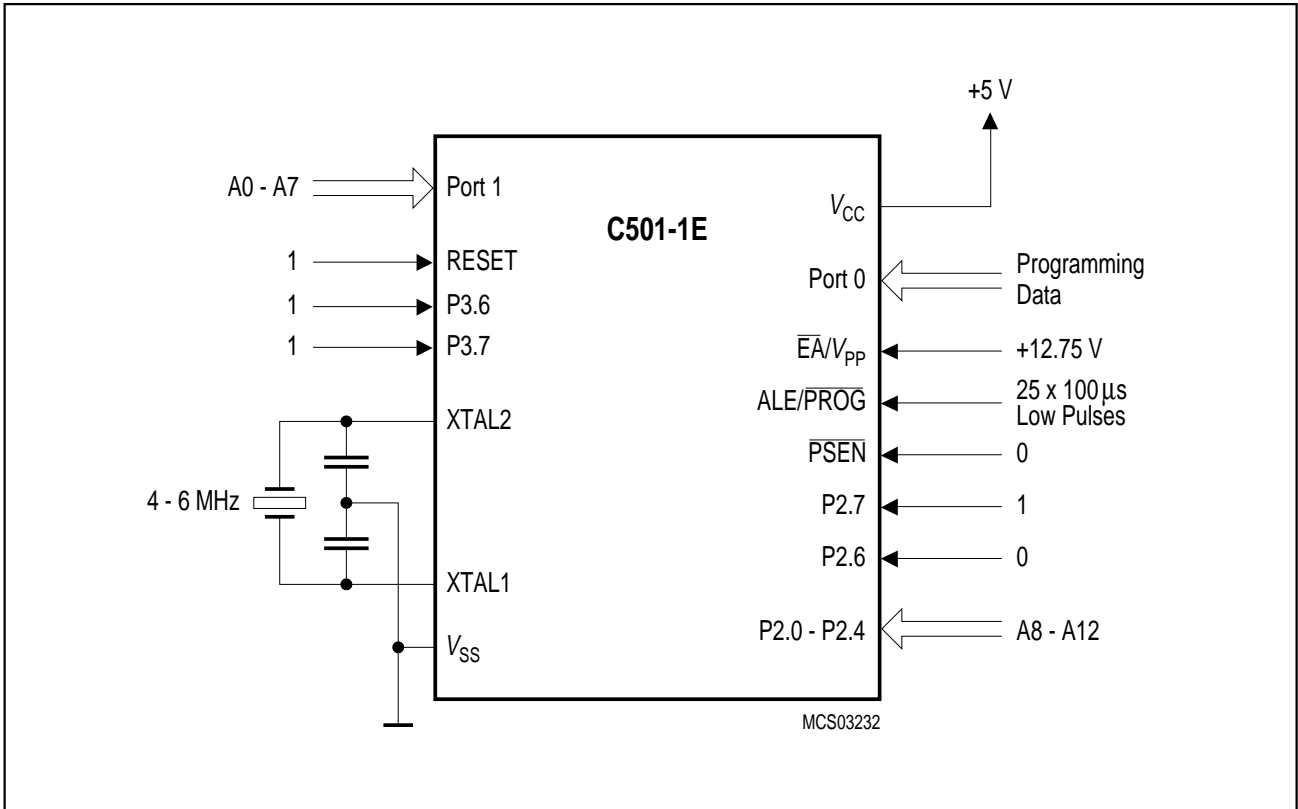

**Figure 10**  
C501-1E OTP Memory Programming Configuration

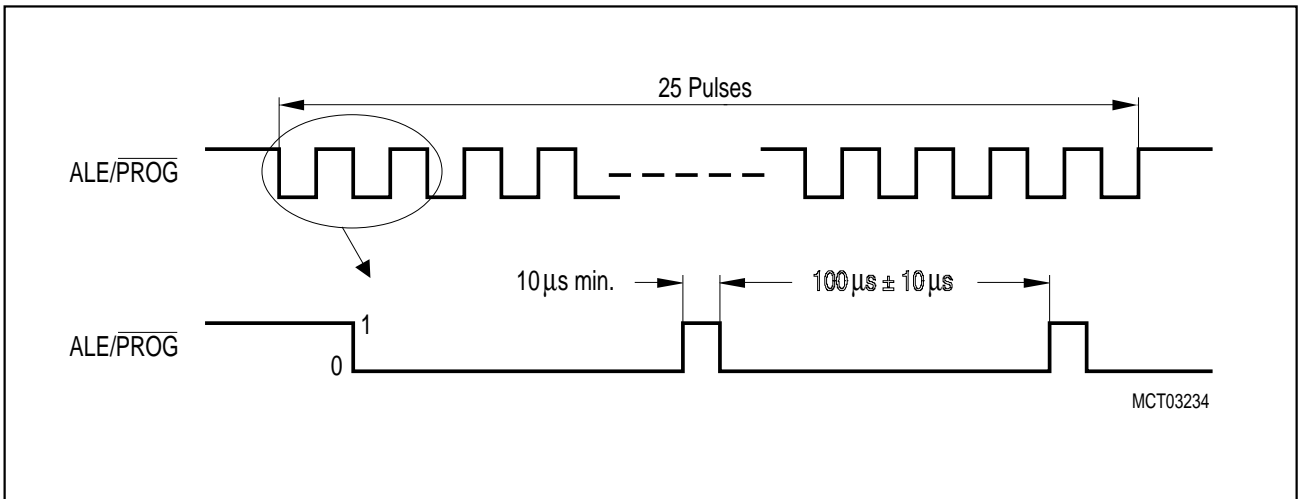

**Figure 11**  
C501-1E ALE/PROG Waveform

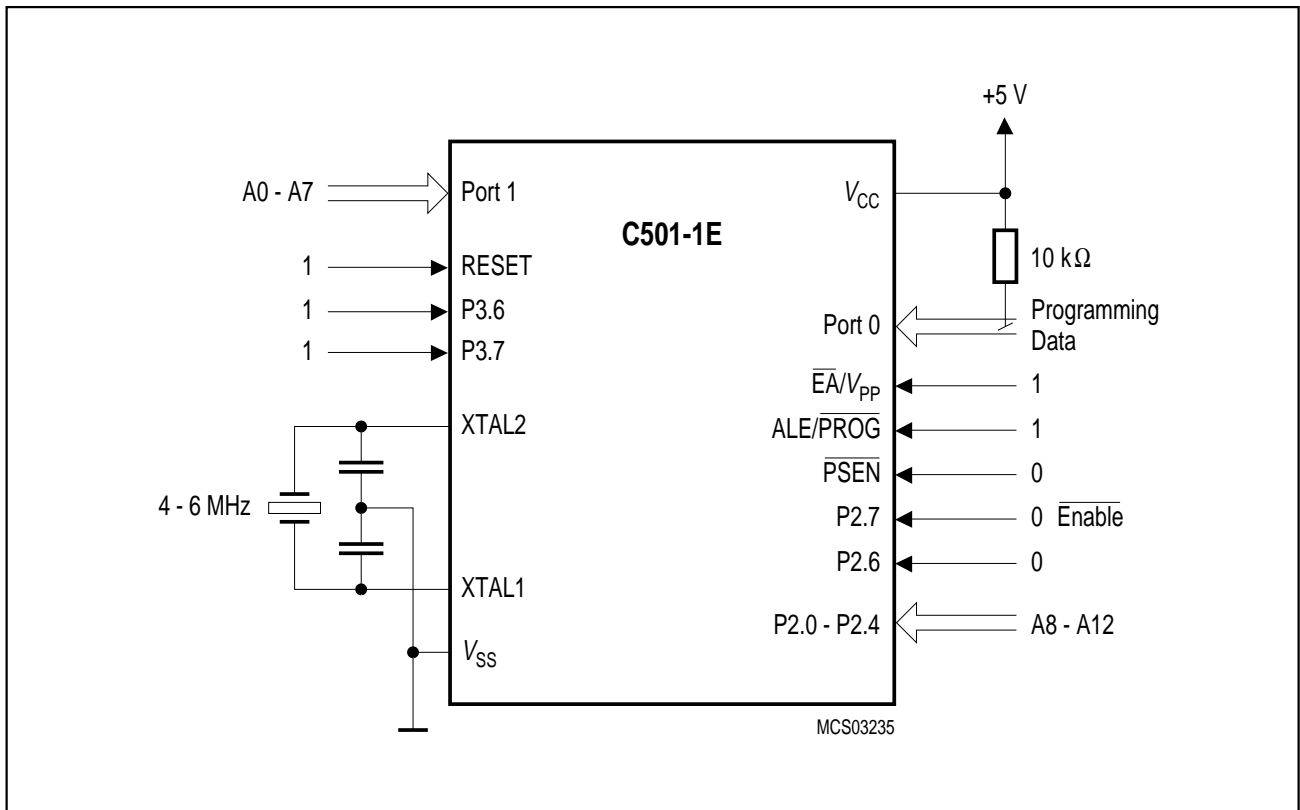

**Figure 12**  
**C501-1E OTP Memory Verification**

**Absolute Maximum Ratings**

Ambient temperature under bias ( $T_A$ ) .....	– 40 to 85 °C
Storage temperature ( $T_{stg}$ ) .....	– 65 °C to 150 °C
Voltage on $V_{CC}$ pins with respect to ground ( $V_{SS}$ ) .....	– 0.5 V to 6.5 V
Voltage on any pin with respect to ground ( $V_{SS}$ ) .....	– 0.5 V to $V_{CC} + 0.5$ V
Input current on any pin during overload condition .....	– 10 mA to 10 mA
Absolute sum of all input currents during overload condition .....	100 mA
Power dissipation .....	TBD

**Note:** Stresses above those listed under “Absolute Maximum Ratings” may cause permanent damage of the device. This is a stress rating only and functional operation of the device at these or any other conditions above those indicated in the operational sections of this specification is not implied. Exposure to absolute maximum rating conditions for longer periods may affect device reliability. During overload conditions ( $V_{IN} > V_{CC}$  or  $V_{IN} < V_{SS}$ ) the Voltage on  $V_{CC}$  pins with respect to ground ( $V_{SS}$ ) must not exceed the values defined by the absolute maximum ratings.

## DC Characteristics for C501-L / C501-1R

$V_{CC} = 5\text{ V} + 10\%, -15\%$ ;  $V_{SS} = 0\text{ V}$ ;  $T_A = 0\text{ }^\circ\text{C}$  to  $70\text{ }^\circ\text{C}$  for the SAB-C501  
 $T_A = -40\text{ }^\circ\text{C}$  to  $85\text{ }^\circ\text{C}$  for the SAF-C501

Parameter	Symbol	Limit Values		Unit	Test Condition
		min.	max.		
Input low voltage (except $\overline{EA}$ , RESET)	$V_{IL}$	-0.5	$0.2 V_{CC} - 0.1$	V	-
Input low voltage ( $\overline{EA}$ )	$V_{IL1}$	-0.5	$0.2 V_{CC} - 0.3$	V	-
Input low voltage (RESET)	$V_{IL2}$	-0.5	$0.2 V_{CC} + 0.1$	V	-
Input high voltage (except XTAL1, $\overline{EA}$ , RESET)	$V_{IH}$	$0.2 V_{CC} + 0.9$	$V_{CC} + 0.5$	V	-
Input high voltage to XTAL1	$V_{IH1}$	$0.7 V_{CC}$	$V_{CC} + 0.5$	V	-
Input high voltage to $\overline{EA}$ , RESET	$V_{IH2}$	$0.6 V_{CC}$	$V_{CC} + 0.5$	V	-
Output low voltage (ports 1, 2, 3)	$V_{OL}$	-	0.45	V	$I_{OL} = 1.6\text{ mA}^1$
Output low voltage (port 0, ALE, $\overline{PSEN}$ )	$V_{OL1}$	-	0.45	V	$I_{OL} = 3.2\text{ mA}^1$
Output high voltage (ports 1, 2, 3)	$V_{OH}$	2.4 $0.9 V_{CC}$	- -	V	$I_{OH} = -80\text{ }\mu\text{A}$ , $I_{OH} = -10\text{ }\mu\text{A}$
Output high voltage (port 0 in external bus mode, ALE, $\overline{PSEN}$ )	$V_{OH1}$	2.4 $0.9 V_{CC}$	- -	V	$I_{OH} = -800\text{ }\mu\text{A}^2$ , $I_{OH} = -80\text{ }\mu\text{A}^2$
Logic 0 input current (ports 1, 2, 3)	$I_{IL}$	-10	-50	$\mu\text{A}$	$V_{IN} = 0.45\text{ V}$
Logical 1-to-0 transition current (ports 1, 2, 3)	$I_{TL}$	-65	-650	$\mu\text{A}$	$V_{IN} = 2\text{ V}$
Input leakage current (port 0, $\overline{EA}$ )	$I_{LI}$	-	$\pm 1$	$\mu\text{A}$	$0.45 < V_{IN} < V_{CC}$
Pin capacitance	$C_{IO}$	-	10	pF	$f_C = 1\text{ MHz}$ , $T_A = 25\text{ }^\circ\text{C}$
Power supply current:					
Active mode, 12 MHz <sup>7)</sup>	$I_{CC}$	-	21	mA	$V_{CC} = 5\text{ V}$ , <sup>4)</sup>
Idle mode, 12 MHz <sup>7)</sup>	$I_{CC}$	-	4.8	mA	$V_{CC} = 5\text{ V}$ , <sup>5)</sup>
Active mode, 24 MHz <sup>7)</sup>	$I_{CC}$	-	36.2	mA	$V_{CC} = 5\text{ V}$ , <sup>4)</sup>
Idle mode, 24 MHz <sup>7)</sup>	$I_{CC}$	-	8.2	mA	$V_{CC} = 5\text{ V}$ , <sup>5)</sup>
Active mode, 40 MHz <sup>7)</sup>	$I_{CC}$	-	56.5	mA	$V_{CC} = 5\text{ V}$ , <sup>4)</sup>
Idle mode, 40 MHz <sup>7)</sup>	$I_{CC}$	-	12.7	mA	$V_{CC} = 5\text{ V}$ , <sup>5)</sup>
Power Down Mode	$I_{PD}$	-	50	$\mu\text{A}$	$V_{CC} = 2 \dots 5.5\text{ V}$ <sup>3)</sup>

Notes see page 32.

## DC Characteristics for C501-1E

$V_{CC} = 5\text{ V} + 10\%, -15\%$ ;  $V_{SS} = 0\text{ V}$ ;

$T_A = 0\text{ °C to }70\text{ °C}$  for the SAB-C501

$T_A = -40\text{ °C to }85\text{ °C}$  for the SAF-C501

Parameter	Symbol	Limit Values		Unit	Test Condition
		min.	max.		
Input low voltage (except $\overline{EA}/V_{PP}$ , RESET)	$V_{IL}$	-0.5	$0.2 V_{CC} - 0.1$	V	-
Input low voltage ( $\overline{EA}/V_{PP}$ )	$V_{IL1}$	-0.5	$0.1 V_{CC} - 0.1$	V	-
Input low voltage (RESET)	$V_{IL2}$	-0.5	$0.2 V_{CC} + 0.1$	V	-
Input high voltage (except XTAL1, $\overline{EA}/V_{PP}$ , RESET)	$V_{IH}$	$0.2 V_{CC} + 0.9$	$V_{CC} + 0.5$	V	-
Input high voltage to XTAL1	$V_{IH1}$	$0.7 V_{CC}$	$V_{CC} + 0.5$	V	-
Input high voltage to $\overline{EA}/V_{PP}$ , RESET	$V_{IH2}$	$0.6 V_{CC}$	$V_{CC} + 0.5$	V	-
Output low voltage (ports 1, 2, 3)	$V_{OL}$	-	0.45	V	$I_{OL} = 1.6\text{ mA}^1)$
Output low voltage (port 0, $\overline{ALE}/\overline{PROG}$ , $\overline{PSEN}$ )	$V_{OL1}$	-	0.45	V	$I_{OL} = 3.2\text{ mA}^1)$
Output high voltage (ports 1, 2, 3)	$V_{OH}$	2.4 $0.9 V_{CC}$	- -	V	$I_{OH} = -80\text{ }\mu\text{A}$ , $I_{OH} = -10\text{ }\mu\text{A}$
Output high voltage (port 0 in external bus mode, $\overline{ALE}/\overline{PROG}$ , $\overline{PSEN}$ )	$V_{OH1}$	2.4 $0.9 V_{CC}$	- -	V	$I_{OH} = -800\text{ }\mu\text{A}^2)$ , $I_{OH} = -80\text{ }\mu\text{A}^2)$
Logic 0 input current (ports 1, 2, 3)	$I_{IL}$	-10	-50	$\mu\text{A}$	$V_{IN} = 0.45\text{ V}$
Logical 1-to-0 transition current (ports 1, 2, 3)	$I_{TL}$	-65	-650	$\mu\text{A}$	$V_{IN} = 2\text{ V}$
Input leakage current (port 0, $\overline{EA}/V_{PP}$ )	$I_{LI}$	-	$\pm 1$	$\mu\text{A}$	$0.45 < V_{IN} < V_{CC}$
Pin capacitance	$C_{IO}$	-	10	pF	$f_C = 1\text{ MHz}$ , $T_A = 25\text{ °C}$
Power supply current:					
Active mode, 12 MHz <sup>7)</sup>	$I_{CC}$	-	21	mA	$V_{CC} = 5\text{ V}$ , <sup>4)</sup>
Idle mode, 12 MHz <sup>7)</sup>	$I_{CC}$	-	18	mA	$V_{CC} = 5\text{ V}$ , <sup>5)</sup>
Active mode, 24 MHz <sup>7)</sup>	$I_{CC}$	-	36.2	mA	$V_{CC} = 5\text{ V}$ , <sup>4)</sup>
Idle mode, 24 MHz <sup>7)</sup>	$I_{CC}$	-	20	mA	$V_{CC} = 5\text{ V}$ , <sup>5)</sup>
Power Down Mode	$I_{PD}$	-	50	$\mu\text{A}$	$V_{CC} = 2 \dots 5.5\text{ V}^3)$

Notes see next page.

**Notes:**

- 1) Capacitive loading on ports 0 and 2 may cause spurious noise pulses to be superimposed on the  $V_{OL}$  of ALE and port 3. The noise is due to external bus capacitance discharging into the port 0 and port 2 pins when these pins make 1-to-0 transitions during bus operation. In the worst case (capacitive loading > 100 pF), the noise pulse on ALE line may exceed 0.8 V. In such cases it may be desirable to qualify ALE with a schmitt-trigger, or use an address latch with a schmitt-trigger strobe input.
- 2) Capacitive loading on ports 0 and 2 may cause the  $V_{OH}$  on ALE and  $\overline{PSEN}$  to momentarily fall below the 0.9  $V_{CC}$  specification when the address lines are stabilizing.
- 3)  $I_{PD}$  (Power Down Mode) is measured under following conditions:  
 $\overline{EA} = \text{Port0} = V_{CC}$ ; RESET =  $V_{SS}$ ; XTAL2 = N.C.; XTAL1 =  $V_{SS}$ ; all other pins are disconnected.
- 4)  $I_{CC}$  (active mode) is measured with:  
 XTAL1 driven with  $t_{CLCH}$ ,  $t_{CHCL} = 5$  ns,  $V_{IL} = V_{SS} + 0.5$  V,  $V_{IH} = V_{CC} - 0.5$  V; XTAL2 = N.C.;  
 $\overline{EA} = \text{Port0} = \text{RESET} = V_{CC}$ ; all other pins are disconnected.  $I_{CC}$  would be slightly higher if a crystal oscillator is used (appr. 1 mA).
- 5)  $I_{CC}$  (Idle mode) is measured with all output pins disconnected and with all peripherals disabled;  
 XTAL1 driven with  $t_{CLCH}$ ,  $t_{CHCL} = 5$  ns,  $V_{IL} = V_{SS} + 0.5$  V,  $V_{IH} = V_{CC} - 0.5$  V; XTAL2 = N.C.;  
 RESET =  $\overline{EA} = V_{SS}$ ; Port0 =  $V_{CC}$ ; all other pins are disconnected;
- 7)  $I_{CC \text{ max}}$  at other frequencies is given by:  
 active mode:  $I_{CC} = 1.27 \times f_{OSC} + 5.73$   
 idle mode:  $I_{CC} = 0.28 \times f_{OSC} + 1.45$  (C501-L and C501-1R only)  
 where  $f_{OSC}$  is the oscillator frequency in MHz.  $I_{CC}$  values are given in mA and measured at  $V_{CC} = 5$  V.



### AC Characteristics for C501-L / C501-1R / C501-1E

$V_{CC} = 5\text{ V} + 10\%, -15\%$ ;  $V_{SS} = 0\text{ V}$      $T_A = 0\text{ }^\circ\text{C}$  to  $70\text{ }^\circ\text{C}$     for the SAB-C501  
 $T_A = -40\text{ }^\circ\text{C}$  to  $85\text{ }^\circ\text{C}$     for the SAF-C501

( $C_L$  for port 0, ALE and  $\overline{\text{PSEN}}$  outputs = 100 pF;  $C_L$  for all other outputs = 80 pF)

### Program Memory Characteristics

Parameter	Symbol	Limit Values				Unit
		12 MHz Clock		Variable Clock $1/t_{\text{CLCL}} = 3.5\text{ MHz to }12\text{ MHz}$		
		min.	max.	min.	max.	
ALE pulse width	$t_{\text{LHLL}}$	127	–	$2t_{\text{CLCL}} - 40$	–	ns
Address setup to ALE	$t_{\text{AVLL}}$	43	–	$t_{\text{CLCL}} - 40$	–	ns
Address hold after ALE	$t_{\text{LLAX}}$	30	–	$t_{\text{CLCL}} - 53$	–	ns
ALE low to valid instr in	$t_{\text{LLIV}}$	–	233	–	$4t_{\text{CLCL}} - 100$	ns
ALE to $\overline{\text{PSEN}}$	$t_{\text{LLPL}}$	58	–	$t_{\text{CLCL}} - 25$	–	ns
$\overline{\text{PSEN}}$ pulse width	$t_{\text{PLPH}}$	215	–	$3t_{\text{CLCL}} - 35$	–	ns
$\overline{\text{PSEN}}$ to valid instr in	$t_{\text{PLIV}}$	–	150	–	$3t_{\text{CLCL}} - 100$	ns
Input instruction hold after $\overline{\text{PSEN}}$	$t_{\text{PXIX}}$	0	–	0	–	ns
Input instruction float after $\overline{\text{PSEN}}$	$t_{\text{PXIZ}}^*)$	–	63	–	$t_{\text{CLCL}} - 20$	ns
Address valid after $\overline{\text{PSEN}}$	$t_{\text{PXAV}}^*)$	75	–	$t_{\text{CLCL}} - 8$	–	ns
Address to valid instr in	$t_{\text{AVIV}}$	–	302	–	$5t_{\text{CLCL}} - 115$	ns
Address float to $\overline{\text{PSEN}}$	$t_{\text{AZPL}}$	0	–	0	–	ns

\*) Interfacing the C501 to devices with float times up to 75 ns is permissible. This limited bus contention will not cause any damage to port 0 Drivers.

AC Characteristics for C501-L / C501-1R / C501-1E (cont'd)

External Data Memory Characteristics

Parameter	Symbol	Limit Values				Unit
		12 MHz Clock		Variable Clock $1/t_{CLCL} = 3.5 \text{ MHz to } 12 \text{ MHz}$		
		min.	max.	min.	max.	
$\overline{RD}$ pulse width	$t_{RLRH}$	400	–	$6t_{CLCL} - 100$	–	ns
$\overline{WR}$ pulse width	$t_{WLWH}$	400	–	$6t_{CLCL} - 100$	–	ns
Address hold after ALE	$t_{LLAX2}$	30	–	$t_{CLCL} - 53$	–	ns
$\overline{RD}$ to valid data in	$t_{RLDV}$	–	252	–	$5t_{CLCL} - 165$	ns
Data hold after $\overline{RD}$	$t_{RHDX}$	0	–	0	–	ns
Data float after $\overline{RD}$	$t_{RHDZ}$	–	97	–	$2t_{CLCL} - 70$	ns
ALE to valid data in	$t_{LLDV}$	–	517	–	$8t_{CLCL} - 150$	ns
Address to valid data in	$t_{AVDV}$	–	585	–	$9t_{CLCL} - 165$	ns
ALE to $\overline{WR}$ or $\overline{RD}$	$t_{LLWL}$	200	300	$3t_{CLCL} - 50$	$3t_{CLCL} + 50$	ns
Address valid to $\overline{WR}$ or $\overline{RD}$	$t_{AVWL}$	203	–	$4t_{CLCL} - 130$	–	ns
$\overline{WR}$ or $\overline{RD}$ high to ALE high	$t_{WHLH}$	43	123	$t_{CLCL} - 40$	$t_{CLCL} + 40$	ns
Data valid to $\overline{WR}$ transition	$t_{QVWX}$	33	–	$t_{CLCL} - 50$	–	ns
Data setup before $\overline{WR}$	$t_{QVWH}$	433	–	$7t_{CLCL} - 150$	–	ns
Data hold after $\overline{WR}$	$t_{WHQX}$	33	–	$t_{CLCL} - 50$	–	ns
Address float after $\overline{RD}$	$t_{RLAZ}$	–	0	–	0	ns

External Clock Drive Characteristics

Parameter	Symbol	Limit Values		Unit
		Variable Clock Freq. = 3.5 MHz to 12 MHz		
		min.	max.	
Oscillator period	$t_{CLCL}$	83.3	285.7	ns
High time	$t_{CHCX}$	20	$t_{CLCL} - t_{CLCX}$	ns
Low time	$t_{CLCX}$	20	$t_{CLCL} - t_{CHCX}$	ns
Rise time	$t_{CLCH}$	–	20	ns
Fall time	$t_{CHCL}$	–	20	ns

### AC Characteristics for C501-L24 / C501-1R24 / C501-1E24

$V_{CC} = 5\text{ V} + 10\%, -15\%$ ;  $V_{SS} = 0\text{ V}$      $T_A = 0\text{ }^\circ\text{C}$  to  $70\text{ }^\circ\text{C}$     for the SAB-C501  
 $T_A = -40\text{ }^\circ\text{C}$  to  $85\text{ }^\circ\text{C}$     for the SAF-C501

( $C_L$  for port 0, ALE and  $\overline{\text{PSEN}}$  outputs = 100 pF;  $C_L$  for all other outputs = 80 pF)

### Program Memory Characteristics

Parameter	Symbol	Limit Values				Unit
		24 MHz Clock		Variable Clock $1/t_{\text{CLCL}} = 3.5\text{ MHz to }24\text{ MHz}$		
		min.	max.	min.	max.	
ALE pulse width	$t_{\text{LHLL}}$	43	–	$2t_{\text{CLCL}} - 40$	–	ns
Address setup to ALE	$t_{\text{AVLL}}$	17	–	$t_{\text{CLCL}} - 25$	–	ns
Address hold after ALE	$t_{\text{LLAX}}$	17	–	$t_{\text{CLCL}} - 25$	–	ns
ALE low to valid instr in	$t_{\text{LLIV}}$	–	80	–	$4t_{\text{CLCL}} - 87$	ns
ALE to $\overline{\text{PSEN}}$	$t_{\text{LLPL}}$	22	–	$t_{\text{CLCL}} - 20$	–	ns
$\overline{\text{PSEN}}$ pulse width	$t_{\text{PLPH}}$	95	–	$3t_{\text{CLCL}} - 30$	–	ns
$\overline{\text{PSEN}}$ to valid instr in	$t_{\text{PLIV}}$	–	60	–	$3t_{\text{CLCL}} - 65$	ns
Input instruction hold after $\overline{\text{PSEN}}$	$t_{\text{PXIX}}$	0	–	0	–	ns
Input instruction float after $\overline{\text{PSEN}}$	$t_{\text{PXIZ}}^*)$	–	32	–	$t_{\text{CLCL}} - 10$	ns
Address valid after $\overline{\text{PSEN}}$	$t_{\text{PXAV}}^*)$	37	–	$t_{\text{CLCL}} - 5$	–	ns
Address to valid instr in	$t_{\text{AVIV}}$	–	148	–	$5t_{\text{CLCL}} - 60$	ns
Address float to $\overline{\text{PSEN}}$	$t_{\text{AZPL}}$	0	–	0	–	ns

\*) Interfacing the C501 to devices with float times up to 37 ns is permissible. This limited bus contention will not cause any damage to port 0 Drivers.

AC Characteristics for C501-L24 / C501-1R24 / C501-1E24 (cont'd)

External Data Memory Characteristics

Parameter	Symbol	Limit Values				Unit
		24 MHz Clock		Variable Clock $1/t_{CLCL} = 3.5 \text{ MHz to } 24 \text{ MHz}$		
		min.	max.	min.	max.	
$\overline{RD}$ pulse width	$t_{RLRH}$	180	–	$6t_{CLCL} - 70$	–	ns
$\overline{WR}$ pulse width	$t_{WLWH}$	180	–	$6t_{CLCL} - 70$	–	ns
Address hold after ALE	$t_{LLAX2}$	15	–	$t_{CLCL} - 27$	–	ns
$\overline{RD}$ to valid data in	$t_{RLDV}$	–	118	–	$5t_{CLCL} - 90$	ns
Data hold after $\overline{RD}$	$t_{RHDX}$	0	–	0	–	ns
Data float after $\overline{RD}$	$t_{RHDZ}$	–	63	–	$2t_{CLCL} - 20$	ns
ALE to valid data in	$t_{LLDV}$	–	200	–	$8t_{CLCL} - 133$	ns
Address to valid data in	$t_{AVDV}$	–	220	–	$9t_{CLCL} - 155$	ns
ALE to $\overline{WR}$ or $\overline{RD}$	$t_{LLWL}$	75	175	$3t_{CLCL} - 50$	$3t_{CLCL} + 50$	ns
Address valid to $\overline{WR}$ or $\overline{RD}$	$t_{AVWL}$	67	–	$4t_{CLCL} - 97$	–	ns
$\overline{WR}$ or $\overline{RD}$ high to ALE high	$t_{WHLH}$	17	67	$t_{CLCL} - 25$	$t_{CLCL} + 25$	ns
Data valid to $\overline{WR}$ transition	$t_{QVWX}$	5	–	$t_{CLCL} - 37$	–	ns
Data setup before $\overline{WR}$	$t_{QVWH}$	170	–	$7t_{CLCL} - 122$	–	ns
Data hold after $\overline{WR}$	$t_{WHQX}$	15	–	$t_{CLCL} - 27$	–	ns
Address float after $\overline{RD}$	$t_{RLAZ}$	–	0	–	0	ns

External Clock Drive Characteristics

Parameter	Symbol	Limit Values		Unit
		Variable Clock Freq. = 3.5 MHz to 24 MHz		
		min.	max.	
Oscillator period	$t_{CLCL}$	41.7	285.7	ns
High time	$t_{CHCX}$	12	$t_{CLCL} - t_{CLCX}$	ns
Low time	$t_{CLCX}$	12	$t_{CLCL} - t_{CHCX}$	ns
Rise time	$t_{CLCH}$	–	12	ns
Fall time	$t_{CHCL}$	–	12	ns

## AC Characteristics for C501-L40 / C501-1R40

$V_{CC} = 5\text{ V} + 10\%, -15\%$ ;  $V_{SS} = 0\text{ V}$      $T_A = 0\text{ °C to }70\text{ °C}$     for the SAB-C501  
 $T_A = -40\text{ °C to }85\text{ °C}$     for the SAF-C501

( $C_L$  for port 0, ALE and  $\overline{\text{PSEN}}$  outputs = 100 pF;  $C_L$  for all other outputs = 80 pF)

## Program Memory Characteristics

Parameter	Symbol	Limit Values				Unit
		40 MHz Clock		Variable Clock $1/t_{\text{CLCL}} = 3.5\text{ MHz to }40\text{ MHz}$		
		min.	max.	min.	max.	
ALE pulse width	$t_{\text{LHLL}}$	35	–	$2 t_{\text{CLCL}} - 15$	–	ns
Address setup to ALE	$t_{\text{AVLL}}$	10	–	$t_{\text{CLCL}} - 15$	–	ns
Address hold after ALE	$t_{\text{LLAX}}$	10	–	$t_{\text{CLCL}} - 15$	–	ns
ALE low to valid instr in	$t_{\text{LLIV}}$	–	55	–	$4 t_{\text{CLCL}} - 45$	ns
ALE to $\overline{\text{PSEN}}$	$t_{\text{LLPL}}$	10	–	$t_{\text{CLCL}} - 15$	–	ns
$\overline{\text{PSEN}}$ pulse width	$t_{\text{PLPH}}$	60	–	$3 t_{\text{CLCL}} - 15$	–	ns
$\overline{\text{PSEN}}$ to valid instr in	$t_{\text{PLIV}}$	–	25	–	$3 t_{\text{CLCL}} - 50$	ns
Input instruction hold after $\overline{\text{PSEN}}$	$t_{\text{PXIX}}$	0	–	0	–	ns
Input instruction float after $\overline{\text{PSEN}}$	$t_{\text{PXIZ}}^*)$	–	20	–	$t_{\text{CLCL}} - 5$	ns
Address valid after $\overline{\text{PSEN}}$	$t_{\text{PXAV}}^*)$	20	–	$t_{\text{CLCL}} - 5$	–	ns
Address to valid instr in	$t_{\text{AVIV}}$	–	65	–	$5 t_{\text{CLCL}} - 60$	ns
Address float to $\overline{\text{PSEN}}$	$t_{\text{AZPL}}$	– 5	–	– 5	–	ns

\*) Interfacing the C501 to devices with float times up to 25ns is permissible. This limited bus contention will not cause any damage to port 0 Drivers.

## AC Characteristics for C501-L40 / C501-1R40 (cont'd)

### External Data Memory Characteristics

Parameter	Symbol	Limit Values				Unit
		40 MHz Clock		Variable Clock $1/t_{CLCL} = 3.5 \text{ MHz to } 40 \text{ MHz}$		
		min.	max.	min.	max.	
$\overline{RD}$ pulse width	$t_{RLRH}$	120	–	$6 t_{CLCL} - 30$	–	ns
$\overline{WR}$ pulse width	$t_{WLWH}$	120	–	$6 t_{CLCL} - 30$	–	ns
Address hold after ALE	$t_{LLAX2}$	10	–	$t_{CLCL} - 15$	–	ns
$\overline{RD}$ to valid data in	$t_{RLDV}$	–	75	–	$5 t_{CLCL} - 50$	ns
Data hold after $\overline{RD}$	$t_{RHDX}$	0	–	0	–	ns
Data float after $\overline{RD}$	$t_{RHDZ}$	–	38	–	$2 t_{CLCL} - 12$	ns
ALE to valid data in	$t_{LLDV}$	–	150	–	$8 t_{CLCL} - 50$	ns
Address to valid data in	$t_{AVDV}$	–	150	–	$9 t_{CLCL} - 75$	ns
ALE to $\overline{WR}$ or $\overline{RD}$	$t_{LLWL}$	60	90	$3 t_{CLCL} - 15$	$3 t_{CLCL} + 15$	ns
Address valid to $\overline{WR}$ or $\overline{RD}$	$t_{AVWL}$	70	–	$4 t_{CLCL} - 30$	–	ns
$\overline{WR}$ or $\overline{RD}$ high to ALE high	$t_{WHLH}$	10	40	$t_{CLCL} - 15$	$t_{CLCL} + 15$	ns
Data valid to $\overline{WR}$ transition	$t_{QVWX}$	5	–	$t_{CLCL} - 20$	–	ns
Data setup before $\overline{WR}$	$t_{QVWH}$	125	–	$7 t_{CLCL} - 50$	–	ns
Data hold after $\overline{WR}$	$t_{WHQX}$	5	–	$t_{CLCL} - 20$	–	ns
Address float after $\overline{RD}$	$t_{RLAZ}$	–	0	–	0	ns

### External Clock Drive Characteristics

Parameter	Symbol	Limit Values		Unit
		Variable Clock Freq. = 3.5 MHz to 40 MHz		
		min.	max.	
Oscillator period	$t_{CLCL}$	25	285.7	ns
High time	$t_{CHCX}$	10	$t_{CLCL} - t_{CLCX}$	ns
Low time	$t_{CLCX}$	10	$t_{CLCL} - t_{CHCX}$	ns
Rise time	$t_{CLCH}$	–	10	ns
Fall time	$t_{CHCL}$	–	10	ns

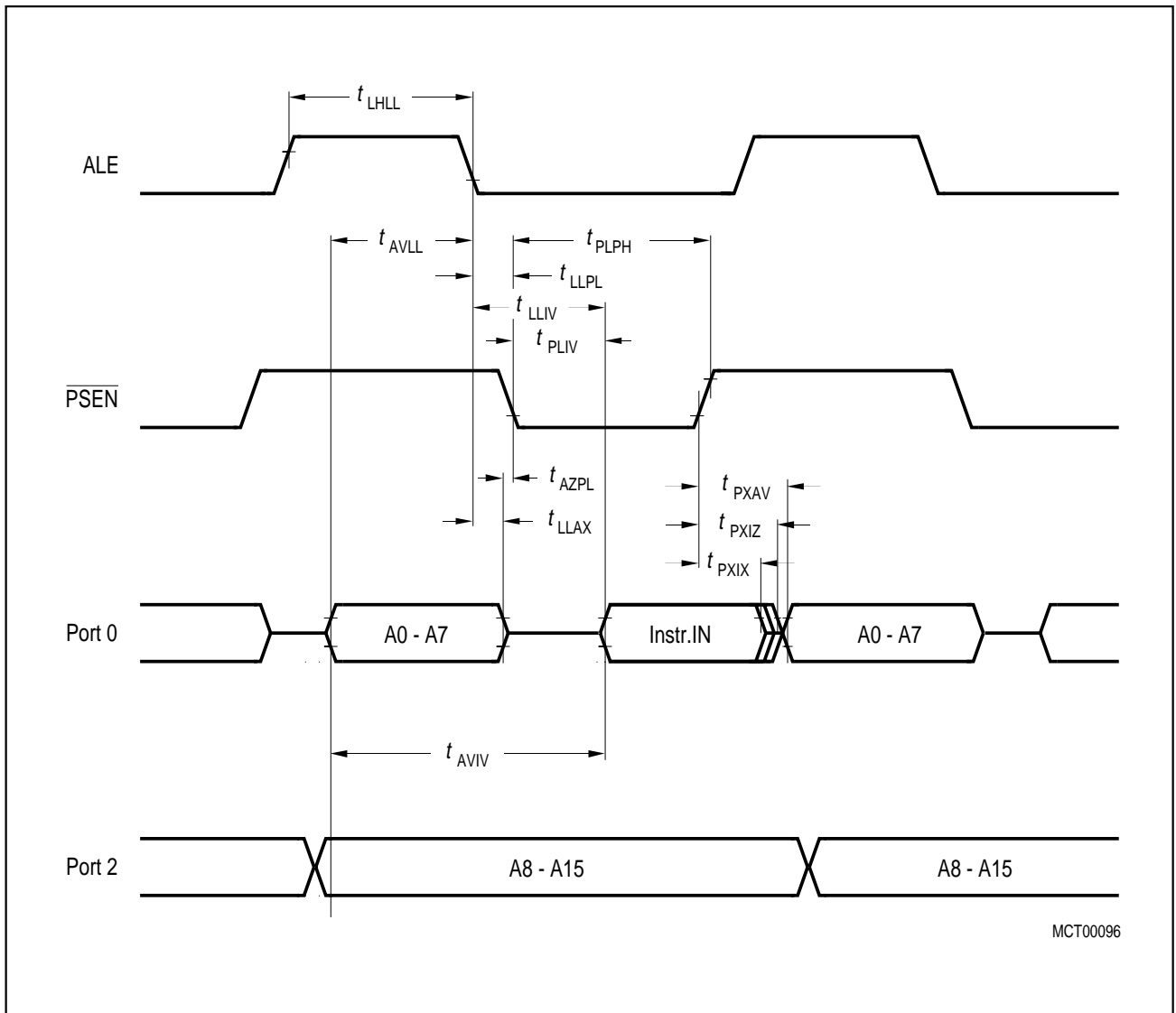

MCT00096

**Figure 13**  
**Program Memory Read Cycle**

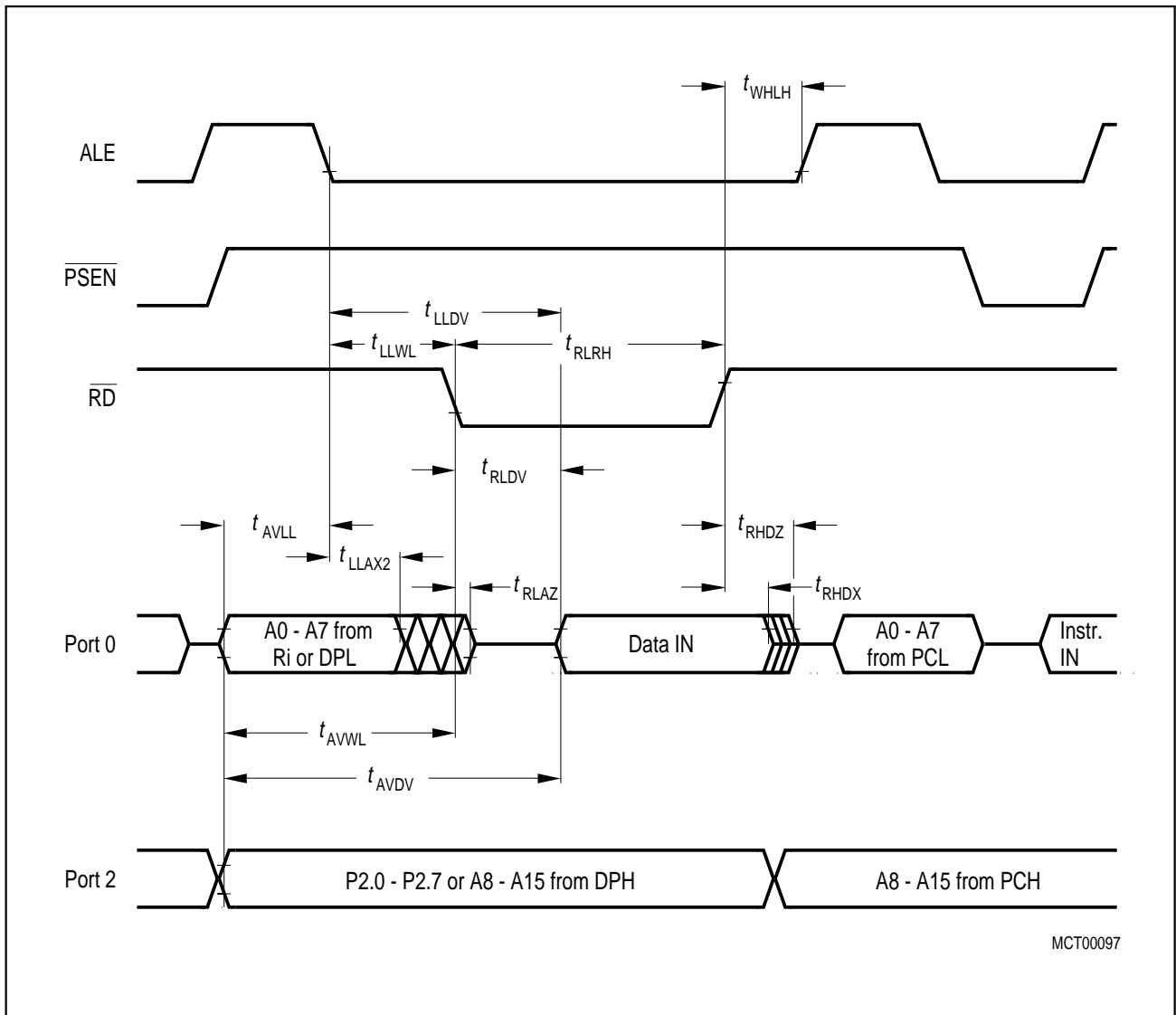

**Figure 14**  
Data Memory Read Cycle



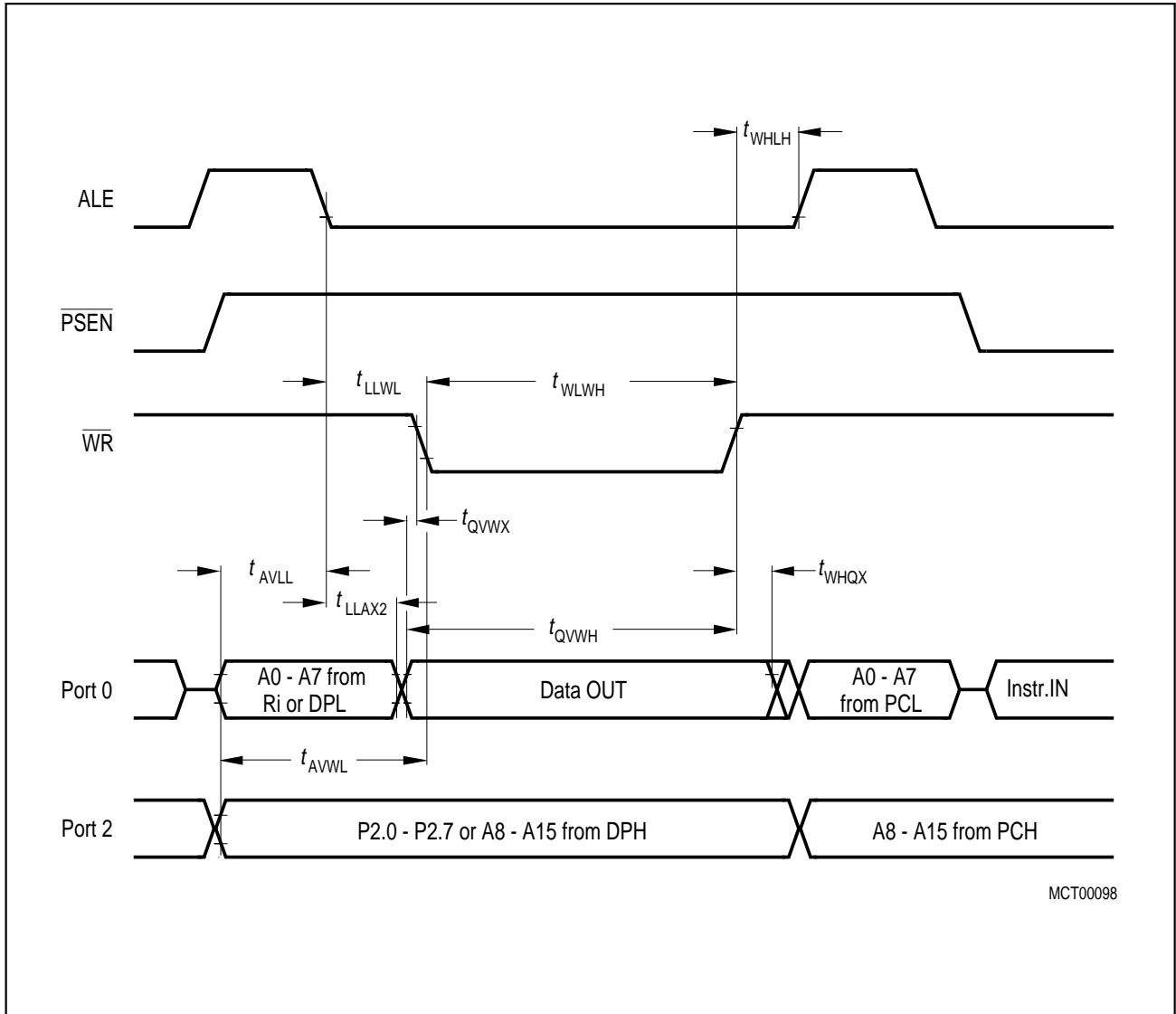

MCT00098

**Figure 15**  
Data Memory Write Cycle

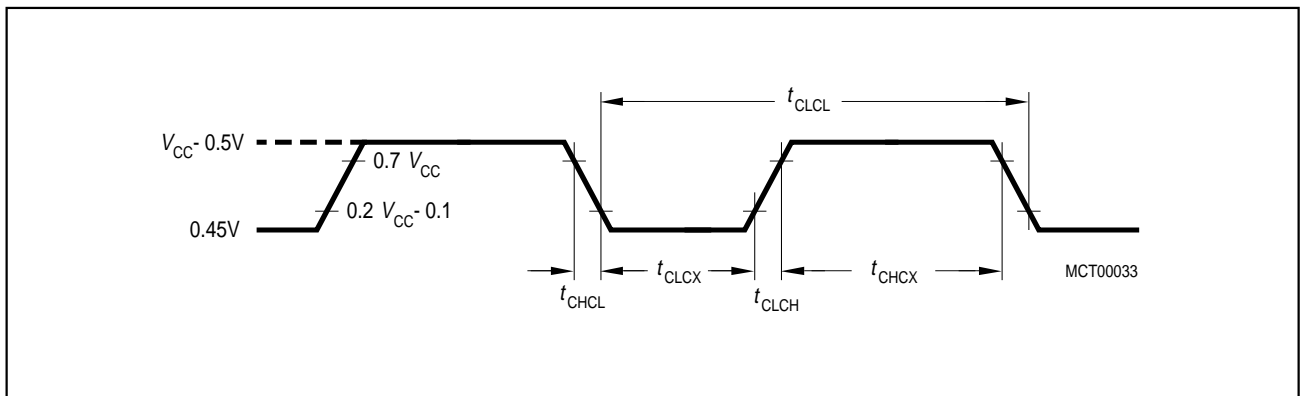

MCT00033

**Figure 16**  
External Clock Drive at XTAL2

## ROM Verification Characteristics for C501-1R

### ROM Verification Mode 1

Parameter	Symbol	Limit Values		Unit
		min.	max.	
Address to valid data	$t_{AVQV}$	—	$48t_{CLCL}$	ns
ENABLE to valid data	$t_{ELQV}$	—	$48t_{CLCL}$	ns
Data float after ENABLE	$t_{EHQZ}$	0	$48t_{CLCL}$	ns
Oscillator frequency	$1/t_{CLCL}$	4	6	MHz

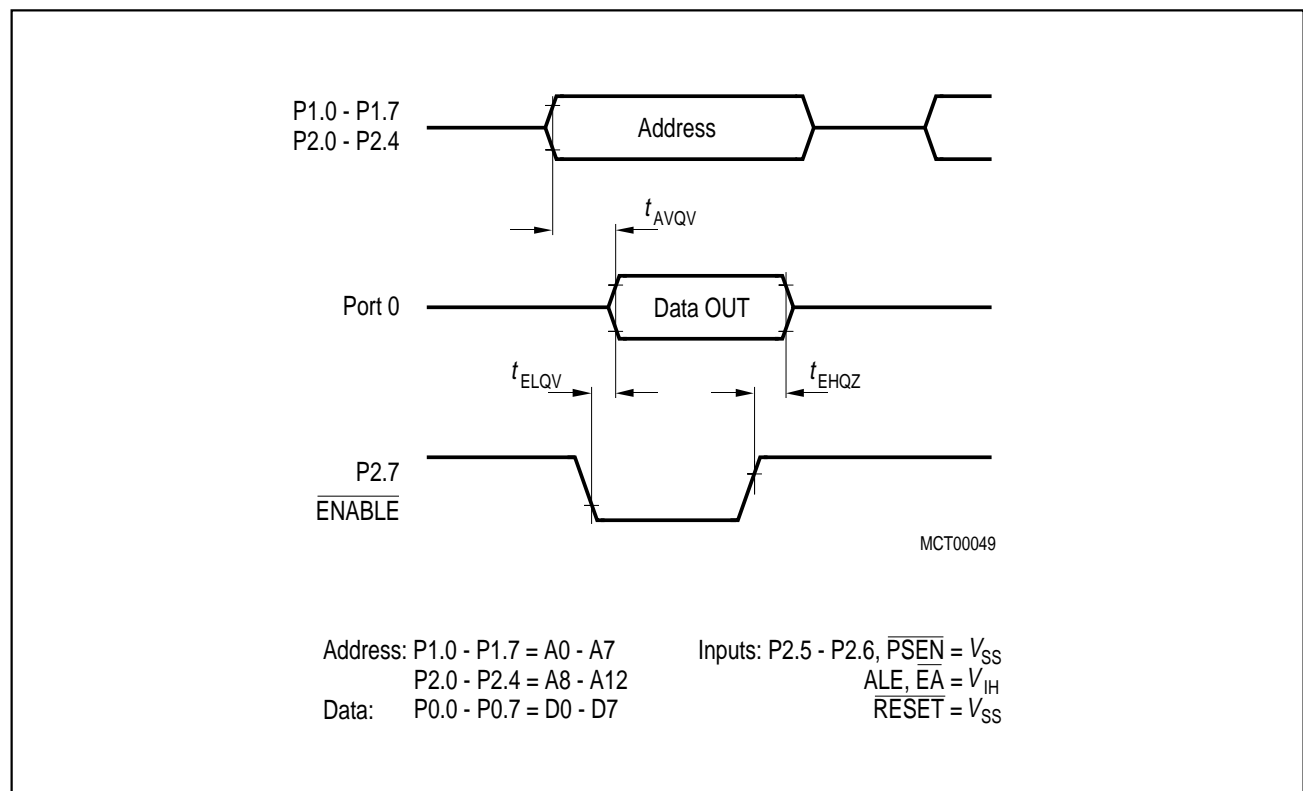
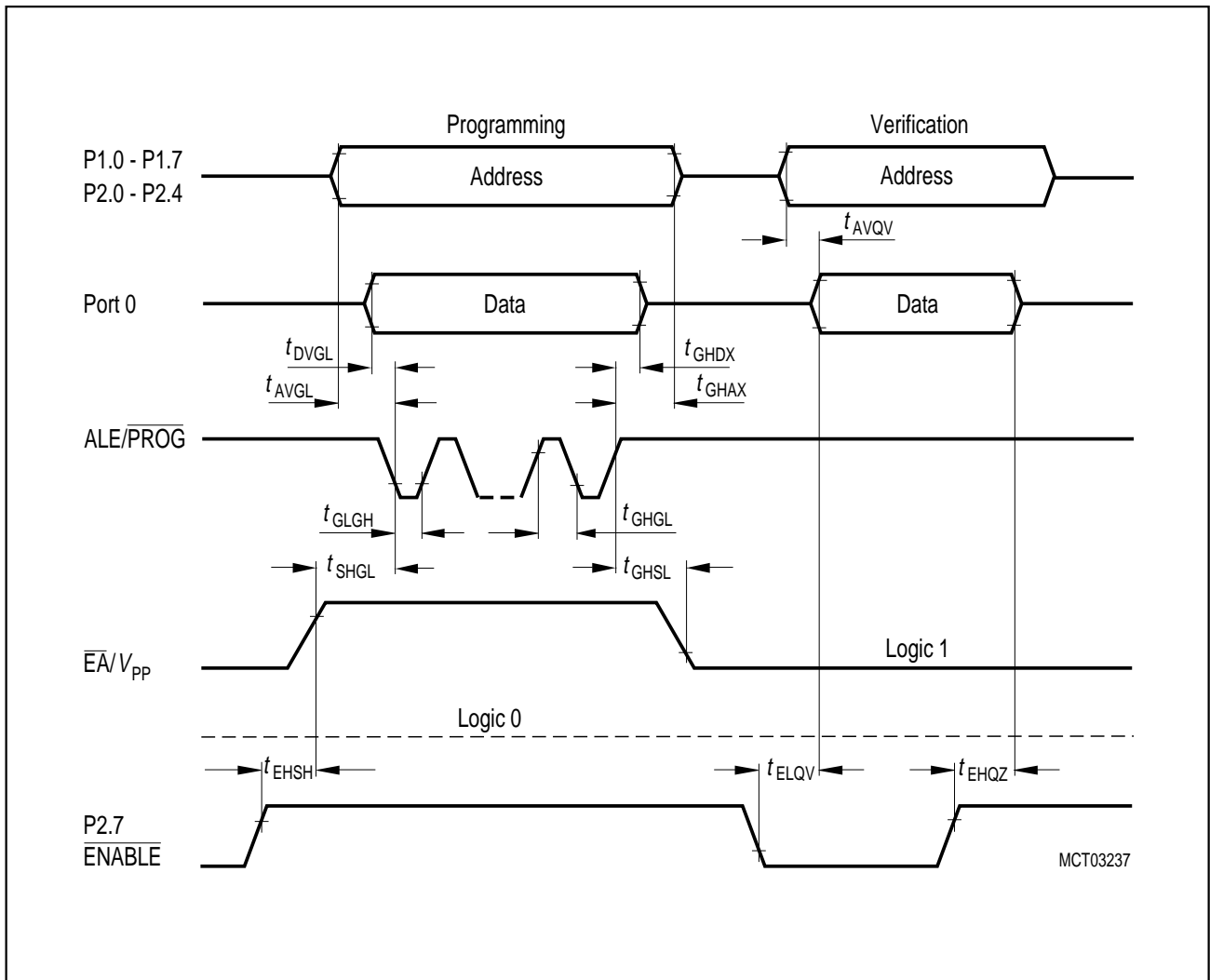

**Figure 17**  
**ROM Verification Mode 1**

## OTP Programming and Verification Characteristics

$V_{CC} = 5\text{ V} \pm 10\%$ ,  $V_{SS} = 0\text{ V}$ ,  $T_A = 21\text{ }^\circ\text{C}$  to  $+27\text{ }^\circ\text{C}$

Parameter	Symbol	Limit Values		Unit
		min.	max.	
Programming supply voltage	$V_{PP}$	12.5	13.0	V
Programming supply current	$I_{PP}$	–	50	mA
Oscillator frequency	$1 / t_{CLCL}$	4	6	MHz
Address setup to ALE/ $\overline{\text{PROG}}$ low	$t_{AVGL}$	$48 t_{CLCL}$	–	ns
Address hold after ALE/ $\overline{\text{PROG}}$	$t_{GHAX}$	$48 t_{CLCL}$	–	ns
Data setup to ALE/ $\overline{\text{PROG}}$ low	$t_{DVGL}$	$48 t_{CLCL}$	–	ns
Data hold after ALE/ $\overline{\text{PROG}}$	$t_{GHDX}$	$48 t_{CLCL}$	–	ns
P2.7 ( $\overline{\text{ENABLE}}$ ) high to $V_{PP}$	$t_{EHSB}$	$48 t_{CLCL}$	–	ns
$V_{PP}$ setup to ALE/ $\overline{\text{PROG}}$ low	$t_{SHGL}$	10	–	$\mu\text{s}$
$V_{PP}$ hold after ALE/ $\overline{\text{PROG}}$ low	$t_{GHSL}$	10	–	$\mu\text{s}$
ALE/ $\overline{\text{PROG}}$ width	$t_{GLGH}$	90	110	$\mu\text{s}$
Address to data valid	$t_{AVQV}$	–	$48 t_{CLCL}$	ns
$\overline{\text{ENABLE}}$ low to data valid	$t_{ELQV}$	–	$48 t_{CLCL}$	ns
Data float after $\overline{\text{ENABLE}}$	$t_{EHQZ}$	0	$48 t_{CLCL}$	ns
ALE/ $\overline{\text{PROG}}$ high to ALE/ $\overline{\text{PROG}}$ low	$t_{GHGL}$	10	–	$\mu\text{s}$



**Figure 18**  
**C501-1E OTP Memory Program/Read Cycle**

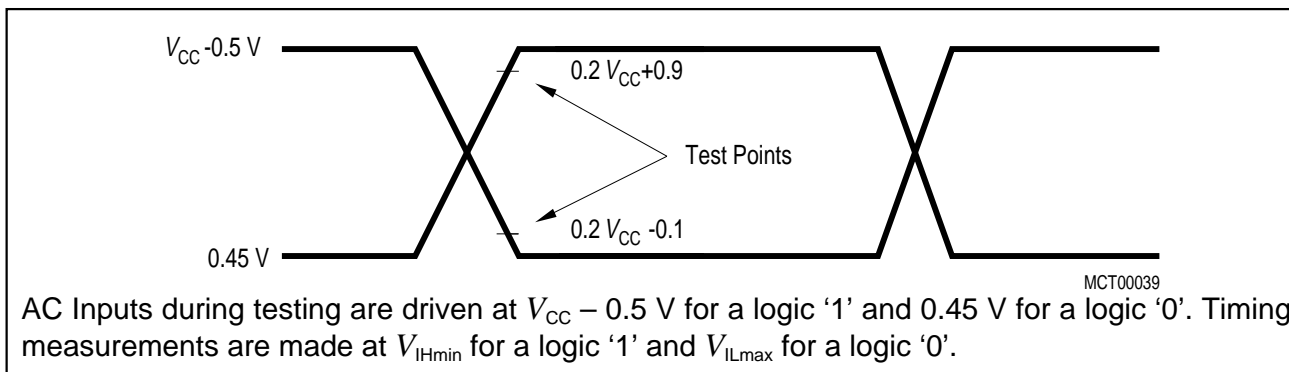

**Figure 19**  
AC Testing: Input, Output Waveforms

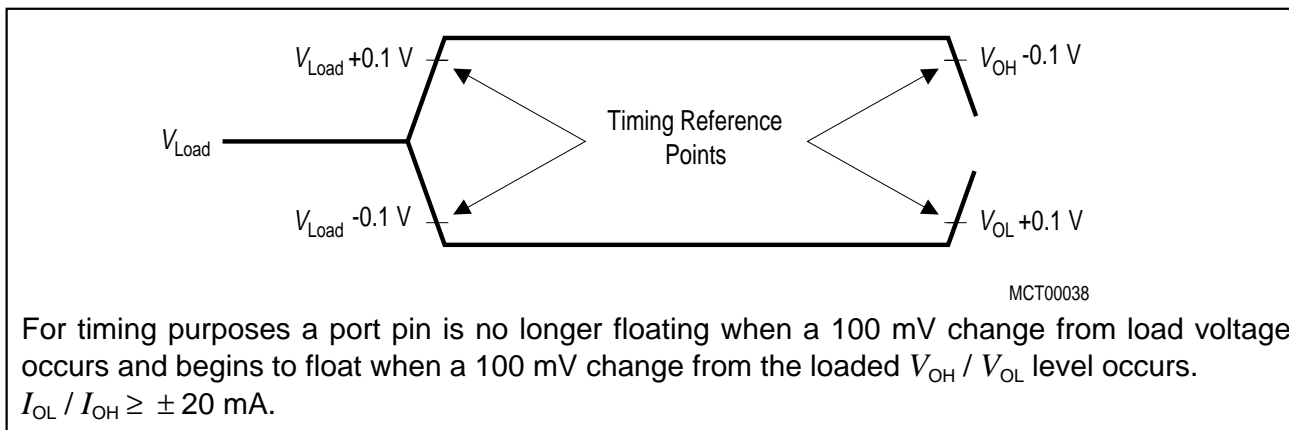

**Figure 20**  
AC Testing: Float Waveforms

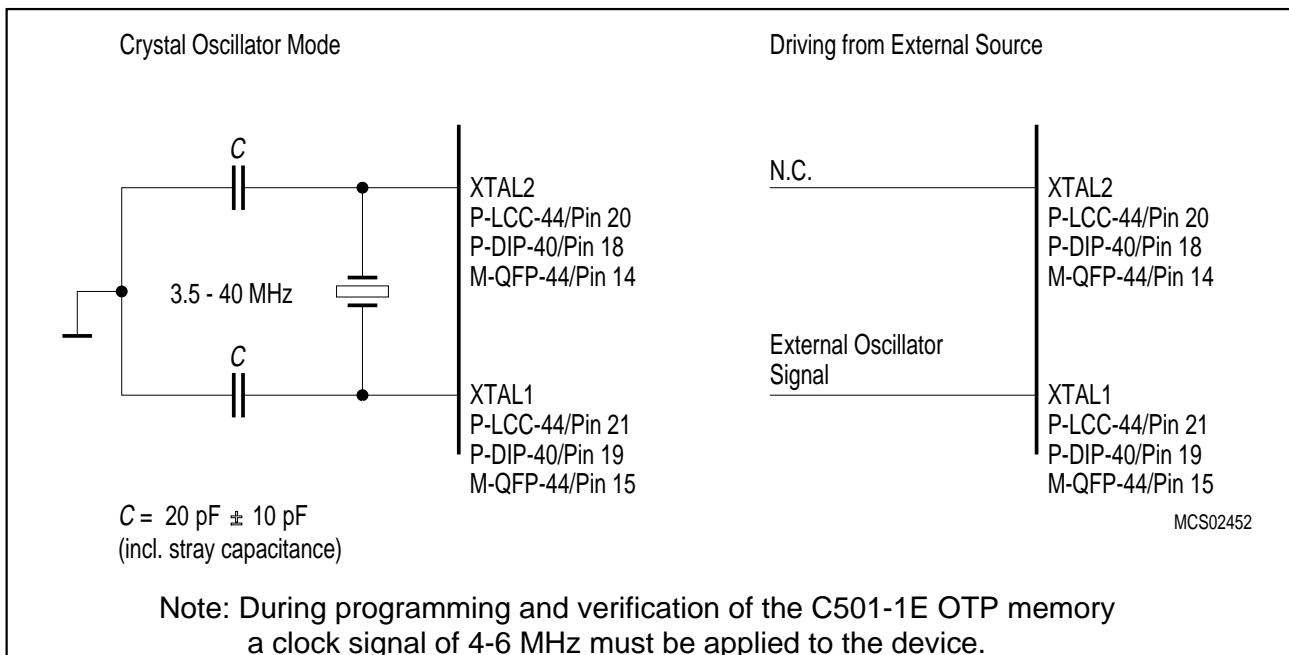

**Figure 21**  
Recommended Oscillator Circuits

Package Outlines

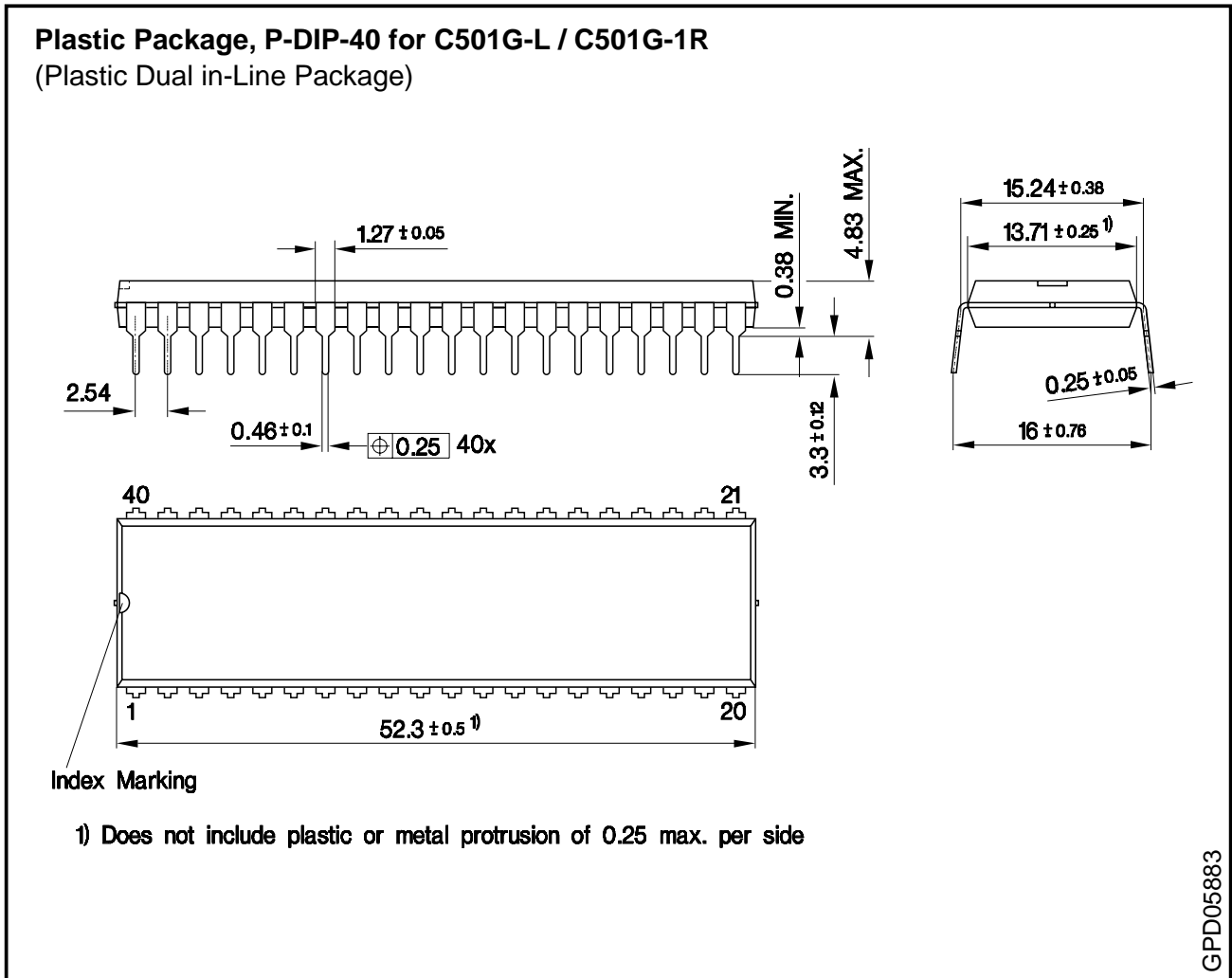

Figure 22  
 P-DIP-40 Package Outlines

Sorts of Packing

Package outlines for tubes, trays etc. are contained in our Data Book "Package Information"

Dimensions in mm

Plastic Package, P-LCC-44 – SMD for C501G-L / C501G-1R / C501G-1E  
(Plastic Leaded Chip-Carrier)

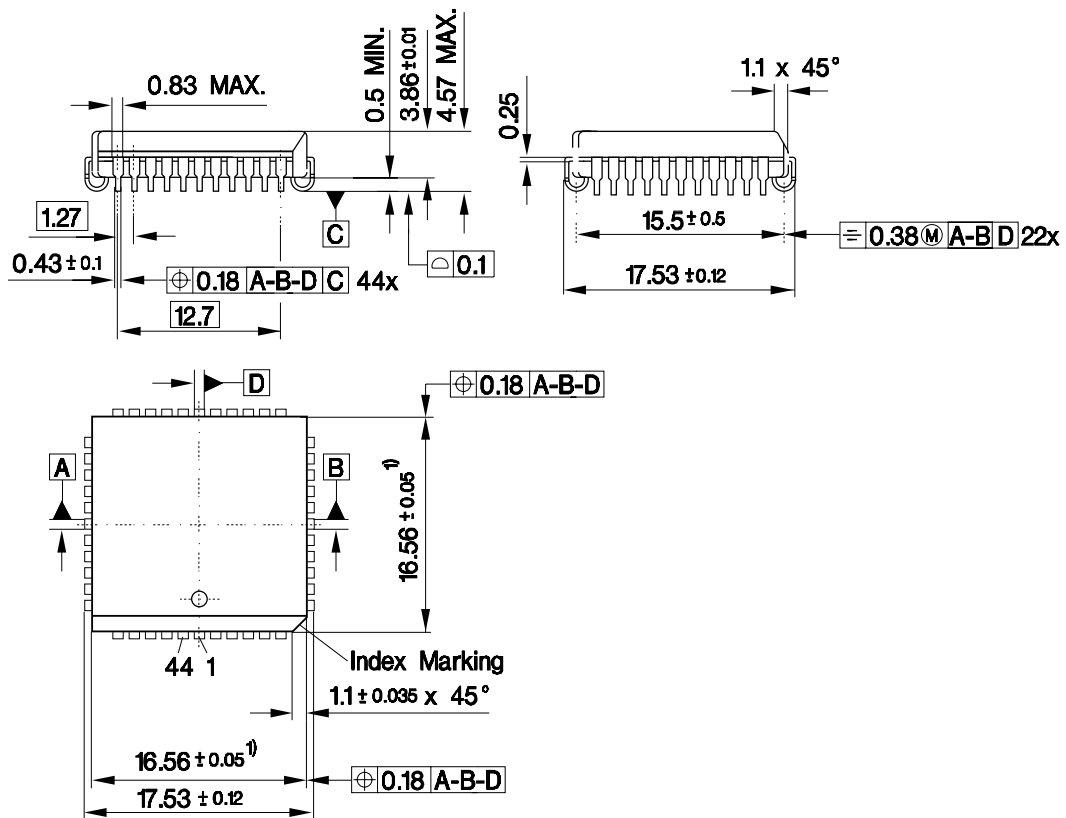

1) Does not include plastic or metal protrusion of 0.15 max. per side

GPL05882

Figure 23  
P-LCC-44 Package Outlines

Sorts of Packing

Package outlines for tubes, trays etc. are contained in our Data Book "Package Information"

SMD = Surface Mounted Device

Dimensions in mm

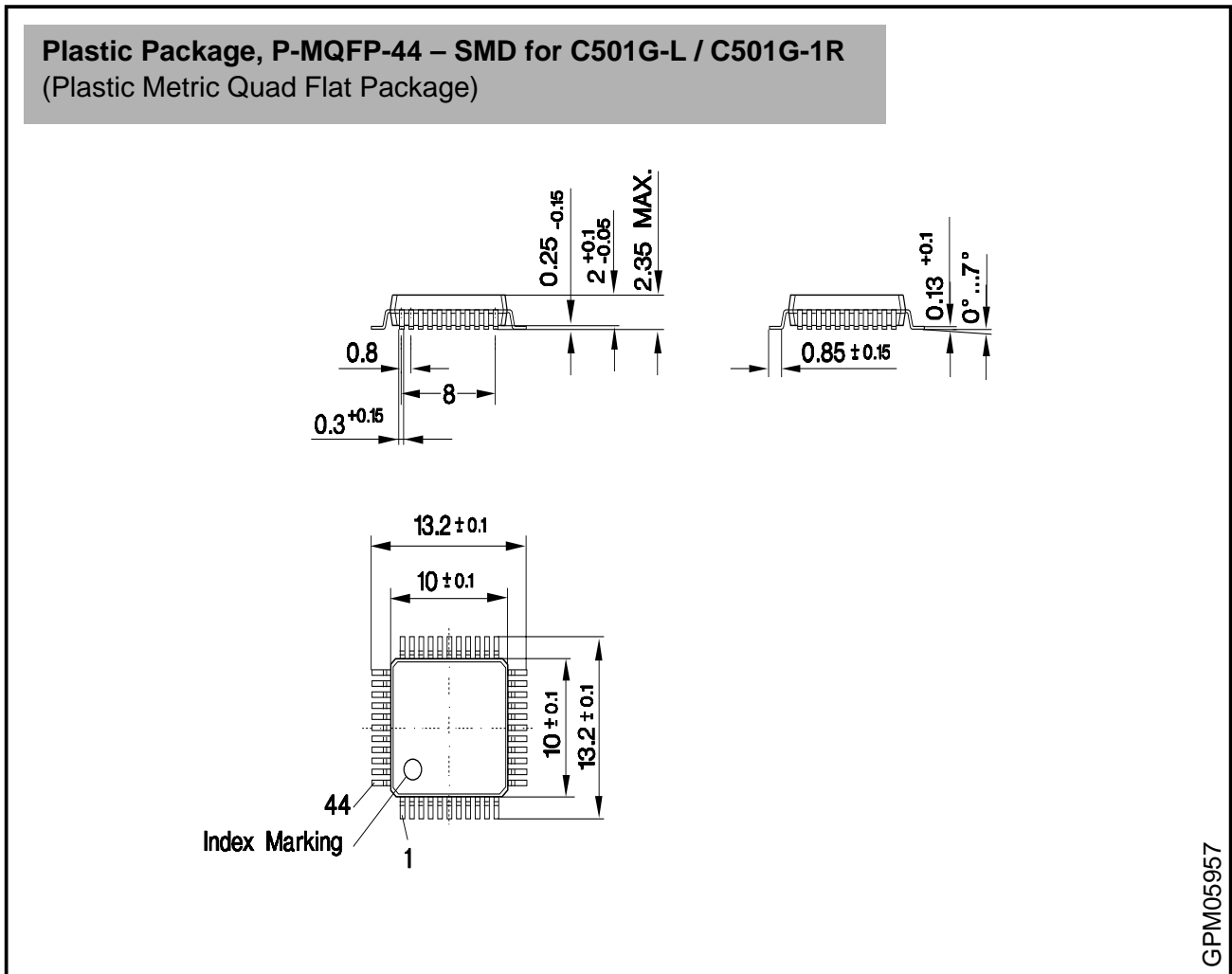

**Figure 24**  
**P-MQFP-44 Package Outlines**

**Sorts of Packing**

Package outlines for tubes, trays etc. are contained in our Data Book "Package Information"

SMD = Surface Mounted Device

Dimensions in mm