

REVISIONS

P	LTR	DESCRIPTION	DATE	DWN	APVD
	A1	ECR-21-118569	29NOV2021	SCD	DR

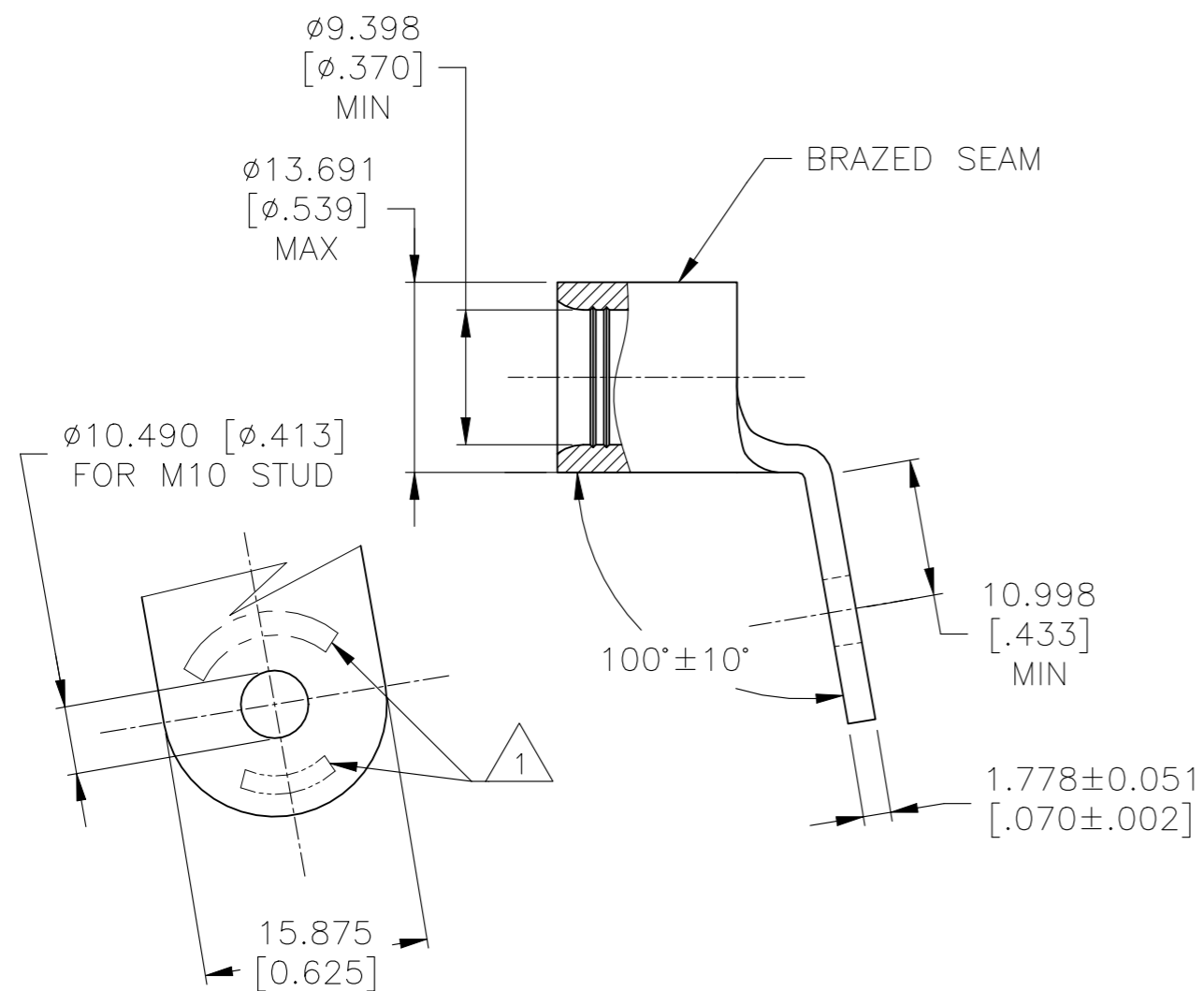

- 1 STAMP: AMP 2W* 60-75 APPROX AS SHOWN.
- 2 MATERIAL: COPPER PER ASTM B152.
- 3 FINISH: NICKEL PLATE 0.00762 [.000300] MIN EXT THK PER SAE AMS QQ-N-290

135480-3	LOOSE PIECE	50
PART NUMBER	PACKAGE TYPE	QTY

MAX. TEMP: 343°C [649°F]	THIS DRAWING IS A CONTROLLED DOCUMENT.		DWN RAGHAVENDRA.K 04APR2020	TE Connectivity				
	VOLTAGE RATING: N/A	DIMENSIONS: mm [INCHES]	TOLERANCES UNLESS OTHERWISE SPECIFIED:				CHK DANIEL.R 04APR2020	
CIRCULAR MIL AREA: 26.7-42.4 MM ² [52,600-83,700] SOLID OR STRANDED	MATERIAL 2	FINISH 3	APVD DANIEL.R 04APR2020	NAME	TERMINAL RING TONGUE STRATO-THERM, HEAT RESISTANT WIRE SIZE: 2 AWG, 100 DEG BEND			
			PRODUCT SPEC	APPLICATION SPEC	SIZE	CAGE CODE	DRAWING NO	RESTRICTED TO
				114-2162	A3	00779	C-135480	-
			CUSTOMER DRAWING	SCALE	NTS	SHEET	1 OF 1	REV A1