

T-43-15-00



DM74AS20 Dual 4-Input NAND Gate

General Description

This device contains two independent gates, each of which performs the logic NAND function.

Features

- Switching specifications at 50 pF
- Switching specifications guaranteed over full temperature and V_{CC} range

- Advanced oxide-isolated, ion-implanted Schottky TTL process
- Functionally and pin for pin compatible with Schottky, low power Schottky, and advanced low power Schottky TTL counterpart
- Improved AC performance over Schottky, low power Schottky, and advanced low power Schottky counterparts

Connection Diagram

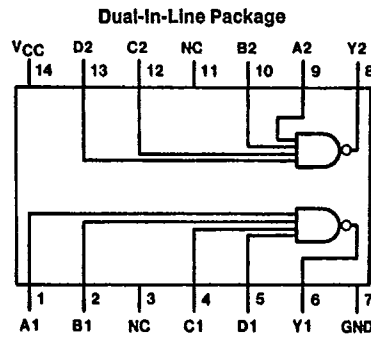

TL/F/6276-1

Order Number DM74AS20M or DM74AS20N
See NS Package Number M14A or N14A

Function Table

$$Y = \overline{ABCD}$$

Inputs				Output
A	B	C	D	Y
X	X	X	L	H
X	X	L	X	H
X	L	X	X	H
L	X	X	X	H
H	H	H	H	L

H = High Logic Level
L = Low Logic Level
X = Either Low or High Logic Level



Absolute Maximum Ratings

Supply Voltage	7V
Input Voltage	7V
Operating Free Air Temperature Range	0°C to +70°C
Storage Temperature Range	-65°C to +150°C
Typical θ_{JA}	
N Package	84.0°C/W
M Package	114.0°C/W

T-43-15

Note: The "Absolute Maximum Ratings" are those values beyond which the safety of the device cannot be guaranteed. The device should not be operated at these limits. The parametric values defined in the "Electrical Characteristics" table are not guaranteed at the absolute maximum ratings. The "Recommended Operating Conditions" table will define the conditions for actual device operation.

Recommended Operating Conditions

Symbol	Parameter	Min	Nom	Max	Units
V _{CC}	Supply Voltage	4.5	5.	5.5	V
V _{IH}	High Level Input Voltage	2			V
V _{IL}	Low Level Input Voltage			0.8	V
I _{OH}	High Level Output Current			-2	mA
I _{OL}	Low Level Output Current			20	mA
T _A	Free Air Operating Temperature	0		70	°C

Electrical Characteristics

over recommended operating free air temperature range. All typical values are measured at V_{CC} = 5V, T_A = 25°C.

Symbol	Parameter	Conditions	Min	Typ	Max	Units
V _{IK}	Input Clamp Voltage	V _{CC} = 4.5V, I _I = -18 mA			-1.2	V
V _{OH}	High Level Output Voltage	I _{OH} = -2 mA V _{CC} = 4.5V to 5.5V	V _{CC} - 2			V
V _{OL}	Low Level Output Voltage	V _{CC} = 4.5V, I _{OL} = 20 mA		0.35	0.5	V
I _I	Input Current @ Max Input Voltage	V _{CC} = 5.5V, V _{IH} = 7V			0.1	mA
I _{IH}	High Level Input Current	V _{CC} = 5.5V, V _{IH} = 2.7V			20	μA
I _{IL}	Low Level Input Current	V _{CC} = 5.5V, V _{IL} = 0.4V			-0.5	mA
I _O	Output Drive Current	V _{CC} = 5.5V, V _O = 2.25V	-30		-112	mA
I _{CC}	Supply Current	V _{CC} = 5.5V				
		Outputs High		1.1	1.6	mA
		Outputs Low		6	8.7	mA

Switching Characteristics over recommended operating free air temperature range (Note 1)

Symbol	Parameter	Conditions	Min	Max	Units
t _{PLH}	Propagation Delay Time Low to High Level Output	V _{CC} = 4.5V to 5.5V R _L = 500Ω C _L = 50 pF	1	5	ns
t _{PHL}	Propagation Delay Time High to Low Level Output		1	4.5	ns

Note 1: See Section 1 for test waveforms and output load.