

42M SERIES

**FASTEST, MOST FLEXIBLE
DESIGN RESPONSE****GENERAL SPECIFICATIONS**

Step Angle	7.5°
Step Accuracy	± 0.5°
Operating Temperature	100°C Max
Ambient Temperature Range	-20°C ~ +70°C
Insulation Resistance at 500Vdc	100MΩ
Dielectric Withstanding Voltage	650 ± 50 VRMS, 2 sec

 [CLICK HERE TO PRINT THIS SERIES](#)
OPENS PDF IN NEW WINDOW

The specifications in this publication are believed to be accurate and reliable. However, it is the responsibility of the product user to determine the suitability of Portescap products for a specific application. While defective products will be replaced without charge if promptly returned, no liability is assumed beyond such replacement.

Portescap Danaher Motion motors will not be CE marked where the Low Voltage Directive, the Electro-Magnetic Compatibility or other appropriate EU directives are not applicable - this is an EU legal requirement.

TECHNICAL SPECIFICATIONS

	UNIPOLAR		BIPOLAR	
Part Number	42M048C1U-N	42M048C2U-N	42M048C1B-N	42M048C2B-N
DC Operating Voltage	5	12	5	12
Resistance per Winding (ohms)	9.1	52.4	9.1	52.4
Inductance per Winding (mH)	8.1	51.7	16.7	85.7
Holding Torque* (mNm/oz-in)	66.2 / 9.4	66.2 / 9.4	84.0 / 11.9	84.0 / 11.9
Rotor Moment of Inertia (g.m ²)	12.5 x 10 ⁻⁴	12.5 x 10 ⁻⁴	12.5 x 10 ⁻⁴	12.5 x 10 ⁻⁴
Detent Torque (mNm/oz-in)	12.7 / 1.80	12.7 / 1.80	12.7 / 1.80	12.7 / 1.80
Step Angle	7.5°	7.5°	7.5°	7.5°
Step Angle Tolerance*	± 0.5°	± 0.5°	± 0.5°	± 0.5°
Steps per Revolution*	48	48	48	48
Max. Operating Temperature	100°C	100°C	100°C	100°C
Ambient Temperature Range				
Operating	-20°C to 70°C	-20°C to 70°C	-20°C to 70°C	-20°C to 70°C
Storage	-40°C to 85°C	-40°C to 85°C	-40°C to 85°C	-40°C to 85°C
Bearing Type	Sintered bronze sleeve	Sintered bronze sleeve	Sintered bronze sleeve	Sintered bronze sleeve
Insulation Resistance at 500Vdc	100 megohms	100 megohms	100 megohms	100 megohms
Dielectric Withstanding Voltage	650 ± 50 VRMS, 2 sec	650 ± 50 VRMS, 2 sec	650 ± 50 VRMS, 2 sec	650 ± 50 VRMS, 2 sec
Weight (g/oz)	145 / 5.1	145 / 5.1	145 / 5.1	145 / 5.1
Leadwires	26 AWG, UL Style 1430	26 AWG, UL Style 1430	26 AWG, UL Style 1430	26 AWG, UL Style 1430

* Measured with 2 phases energized

MECHANICAL DIMENSIONS

UNITS = MM / INCHES

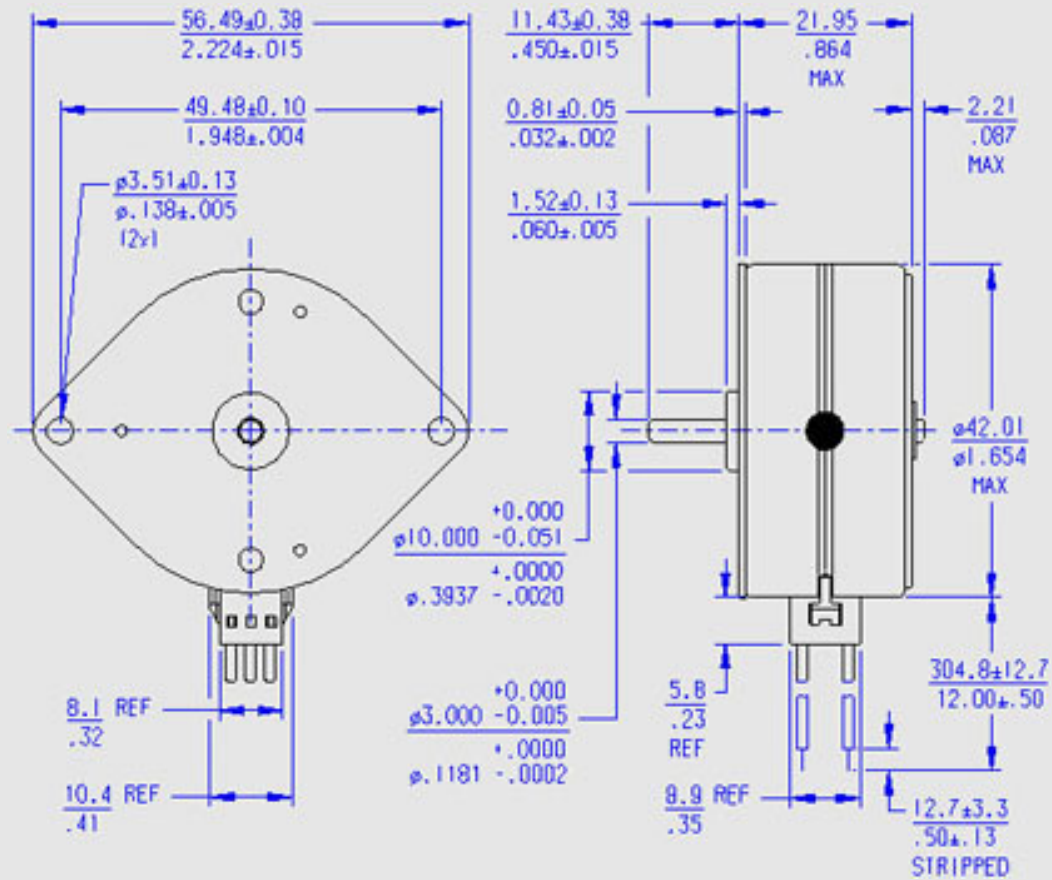

WIRING DIAGRAM

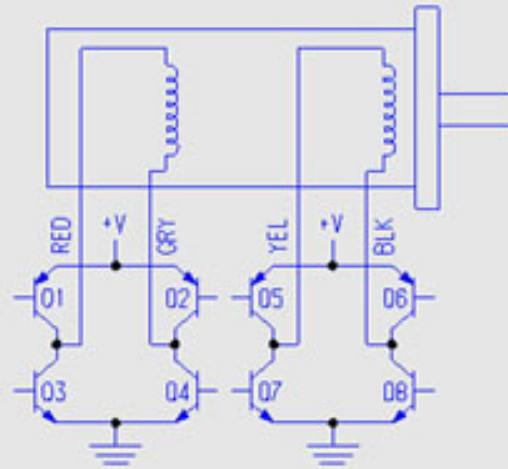

BIPOLAR

	STEP	01-04	02-03	05-08	06-07
↓ CW ROTATION	1	ON	OFF	ON	OFF
	2	ON	OFF	OFF	ON
	3	OFF	ON	OFF	ON
	4	OFF	ON	ON	OFF
	1	ON	OFF	ON	OFF
↑ CCW ROTATION					

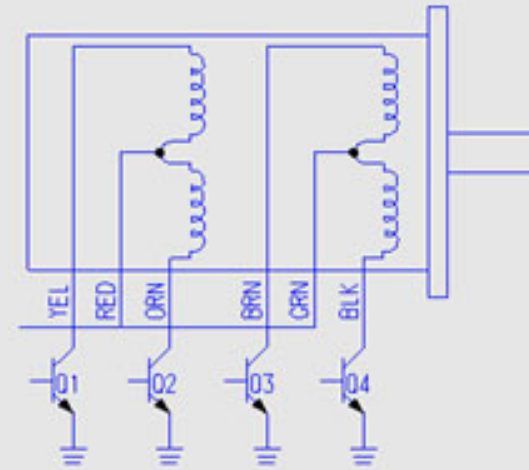

UNIPOLAR

	STEP	01	02	03	04
↓ CW ROTATION	1	ON	OFF	ON	OFF
	2	ON	OFF	OFF	ON
	3	OFF	ON	OFF	ON
	4	OFF	ON	ON	OFF
	1	ON	OFF	ON	OFF
↑ CCW ROTATION					

MOTOR DYNAMICS

CLICK ON A THUMBNAIL TO MAGNIFY

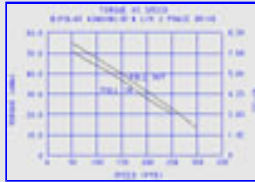

42M048C1B, Bipolar,
L/R Drive

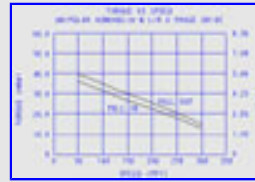

42M048C1U, Unipolar,
L/R Drive

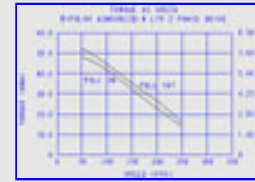

42M048C2B, Bipolar,
L/R Drive

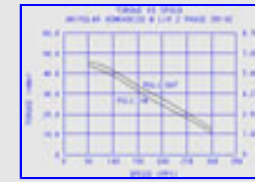

42M048C2U, Unipolar,
L/R Drive



42M048C1B, Bipolar,
Chopper Drive

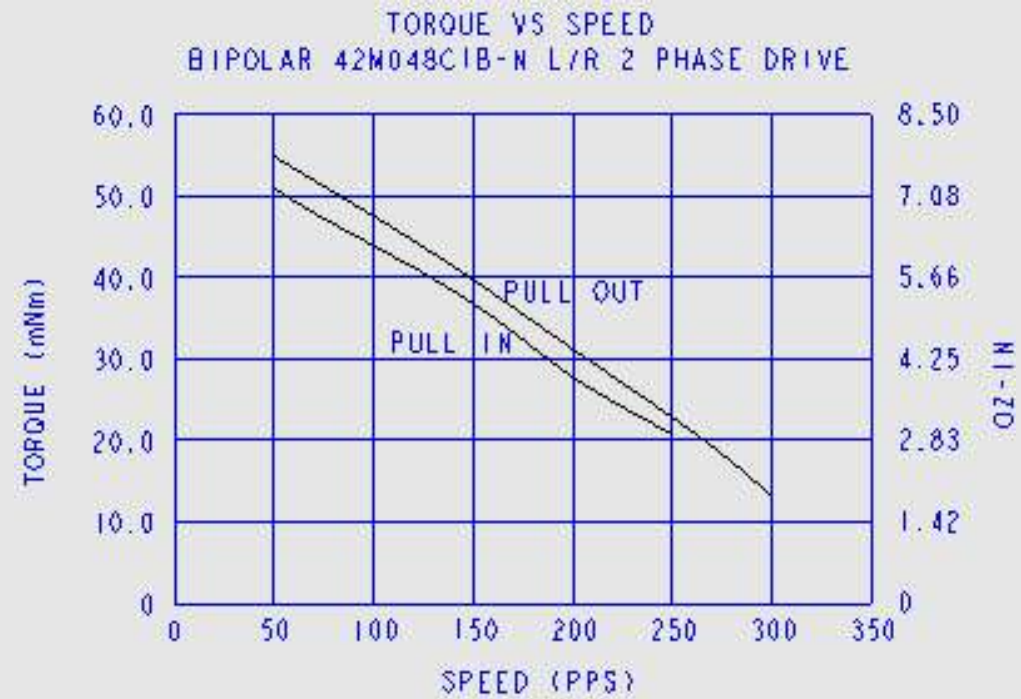

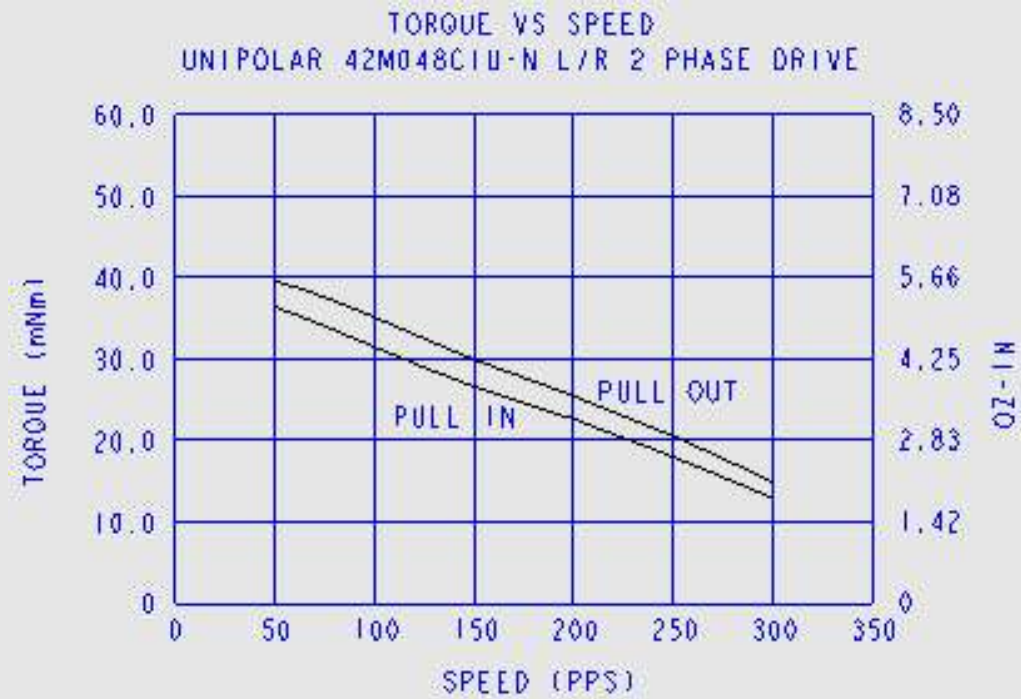

MOTOR DYNAMICS



CHART INDEX

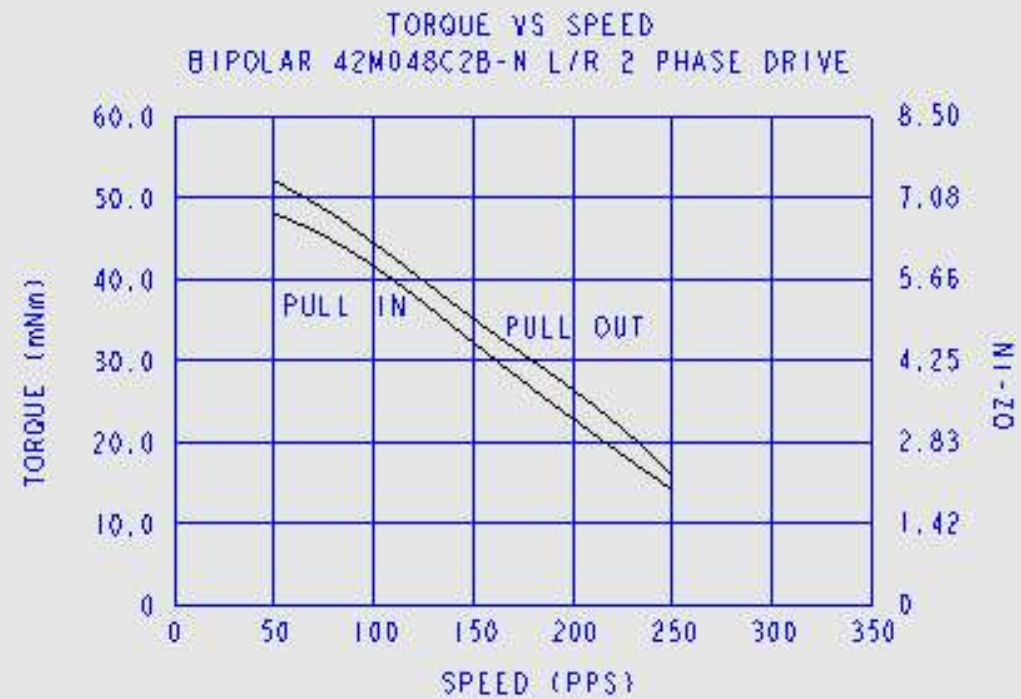

MOTOR DYNAMICS



CHART INDEX

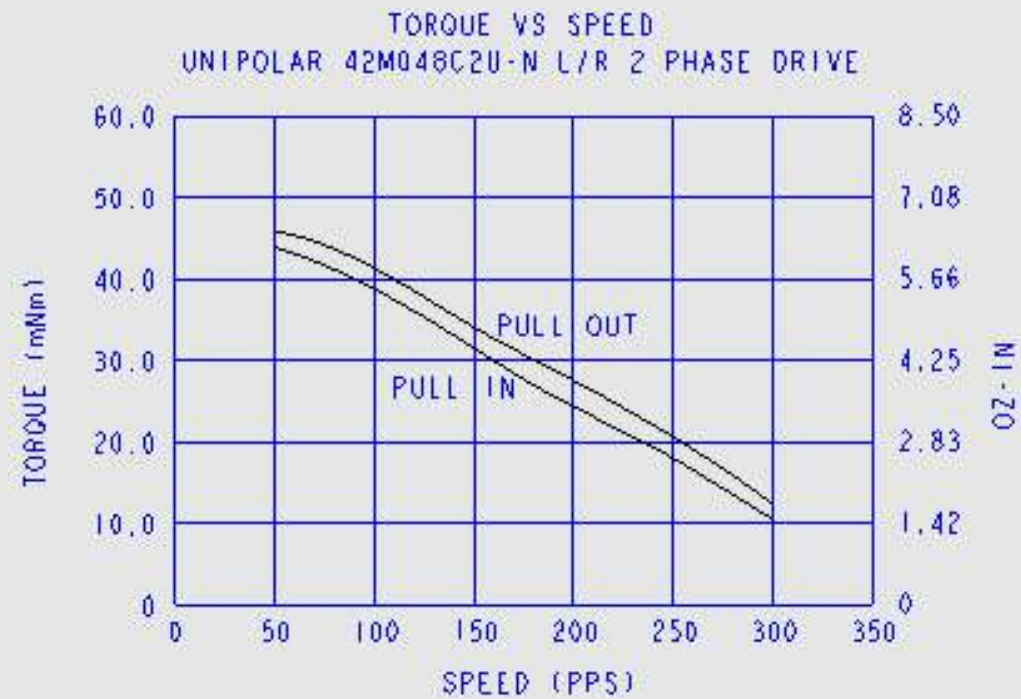



TORQUE VS SPEED

BIPOLAR 42M048CIB-N CHOPPER DRIVE
@ 36V, 350mA/ϕ, 2ϕ

