



CY8CKIT-022

CapSense Liquid Level Sensing Shield Kit Guide

Doc. #: 002-09825 Rev. *D

Cypress Semiconductor
198 Champion Court
San Jose, CA 95134-1709
www.cypress.com

Copyrights

© Cypress Semiconductor Corporation, 2015–2020. This document is the property of Cypress Semiconductor Corporation and its subsidiaries (“Cypress”). This document, including any software or firmware included or referenced in this document (“Software”), is owned by Cypress under the intellectual property laws and treaties of the United States and other countries worldwide. Cypress reserves all rights under such laws and treaties and does not, except as specifically stated in this paragraph, grant any license under its patents, copyrights, trademarks, or other intellectual property rights. If the Software is not accompanied by a license agreement and you do not otherwise have a written agreement with Cypress governing the use of the Software, then Cypress hereby grants you a personal, non-exclusive, nontransferable license (without the right to sublicense) (1) under its copyright rights in the Software (a) for Software provided in source code form, to modify and reproduce the Software solely for use with Cypress hardware products, only internally within your organization, and (b) to distribute the Software in binary code form externally to end users (either directly or indirectly through resellers and distributors), solely for use on Cypress hardware product units, and (2) under those claims of Cypress’s patents that are infringed by the Software (as provided by Cypress, unmodified) to make, use, distribute, and import the Software solely for use with Cypress hardware products. Any other use, reproduction, modification, translation, or compilation of the Software is prohibited.

TO THE EXTENT PERMITTED BY APPLICABLE LAW, CYPRESS MAKES NO WARRANTY OF ANY KIND, EXPRESS OR IMPLIED, WITH REGARD TO THIS DOCUMENT OR ANY SOFTWARE OR ACCOMPANYING HARDWARE, INCLUDING, BUT NOT LIMITED TO, THE IMPLIED WARRANTIES OF MERCHANTABILITY AND FITNESS FOR A PARTICULAR PURPOSE. No computing device can be absolutely secure. Therefore, despite security measures implemented in Cypress hardware or software products, Cypress shall have no liability arising out of any security breach, such as unauthorized access to or use of a Cypress product. CYPRESS DOES NOT REPRESENT, WARRANT, OR GUARANTEE THAT CYPRESS PRODUCTS, OR SYSTEMS CREATED USING CYPRESS PRODUCTS, WILL BE FREE FROM CORRUPTION, ATTACK, VIRUSES, INTERFERENCE, HACKING, DATA LOSS OR THEFT, OR OTHER SECURITY INTRUSION (collectively, “Security Breach”). Cypress disclaims any liability relating to any Security Breach, and you shall and hereby do release Cypress from any claim, damage, or other liability arising from any Security Breach. In addition, the products described in these materials may contain design defects or errors known as errata which may cause the product to deviate from published specifications. To the extent permitted by applicable law, Cypress reserves the right to make changes to this document without further notice. Cypress does not assume any liability arising out of the application or use of any product or circuit described in this document. Any information provided in this document, including any sample design information or programming code, is provided only for reference purposes. It is the responsibility of the user of this document to properly design, program, and test the functionality and safety of any application made of this information and any resulting product. “High-Risk Device” means any device or system whose failure could cause personal injury, death, or property damage. Examples of High-Risk Devices are weapons, nuclear installations, surgical implants, and other medical devices. “Critical Component” means any component of a High-Risk Device whose failure to perform can be reasonably expected to cause, directly or indirectly, the failure of the High-Risk Device, or to affect its safety or effectiveness. Cypress is not liable, in whole or in part, and you shall and hereby do release Cypress from any claim, damage, or other liability arising from any use of a Cypress product as a Critical Component in a High-Risk Device. You shall indemnify and hold Cypress, its directors, officers, employees, agents, affiliates, distributors, and assigns harmless from and against all claims, costs, damages, and expenses, arising out of any claim, including claims for product liability, personal injury or death, or property damage arising from any use of a Cypress product as a Critical Component in a High-Risk Device. Cypress products are not intended or authorized for use as a Critical Component in any High-Risk Device except to the limited extent that (i) Cypress’s published data sheet for the product explicitly states Cypress has qualified the product for use in a specific High-Risk Device, or (ii) Cypress has given you advance written authorization to use the product as a Critical Component in the specific High-Risk Device and you have signed a separate indemnification agreement.

Cypress, the Cypress logo, Spansion, the Spansion logo, and combinations thereof, WICED, PSoC, CapSense, EZ-USB, F-RAM, and Traveo are trademarks or registered trademarks of Cypress in the United States and other countries. For a more complete list of Cypress trademarks, visit cypress.com. Other names and brands may be claimed as property of their respective owners.

Contents



Safety Information	5
1. Introduction	7
1.1 Kit Contents	7
1.2 Getting Started.....	8
1.3 Additional Resources.....	9
1.4 Hardware Requirements.....	9
1.5 Software Requirements	10
1.5.1 PSoC Creator.....	10
1.5.2 PSoC Programmer.....	10
1.6 Application Notes and Projects.....	10
1.7 Technical Support.....	10
1.8 Documentation Conventions.....	11
1.9 Acronyms.....	11
2. Kit Hardware	12
2.1 Board Details	12
2.2 Kit Assembly	15
2.3 Theory of Operation.....	17
2.3.1 Principle of Capacitive Liquid Level Sensing	17
2.3.2 CY8CKIT-022 Kit.....	18
2.4 Functional Description	19
2.4.1 Two Sensor Flexible PCB	19
2.4.2 12 Sensor Flexible PCB.....	19
2.4.3 Flexible Sensor Connector.....	20
2.4.4 Arduino-Compatible Headers.....	20
2.4.5 Temperature Compensation Sensor	22
2.4.6 Integration Capacitors	22
2.4.7 UART Connection	23
2.4.8 Liquid Container	23
3. Example Projects	24
4. Design Support	25

A. Appendix	26
A.1 Shield Schematic	26
A.2 2RX Sensor Schematic.....	27
A.3 12RX Sensor Schematic.....	28
A.4 Shield Layout	29
A.5 2RX Sensor Layout.....	30
A.6 12RX Sensor Layout.....	31
A.7 Bill of Materials	32
 Revision History	 33

Safety Information



Regulatory Compliance

The CapSense Liquid Level Sensing Shield Kit ([CY8CKIT-022](#)) is intended for use as a development platform for hardware or software in a laboratory environment. The board is an open system design, which does not include a shielded enclosure. This may cause interference to other electrical or electronic devices in close proximity. In a domestic environment, this product may cause radio interference. In such cases, you may be required to take adequate preventive measures. In addition, this board should not be used near any medical equipment or RF devices.

Attaching additional wiring to this product or modifying the product operation from the factory default may affect its performance and cause interference with other apparatus in the immediate vicinity. If such interference is detected, suitable mitigating measures should be taken.

The Liquid Level Sensing Shield Kit, as shipped from the factory, has been verified to meet with the requirements of CE as a Class A product.



The Liquid Level Sensing Shield Kit contains ESD-sensitive devices. Electrostatic charges readily accumulate on the human body and any equipment, and can discharge without detection. Permanent damage may occur on devices subjected to high-energy discharges. Proper ESD precautions are recommended to avoid performance degradation or loss of functionality. Store unused kit boards in the protective shipping package.



End-of-Life/Product Recycling

This kit has an end-of life five years from the date of manufacture mentioned on the back of the box. Contact your nearest recycler for discarding the kit.

General Safety Instructions

ESD Protection

ESD can damage boards and associated components. Cypress recommends that you perform procedures only at an ESD workstation. If such a workstation is not available, use appropriate ESD protection by wearing an antistatic wrist strap attached to the chassis ground (any unpainted metal surface) on your board when handling parts.

Handling Boards

[CY8CKIT-022](#) boards are sensitive to ESD. Hold the board only by its edges. Do not slide the board over any surface.

1. Introduction



Thank you for your interest in the CapSense® Liquid Level Sensing Shield Kit (CY8CKIT-022). This kit is intended to demonstrate the Liquid Level Sensing (LLS) capabilities of the CapSense technology in Cypress's PSoC® 4 products.

This kit supports the following liquid level sensing features:

- Non-contact measurement of liquid levels from sensors located on the exterior of the non-conductive liquid container. Avoids contamination and cleaning issues found with mechanical and contact sensors, simplifying industrial design and improving user experience.
- Supports two different sensor patterns. A two sensor 'Backgammon' shaped pattern provides liquid level sensing at a low cost point while a multi sensor 'Segmented' pattern provides increased accuracy that can be optimized for each design by varying the number and shape of sensors.

This kit guide provides details on the kit contents, hardware, schematics, and BOM. See Code Example [CE202479](#) for example projects developed for use with this kit and [AN202478 - PSoC 4 - Capacitive Liquid Level Sensing](#) for theory, design guidance, and sensor layout information.

1.1 Kit Contents

The CapSense Liquid Level Sensing Shield Kit contains the following, as shown in [Figure 1-1](#).

- CapSense® Liquid Level Sensing Shield board
- CapSense Liquid Level Sensing 12 Sensor Flex PCB
- CapSense Liquid Level Sensing 2 Sensor Flex PCB
- Liquid container
- Quick Start Guide

Figure 1-1. Kit Contents



Inspect the contents of the kit; if you find any part missing, contact your nearest [Cypress sales office](#) for help.

1.2 Getting Started

This guide will help you get acquainted with the CapSense Liquid Level Sensing Shield Kit:

- The [Kit Hardware](#) chapter on page 12 describes how to assemble and use the kit’s resources.
- The [Example Projects](#) chapter on page 24 provides the major features of the Liquid Level Sensing Shield Kit.
- The [Design Support](#) chapter on page 25 provides information on documents and resources required to start new liquid level sensing designs with PSoC 4 CapSense.
- The [Appendix](#) chapter on page 26 provides detailed hardware description, schematics, and bill of materials (BOM).

1.3 Additional Resources

Cypress provides a wealth of data at www.cypress.com to help you select the right PSoC device for your design, and to help you to quickly and effectively integrate the device into your design. For a comprehensive list of resources, visit <http://www.cypress.com/psoc>. The web page includes a list of PSoC device families, integrated design environments (IDEs), and associated development kits. In addition, refer to the following documents to get started with PSoC 4 devices and CapSense technology:

- [AN79953 - Getting Started with PSoC® 4](#)
- [Getting Started with CapSense®](#)
- [PSoC® 4 CapSense® Design Guide](#)
- [AN202478 - PSoC 4 - Capacitive Liquid Level Sensing](#)
- [CE202479 - Code Example for Liquid Level Sensing](#)
- [PSoC 101 Training Series](#)

1.4 Hardware Requirements

[CY8CKIT-022](#) plugs into any Arduino™ hardware-compatible development platform from Cypress. [CE202479](#) provides example projects targeting the [CY8CKIT-042 PSoC 4 Pioneer Kit](#).

[Figure 1-2](#) shows how the [CY8CKIT-022](#) kit connects to the [CY8CKIT-042](#) kit.

Visit <http://www.cypress.com/CY8CKIT-042> to purchase the CY8CKIT-042 kit.

Figure 1-2. CY8CKIT-022 Connected to CY8CKIT-042



1.5 Software Requirements

The [CY8CKIT-022](#) kit does not have any programmable/configurable devices onboard, so it does not need any software for configuration. However, the PSoC device present on the [CY8CKIT-042](#) baseboard requires firmware which you can develop with the [PSoC Creator IDE](#) (Version 3.3 CP1 or later).

1.5.1 PSoC Creator

[PSoC Creator](#) allows concurrent hardware and application firmware design of PSoC 3, PSoC 4, and PSoC 5LP systems. PSoC systems are designed using classic, familiar, schematic-capture technology supported by pre-verified, production-ready PSoC Components™.

PSoC Components are analog and digital virtual chips represented by icons that you can drag and drop into a design and configure to suit a broad array of application requirements. You can configure each Component in the rich, mixed-signal Cypress Component Catalog with the Component Customizer tool. These Components include a full set of dynamically generated API libraries. After you have configured the PSoC system, you can write, compile, and debug the firmware within PSoC Creator, or export the firmware to other IDEs such as those from IAR, Keil, and Eclipse.

You can download the latest version of the PSoC Creator software from <http://www.cypress.com/psoccreator>. Refer to the Release Notes for the minimum and recommended system requirements.

1.5.2 PSoC Programmer

The PSoC Programmer software is used to program the PSoC devices on the [CY8CKIT-042](#) kit with hex files. You can download PSoC Programmer at <http://www.cypress.com/go/psocprogrammer>.

1.6 Application Notes and Projects

- [AN202478 - PSoC 4 - Capacitive Liquid Level Sensing](#) provides detailed theory, design guidance, and sensor layout information for explaining this kits operation as well as developing a new liquid level sensing design.
- [CE202479](#) contains example projects that demonstrate the following features of the [CY8CKIT-022](#) kit:
 - Liquid level measurement using capacitive sensors
 - Two sensor (2RX) project for use with the low cost 2RX flexible sensor
 - Twelve sensor (12RX) project for use with the increased accuracy 12RX flexible sensor
 - See the [Appendix chapter on page 26](#) in this kit guide for details.

1.7 Technical Support

For assistance, visit [Cypress Support](#) or contact customer support at +1 (800) 541-4736 Ext. 2 (in the USA) or +1 (408) 943-2600 Ext. 2 (International).

You can also use the following support resources if you need quick assistance:

- [Self-help \(Technical Documents\)](#)
- [Local Sales Office Locations](#)

1.8 Documentation Conventions

Table 1-1. Document Conventions for Guides

Convention	Usage
Courier New	Displays file locations, user entered text, and source code: C:\...cd\icc\
<i>Italics</i>	Displays file names and reference documentation: Read about the <i>sourcefile.hex</i> file in the <i>PSoC Designer User Guide</i> .
[Bracketed, Bold]	Displays keyboard commands in procedures: [Enter] or [Ctrl] [C]
File > Open	Represents menu paths: File > Open > New Project
Bold	Displays commands, menu paths, and icon names in procedures: Click the File icon and then click Open .
Times New Roman	Displays an equation: $2 + 2 = 4$
Text in gray boxes	Describes Cautions or unique functionality of the product.

1.9 Acronyms

Table 1-2. Acronyms Used in the Document

Acronym	Description
LLS	Liquid Level Sensing
C_L	Liquid Capacitance
C_P	Parasitic Capacitance
GND	Ground
IDE	Integrated Design Environment
PCB	Printed Circuit Board
IO	Input Output Pin
USB	Universal Serial Bus
UART	Universal Asynchronous Receiver/Transmitter
PET	Polyethylene Terephthalate

2. Kit Hardware



2.1 Board Details

The [CY8CKIT-022](#) kit contains the following components:

- CapSense® Liquid Level Sensing Shield board
 - Arduino-compatible headers to interface the Cypress PSoC 4 Pioneer Kit pins to the flexible liquid sensor connector pins
 - Connects PSoC 4 Pioneer UART pins to Pioneer KitProg UART pins
 - Optional temperature compensation sensor
- CapSense Liquid Level Sensing 2 Sensor Flex PCB
 - Low cost design provides two sensors (RX0, RX1) for liquid level measurement and a ground plane (TX0) to improve signal uniformity
- CapSense Liquid Level Sensing 12 Sensor Flex PCB
 - Higher accuracy design provides 12 sensors (RX[0:11]) for liquid measurement

[Figure 2-1](#) through [Figure 2-4](#) show the top and bottom views of the [CY8CKIT-022](#) board.

Figure 2-1. CY8CKIT-022 Shield Board (Top View)

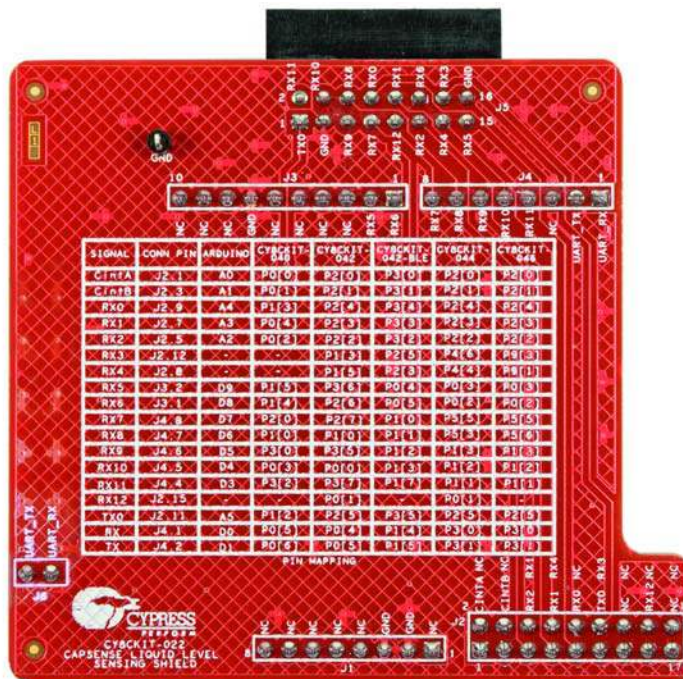

Figure 2-2. CY8CKIT-022 Shield Board (Bottom View)



Figure 2-3. Top View of both CY8CKIT-022 Sensors

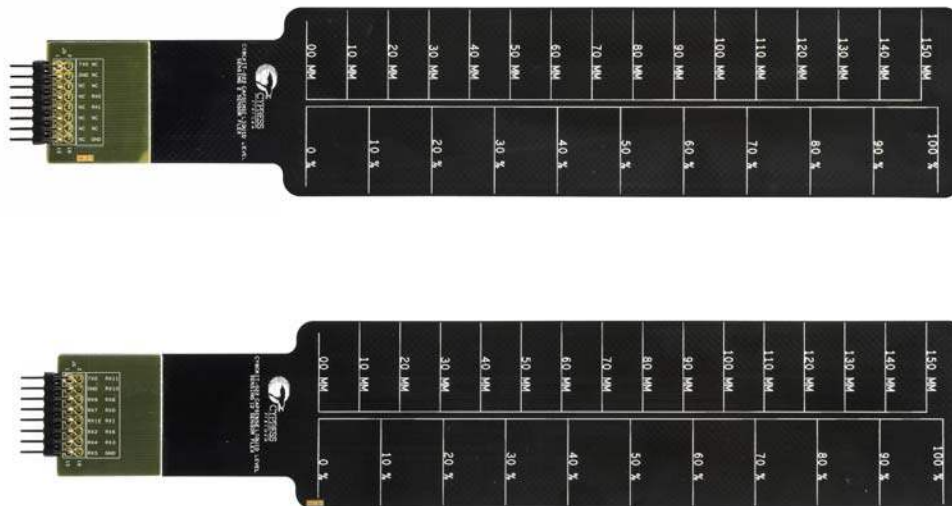
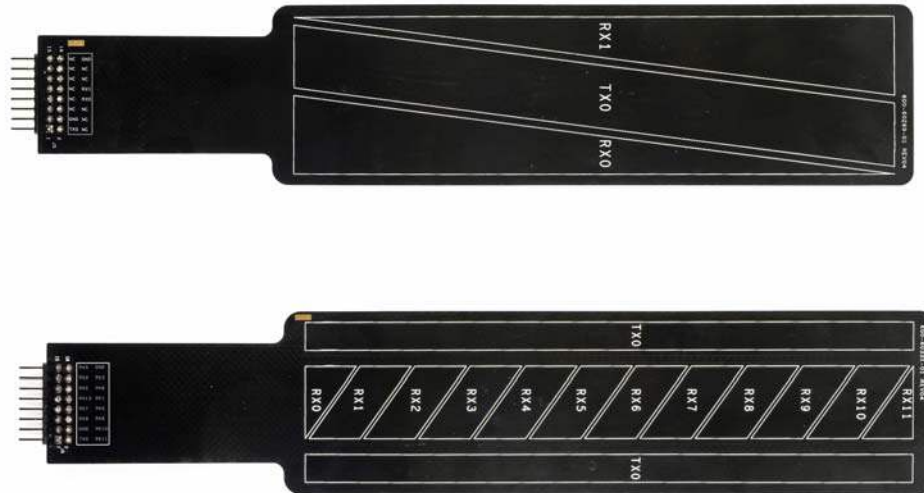

Figure 2-4. Bottom View of both CY8CKIT-022 Sensors



2.2 Kit Assembly

Follow these assembly steps to operate the kit:

1. Remove the adhesive sticker from the back of one of the CapSense Liquid Level Sensor Flex PCB and then paste the sensor onto the liquid container, as shown in [Figure 2-5](#). Center the sensor on one of the flat sides so the top of the sensor is aligned with the top of the flat section. This placement will result in the 0 mm (0%) line on the sensor being approximately 15 mm from the bottom of the container.

Note If the sensor flex is placed too low on the container, the radius of bend on the flex tail may cause the container to become unstable.

Figure 2-5. Placing the Sensor



2. Thoroughly press the entire sensor area to the container to ensure there are no air bubbles in the adhesive layer. Air bubbles allow the distance between the sensor and the liquid to fluctuate. Distance changes cause changes to the sensor's capacitance resulting in reduced liquid level accuracy. Air bubbles can be observed through the adhesive layer on the back of the sensor through the bottle.

3. Connect the CapSense Liquid Level Sensing Shield onto the CY8CKIT-042 PSoC 4 Pioneer Kit Arduino header, as shown in [Figure 2-6](#), and confirm if the PSoC 4 Pioneer kits jumpers are in default positions.

Figure 2-6. Kit Connections



4. Connect the CapSense Liquid Level Sensing Flex PCB to the CapSense Liquid Level Sensing Shield.
5. Connect the CY8CKIT-042 to your PC using the provided USB cable.
6. Compatible firmware and operating instructions are provided in code example [CE202479](#).

2.3 Theory of Operation

For a detailed explanation on the theory of operation of this kit, refer to [AN202478 - PSoC 4 - Capacitive Liquid Level Sensing](#).

This section provides a high-level description of the principle of capacitive sensing and describes where the CY8CKIT-022 kit and PSoC devices fit in a capacitive liquid level sensing system.

2.3.1 Principle of Capacitive Liquid Level Sensing

Capacitive liquid level sensors are conductive pads or traces laid on non-conductive material such as PCB, plastic, or glass. The intrinsic capacitance of the PCB trace, pads, and other connections to the sensor results in a sensor parasitic capacitance (C_P). When a capacitive sensor is excited by a voltage source, an electric field is created around the sensor. A small number of electric field lines couple with the nearby ground, while most of the electric field lines are projected into the nearby space of the liquid container, as shown in [Figure 2-7](#).

When a target object such as water approaches the sensor, the electric field couples with it and adds small amount of liquid capacitance (C_L) to the existing C_P , as shown in [Figure 2-8](#). The capacitive liquid level sensing technique involves measuring this change in the capacitance of a sensor when water is near the sensor.

Figure 2-7. Capacitance and Electric Field of a Capacitive Liquid Level Sensor

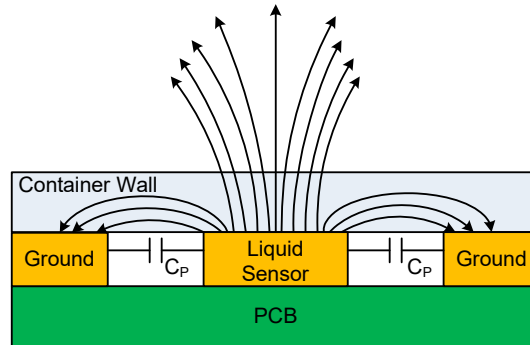
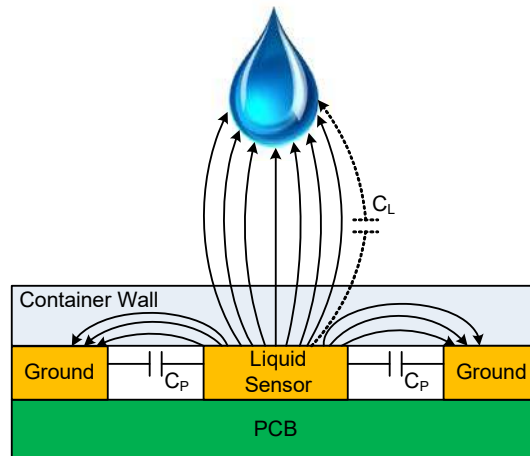

Figure 2-8. Added Capacitance (C_L) When Liquid Approaches a Capacitive Sensor



2.3.2 CY8CKIT-022 Kit

The [CY8CKIT-022](#) kit contains capacitive sensors attached to a liquid container. These sensors can be interfaced with PSoC 4 devices present on Cypress PSoC 4 Pioneer Kits through Arduino-compatible headers, as shown in [Figure 2-9](#).

Figure 2-9. CY8CKIT-022 System Block Diagram

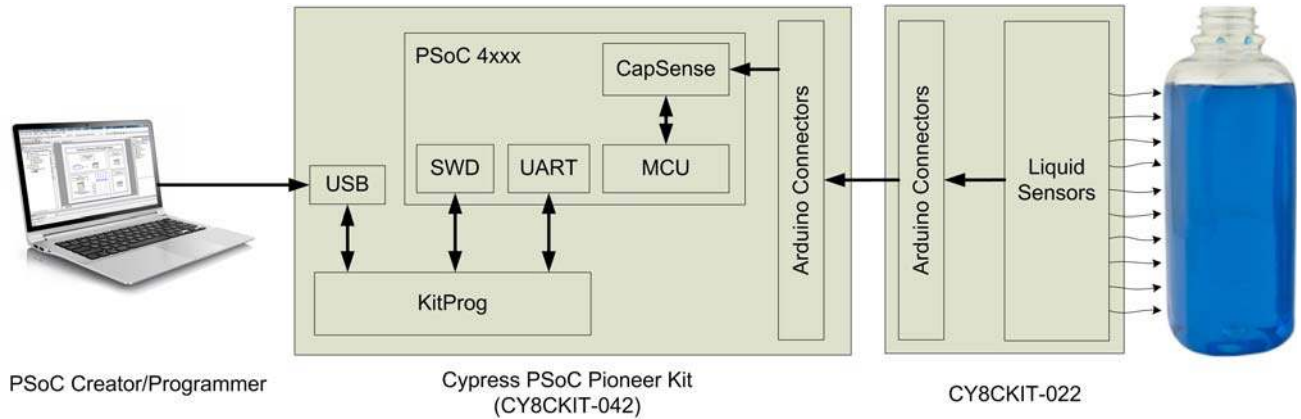

In the [CY8CKIT-022](#) system, the CapSense circuitry in the PSoC device on the baseboard (such as [CY8CKIT-042](#)) senses the changes in the capacitance of the liquid level sensors on the [CY8CKIT-022](#) kit. The PSoC calculates the liquid level based on the information about capacitance changes on different sensors received from the CapSense block.

You can program the PSoC device on the baseboard through the onboard KitProg hardware, which communicates to the software programming tool ([PSoC Programmer](#)) through the USB interface on the board. You can develop firmware applications for PSoC 4 devices by using PSoC Creator.

[CE202479](#) provides code example projects that you can use with the [CY8CKIT-022](#) system to implement liquid level sensing solutions.

2.4 Functional Description

2.4.1 Two Sensor Flexible PCB

The signal ratio from the two sensors (RX0 and RX1) provides a low cost method of determining liquid height. The pattern shown in [Figure 2-10](#) is similar to a backgammon game board, and is therefore referred to as the “backgammon” pattern. A third transmitter (TX0) sensor is provided to support the CapSense mutual capacitance scanning method, and can be connected as a CapSense transmitter. If CapSense self capacitance scanning is used, then the TX0 sensor is not required and must be grounded to avoid interfering with the RX0 and RX1 sensors. The flexible PCB comes with a non-conductive double sided adhesive already applied. To use the sensor, it must be adhered to the flat side of the supplied liquid container and attached to the kit shield board.

Figure 2-10. 2RX Sensor Pattern

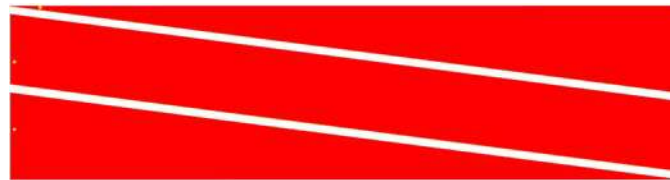

2.4.2 12 Sensor Flexible PCB

Each segment of the 12 sensor (RX[0:11]) pattern shown in [Figure 2-11](#) provides an incremental portion of the total liquid level. While the “segmented” pattern requires additional sensor elements and pin compared to the 2RX version, it allows liquid level resolution to be customized for each design. For use with CapSense self capacitance scanning, only the sensors RX[0:11] must be connected to the PSoC CapSense I/O pins and the TX0 sensor can be left floating or tied to ground. When CapSense mutual capacitance scanning is used, all of the RX and TX sensors must be connected. A small ground plane hatch between the RX and TX sensors is provided to help direct the electrical field into the liquid to increase sensitivity.

Figure 2-11. 12RX Sensor Pattern

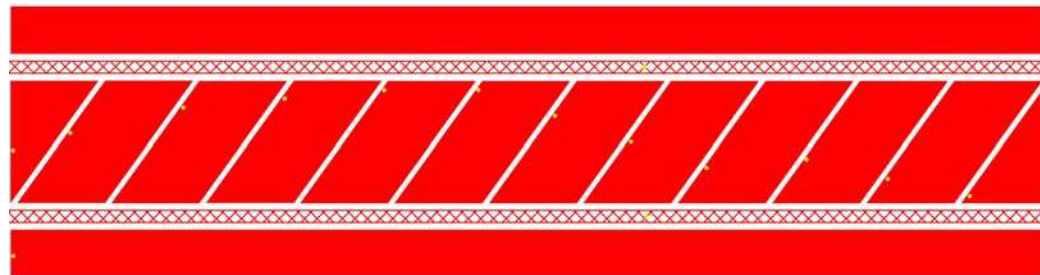

2.4.3 Flexible Sensor Connector

Connector (J5) allows easy connection of sensors to the PSoC on the Pioneer kit. The connector shown in [Figure 2-12](#) provides connection of up to 13 sensors (RX[0:12]). A single transmitter connection (TX0) is provided for use with sensors utilizing the CapSense Mutual-Capacitance Scan method. The TX0 signal includes a 470Ω series resistor to slow edge rates and reduce radiated emissions. The connector can be used with the kit supplied sensors or a custom user created sensor.

Figure 2-12. Sensor Connector

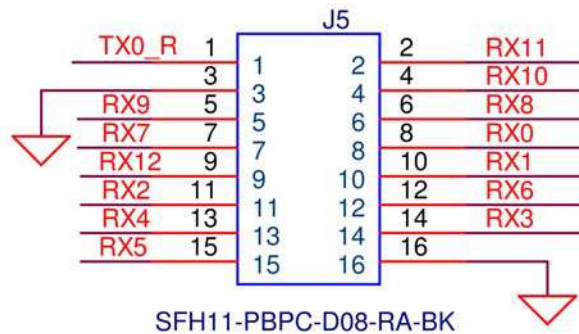

2.4.4 Arduino-Compatible Headers

The I/O headers (J1-J4) comply with the Arduino™ UNO (R3) kit form-factor to support similar form-factor baseboards, as provided in [Table 2-1](#) through [Table 2-4](#).

Table 2-1. J1 Arduino Header or Power Connector

Pin	Arduino Board Signal	CY8CKIT-022	CY8CKIT-042
J1.1	VIN	–	VIN
J1.2	GND	GND	GND
J1.3	GND	GND	GND
J1.4	V5.0	–	V5.0
J1.5	V3.3	–	V3.3
J1.6	RESET	–	RESET
J1.7	IOREF	–	P4.VDD
J1.8	NC	–	–

Table 2-2. J2 Arduino Header

Pin	Arduino Board Signal	CY8CKIT-022	CY8CKIT-042
J2.1	A0	CintA	P2.0
J2.2	–	–	P0.2
J2.3	A1	CintB	P2.1
J2.4	–	–	P0.3
J2.5	A2	RX2	P2.2
J2.6	–	–	VDD
J2.7	A3	RX1	P2.3
J2.8	–	RX4	P1.5
J2.9	A4	RX0	P2.4
J2.10	–	–	P1.4
J2.11	A5	TX0	P2.5
J2.12	–	RX3	P1.3
J2.13	–	–	P0.0
J2.14	–	–	GND
J2.15	–	RX12	P0.1
J2.16	–	–	P1.2
J2.17	–	–	P1.0
J2.18	–	–	P1.1

Table 2-3. J3 Arduino Header

Pin No.	Arduino Board Signal	CY8CKIT-022	CY8CKIT-042
J3.1	D8	RX6	P2.6
J3.2	D9	RX5	P3.6
J3.3	D10	–	P3.4
J3.4	D11	–	P3.0
J3.5	D12	–	P3.1
J3.6	D13	–	P0.6
J3.7	GND	GND	GND
J3.8	AREF	–	P1.7
J3.9	SDA	–	P4.1
J3.10	SCL	–	P4.0

Table 2-4. J4 Arduino Header

Pin No.	Arduino Board Signal	CY8CKIT-022	CY8CKIT-042
J4.1	D0	UART_RX	P0.4
J4.2	D1	UART_TX	P0.5
J4.3	D2	–	P0.7
J4.4	D3	RX11	P3.7
J4.5	D4	RX10	P0.0
J4.6	D5	RX9	P3.5
J4.7	D6	RX8	P1.0
J4.8	D7	RX7	P2.7

2.4.5 Temperature Compensation Sensor

RX12 sensor on the shield board provides the ability to measure and compensate for environmental effects such as temperature on the liquid level sensors. Use of RX12 sensor for compensation is optional. RX12 is also brought out to the sensor connector (J5-9) although the supplied kit sensors do not use RX12. User can add an RX12 sensor connected to J5-9. In this case, resistor (R1) shown in [Figure 2-13](#) must be removed from the Shield board to disconnect the onboard sensor.

Figure 2-13. Sensor RX12



2.4.6 Integration Capacitors

Two integration capacitors are provided to support CapSense Mutual-Capacitance Scanning method. [Figure 2-14](#) shows the capacitors C_{intA} on J2-1 and C_{intB} on J2-3. The C_{int} capacitors on this shield can be used with Pioneer kits that do not natively support C_{int} capacitors.

Figure 2-14. Integration Capacitors

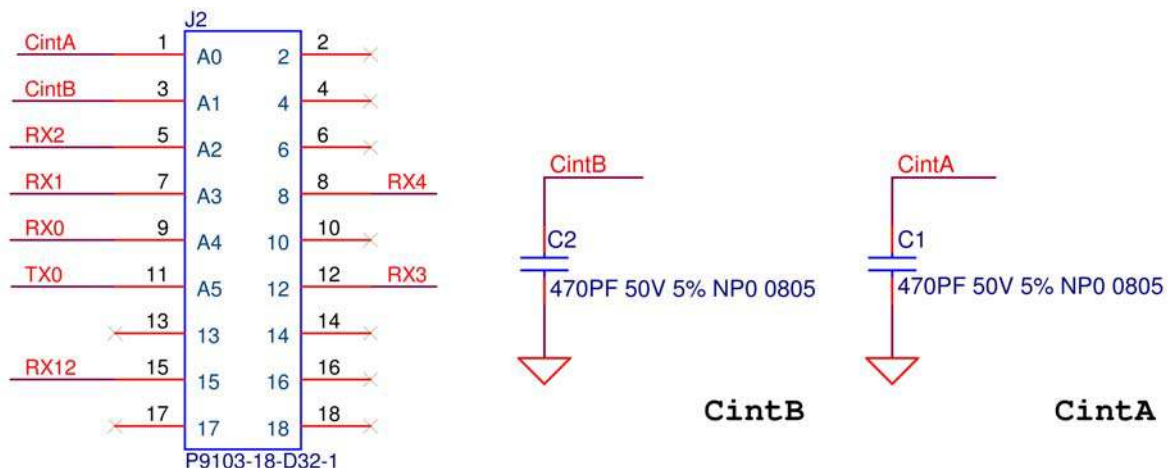

2.4.7 UART Connection

A dedicated connection is provided to connect the PSoC 4 I/O pins on J4-1 and J4-2 to the KitProg UART pins on J6-1 and J6-2. The J6 shield pins connect to the pioneer kit's KitProg J8 header, pin J8-9 (UART TX) and J8-10 (UART RX). The PSoC 4 device used on the CY8CKIT-040 kit does not provide a UART peripheral; therefore, the UART connection is not used with this kit. All other Pioneer kits provide an onboard UART connection; therefore, the J6 connection is not used with these kits. The UART connection shown in [Figure 2-15](#) allows the liquid level sensing firmware to implement a terminal interface for user interaction.

Figure 2-15. UART Connection

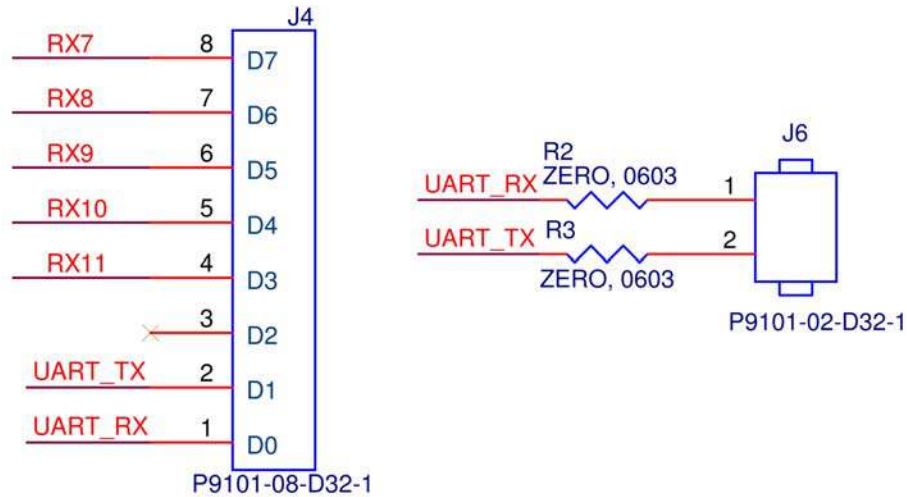

2.4.8 Liquid Container

The 32 oz Square PET plastic liquid container is provided for use with the flexible sensors. User supplied container can be used in its place if it is compatible with the sensor dimensions. You can also purchase the kit container (Item Number: 70348) from www.usplastic.com.

Hot water above 170 °F/80 °C can cause PET plastic to deform. Extremely hot water should be avoided as the liquid container provided in the CY8CKIT-022 kit is made of PET plastic.

3. Example Projects



[CY8CKIT-022](#) can be used with Cypress PSoC 4 Pioneer Kits to evaluate the liquid level sensing capabilities of CapSense in Cypress PSoC products. Code Example [CE202479](#) contains example projects that demonstrate the following features of CY8CKIT-022:

- Liquid level measurement using capacitive sensors
- Two sensor (2RX) project for use with the low cost 2RX flexible sensor
- 12 sensor (12RX) project for use with the increased accuracy 12RX flexible sensor

4. Design Support



Refer to the following documents and resources to start new liquid level sensing designs with PSoC 4 CapSense technology:

- [Getting Started with CapSense® Design Guide](#)
- [AN79953 - Getting Started with PSoC® 4](#)
- [PSoC 4 CapSense Design Guide](#)
- [AN202478 - PSoC 4 - Capacitive Liquid Level Sensing](#)
- [PSoC 4000, PSoC 4100, or PSoC 4200 Datasheet](#)
- [Online Technical Support](#)
- [Local Sales Support](#)

Cypress recommends that you create a Technical Support Case for getting schematics and Layouts of CapSense designs reviewed with Cypress.

Go to the webpage, www.cypress.com/techsupport, for creating a tech support case.

A. Appendix



A.1 Shield Schematic

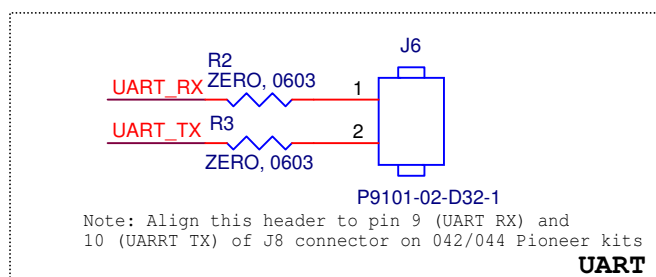
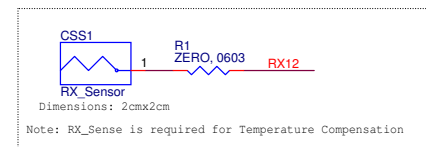
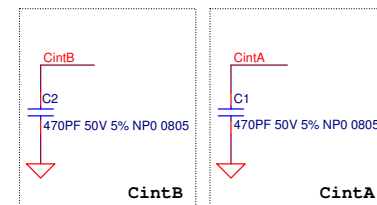
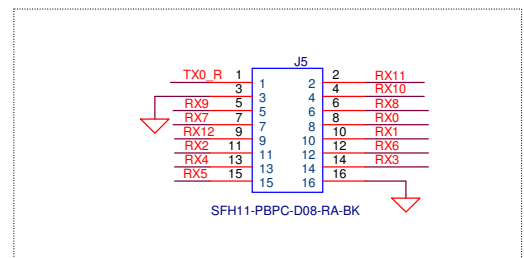
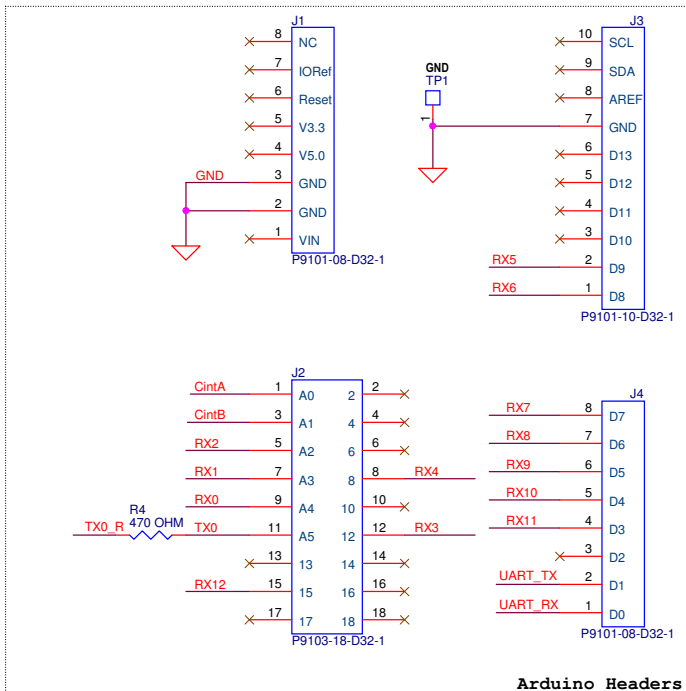

A.2 2RX Sensor Schematic

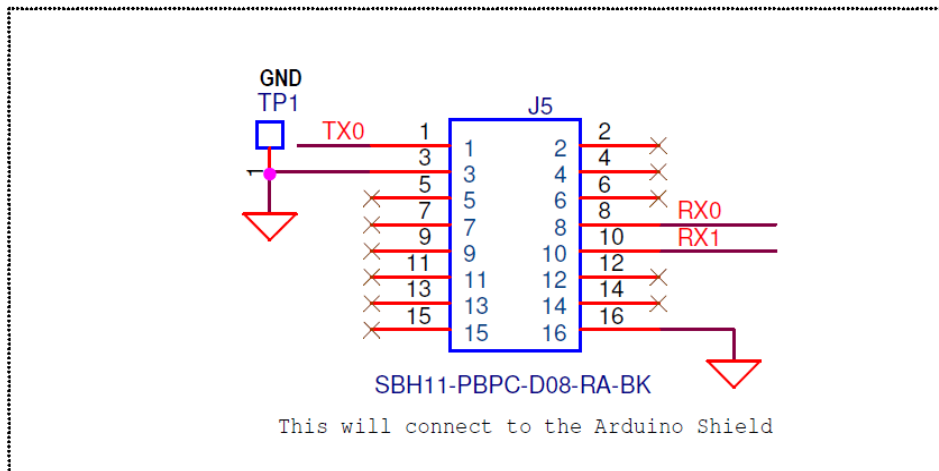
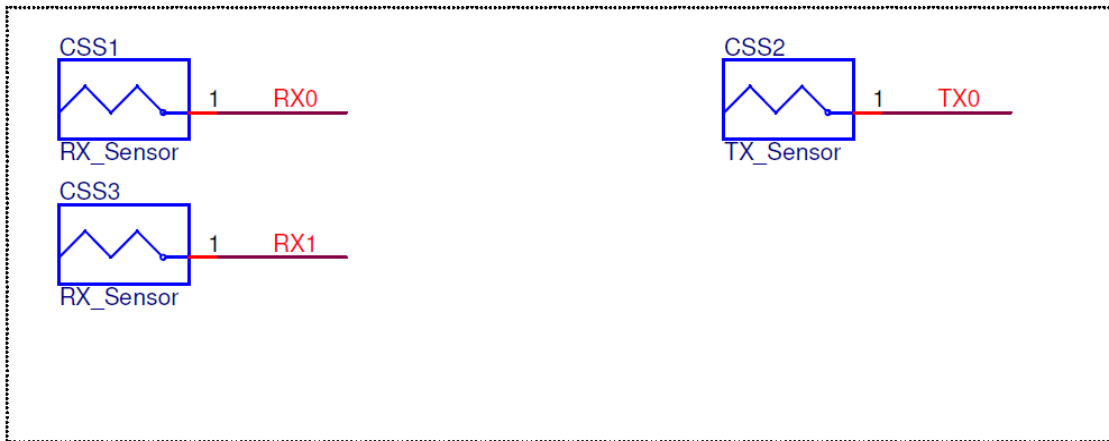

A.3 12RX Sensor Schematic

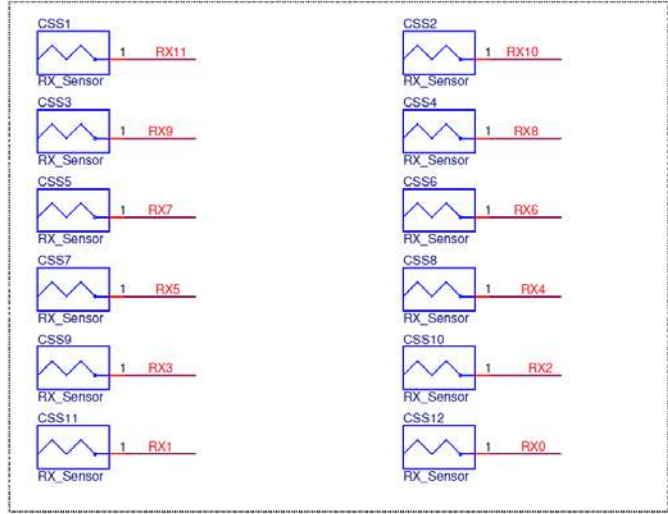
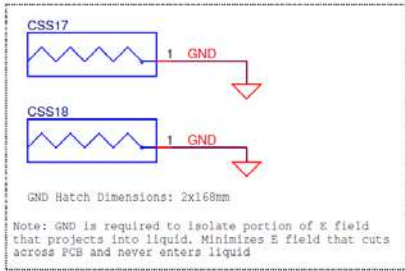
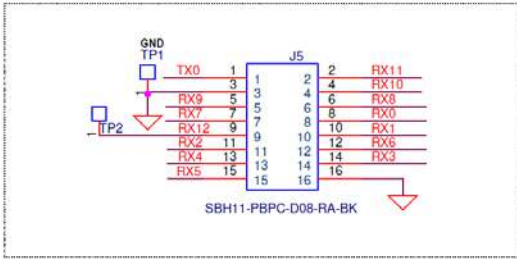

A.4 Shield Layout

Figure A-1. Top Layer

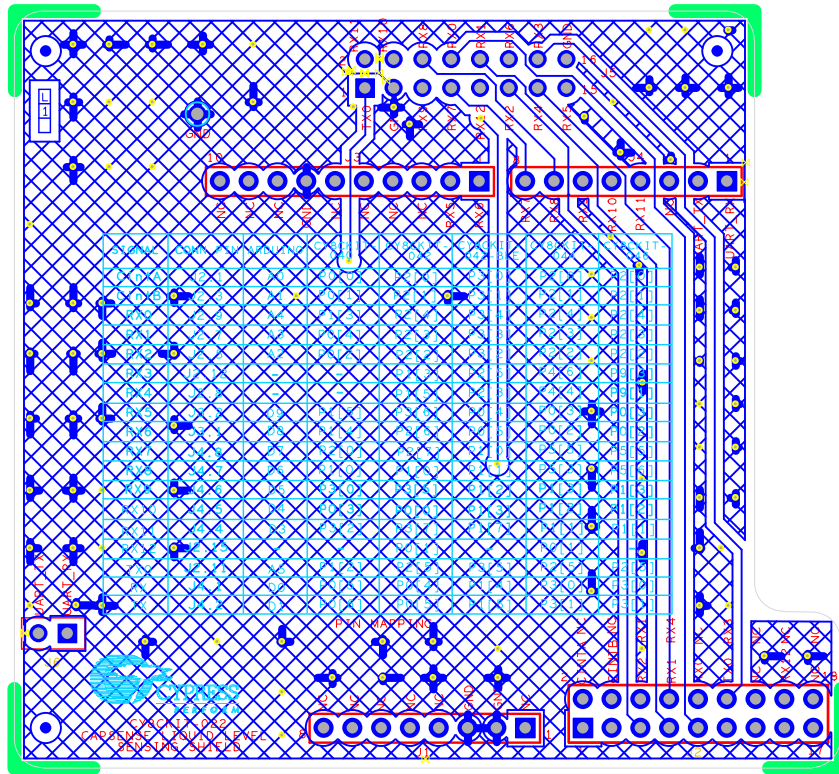
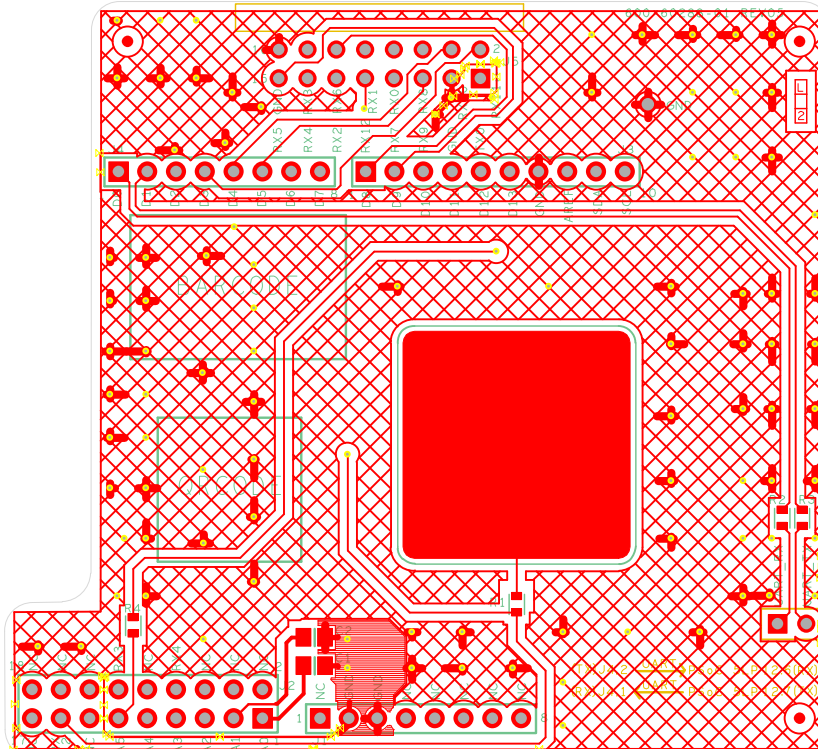

Figure A-2. Bottom Layer



A.5 2RX Sensor Layout

Figure A-3. Top Layer

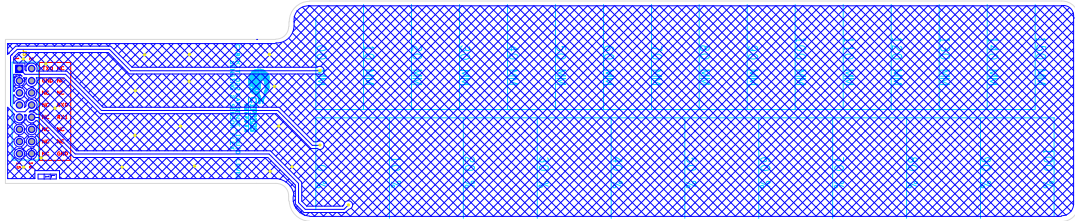
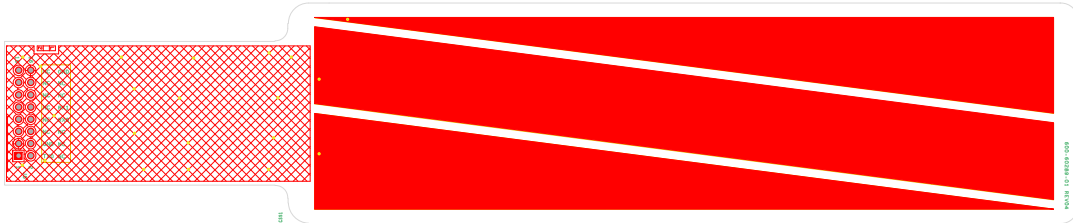

Figure A-4. Bottom Layer



A.7 Bill of Materials

Item	Qty	Reference	Description	Manufacturer	Mfr Part Number
1	1	PCB	PCB, FR4, 2 layer, High Tg, Mask - Red, Silk - White	Cypress Semiconductor	600-60288-01
2	2	C1, C2	CAP CER 470PF 50V 5% NP0 0805	Murata Electronics	GRM2165C1H471JA01D
3	2	J1, J4	HDR, 2.54mm PITCH, SINGLE ROW, 8POS, 13mm, MATING LENGTH	Protectron Electromech	P9101-08-D32-1
4	1	J2	HDR, 2.54mm PITCH, DUAL ROW, 18POS, 13mm, MATING LENGTH	Protectron Electromech	P9103-18-D32-1
5	1	J3	HDR, 2.54mm PITCH, SINGLE ROW, 10POS, 13mm, MATING LENGTH	Protectron Electromech	P9101-10-D32-1
6	1	J5	CONN 2.54MM 16POS GOLD R/A	Sullins Connector Solutions	SFH11-PBPC-D08-RA-BK
7	1	J6	HDR, 2.54mm PITCH, SINGLE ROW, 2POS, 13mm, MATING LENGTH	Protectron Electromech	P9101-02-D32-1
8	1	R1	RES SMD 0.0OHM JUMPER 1/10W 0603	Panasonic	ERJ-3GEY0R00V
9	2	R2, R3	RES SMD 0.0OHM JUMPER 1/10W 0603	Panasonic	ERJ-3GEY0R00V
10	1	R4	RES SMD 470 OHM 5% 1/10W 0603	Panasonic	ERJ-3GEYJ471V
11	1	TP1	TEST POINT PC MINI .040"D Black	Keystone Electronics	5001

Revision History



Document Revision History

Document Title: CY8CKIT-022 CapSense Liquid Level Sensing Shield Kit Guide			
Document Number: 002-09825			
Revision	ECN	Issue Date	Description of Change
**	5032502	12/03/2015	Initial version of kit guide.
*A	5751159	06/21/2017	Updated Cypress Logo and Copyright.
*B	6201449	06/11/2018	Updated Example Projects chapter on page 24 : Updated description. Added figure "Project Settings – Compiler Command Line Parameter". Updated to new template.
*C	6486278	02/15/2019	No technical updates. Completing Sunset Review.
*D	6792941	01/30/2020	Updated Introduction chapter on page 7 : Updated "Kit Contents" on page 7: Updated description. Added Figure 1-1 . Updated Example Projects chapter on page 24 : Updated description. Removed figure "Project Settings – Compiler Command Line Parameter". Updated to new template.