

Single-Stage PFC Controller

SG6980D

FEATURES OVERVIEW

- Innovative switching-charge multiplier divider
- Multi-vector control for improved PFC output transient response
- 1:2 synchronous switching with SYNC
- Average current mode control
- Remote on/off control
- Power-on sequence control
- Programmable PFC output-voltage control
- Cycle-by-cycle current limiting
- Over-voltage and under-voltage protections
- Brownout and open-loop protections
- Low start-up and operating current

APPLICATIONS

- Active-PFC switching power supplies
- TV and home appliances
- Computer and telecom

DESCRIPTION

The highly integrated SG6980D is designed for power supplies with boost power-factor-correction (PFC). It requires very few external components to achieve desirable operation and includes versatile protection / compensation. It is available in 16-pin DIP and SOP packages. The innovative switching-charge multiplier-divider enhances the PFC circuit's noise immunity. The proprietary multi-vector control scheme provides a fast transient response in a low-bandwidth PFC loop, in which the overshoot and undershoot of the PFC voltage are clamped. If the feedback loop is broken, SG6980D shuts off to prevent extra-high voltage on output. The PFC gate driver can be synchronized with external SYNC signal and the switching noise can be reduced. During start-up, the RDY (ready) is pulled low until the PFC output voltage reaches to the setting level. This signal can be used to control the second forward stage for proper power-on sequence. In addition, SG6980D provides complete protection functions, such as brownout protection and RI open/short.

TYPICAL APPLICATION

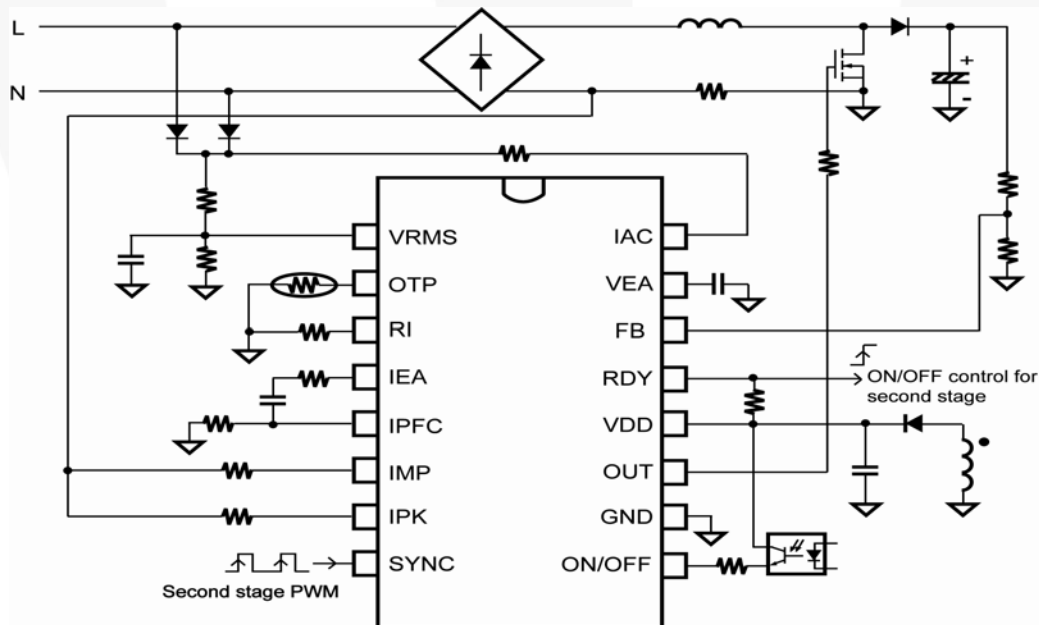

MARKING DIAGRAMS



T: D = DIP S=SOP
 P: Z = Lead Free
 XXXXXXXX: Wafer Lot
 Y: Year; WW: Week
 V: Assembly Location

PIN CONFIGURATION

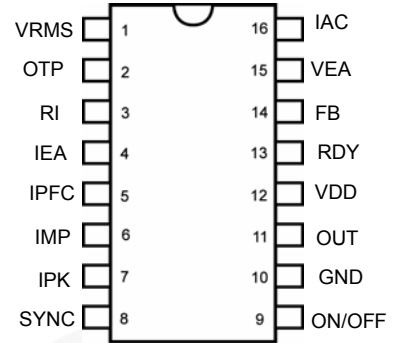

ORDERING INFORMATION

| Part Number | Pb-Free | Package |
|-------------------------|---------|------------|
| SG6980DDZ | | 16-Pin DIP |
| SG6980DSZ (Preliminary) | | 16-Pin SOP |

Single-Stage PFC Controller
SG6980D
PIN DESCRIPTIONS

| Name | Pin | Type | Function |
|--------|-----|--|--|
| VRMS | 1 | Line-Voltage Detection | Line voltage detection. The pin is used for PFC multiplier and brownout protection. For brownout protection, the controller will be disabled with a 195ms delay time when the VRMS voltage drops below 0.8V. There is a 200mV hysteresis for brownout protection. |
| OTP | 2 | Over-Temperature Protection | This pin supplies an over temperature protection signal. A constant current is output from this pin. If RI is equal to 24kΩ, then the magnitude of the constant current will be 50uA. An external NTC thermistor must be connected from this pin to ground. The impedance of the NTC thermistor decreases whenever the temperature increases. Once the voltage of the OTP pin drops below 1.2V, the SG6980D will be off, and will auto restart when the voltage is back to 1.4V. |
| RI | 3 | Oscillator Setting | The resistance of a resistor connected between RI and ground determines the switching frequency. A resistor with a resistance between 15kΩ and 40KΩ is recommended. The switching frequency is equal to $[1560 / RI]kHz$, where RI is kΩ. For example, if RI is equal to 24kΩ, the switching frequency is 65kHz. |
| IEA | 4 | Current Amplifier Output | This is the output of the PFC current amplifier. The signal from this pin is compared with an internal sawtooth and determines the pulse width for PFC gate drive. |
| IPFC | 5 | Inverting Input for PFC Current Amplifier | The inverting input of the PFC current amplifier. Proper external compensation circuits result in excellent input power factor via average-current-mode control. |
| IMP | 6 | Non-inverting Input for PFC Current Amplifier and Output of Multiplier | The non-inverting input of the PFC current amplifier and the output of multiplier. Proper external compensation circuits results in excellent input power factor via average current mode control. |
| IPK | 7 | Peak Current Limit | The peak current setting for PFC. |
| SYNC | 8 | Synchronous Signal | This pin receives the external switching signal. The PFC switching can be synchronized by SYNC with 1:2 ratio. |
| ON/OFF | 9 | Remote On/Off | Active high. The SG6980D is disabled whenever the voltage at this pin is lower than 1V or the pin is open. When SG6980D is disabled by ON/OFF, the IDD current is lower than 35μA. |
| GND | 10 | Ground | The ground. |
| OUT | 11 | Gate Drive | The totem pole output drive for the PFC MOSFET. This pin is internally clamped under 18V to protect the MOSFET. |
| VDD | 12 | Supply | The power supply pin. The threshold voltages for start-up and turn-off are 12.5V and 10V, respectively. The operating current is lower than 5mA. |
| RDY | 13 | Ready Signal Output | This pin outputs a ready signal to control the power on sequence. Once the SG6980D is turned on and the FB (PFC feedback input) voltage is higher than 2.7V, this pin locks to the high impedance. Disable the SG6980D resets this pin low. |
| FB | 14 | Feedback Input | The feedback input for PFC voltage loop. The inverting input of PFC error amp. This pin is connected to the PFC output through a divider network. |
| VEA | 15 | Error Amplifier Output | The error amplifier output for PFC voltage feedback loop. A compensation network (usually a capacitor) is connected between this pin and ground. A large capacitor value results in a narrow bandwidth and improves the power factor. |
| IAC | 16 | Input AC Current | This input is used to provide current reference for the multiplier. The suggested maximum I _{AC} is 350μA. |

Single-Stage PFC Controller

SG6980D

BLOCK DIAGRAM

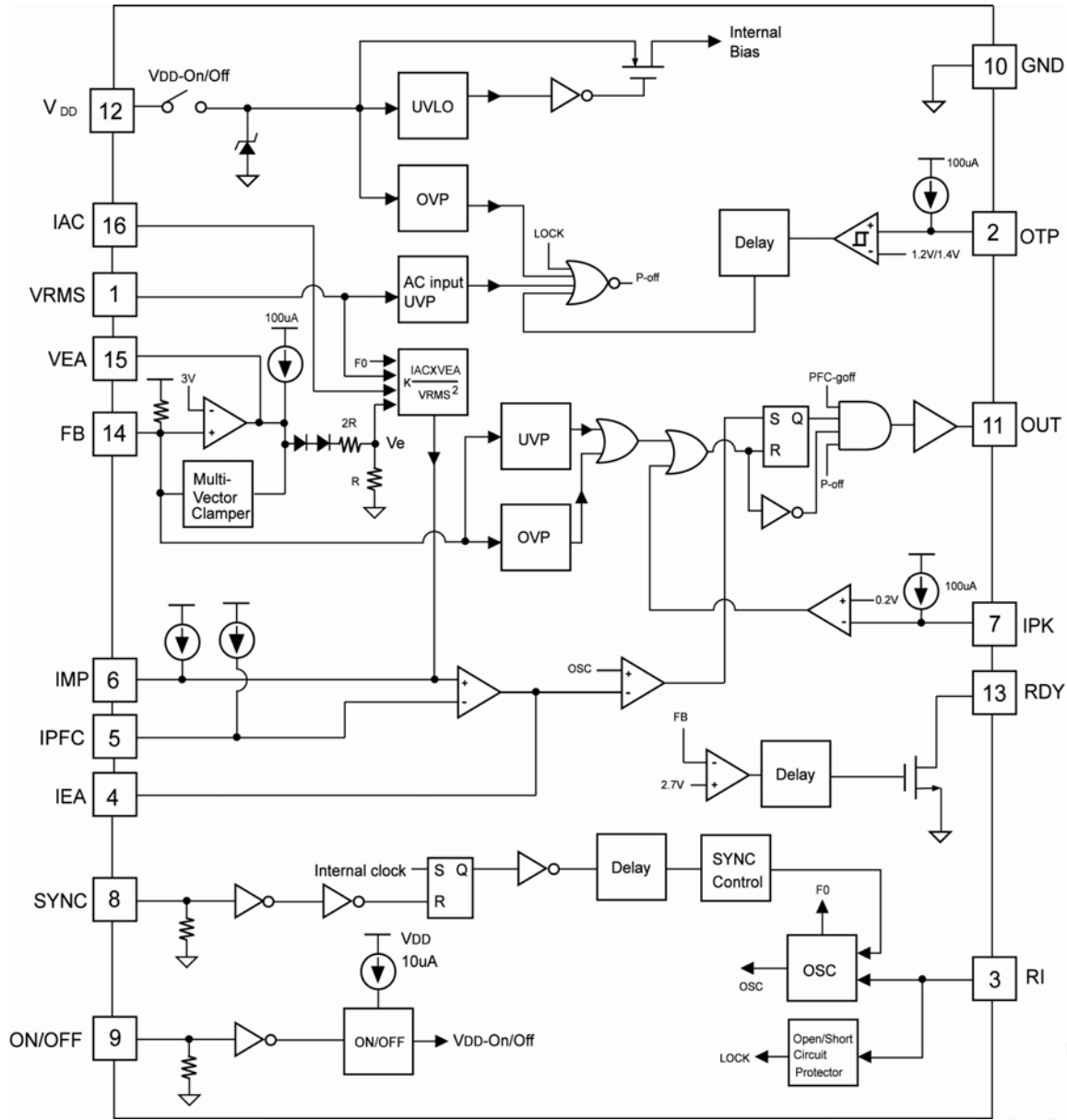

Single-Stage PFC Controller

SG6980D

ABSOLUTE MAXIMUM RATING

| Symbol | Parameter | Value | | Unit |
|----------------------|---|-------------|-------|------|
| V _{VDD} | DC Supply Voltage* | 25 | | V |
| I _{AC} | Input AC Current | 2 | | mA |
| V _{High} | OUT, SYNC, ON/OFF, RDY | -0.3 to 25V | | V |
| V _{Low} | Others | -0.3 to 7V | | V |
| P _D | Power Dissipation | DIP | 0.8 | W |
| | | SOP | 0.4 | |
| T _J | Operating Junction Temperature | +150 | | °C |
| T _A | Operating Ambient Temperature Range | -20~+125 | | |
| T _{STG} | Storage Temperature RDY | -55 to +150 | | °C |
| R _{θj-c} | Thermal Resistance (Junction-to-Case) | DIP | 36.70 | °C/W |
| | | SOP | 37.76 | |
| T _L | Lead Temperature (Wave Soldering or IR, 10 seconds) | 260 | | °C |
| V _{ESD,HBM} | ESD Capability, Human Body Model | 4 | | KV |
| V _{ESD,MM} | ESD Capability, Machine Model | 250 | | V |

*All voltage values, except differential voltages, are given with respect to the network ground terminal.

*Stress beyond those listed under “ABSOLUTE MAXIMUM RATING” may cause permanent damage to the device.

RECOMMENDED OPERATING TEMPERATURE :

| Symbol | Parameter | Value | Unit |
|----------------|-------------------------------|----------|------|
| T _A | Operating Ambient Temperature | -20 ~ 85 | °C |

*For proper operation

Single-Stage PFC Controller
SG6980D
ELECTRICAL CHARACTERISTICS
 $V_{DD}=15V$, $T_A=25^{\circ}C$ unless otherwise noted.

 V_{DD} Section

| Symbol | Parameter | Test Conditions | Min. | Typ. | Max. | Unit |
|----------------|---|--|------|------|------|---------|
| V_{DD-OP} | Continuously Operating Voltage | | | | 20 | V |
| I_{DD-OP} | Operating Current | $R_I = 24K\Omega$, $V_{DD} = 15V$; Gate Open | | 4 | 5 | mA |
| I_{IC-OFF} | Input Current | $V_{ON/OFF} < V_{ON}$, $V_{DD} = 25V$ | | 25 | 35 | μA |
| I_{DD-ST} | Start-up Current | $V_{DD} < V_{DD-ON} - 0.16V$ | | 10 | 20 | μA |
| V_{DD-ON} | Start Threshold Voltage | | 11.5 | 12.5 | 13.5 | V |
| V_{DD-OFF} | Minimum Operating Voltage | | 9 | 10 | 11 | V |
| V_{DD-OVP} | V_{DD} Over-Voltage Protection with Debounce Time | | 23.5 | 24.5 | 25.5 | V |
| $t_{D-VDDOVP}$ | Debounce Time of V_{DD} OVP Protection | | 10 | | 40 | μs |

Oscillator & Green-Mode Operation

| Symbol | Parameter | Test Conditions | Min. | Typ. | Max. | Unit |
|---------------|------------------------------------|-------------------|------|------|------|-----------|
| F_{OSC} | PWM Frequency | $R_I = 24K\Omega$ | 62 | 65 | 68 | KHz |
| R_I | Nominal R_I Value | | 15 | | 40 | $K\Omega$ |
| R_{I-OPEN} | Maximum R_I Value for Protection | | | 200 | | $K\Omega$ |
| $R_{I-SHORT}$ | Maximum R_I Value for Protection | | | 2 | | $K\Omega$ |

Single-Stage PFC Controller
SG6980D
VRMS for UVP and RDY

| Symbol | Parameter | Test Conditions | Min. | Typ. | Max. | Unit |
|-----------------|--|-----------------|------------------------|------------------------|------------------------|------|
| $V_{RMS-UVP-1}$ | RMS AC Voltage Under-voltage Threshold (with T_{UVP} Delay) | | 0.75 | 0.80 | 0.85 | V |
| $V_{RMS-UVP-2}$ | Recovery Level on VRMS for UVP Mode | | $V_{RMS-UVP-1} + 0.18$ | $V_{RMS-UVP-1} + 0.20$ | $V_{RMS-UVP-1} + 0.22$ | V |
| t_{UVP} | Under-Voltage Protection Propagation Delay Time (No Delay at Start-up) | | 150 | 195 | 240 | ms |

Voltage Error Amplifier

| Symbol | Parameter | Test Conditions | Min. | Typ. | Max. | Unit |
|-------------------|--|-----------------|-----------------------|-----------------------|-----------------------|------------|
| V_{REF} | Reference Voltage | | 2.95 | 3.00 | 3.05 | V |
| A_V | Open-Loop Gain | | | 60 | | dB |
| Z_o | Output Impedance | | | 110 | | K Ω |
| OVP_{FB} | PFC Over-Voltage Protection on FB | | $1.066 \cdot V_{REF}$ | $1.083 \cdot V_{REF}$ | $1.100 \cdot V_{REF}$ | V |
| ΔOVP_{FB} | PFC Feedback Voltage Protection Hysteresis | | 60 | 90 | 120 | mV |
| $t_{OVP-PFC}$ | Debounce Time of PFC OVP | | 40 | 70 | 120 | μ s |
| V_{FB-H} | Clamp-High Feedback Voltage | | $1.033 \cdot V_{REF}$ | $1.050 \cdot V_{REF}$ | $1.066 \cdot V_{REF}$ | V |
| G_{FB-H} | Clamp-High Gain | | | 500 | | μ A/mV |
| V_{FB-L} | Clamp-Low Feedback Voltage | | $0.916 \cdot V_{REF}$ | $0.950 \cdot V_{REF}$ | $0.966 \cdot V_{REF}$ | V |
| G_{FB-L} | Clamp-Low Gain | | | 6.5 | | μ A/mV |
| I_{FB-L} | Clamp-Low Maximum Current | | 1.5 | 2 | | mA |
| UVP_{FB} | PFC Feedback Under-Voltage Protection | | 0.35 | 0.40 | 0.45 | V |
| $t_{UVP-PFC}$ | Debounce Time of PFC Feedback UVP | | 40 | 70 | 120 | μ s |

Current Error Amplifier

| Symbol | Parameter | Test Conditions | Min. | Typ. | Max. | Unit |
|--------------------|----------------------------------|---|------|------|------|---------|
| V_{OFFSET} | Input Offset Voltage ((-) > (+)) | | | 8 | | mV |
| A_i | Open-Loop Gain | | | 60 | | dB |
| BW | Unit Gain Bandwidth | | | 1.5 | | MHz |
| CMRR | Common-Mode Rejection Ratio | $V_{CM} = 0 \sim 1.5V$ | | 70 | | dB |
| $V_{OUT-HIGH}$ | Output High Voltage | | 3.2 | | | V |
| $V_{OUT-LOW}$ | Output Low Voltage | | | | 0.2 | V |
| I_{MR1}, I_{MR2} | Reference Current source | $R_I = 24 K\Omega$ ($I_{MR} = 20 + I_{R1} \cdot 0.8$) | 50 | | 70 | μ A |
| I_L | Maximum Source Current | | 3 | | | mA |
| I_H | Maximum Sink Current | | | 0.25 | | mA |

Single-Stage PFC Controller
SG6980D
Peak Current Limit

| Symbol | Parameter | Test Conditions | Min. | Typ. | Max. | Unit |
|---------------|---|-------------------|------|------|------|---------|
| I_P | Constant Current Output | $R_I = 24K\Omega$ | 90 | 100 | 110 | μA |
| V_{PK} | Peak Current Limit Threshold Voltage Cycle-by-Cycle Limit ($V_{sense} < V_{pk}$) | $V_{RMS}=1.05V$ | 0.15 | 0.20 | 0.25 | V |
| | | $V_{RMS}=3V$ | 0.35 | 0.40 | 0.45 | V |
| t_{PD-PFC} | Propagation Delay | | | | 200 | ns |
| $t_{LEB-PFC}$ | Leading-Edge Blanking Time | | 250 | 330 | 430 | ns |

Multiplier

| Symbol | Parameter | Test Conditions | Min. | Typ. | Max. | Unit |
|--------------|--|---|------|------|------|---------|
| I_{AC} | Input AC Current | Linear RDY | 0 | | 360 | μA |
| I_{MO-MAX} | Maximum Multiplier Current Output; | $R_I=24 K\Omega$ | 230 | 250 | | μA |
| I_{MO-1} | Multiplier Current Output (Low-line, High-power) | $V_{RMS}=1.05V$; $I_{AC}=90\mu A$; $V_{EA}=7.5V$; $R_I=24K\Omega$ | 200 | 250 | 280 | μA |
| I_{MO-2} | Multiplier Current Output (High-line, High-power) | $V_{RMS}=3V$; $I_{AC}=264\mu A$; $V_{EA}=7.5V$; $R_I=2 K\Omega$ | 65 | 85 | | μA |
| V_{IMP} | Voltage of IMP Open | | 3.4 | 3.9 | 4.4 | V |

PFC Output Driver

| Symbol | Parameter | Test Conditions | Min. | Typ. | Max. | Unit |
|-------------|--------------------------------|--|------|------|------|------|
| V_Z | Output Voltage Maximum (clamp) | $V_{DD}=20V$ | | 15 | 18 | V |
| V_{OL} | Output Voltage Low | $V_{DD} = 15V$; $I_O = 100mA$ | | | 1.5 | V |
| V_{OH} | Output Voltage High | $V_{DD} = 13V$; $I_O = 100mA$ | 8 | | | V |
| t_R | Rising Time | $V_{DD} = 15V$; $C_L = 5nF$; $OUT = 2V$ to $9V$ | 30 | 70 | 120 | ns |
| t_F | Falling Time | $V_{DD} = 15V$; $C_L = 5nF$; $OUT = 9V$ to $2V$ | 30 | 50 | 100 | ns |
| DCY_{MAX} | Maximum Duty Cycle | | 93 | | 98 | % |

RDY Section

| Symbol | Parameter | Test Conditions | Min. | Typ. | Max. | Unit |
|---------------------------|--|------------------|------|------|------|------|
| $FB_{RDY-high}$ | FB Voltage, RDY High Impedance | | | 2.7 | | V |
| $I_{FB-RDY-high}$ | Input Leakage Current, RDY High Impedance | $FB=2.5V$ | | | 500 | nA |
| V_{OL} | Output Voltage Low, RDY Failed | $I_{SINK} = 1mA$ | | | 0.5 | V |
| $t_{RDY-delay time}$ | Interval Between $FB > 2.7V$ and RDY High Impedance | | | 4 | 6 | ms |
| $t_{RDY-UVP_delay time}$ | Delay Time Between Gate off and RDY Pull Low when UVP Occurs | | 10 | | 16 | ms |

OTP Section

| Symbol | Parameter | Test Conditions | Min. | Typ. | Max. | Unit |
|---------------|------------------------|-------------------|------|------|------|---------|
| I_{OTP} | OTP Pin Output Current | $R_I = 24K\Omega$ | 90 | 100 | 110 | μA |
| $V_{OTP-OFF}$ | OTP Threshold Voltage | | 1.15 | 1.20 | 1.25 | V |
| V_{OTP-ON} | Recovery Level on OTP | | 1.35 | 1.40 | 1.45 | V |
| T_{OTP} | OTP Debounce Time | | 10 | | 40 | μs |

Single-Stage PFC Controller

SG6980D

SYNC Section

| Symbol | Parameter | Test Conditions | Min. | Typ. | Max. | Unit |
|--------------------------|---|-----------------|------------------------------|------|------|------|
| V _{SYNC-HIGH} | Synchronizing Signal High Threshold | | 3.5 | | | V |
| V _{SYNC-LOW} | Synchronizing Signal Low Threshold | | | | 0.9 | V |
| F _{Min} | Minimum Synchronizing Frequency | RI=24KΩ | 2 • (F _{osc} -12.5) | | | KHz |
| F _{Max} | Maximum Synchronizing Frequency | | | | 250 | KHz |
| t _{MIN_PULSE_W} | Minimum Synchronizing Pulse Width | RI = 24KΩ | 100 | 200 | 500 | ns |
| t _{MAX_PULSE_W} | Maximum Synchronizing Pulse Width | RI = 24KΩ | | 15.8 | | μs |
| t _{D-65KHZ} | Delay Time Between SYNC and OUT, Switching Frequency = 65KHz | RI=24KΩ | 1 | | 3 | μs |
| t _{D-50KHZ} | Delay Time Between SYNC and OUT, Switching Frequency = 50KHz | RI=31.2KΩ | 1 | | 3 | μs |

ON/OFF Section

| Symbol | Parameter | Test Conditions | Min. | Typ. | Max. | Unit |
|---------------------|---------------------------------|-----------------|------|------|------|------|
| R _{on/off} | Impedance of ON/OFF Pin | | 18 | 27 | 50 | KΩ |
| V _{ON} | High Threshold of Enable Signal | | 3 | | | V |
| V _{OFF} | Low Threshold of Disable Signal | | | | 1 | V |

Single-Stage PFC Controller

SG6980D

TYPICAL CHARACTERISTICS

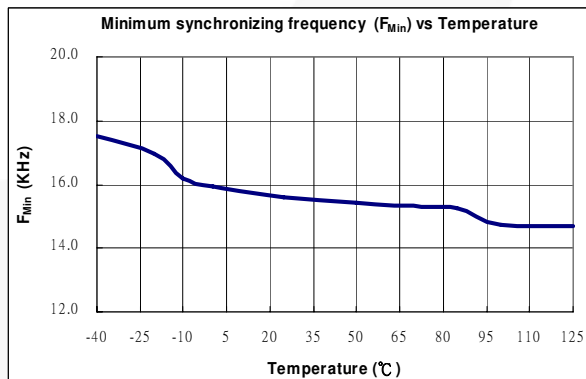
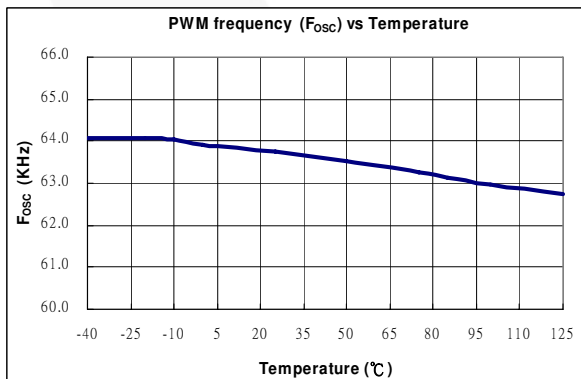
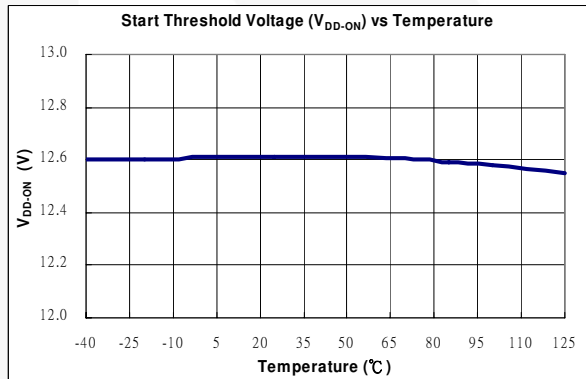
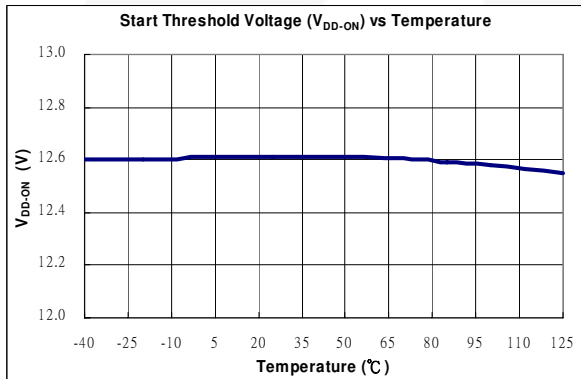
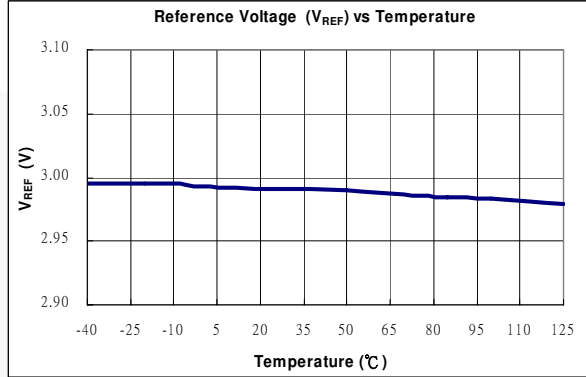
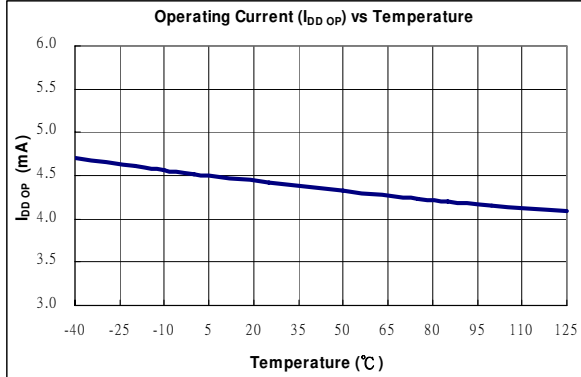

Single-Stage PFC Controller

SG6980D

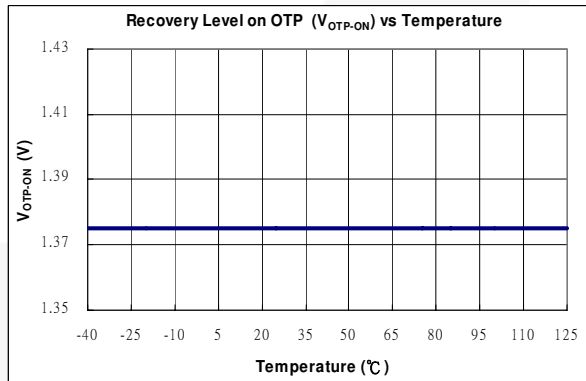
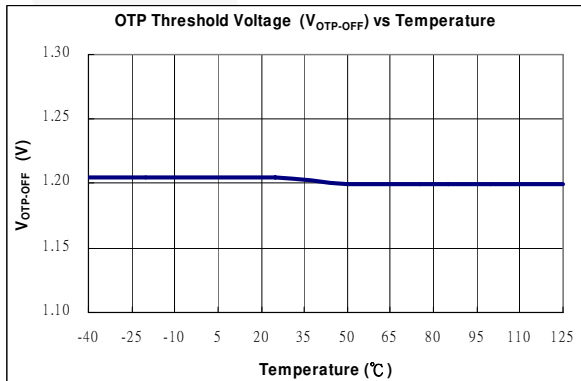
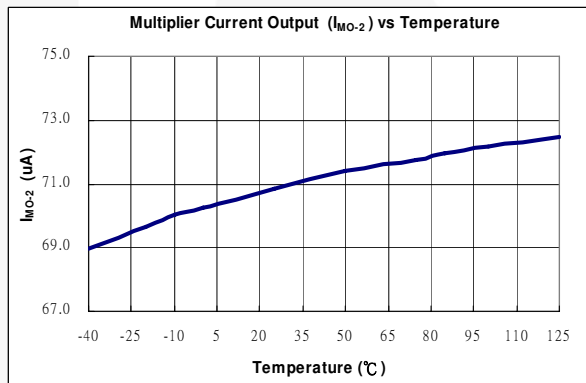
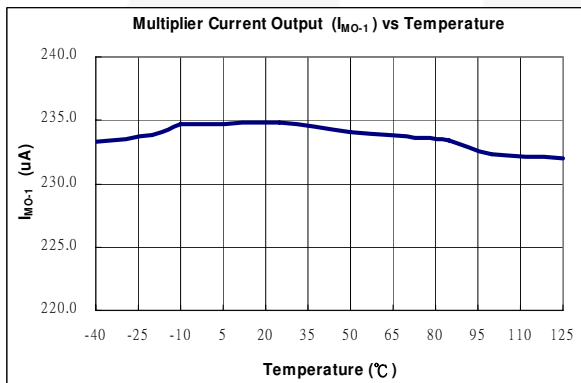
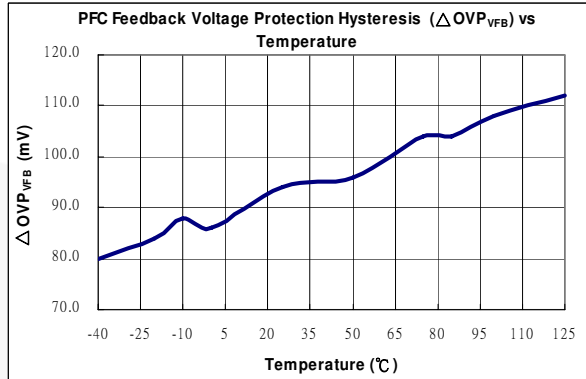
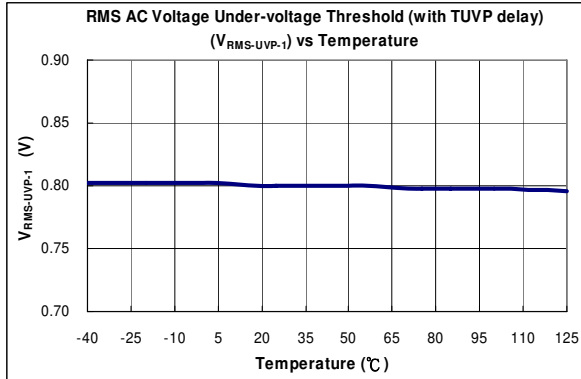

Single-Stage PFC Controller

SG6980D

OPERATION DESCRIPTION

The highly integrated SG6980D is designed for a power supply with boost PFC. It requires very few external components to achieve high performance and versatile protections / compensation.

The PFC function is implemented by average current mode control. The patented switching-charge multiplier-divider provides a high-degree of noise immunity for the PFC circuit. This also enables the PFC circuit to operate over a much wider region. The proprietary multi-vector output voltage control scheme provides a fast transient response in a low-bandwidth PFC loop, in which the overshoot and undershoot of the PFC voltage are clamped. If the feedback loop is broken, the SG6980D shuts off the PFC to prevent extra-high voltage on output. Programmable two-level high/low line compensation optimizes THD performance.

In addition, SG6980D provides complete protection functions, such as brownout protection and RI open/short.

Switching Frequency and Current Sources

The switching frequency of SG6980D can be programmed by the resistor R_I connected between RI pin and GND. The relationship is:

$$f_{PWM} = \frac{1560}{R_I \text{ (k}\Omega\text{)}} \text{ (kHz)} \text{ ----- (1)}$$

For example, a 24kΩ resistor R_I results in a 65kHz switching frequency. Accordingly, constant current I_T flows through R_I:

$$I_T = \frac{1.2V}{R_I \text{ (k}\Omega\text{)}} \text{ (mA)} \text{ ----- (2)}$$

I_T is used to generate internal current reference.

If there is a SYNC signal input, the switching frequency is defined by the SYNC signal. The SYNC frequency must be larger than the programmed switching frequency, less 6KHz.

Line Voltage Detection (V_{RMS})

Figure 1 shows a resistive divider with low-pass filtering for line-voltage detection on VRMS pin. The V_{RMS} voltage is used for the PFC multiplier, brownout protection, and RDY control.

For brownout protection, the SG6980D is disabled with a 195ms delay time if the voltage V_{RMS} drops below 0.8V.

For PFC multiplier and RDY control, please refer to below sections for more detail.

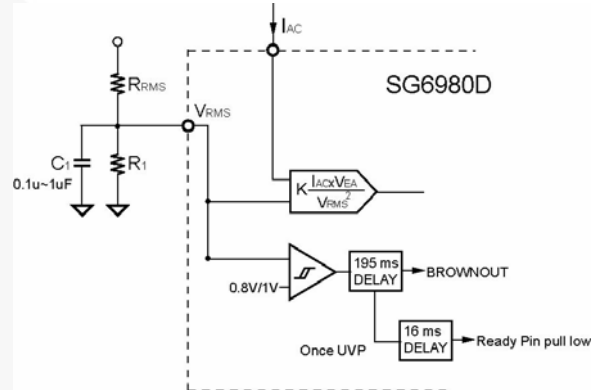

FIG.1

PFC Output Voltage Control

For a universal input (90VAC ~ 264VAC) power supply applying active boost PFC and forward as a second stage, the output voltage of PFC is usually designed around 400V.

$$V_O = \frac{R_A + R_B}{R_B} \times 3V \text{ ---- (3)}$$

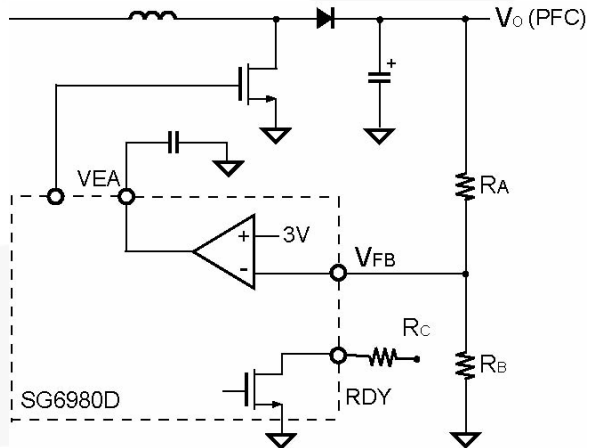

FIG.2 Output Voltage Setting

Single-Stage PFC Controller

SG6980D

ON/OFF

For ON/OFF control, the SG6980D is disabled immediately if the voltage at this pin is below 1V. Usually, the pin opens when turn off can have the best power saving. The operating current during turn off is less than 35µA.

SYNC Signal Section

The SG6980D can synchronize half frequency of the SYNC signal and the synchronize signal provided by second stage. This reduces switching noise and the ripple on the output voltage. Figure 3 shows the relationship between the OUT and SYNC signals.

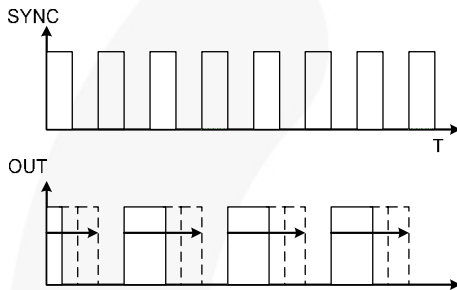

FIG.3 Synchronized Interleaving-Switching

RDY Signal Section

SG6980D provides a RDY pin to inform the next stage and other applications. RDY signal is high impedance when the FB voltage goes up to 2.7V and the delay around 5ms. Use the pin to turn on the second stage PWM when the bulk capacitor voltage is high enough. The RDY pin (open-drain structure) is used for the next-stage-ready signal.

PFC Operation

The purpose of a boost active power factor corrector (PFC) is to shape the input current of a power supply. The input current waveform and phase follow that of the input voltage. Using SG6980D, average-current-mode control is utilized for continuous current mode for the PFC booster. With the innovative multi-vector control for voltage loop and switching-charge multiplier/divider for current reference, excellent input power factor is achieved with good noise immunity and transient response. Figure 4 shows the total control loop for the average-current-mode control circuit of SG6980D.

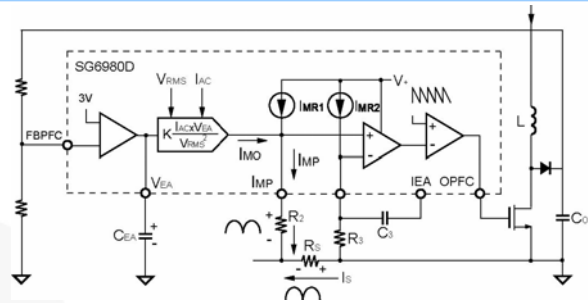

FIG.4 Multiplier and Control Loop of PFC Stage

The current source output from the switching-charge multiplier/divider can be expressed as:

$$I_{MO} = K \times \frac{I_{AC} \times V_{EA}}{V_{RMS}^2} (\mu A) \dots\dots\dots (4)$$

I_{IMP} , the current output from IMP pin, is the summation of I_{MO} and I_{MR1} . I_{MR1} and I_{MR2} are identical fixed current sources. R_2 and R_3 are also identical. They are used to pull high the operating point of the IMP and ICS pins if the voltage across R_S goes negative with respect to ground.

Through the differential amplification of the signal across R_S , better noise immunity is achieved. The output of IEA is compared with an internal sawtooth and the pulse width for PFC is determined. Through the average current-mode control loop, the input current I_S is proportional to I_{MO} .

$$I_{MO} \times R_2 = I_S \times R_S \dots\dots\dots (5)$$

According to Equation 5, the minimum value of R_2 and maximum of R_S can be determined because I_{MO} should not exceed the specified maximum value.

There are different concerns in determining the value of the sense resistor R_S . The value of R_S should be small enough to reduce power consumption, but large enough to maintain the resolution. A current transformer (CT) may be used to improve the efficiency of high-power converters.

To achieve a good power factor, the voltage for V_{RMS} and V_{EA} should be kept as DC as possible according to Equation 4. Good RC filtering for V_{RMS} and narrow bandwidth (lower than the line frequency) for voltage loop are suggested for better input current shaping. The transconductance error amplifier has output impedance R_O and a capacitor C_{EA} ($1\mu F \sim 10\mu F$) connected to ground (as shown in FIG. 4). This establishes a dominant pole f_l (Equation 6) for the voltage loop.

Single-Stage PFC Controller

SG6980D

$$f_1 = \frac{1}{2\pi \times R_0 \times C_{EA}} \text{----- (6)}$$

The average total input power can be expressed as:

$$\begin{aligned} P_{in} &= V_{in(rms)} \times I_{in(rms)} \\ &\propto V_{RMS} \times I_{MO} \\ &\propto V_{RMS} \times \frac{I_{AC} \times V_{EA}}{V_{RMS}^2} \\ &\propto V_{RMS} \times \frac{V_{in}}{R_{AC}} \times V_{EA} \\ &\propto V_{RMS} \times \frac{V_{in}}{V_{RMS}^2} \propto V_{EA} \end{aligned} \text{----- (7)}$$

From Equation 7, V_{EA} , the output of the voltage error amplifier, controls the total input power and the power delivered to the load.

Multi-Vector Error Amplifier

The voltage-loop error amplifier is transconductance, which has high output impedance (> 90kΩ). A capacitor C_{EA} (1μF ~ 10μF) connected from V_{EA} to ground provides a dominant pole for the voltage loop. Although the PFC stage has a low bandwidth voltage loop for better input power factor, the innovative multi-vector error amplifier provides a fast transient response to clamp the overshoot and undershoot of the PFC output voltage. Figure 5 shows the voltage loop with multi-vector for fast transient error amplifier. When the variation of the feedback voltage exceeds ± 5% of the reference voltage, the transconductance error amplifier adjusts its output impedance to increase the loop response. If the feedback resistance is opened, SG6980D shuts off immediately to prevent extra-high voltage on the output capacitor.

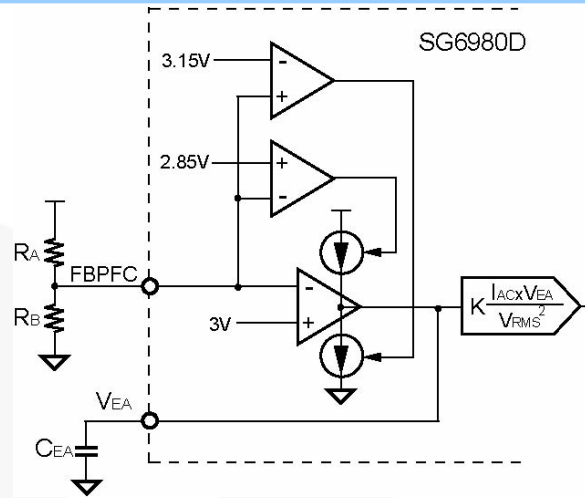

FIG. 5 Voltage Error Amplifier with Multi-Vector

Cycle-by-Cycle Current Limiting

SG6980D provides cycle-by-cycle current limiting for PFC stages. Figure 6 shows the peak current limit for the PFC stage. The PFC gate drive is terminated once the voltage on I_{PK} pin goes below V_{PK} .

The voltage of V_{RMS} determines the voltage of V_{PK} . The relationship between V_{PK} and V_{RMS} is shown in Figure 6.

The amplitude of the constant current I_P is determined by the internal current reference I_T , according to the following equation:

$$I_P = 2 \times I_T = 2 \times \frac{1.2V}{R_1} \text{----- (8)}$$

Therefore the peak current of the I_S is given by:

$$I_{S_peak} = \frac{(I_P \times R_P) - V_{pk}}{R_S} \text{----- (9)}$$

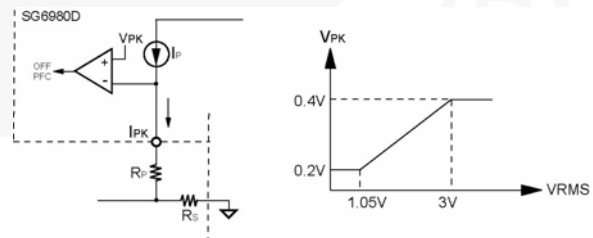

FIG.6 Current Limit

Single-Stage PFC Controller

SG6980D

Gate Drivers

SG6980D output stages are fast totem-pole gate drivers. The output driver is clamped by an internal 18V Zener diode to protect the power MOSFET.

Over-Temperature Protection

SG6980D provides an OTP pin for over-temperature protection. A constant current is output from this pin. If RI is equal to 24kΩ, the magnitude of the constant current is 50μA. An external NTC thermistor must be connected from this pin to ground. When the OTP voltage drops below 1.2V, SG6980D shuts down. SG6980D auto restarts when the OTP voltage is higher than 1.4V.

Protections & Built-in Latch Circuit

The SG6980D provides full protection functions to prevent the power supply and the load from being damaged. The protection features include:

PFC Feedback Over-Voltage Protection. When the PFC feedback voltage exceeds the over-voltage threshold, the SG6980D inhibits the PFC switching signal. This protection prevents the PFC power converter from operating abnormally while the FB pin is open.

PFC Feedback Under-Voltage Protection. The SG6980D stops the PFC switching signal whenever the PFC feedback voltage drops below the under-voltage threshold. This protection feature is designed to prevent the PFC power converter from experiencing abnormal conditions while the FB pin is shorted to ground.

VDD Over-Voltage Protection. The built-in clamping circuit clamps V_{DD} whenever the V_{DD} voltage exceeds the over-voltage threshold.

RI Pin Open / Short Protection. The RI pin is used to set the switching frequency and internal current reference. If the RI pin is shorted or open, SG6980D turns off.

PCB Layout

The SG6980D has a single ground pin. High sink currents in the output cannot be returned separately. Good high-frequency or RF layout practices should be followed. Avoid long PCB traces and component leads. Locate decoupling capacitors near the SG6980D. A resistor of 5 ~ 20Ω is recommended for connecting in series from the output to the gate of the MOSFET.

Isolating the interference between the PFC and PWM stages is also important. Figure 7 shows an example of the PCB layout. The *ground trace 1* is connected from the ground pin of SG6980D to the decoupling capacitor, which should be low impedance and as short as possible. The *ground trace 2* provides a signal ground. It should be connected directly to the decoupling capacitor C_{DD} and/or to the ground pin of the SG6980D. The *ground trace 3* is independently tied from the decoupling capacitor to the PFC output capacitor C_O. The ground in the output capacitor C_O is the major ground reference for power switching. To provide a good ground reference and reduce the switching noise of both the PFC and PWM stages, the *ground traces 6 and 7* should be located very near and be low impedance.

The ICS pin is connected directly to R_S through R₃ to improve noise immunity. (Beware that it may incorrectly be connected to the ground trace 2). The IMP and IPK pins should be connected directly via the resistors R₂ and R_P to another terminal of R_S.

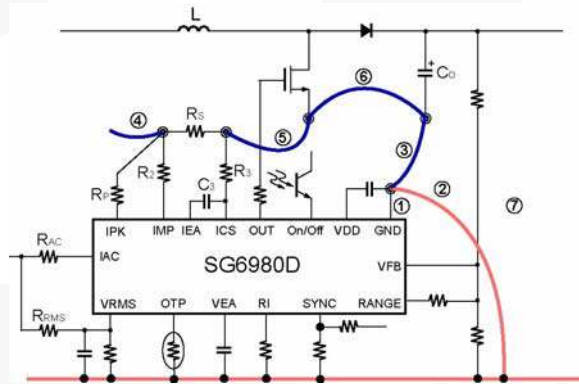
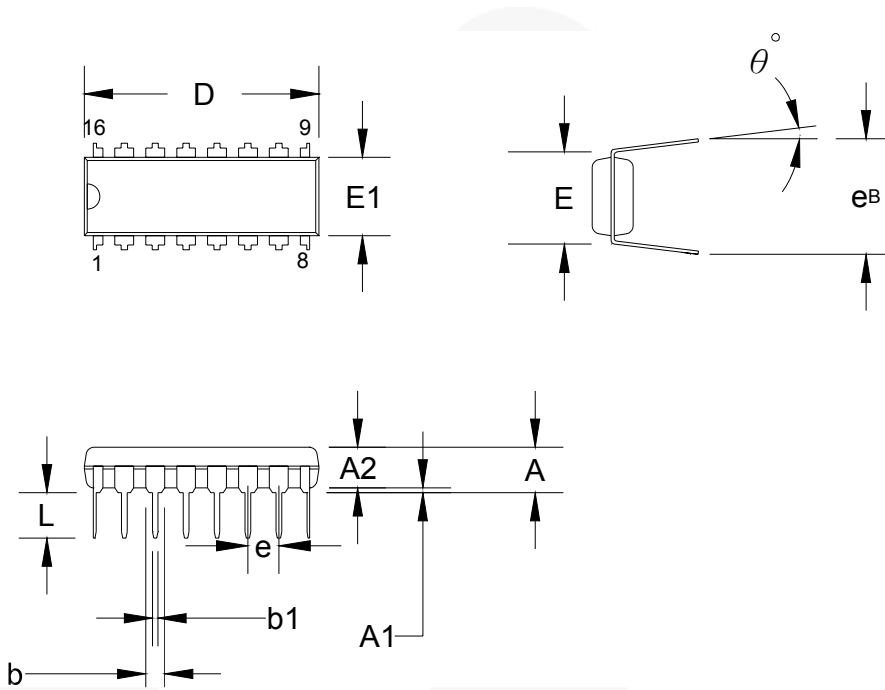

FIG. 7 PCB Layout

PACKAGE INFORMATION

16 PINS – PLASTIC DIP (D)



Dimensions:

| Symbol | Millimeter | | | Inch | | |
|----------------|------------|--------|--------|-------|-------|-------|
| | Min. | Typ. | Max. | Min. | Typ. | Max. |
| A | | | 5.334 | | | 0.210 |
| A1 | 0.381 | | | 0.015 | | |
| A2 | 3.175 | 3.302 | 3.429 | 0.125 | 0.130 | 0.135 |
| b | | 1.524 | | | 0.060 | |
| b1 | | 0.457 | | | 0.018 | |
| D | 18.669 | 19.177 | 19.685 | 0.735 | 0.755 | 0.775 |
| E | | 7.620 | | | 0.300 | |
| E1 | 6.121 | 6.299 | 6.477 | 0.241 | 0.248 | 0.255 |
| e | | 2.540 | | | 0.100 | |
| L | 2.921 | 3.302 | 3.810 | 0.115 | 0.130 | 0.150 |
| e^B | 8.509 | 9.017 | 9.525 | 0.335 | 0.355 | 0.375 |
| θ° | 0° | 7° | 15° | 0° | 7° | 15° |

16 PINS – PLASTIC SOP (S)

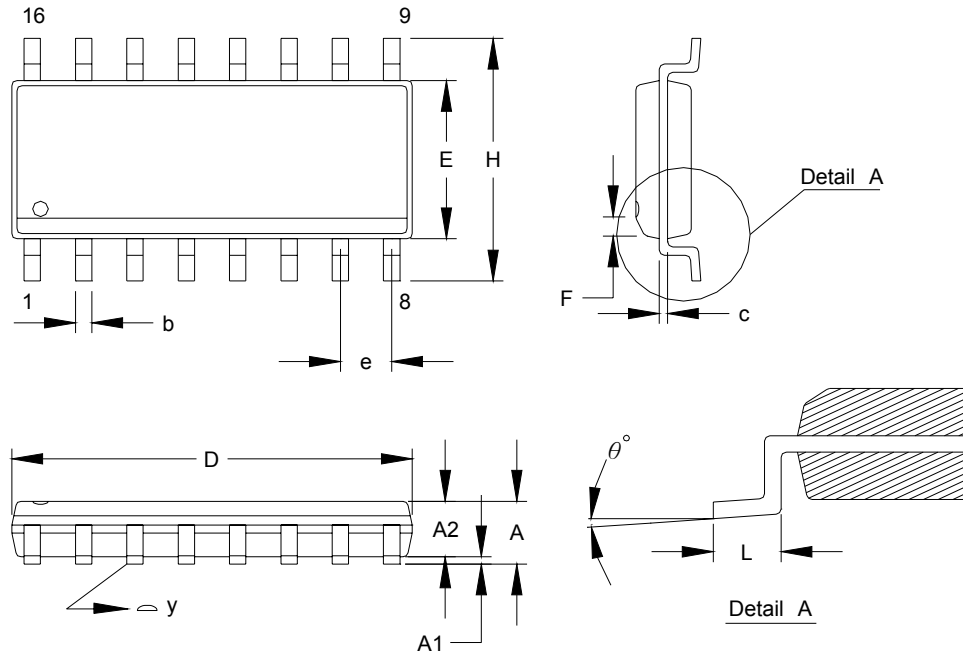

Dimension:

| Symbol | Millimeter | | | Inch | | |
|----------------|------------|-----------|--------|-------|-----------|-------|
| | Min. | Typ. | Max. | Min. | Typ. | Max. |
| A | 1.346 | | 1.753 | 0.053 | | 0.069 |
| A1 | 0.101 | | 0.254 | 0.004 | | 0.010 |
| A2 | 1.244 | | 1.499 | 0.049 | | 0.059 |
| b | | 0.406 | | | 0.016 | |
| c | | 0.203 | | | 0.008 | |
| D | 9.804 | | 10.008 | 0.386 | | 0.394 |
| E | 3.810 | | 3.988 | 0.150 | | 0.157 |
| e | | 1.270 | | | 0.050 | |
| H | 5.791 | | 6.198 | 0.228 | | 0.244 |
| L | 0.406 | | 1.270 | 0.016 | | 0.050 |
| F | | 0.381X45° | | | 0.015X45° | |
| y | | | 0.101 | | | 0.004 |
| θ° | 0° | | 8° | 0° | | 8° |

Single-Stage PFC Controller

SG6980D



TRADEMARKS

The following are registered and unregistered trademarks and service marks Fairchild Semiconductor owns or is authorized to use and is not intended to be an exhaustive list of all such trademarks.

- | | | | |
|--------------------------------------|--|--|----------------------------------|
| ACE [®] | Green FPS [™] | Power247 [®] | SuperSOT [™] -8 |
| Build it Now [™] | Green FPS [™] e-Series [™] | POWEREDGE [®] | SyncFET [™] |
| CorePLUS [™] | GTO [™] | Power-SPM [™] | The Power Franchise [®] |
| CROSSVOLT [™] | i-Lo [™] | PowerTrench [®] | the power franchise |
| CTL [™] | IntelliMAX [™] | Programmable Active Droop [™] | TinyBoost [™] |
| Current Transfer Logic [™] | ISOPLANAR [™] | QFET [®] | TinyBuck [™] |
| EcoSPARK [®] | MegaBuck [™] | QS [™] | TinyLogic [®] |
| f [®] | MICROCOUPLER [™] | QT Optoelectronics [™] | TINYOPTO [™] |
| Fairchild [®] | MicroFET [™] | Quiet Series [™] | TinyPower [™] |
| Fairchild Semiconductor [®] | MicroPak [™] | RapidConfigure [™] | TinyPWM [™] |
| FACT Quiet Series [™] | MillerDrive [™] | SMART START [™] | TinyWire [™] |
| FACT [®] | Motion-SPM [™] | SPM [®] | μSerDes [™] |
| FAST [®] | OPTOLOGIC [®] | STEALTH [™] | UHC [®] |
| FastvCore [™] | OPTOPLANAR [®] | SuperFET [™] | UniFET [™] |
| FPS [™] |  [®] | SuperSOT [™] -3 | VCX [™] |
| FRFET [®] | PDP-SPM [™] | SuperSOT [™] -6 | |
| Global Power Resource SM | Power220 [®] | | |

DISCLAIMER

FAIRCHILD SEMICONDUCTOR RESERVES THE RIGHT TO MAKE CHANGES WITHOUT FURTHER NOTICE TO ANY PRODUCTS HEREIN TO IMPROVE RELIABILITY, FUNCTION, OR DESIGN. FAIRCHILD DOES NOT ASSUME ANY LIABILITY ARISING OUT OF THE APPLICATION OR USE OF ANY PRODUCT OR CIRCUIT DESCRIBED HEREIN; NEITHER DOES IT CONVEY ANY LICENSE UNDER ITS PATENT RIGHTS, NOR THE RIGHTS OF OTHERS. THESE SPECIFICATIONS DO NOT EXPAND THE TERMS OF FAIRCHILD'S WORLDWIDE TERMS AND CONDITIONS, SPECIFICALLY THE WARRANTY THEREIN, WHICH COVERS THESE PRODUCTS.

LIFE SUPPORT POLICY

FAIRCHILD'S PRODUCTS ARE NOT AUTHORIZED FOR USE AS CRITICAL COMPONENTS IN LIFE SUPPORT DEVICES OR SYSTEMS WITHOUT THE EXPRESS WRITTEN APPROVAL OF FAIRCHILD SEMICONDUCTOR CORPORATION.

As used herein:

1. Life support devices or systems are devices or systems which, (a) are intended for surgical implant into the body or (b) support or sustain life, and (c) whose failure to perform when properly used in accordance with instructions for use provided in the labeling, can be reasonably expected to result in a significant injury of the user.
2. A critical component in any component of a life support, device, or system whose failure to perform can be reasonably expected to cause the failure of the life support device or system, or to affect its safety or effectiveness.

PRODUCT STATUS DEFINITIONS

Definition of Terms

| Datasheet Identification | Product Status | Definition |
|--------------------------|------------------------|--|
| Advance Information | Formative or In Design | This datasheet contains the design specifications for product development. Specifications may change in any manner without notice. |
| Preliminary | First Production | This datasheet contains preliminary data; supplementary data will be published at a later date. Fairchild Semiconductor reserves the right to make changes at any time without notice to improve design. |
| No Identification Needed | Full Production | This datasheet contains final specifications. Fairchild Semiconductor reserves the right to make changes at any time without notice to improve design. |
| Obsolete | Not In Production | This datasheet contains specifications on a product that has been discontinued by Fairchild Semiconductor. The datasheet is printed for reference information only. |

Rev. 131