

GX66473

4 x 64Gbps Linear Differential Driver

The GX66473 is a very low-power, high-performance, quad-channel linear driver, designed for 200G/400G optical transmitters for metro applications.

The GX66473 is a small form factor (SFF) packaged surface mount device (SMD) with differential inputs and single-ended outputs consisting of 4 x 64Gbps broadband amplifier channels, each capable of driving a linear output voltage of 4.5Vpp, suitable for multi-level modulation applications.

Features

- Data rate up to 64Gbps per channel for 200G/400G DP-mQAM applications
- > 10dB dynamic range of gain control
- 1.1 W (typical) per channel at linear 4.5 V_{pp}
- Ultra-low inter-channel cross-talk
- Small form factor SMD
- Internal high-frequency chokes to supplies
- Internally DC-blocked RF inputs and outputs
- Peak detector and reference voltage

Applications

- 200Gbps and 400Gbps advanced multi-level modulation systems
- High bandwidth CFP2-ACO form factor

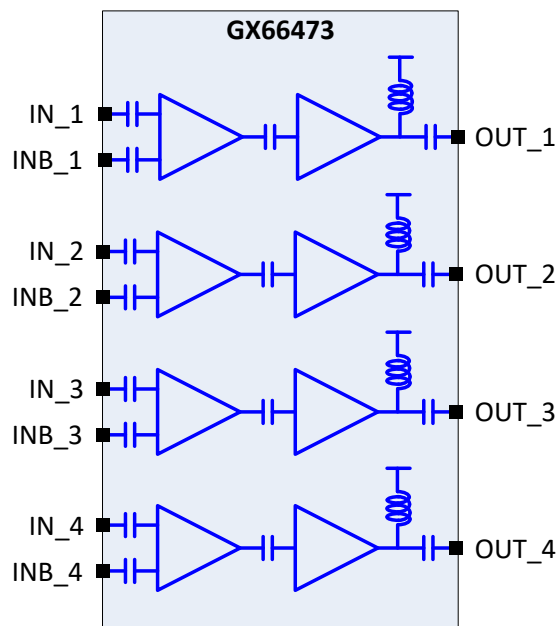

Figure 1. Block Diagram

IMPORTANT NOTICE AND DISCLAIMER

RENESAS ELECTRONICS CORPORATION AND ITS SUBSIDIARIES (“RENESAS”) PROVIDES TECHNICAL SPECIFICATIONS AND RELIABILITY DATA (INCLUDING DATASHEETS), DESIGN RESOURCES (INCLUDING REFERENCE DESIGNS), APPLICATION OR OTHER DESIGN ADVICE, WEB TOOLS, SAFETY INFORMATION, AND OTHER RESOURCES “AS IS” AND WITH ALL FAULTS, AND DISCLAIMS ALL WARRANTIES, EXPRESS OR IMPLIED, INCLUDING, WITHOUT LIMITATION, ANY IMPLIED WARRANTIES OF MERCHANTABILITY, FITNESS FOR A PARTICULAR PURPOSE, OR NON-INFRINGEMENT OF THIRD PARTY INTELLECTUAL PROPERTY RIGHTS.

These resources are intended for developers skilled in the art designing with Renesas products. You are solely responsible for (1) selecting the appropriate products for your application, (2) designing, validating, and testing your application, and (3) ensuring your application meets applicable standards, and any other safety, security, or other requirements. These resources are subject to change without notice. Renesas grants you permission to use these resources only for development of an application that uses Renesas products. Other reproduction or use of these resources is strictly prohibited. No license is granted to any other Renesas intellectual property or to any third party intellectual property. Renesas disclaims responsibility for, and you will fully indemnify Renesas and its representatives against, any claims, damages, costs, losses, or liabilities arising out of your use of these resources. Renesas' products are provided only subject to Renesas' Terms and Conditions of Sale or other applicable terms agreed to in writing. No use of any Renesas resources expands or otherwise alters any applicable warranties or warranty disclaimers for these products.

(Disclaimer Rev.1.0 Mar 2020)

Corporate Headquarters

TOYOSU FORESIA, 3-2-24 Toyosu,
Koto-ku, Tokyo 135-0061, Japan
www.renesas.com

Contact Information

For further information on a product, technology, the most up-to-date version of a document, or your nearest sales office, please visit:
www.renesas.com/contact/

Trademarks

Renesas and the Renesas logo are trademarks of Renesas Electronics Corporation. All trademarks and registered trademarks are the property of their respective owners.